

NORMAN J. COLMAN, OF MISSOURI.

THE FIRST SECRETARY OF AGRICULTURE.

BORN NEAR RICHFIELD SPRINGS, N. Y.,  
MAY 16, 1827.

DIED AT ST. LOUIS, MO.,  
NOVEMBER 4, 1911.

Lawyer, farmer, soldier, agriculturist, statesman, Mr. Colman became a leader in agricultural development in the Central West, and in 1885 was appointed Commissioner of the U. S. Department of Agriculture, becoming its first Secretary with a seat in the Cabinet, February 9, 1889, when the Department was made one of the Executive Departments. As the last of its five Commissioners and the first of its five Secretaries, Mr. Colman occupies a central position in the development of the Department's activities.

YEARBOOK  
OF THE  
UNITED STATES  
DEPARTMENT OF AGRICULTURE.

---

1912.



WASHINGTON:  
GOVERNMENT PRINTING OFFICE.  
1913.



[CHAPTER 23, Stat. at L., 1895.]

[AN ACT Providing for the public printing and binding and the distribution of public documents.]

\* \* \* \* \*

Section 73, paragraph 2:

The Annual Report of the Secretary of Agriculture shall hereafter be submitted and printed in two parts, as follows: Part One, which shall contain purely business and executive matter which it is necessary for the Secretary to submit to the President and Congress; Part Two, which shall contain such reports from the different bureaus and divisions, and such papers prepared by their special agents, accompanied by suitable illustrations, as shall, in the opinion of the Secretary, be specially suited to interest and instruct the farmers of the country, and to include a general report of the operations of the Department for their information. There shall be printed of Part One one thousand copies for the Senate, two thousand copies for the House, and three thousand copies for the Department of Agriculture; and of Part Two one hundred and ten thousand copies for the use of the Senate, three hundred and sixty thousand copies for the use of the House of Representatives, and thirty thousand copies for the use of the Department of Agriculture, the illustrations for the same to be executed under the supervision of the Public Printer, in accordance with directions of the Joint Committee on Printing, said illustrations to be subject to the approval of the Secretary of Agriculture; and the title of each of the said parts shall be such as to show that such part is complete in itself.

## P R E F A C E .

---

This volume contains 781 printed pages, comprising 259 pages for the Report of the Secretary, 282 pages for the 24 special articles, 208 pages for the Appendix, and 34 pages for the index. The volume is illustrated by 60 half-tone plates, 10 lithographic plates, and 19 text figures. The frontispiece to the volume is a portrait of Hon. Norman J. Colman, the last Commissioner and the first Secretary of Agriculture, who died during the year.

The form of the Yearbook is prescribed by law, so that there is little variation in its general form and style from year to year. The articles which were prepared by direction of the Secretary relate to subjects of general interest which have received special consideration during the year by experts in the respective bureaus, divisions, and offices of the department, and have not heretofore been published. The subjects can not be treated with exhaustive detail within the limits of this volume. In order that they may cover a wide range of information, the articles are restricted in length and are confined to the more important facts and conclusions.

The portion devoted to the Appendix comprises information that very properly comes within the scope of a yearbook. It contains, besides the Review of Weather Conditions, the names of the directors of the agricultural colleges and experiment stations, and the names and addresses of State officials in charge of agriculture in the United States, statistics relating to agriculture in aspects of production, acreage, and value of crops, of the number and value of farm animals, of prices of farm products at the farm and in the wholesale market, of foreign trade in farm and forest products, and of railroad freight rates for the transportation of principal farm products.

The statistical compilations are, collectively, a feature of the Yearbook that add to its unique character. Individually the statistical tables are original compilations and provide a great variety of information for use in books, newspapers, and magazines, for public speakers, and for investigators in many lines of endeavor.

Beginning with the earliest years for which statistics were obtained, tables are provided to exhibit the acreage, production, value, prices, exports, and imports of the corn crops of the United States, and for all or most of the items mentioned, of the crops of wheat, oats, barley, rye, buckwheat, potatoes, cotton, tobacco, flaxseed, rice, and cane and beet sugar.

For most of the countries of the world the area devoted to some of the chief crops has been ascertained for publication in the Appendix, and the list includes corn, wheat, oats, barley, rye, flaxseed, beans, and peas. The crops for which production is published for the countries of the world include the foregoing and also potatoes, cotton, tobacco, rice, hops, cane and beet sugar, coffee, and silk.

For all of the products for which the world's production is given, except oats, barley, rye, flax, beans, peas, and silk, and for tea, oil cake, and oil-cake meal, rosin, turpentine, india rubber, wood pulp, butter, cheese, and wool, there are statements of the quantities of exports and imports by the principal countries of the world.

As far as is ascertainable for all countries, there is a compilation of the number of farm animals, with designation of all cattle, dairy cows, horses, mules, sheep, swine, asses, buffaloes, camels, goats, and reindeer.

In addition to the statistical statements described, there are many that relate in other ways to the products of the farm and forest.

This is the nineteenth volume of the Yearbook issued, the total editions of which have aggregated about 9,500,000 copies. The department's allotment is distributed principally to its correspondents who render valuable voluntary service, the bulk of the edition being distributed by Senators, Representatives, and Delegates in Congress.

It is hoped that this volume may be found as interesting and helpful to all persons interested in agriculture as its predecessors.

JOS. A. ARNOLD,  
*Department Editor.*

WASHINGTON, D. C., *April 25, 1913.*

# CONTENTS.

	Page.
Report of the Secretary.....	9
Promising New Fruits. By William A. Taylor and H. P. Gould.....	261
Our Meadow Larks in Relation to Agriculture. By F. E. L. Beal.....	279
The Handling of Dressed Poultry a Thousand Miles from the Market. By M. E. Pennington.....	285
Some Results Obtained in Studying Ripening Bananas with the Respiration Calorimeter. By C. F. Langworthy and R. D. Milner.....	293
Crop Safety on Mountain Slopes. By J. Cecil Alter.....	309
Insects Injurious to the Onion Crop. By F. H. Chittenden.....	319
Condensed and Desiccated Milk. By Levi Wells.....	335
How the Produce Dealer may Improve the Quality of Poultry and Eggs. By H. C. Pierce.....	345
A Successful Method of Marketing Vegetable Products. By L. C. Corbett.....	353
The Chestnut Bark Disease. By Haven Metcalf.....	363
Some Useful Weather Proverbs. By W. J. Humphreys.....	373
Some Important Insect Enemies of Live Stock in the United States. By F. C. Bishopp.....	383
Relation of Birds to Grain Aphides. By W. L. McAtee.....	397
National Forest Timber for the Small Operator. By William B. Greeley.....	405
Truck Soils of the Atlantic Coast Region. By Jay A. Bonsteel.....	417
Seed Collection on a Large Scale. By Henry H. Farquhar.....	433
Improved Methods of Handling and Marketing Cotton. By Charles J. Brand..	443
Dairying and Its Relation to Agriculture in Semiarid Regions. By A. K. Risser.	463
Agriculture in Public High Schools. By Dick J. Crosby.....	471
The Settlement of Irrigated Lands. By Carl S. Scofield.....	483
Some New Grasses for the South. By R. A. Oakley.....	495
Raisins, Figs, and other Dried Fruits and Their Use. By C. F. Langworthy..	505
Possible Sources of Potash in the United States. By Frank K. Cameron.....	523
The Commercial Weather Map of the United States Weather Bureau. By Henry L. Heiskell.....	537
<b>Appendix:</b>	
Organization of the United States Department of Agriculture.....	541
Secretaries and Commissioners of Agriculture.....	541
Agricultural Colleges in the United States.....	542
Agricultural Experiment Stations of the United States, their locations and directors.....	544
State officials in charge of agriculture.....	545
Review of weather conditions during the year 1912.....	546
Statistics of the principal crops.....	557
Corn.....	557
Wheat.....	565
Oats.....	580
Barley.....	589
Rye.....	597
Buckwheat.....	604

## Appendix—Continued.

## Statistics of the principal crops—Continued.

	Page.
Potatoes.....	607
Hay.....	613
Clover and timothy seed.....*	617
Cotton.....	619
Tobacco.....	625
Flax.....	631
Rice.....	635
Hops.....	640
Beans and peas.....	643
Sugar.....	648
Tea.....	655
Coffee.....	657
Oil cake and oil-cake meal.....	661
Rosin.....	661
Turpentine.....	662
India rubber.....	663
Silk.....	664
Wood pulp.....	665
Farm animals and their products.....	666
Transportation.....	703
Imports and exports of agricultural products.....	712

# ILLUSTRATIONS.

## PLATES.

	Page.
Portrait of NORMAN J. COLMAN.....	Frontispiece
PLATE I. Eastman apple.....	264
II. Monocacy apple.....	264
III. Summer King apple.....	264
IV. Douglas pear.....	264
V. Chesapeake strawberry.....	272
VI. Ormond persimmon.....	272
VII. Pollock avocado.....	272
VIII. Major, Burkett, Warrick, Havens, and Owens pecans.....	272
IX. Poultry packed in a barrel with ice.....	288
X. A wagonload of live poultry coming to a western packing house.....	288
XI. Live poultry by the carload.....	288
XXII. Figs. 1 and 2.—Large feeding stations. Fig. 3.—At feeding time in the fattening station.....	288
XIII. A poultry-killing room.....	288
XIV. Fig. 1.—“String” killing and picking. Fig. 2.—“Bench” killing and picking.....	288
XV. Removing small feathers.....	288
XVI. Metal poultry-chilling racks.....	288
XVII. Grading from a hanging rack.....	288
XXVIII. Box-packed poultry ready for shipment.....	288
XIX. Dressed poultry packed in cartons.....	288
XX. Putting ice and salt into refrigerator car.....	288
XXI. Refrigerator car loaded with poultry in boxes and barrels.....	288
XXII. A view from foothills, looking across an arm of Utah Valley.....	312
XXIII. Fig. 1.—A view across the Salt Lake Valley. Fig. 2.—Maplewood cherry farm.....	312
XXIV. Normal onion plants grown in large pot to prevent infestation by thrips.....	328
XXV. Infected onion field, showing defective bulbs compared with normal bulb.....	328
XXVI. Onion leaves, showing injury by onion thrips and red spider, and uninjured leaf.....	328
XXVII. Fig. 1.—Onion and cabbage fields adjoining, each serving as a breeding place for onion thrips. Fig. 2.—Types of nozzles used in spraying for the onion thrips.....	328
XXVIII. Fig. 1.—Onions when first infested by migrating thrips in June. Fig. 2.—Onions in crates, with the tops left in piles highly infested with thrips, eggs, and adults.....	328
XXIX. Two-row field sprayer used against the onion thrips.....	328
XXX. Fig. 1.—Two-row field sprayer in action. Fig. 2.—Power sprayer in operation.....	328
XXXI. Cutworm moth.....	328
XXXII. Onion plant from Knox, Ind., showing pathological conditions found to be due to work of wire worms at roots.....	328
XXXIII. Candling eggs at the farmer's gate.....	346
XXXIV. A typical girdling “canker” of the chestnut-bark disease.....	368
XXXV. Destruction of chestnut trees by the bark disease.....	368
XXXVI. Ornamental chestnut trees dying with the bark disease.....	368
XXXVII. Small chestnut tree in pot about three months after artificial inoculation.....	368
XXXVIII and XXXIX. Insect enemies of live stock in the United States.....	392
XL. A “farmers’ saw mill” on the Weiser National Forest, Idaho.....	408
XLI. Fig. 1.—A small mill on the Boise National Forest, Idaho. Fig. 2.—A small mountain saw mill on Holy Cross National Forest, Colo.....	408
XLII. Fig. 1.—Taking out mining timbers from the Beartooth National Forest, Mont. Fig. 2.—A small National Forest saw mill in Colorado.....	408
XLIII. Characteristic location on the trucking soils of the Norfolk and Portsmouth series.....	424
XLIV. Fig. 1.—A crop of early Irish potatoes on Coxville sandy loam, Myrtle Beach, S. C. Fig. 2.—Thinning beets, Beaufort, S. C.....	424
XLV. Fig. 1.—Early Irish potatoes on Norfolk fine sandy loam, near Charleston, S. C. Fig. 2.—Winter cabbage on Norfolk fine sandy loam.....	424
XLVI. Fig. 1.—Harvesting field lettuce on Norfolk fine sandy loam near Charleston, S. C. Fig. 2.—Harvesting field of beets on Norfolk fine sandy loam, Charleston, S. C.....	424

	Page.
PLATE XLVII. Field lettuce, Castle Hayne, N. C. ....	424
XLVIII. Fig. 1.—Klondyke strawberries on Coxville fine sandy loam near Conway, S. C. Fig. 2.—Uncleared Savannah land, Norfolk fine sandy loam, in eastern North Carolina. ....	424
XLIX. Western yellow pine seed gathered on the Black Hills National Forest. ....	440
L. Two types of cone gatherers. ....	440
LI. Fig. 1.—A squirrel hoard. Fig. 2.—Government pack train on the Kaniksu National Forest. ....	440
LII. A partially unloaded wagon at the cone bins, showing construction of bins to insure ventilation. ....	440
LIII. Fig. 1.—Ordinary flat bale of cotton as it frequently appears after sampling and rough handling. Fig. 2.—Typical commercial gin plant in southern Texas. ....	456
LIV. Fig. 1.—Railroad compress at Shreveport, La. Fig. 2.—Ordinary compressed cotton bales ready for export. ....	456
LV. Fig. 1.—The round cotton bale. Fig. 2.—Gin-compressed cotton bales. ....	456
LVI. Fig. 1.—Farmers' cotton bales in dilapidated condition. Fig. 2.—Farmers' cotton bales produced by the best custom ginneries. ....	456
LVII. Home of John Christensen, New Salem, N. Dak. ....	464
LVIII. Fig. 1.—Half-blood Holstein calves from native cows. Fig. 2.—Oat hay, Limon, Colo. ....	464
LIX. Kafir corn and sorghum, Flagler, Colo., 1912. ....	464
LX. Fig. 1.—Millet, Geneva, Colo., 1912. Fig. 2.—Corn for silage, Limon, Colo., 1912. ....	464
LXI. Minnesota high-school students testing seeds and judging and grading wheat. ....	480
LXII. Fig. 1.—Fall vegetables in high-school gardens at Coin, Iowa. Fig. 2.—Coin high-school building. ....	480
LXIII. Shop and field work of high-school students. ....	480
LXIV. Farm mechanics. ....	480
LXV. Fig. 1.—First load of baled Rhodes-grass hay produced in this country. Fig. 2.—Rhodes grass, showing the characteristic habit of the runners in producing new plants at the nodes. ....	496
LXVI. Rhodes grass, showing its general habit of growth. ....	496
LXVII. Fig. 1.—The third cutting of Rhodes-grass hay. Fig. 2.—Tunis grass. ....	496
LXVIII. Fig. 1.—A field of Sudan grass seeded in 18-inch rows. Fig. 2.—Seeds of Tunis grass, Johnson grass, and Sudan grass. ....	496
LXIX. Root systems of Sudan grass and Johnson grass. ....	496
LXX. Natural hybrids of Sudan grass and hybrids. ....	496

## TEXT FIGURES.

Fig. 1. The onion thrips ( <i>Thrips tabaci</i> ).....	320
2. The spotted ladybird ( <i>Megilla maculata</i> ).....	322
3. <i>Thripoctenus russelli</i> .....	322
4. Two-row arrangement of nozzles for spraying onion thrips.....	325
5. Four-row attachment for onion sprayer.....	325
6. Seed-corn maggot ( <i>Pegomya fusciceps</i> ).....	326
7. Young onion plant, showing imported onion maggots at work in the bulb.....	327
8. Onion maggot ( <i>Pegomya cepetorum</i> ).....	328
9. Black onion fly ( <i>Tritoxa flexa</i> ).....	328
10. The wheat wireworm ( <i>Agriotes mancus</i> ).....	334
11. Larva of buffalo gnat ( <i>Simulium pecuarum</i> ).....	384
12. <i>Simulium pecuarum</i> , one of the buffalo gnats.....	384
13. The ox bot or heel fly ( <i>Hypoderma lineata</i> ).....	388
14. The screw-worm fly ( <i>Chrysomya macellaria</i> ).....	393
15. Goldfinch.....	399
16. Chipping sparrow.....	400
17. Song sparrow.....	401
18. Sketch map showing location of the trucking district.....	418
19. A typical commercial weather map.....	538

**YEARBOOK**  
OF THE  
**U. S. DEPARTMENT OF AGRICULTURE.**

---

**REPORT OF THE SECRETARY.**

**Mr. PRESIDENT:**

I respectfully present my Sixteenth Annual Report, covering the work of the Department of Agriculture for the year 1912.

**BRIEF COMMENTS.**

The most effective move toward reduced cost of living is the production of greater crops. This is attributable to the work of the Department of Agriculture, the agricultural colleges and experiment stations, and the help of the press in publishing every movement to help the farmers. Demonstration work in Southern States in the fields has been of immediate benefit. The South has increased the food supply very much in the last few years. The movement ordered by Congress to take farm demonstration into all Northern States will bring more food into our markets. Our fields can and will steadily increase their output in coming years as ways and means of growing heavier crops become better understood. The Nation forgot its farmers in the general scheme of education of past years; few philanthropists thought of them when giving for education. Congress is good to them. They are waking up and thinking for themselves.

The crop of sugar from the beet was 600,000 tons a year ago; it is 700,000 tons this year. The sugar comes from the carbon-dioxide of the atmosphere, taking no valuable plant food from the soil. The process of growing is intensive agriculture, something new to all but our gardeners, and prepares the soil for increased yields of all other crops.

One hundred and sixty-four thousand square miles have been cleared of the fever tick in the Southern States, equal to the area of three States. The farmers there are bringing in improved stock and will soon contribute materially to the meat supply.



Seven hundred acres of Egyptian and other long-staple cotton are being grown on the Colorado River in southern California, under research conditions that give good promise of eventually supplying the demand for such fibers. Thread makers of Europe are here inquiring into future supplies of long-staple cotton. The market waits for the scientist to do his work.

When the Panama Canal is open for business our bulbs and beet seed will come from the Pacific coast.

The leading specialists of the Department of Agriculture educate their assistants. The outside world wants them and pays more than the law permits being paid in the Government service.

The food and drugs act is exacting on department time; 1,459 violations were sent to the Department of Justice during the last year—25 per cent more than in the year before. Jail sentences are now being imposed.

Our farmers get only half crops on the average, or 10 tons of beets from an acre. They are learning how to farm intensively and will grow twice this tonnage in a few years, when they will not fear reduction of duties.

Our dry-land problems will be measurably solved through alfalfas from Siberia and nonsaccharine sorghums from Africa.

Congress has given us law to keep out diseased and insect-infested plants.

Farm demonstration in the fields is being organized in all the Northern States, Congress providing.

The field is the best classroom for instruction in practical agriculture.

Department study of poultry and eggs will help to get these foods to market in good condition.

The sea is the great reservoir of potash. The kelp plant gathers it. We gather the kelp and extract.

Two feet of woven wire and three barb wires keep dogs out of a sheep pasture. Dogs outnumber sheep in many States, and we have not learned to eat dogs as they do in some European countries. The reason given by most farmers why they do not keep sheep is "the dogs." Kansas had, in 1910, 175,000 sheep and 199,000 dogs, Coburn tells us.

The town does not need the retired farmer, while the farm needs his experience and his capital. A retired farmer is capital going to waste.

Taking care of the soil is the first consideration in the conservation of our resources.

Denmark buys our mill feeds and sells \$40,000,000 of dairy products to Great Britain.

Bookkeeping will soon be as common on the farm as in the factory. It is just as important for a farmer to know what it has cost to produce a given crop as for the manufacturer to know the cost of making the article he sells.

### **CROP RESULTS.**

#### **MOST PRODUCTIVE OF ALL YEARS.**

##### **EARTH'S GREATEST DIVIDEND.**

Most productive of all agricultural years in this country has been 1912. The earth has produced its greatest annual dividend. The sun and the rain and the fertility of the soil heeded not the human controversies, but kept on working in cooperation with the farmers' efforts to utilize them. The reward is a high general level of production. The man behind the plow has filled the Nation's larder, crammed the storehouses, and will send liberal supplies to foreign countries.

The prices at the farm are generally profitable, and will continue the prosperity that farmers have enjoyed in recent years. In spite of the lower total value of animals sold and slaughtered, the total crop value is so far above that of 1911, and of any preceding year, that the total production of farm wealth is the highest yet reached by half a billion dollars.

Based on the census items of wealth production on farms, the grand total for 1912 is estimated to be \$9,532,000,000. This unthinkable amount of wealth has been contributed to the Nation in one year by the soil and by the farmers' live stock. It is more than twice the value of the wealth produced on farms in 1899, according to the census, and it is about one-eighth more than the wealth produced in 1909.

During the last 16 years the farmer has steadily increased his wealth production year by year, with the exception of 1911, when the value declined from that of the preceding year. If the wealth

produced on farms in 1899 be regarded as 100, the wealth produced 16 years ago, or in 1897, is represented by 84, and the wealth produced in 1912 by 202.1. During the 16 years the farmers' wealth production increased 141 per cent.

The array of figures that expresses the farmers' contribution to national wealth production testifies to the farmers' basic importance to the Nation. During the last 16 years the wealth production on farms, according to the census items, reached the grand total of more than \$105,000,000,000. This stream of wealth has poured out of the farmers' horn of plenty, and in 16 years has equaled about three-quarters of the present national wealth.

#### CHIEF CROPS.

In the statement that follows concerning the crop quantities and values for 1912 no figures should be accepted as anticipating the final estimates of this department to be made later. Only approximations can be adopted, such as could be made by any competent person outside of this department. All values are for products at the farm unless otherwise stated, and in no item are values at the produce or commercial exchange.

#### CORN.

A cornfield half as large again as Italy, or nearly as large as either France or Germany, is the area of this country's cornfield. The largest crop of corn ever produced in this country was that of 1912. It reached the staggering amount of 3,169,000,000 bushels, or considerably more than the record crop of 1906, and much above the average crop of the preceding five years. For reasons which are perhaps economic, or perhaps due to custom, the United States raises three-quarters of the world's crop of corn. As a corn-producing country Austria-Hungary stands next to the United States, with a maximum production of over 200,000,000 bushels, and Argentina, standing third, has a maximum production of a little less than that amount.

The value, too, of the corn crop of this year is the highest on record. The most valuable previous crop was that of 1908, but the value of this year's crop much exceeded it and reaches the fabulous amount of \$1,759,000,000. Well did the poet sing, "No richer gift has Autumn poured from out her lavish horn!" The corn crop of this year is worth to the farmer 20 per cent more than the average corn crop of the previous five years.

#### HAY.

Hay has returned to its old place and is the crop that is second in value. It held this place for many years until in recent times,

when it gave place to wheat and then to cotton, but this year cotton is apparently below hay in value. It was a most productive year for grass and hay, and the harvest of hay is measured by 72,425,000 tons. No previous year has equaled this quantity; it is 16 per cent above the average crop of the preceding five years.

The value of the hay crop this year, \$861,000,000, has not been equaled. It is immensely more valuable than the crop of 1910, which had held the record. The average value of the hay crops of the preceding five years is exceeded by the value of this year's crop by 21 per cent. The importance of this crop to the farmer is better realized when it is observed that its value is greater than that of the cotton crop and nearly as great as the combined values of the wheat, tobacco, and potato crops.

#### COTTON.

It is too early to estimate the production of cotton this year, but there is a general agreement throughout the country that the crop will be the second one, considerably below the great crop of 1911 and somewhat above the next highest crop, which was raised in 1904. If the lint produced equals the general expectation, it will weigh about one-eighth more than the average crop of the preceding five years.

In value, as well as in production, the cotton crop of this year stands second. While the production of 1911 was greater, the value of that crop was not correspondingly large, and was exceeded by the much larger value of the much smaller crop of 1910. The crop of 1910 had 11,609,000 bales of 500 pounds and was worth to the producer \$788,000,000; the crop of 1911 had 15,693,000 bales and was worth only \$661,000,000. The lint crop of 1912 may be worth \$735,000,000.

Cotton often demonstrates the frequently observed fact that a crop of excessively high production may not be worth as much in the aggregate as one that is about sufficient for the requirements of consumption. It is a matter of great importance to the farmer that he should not overproduce. Not that he objects to the presence of an abundance of products for their own sake, but that he foresees unprofitable prices. Farmers, in their collective action, endeavor to produce about the quantity of a crop that they can market at profitable prices. An experience of years gives them a rough sort of judgment with regard to this quantity, but they can not foresee what the weather will do to their crops. Having made their planting and sowing plans, it may be assumed, with fairness to themselves and also to consumers, the crop suffers under unforeseen adversities, there is inadequate production, and the general conclusion is that the agriculture of the country is unable to meet national requirements. This

conclusion, however, is soon forgotten, and, as a prominent live-stock paper has recently stated, "given three years of real farm plenty and prophets of dwindling food supplies in comparison with population will take down their signs."

To the value of the cotton lint must be added the value of the seed, which in recent years has grown to a very large figure. Not so very many years ago cotton seed was a nuisance to the planter and was worse than worthless. It has now become worth more than \$100,000,000. The seed from the crop of this year is estimated to be worth about \$117,000,000, or 6.3 per cent more than the average value of the preceding five crops, but it does not equal the value of the seed of the crops of 1909, 1910, and 1911, although it exceeds all other years. Cotton lint and seed should be combined in stating the value of the cotton crop. Together they are worth about \$860,000,000, or about half the value of the corn crop and a little less than the value of the hay crop. In value as well as in production the cotton crop of this year has been exceeded by only one year, and that was by 1911 for production and by 1910 for value.

#### WHEAT.

The wheat crop has lost ground in relative importance of value in recent years. The crop of this year is estimated to be worth to the farmer \$596,000,000, an amount which was exceeded by the value of the crops of 1909 and 1908, but no other year. However, it is nearly 2 per cent more valuable than the average crop of the previous five years.

The quantity of the crop, on the other hand, makes a much more favorable comparison with the average production of the previous five years, since it is 11.2 per cent greater. The wheat production of this year amounts to 720,333,000 bushels, a quantity that was exceeded by the 748,460,000 bushels of 1901 and the 735,261,000 bushels of 1906. The crop of this year is third in size and was only 15,000,000 bushels below the next higher crop and only 28,000,000 bushels below the highest production that this country has had. This is a sort of double crop, inasmuch as it is subdivided into spring and winter crops, and had the winter crop of this year done as well as the spring crop did the total of the two might have made a new record.

#### OATS.

Fifth in order of value is the oats crop. The production this year was extraordinary. It reached an amount 46 per cent above the largest crop previously produced, that of 1909. The season was remarkably favorable to oats, especially in the greater producing States. The crop of 1912 was 1,417,172,000 bushels, or 51.5 per cent greater than the average of the preceding five years.

The price of oats has necessarily declined in consequence of such enormous production, and yet, contrary to the result that has been observed in the case of cotton, the aggregate value of the oats crop this year has not been equaled; indeed, this value is 22.2 per cent above the average of the preceding five years, and amounts to \$478,000,000. This is a value within \$118,000,000 of the worth of the wheat crop and is a little more than half of the value of the entire cotton crop.

#### POTATOES.

Sixth in order of value is the potato crop. Its amount is \$190,000,000, a low amount for this crop in recent years. The crop of three former years exceeded that of this year in value, and the average value of the crops of the five preceding years was higher by about 3 per cent.

The production of this crop, on the other hand, is higher than has heretofore been reached, and amounted to 414,289,000 bushels, or about 29 per cent above the five-year average. In consequence of the high production of this year, the price of potatoes has fallen to a low figure in some regions. This crop seems to be one of those that are worth less in the aggregate when the production is very high than they are worth when the production is low. The potato crop of 1911, it will be remembered, was deficient and large imports were brought into the country to supply the temporary deficiency, yet the short crop of 1911 was worth \$234,000,000, or \$44,000,000 more than the abundant crop of this year is worth.

#### BARLEY.

With a production of 224,619,000 bushels the barley crop of this year far exceeds the largest one heretofore produced. It is an extraordinary production for this country, and exceeds the average crop of the five preceding years by 35.7 per cent. This is a crop that has increased very much during the last 20 years, and even during the last 10 years. Perhaps, in consequence of the extremely high production, the price of barley has declined so as to make the value of the entire crop below that of the record year. This year's crop is valued at \$125,000,000, while the crop of 1911 had a value of \$139,000,000, although its production was 64,000,000 bushels less. Still, the value of this year's crop is 18.5 per cent above the five-year average.

#### TOBACCO.

The tobacco crop has not quite risen to the high level of production of most of the other crops, since it has been exceeded by the crops of two former years. The production, however, of 1912 is 959,437,000 pounds, and is 7.1 per cent above the average of the preceding five

years. The price of tobacco has risen somewhat, so that the total value of the crop is about 11 per cent above the five-year average. The value of the crop has gained more than the production. The value has not been determined, but apparently it is about \$97,000,000, an amount that has been twice exceeded.

#### FLAXSEED.

Among the smaller crops flaxseed is the most valuable one, the amount for this year being about \$39,000,000, or 32.4 per cent above the average value of the five preceding crops. This gain is partly due to extraordinary crop failure in 1910. The production of 1912 has never been equaled and is 44.1 per cent above the five-year average. Its quantity is 29,755,000 bushels.

#### RYE.

Rye is one of the crops that remain nearly stationary in production and vary little from year to year. The crop of 1912 contained 35,422,000 bushels and is the largest that has been produced by a small margin. It is 10 per cent above the five-year average. The total value of this crop, \$24,000,000, has not gained in equal degree, since it increased only 2.3 per cent over the five-year average; and while the production was highest, the total value was exceeded by that of two other crops, those of 1910 and 1911.

#### RICE.

Although the production of the rice crop can not now be announced, the indications are that it has been exceeded by the production of only one year, and that it is about 8 to 10 per cent above the average production. This crop was damaged by the extraordinary freshet of the Mississippi River last spring, or else the production would, perhaps, have been a record one. The value of this crop is unusually high and is far from being equaled by that of the crop of any former year. It may amount to upward of \$20,000,000.

#### BUCKWHEAT.

A decided tendency to increase in production has been manifested in this crop in recent years. The production of 1912 is the largest since 1868 and is 19.3 per cent above the five-year average. The production is small, as crops go in this country, and amounted to only 19,124,000 bushels in 1912, but the demand for this cereal is increasing and there are practically no exports. The value of the crop of this year is over \$12,000,000 and exceeds the five-year average by about 11 per cent. It has been exceeded since 1869 only in one year.

## HOPS.

Extraordinary conditions of the world's hop market in 1911 on account of deficient European production have not been repeated this year, and consequently this crop finds a much more normal situation. The production of 1912 is estimated to have been 44,500,000 pounds, or about 1 per cent below the 5-year average, but the total value of the crop is 38.3 per cent above the average and amounts to about \$11,000,000.

## ALL CEREALS.

All of the cereals except wheat and rice produced their largest crops in 1912, and consequently the total production of this class of crops is far above the average. The gain is 25.6 per cent above the 5-year average. The total production of the seven cereals amounts to 5,609,807,000 bushels, a bulk of food so large as to be entirely beyond understanding. The largest total of any preceding year was 4,958,559,000 bushels in 1910.

The combined value of this great mass of products is a little over \$3,000,000,000, and is 15.8 per cent above the average of the previous five years. In no previous year has the value of the cereals exceeded \$2,760,000,000, the figures for 1908.

## SUGAR.

Sugar is a product of manufacture from the farmers' sugar beets and sugar cane. The farm products can best be treated from the point of view of the manufactured sugar and the by-products.

Beet sugar is a comparatively recent product in this country. The raising of sugar beets for sugar making can hardly be regarded as being an established industry 16 years ago. Beginnings had been made, but the success of the industry was not assured. Under the encouragement of the law, this department and other agencies promoted the growth of this industry, and the industry grew year by year and it became more firmly established.

The latest fruition of all these efforts appears in the magnificent testimonial of the production of 1912. The production of this sugar in 1899, as ascertained by the census, was 81,729 short tons. It increased to 218,406 tons in 1902, to 312,921 tons in 1905, to 501,682 tons, according to the census, in 1909, and to 599,500 tons in 1911. The production of 1912 amounts to about 700,000 short tons, or a gain of about 100,000 tons over the preceding year.

The beet-sugar production of 1912 is about one-fifth of the national consumption of sugar and illustrates what can be done under the protection of the law and in consequence of practical and well-directed efforts.



Beets yield from 10 to 13 tons per acre, and the grower receives from \$50 to \$70 or more per acre for a crop that leaves his land in better condition after harvest than before. Moreover, the market for the beets is found before the crop is planted. Beet factories furnish in pulp a serviceable stock feed. The growth of this industry and the plans for its increase indicate that beet raising for sugar purposes is much desired by farmers for profit and cultural benefit to the land.

If the by-products of the beet-sugar manufacture are combined with the factory value of the sugar, the total value of the products of the beet-sugar industry in 1912 is found to be about \$67,000,000.

The cane-sugar industry fared badly this year on account of the Mississippi River flood. The production of sugar is the lowest since 1899, and the value of the products of the industry, including molasses and sirup, is only about \$34,000,000.

The sorghum sirup and maple sugar and sirup industries of the farm produce a value of about \$15,000,000 a year, and the total of this amount and of the value of the products of the beet-sugar and cane-sugar industries is about \$117,000,000 for 1912. This is a reduction of about \$20,000,000 below the combined values of these industries for 1911, but the loss of the cane-sugar industry in 1912 as compared with 1911 is much more than this amount, so that had it not been for the Mississippi flood the value of the products of these industries would have been higher than in 1911, and the amount for that year was the highest reached.

#### SUMMARY OF COMPARISONS.

The year 1912 was a record breaking one for crop production and crop values. Only two crops had been exceeded twice in production, and these are wheat and tobacco. The high production of buckwheat half a century ago is ignored. Only two crops had been exceeded once in production, and these are cotton and rice. All of the other crops stand at high-water mark—all of the cereals but wheat and rice, the great hay crop, potatoes, flaxseed, and beet sugar.

With respect to value, the only crops that have been exceeded three times are potatoes and cotton seed; the crops exceeded twice in value are wheat, cotton seed, tobacco, and rye; and the crops that have been exceeded once in value are cotton lint, beet sugar, and buckwheat (since 1869). All other crops reached their highest value in 1912, and these included all of the cereals except wheat and rye, the prominent hay crop, flaxseed, and beet-sugar by-products.

#### INCREASE OVER 1911.

The year 1911 was one of low production, 1912 of high production. The contrast clearly appears when expressed in percentages of in-

creased production. The corn crop of 1912 increased 25.2 per cent above that of 1911; the wheat crop, 15.9 per cent; the oats crop, 53.7 per cent; barley, 40.2 per cent. All of the cereals increased, and the average for them is 30.2 per cent, which expresses the gain of 1912 over 1911 in quantity of production for the cereals. The gain in value was much less, or only 10.8 per cent. Among the gains of other crops in quantity appear 52.7 per cent for hay, 41.5 per cent for potatoes, 53.6 per cent for flaxseed, 16.8 per cent for beet sugar. The only crops for which value increased at least in the degree of increase of production, are rice, sugar beets, and tobacco, while in the case of cotton the production decreased and the value increased.

#### LIVE-STOCK PRODUCTS.

##### DAIRY AND POULTRY PRODUCTS.

The dairy cow is one of the principal producers of wealth on the farm, although not prominent in public notice. The farm value of the dairy products of 1912 is estimated at about \$830,000,000, an amount which exceeds the value of the cotton lint and is nearly equal to the combined value of lint and seed. The products of the dairy cow are worth nearly as much as the value of the hay crop and are nearly twice the value of the oats crop. The wheat crop is worth only three-quarters as much.

Poultry is another industry of great wealth production on the farm. Here is an illustration of how large an aggregate of an immense number of little things can become. An egg may be worth only a cent and three-quarters, and yet 1,700,000,000 dozen eggs are worth \$350,000,000, and these are the estimates for 1912.

If to the value mentioned is added the value of the fowls raised, the products of the poultry industry on farms amounts to about \$570,000,000. This is nearly equal to the value of the wheat crop and exceeds the value of the oats crop. It is more than three-quarters of the value of the cotton lint produced this year. The value of poultry products in 1912 has been exceeded in two former years.

Wool production has apparently been exceeded in two former years, yet in 1912 it amounted to 318,548,000 pounds. This wool had a farm value of about \$55,500,000, or about 6 per cent below the average value of the wool clip of the five preceding years.

The animals sold from the farm and the animals slaughtered on it together numbered about 111,000,000 for 1912, and the farm value of these animals is estimated to be \$1,930,000,000. This is the highest value of animals sold and slaughtered since about 1900, except in 1909 and 1911.

##### VALUE OF ALL ANIMAL PRODUCTS.

The total value of the animal products of the farm in 1912 is estimated to be about \$3,395,000,000. This is a larger value than that of

1911, but is about \$150,000,000 below the estimate for 1910, which is the only year that exceeds 1912 in value of animal products produced on the farm.

While the animal products are about one-third of the value of the wealth production of the farm in 1912, the crops are about two-thirds. Their value in 1912 is \$6,137,000,000, an amount which is vastly above the high-water mark of total crop value in 1911.

Such are some of the details with which the grand aggregate of \$9,532,000,000 has been built to represent the farm value of the wealth created on the farms of this country in 1912. This industry of agriculture has grown to be so great that in discussing such features as these hundreds of millions and billions are common coins of expression.

### PRICES OF FARM PRODUCTS.

#### COMPARISON WITH RECENT YEARS.

##### CHANGES SINCE 1911.

Farm prices at which the crops of 1912 are valued declined from the prices of 1911 in the cases of some important products. The barley crop has declined about 36 per cent in price per bushel; the corn crop about 10 per cent; the oats crop about 25 per cent; the rye crop about 17 per cent; and the wheat crop about  $5\frac{1}{2}$  per cent. The large crop of hay caused a decline of about 19 per cent in price per ton, and the extraordinarily large potato crop suffers a decline of about 43 per cent from the price of 1911. For a reason already stated, there is cause for the decline of about 42 per cent in the price of the hop crop per pound. The flaxseed crop has declined about 27 per cent in price, beet-sugar and cane-sugar crops about 22 per cent.

The price of the cotton crop of 1912 has gained about 25 per cent over that of the crop of 1911, and the price of the seed has gained nearly 5 per cent. The gain of price for the rice crop is nearly 13 per cent, for the tobacco crop about  $7\frac{1}{2}$  per cent, and for the wool clip nearly 7 per cent.

Among the dairy products the price of the year's product of butter has increased about 11 per cent over that of 1911, and the price of milk nearly 5 per cent. A decline of nearly 1 per cent is found in the price of the year's production of poultry, and a gain of nearly 16 per cent in the price of the year's production of eggs.

##### COMPARISON WITH AVERAGE OF FIVE YEARS.

When the price adopted for the crop of 1912 is compared with the mean of the preceding five years, decreases are noticed all along the line. The decrease for corn is 1.4 per cent; for wheat, 9.1 per cent;

for oats, 20.4 per cent; for barley, 13.7 per cent. For cottonseed the decline is 11.3 per cent, and for cotton lint 1.8 per cent; flaxseed, 15.1 per cent; potatoes, 29.1 per cent; wool, 9.8 per cent.

On the other hand, increases of crop prices of 1912 compared with the preceding five years are found in some instances. For rough rice the increase is about 14 per cent; for hay, 2.1 per cent; for tobacco, 2 per cent; for hops, 26.3 per cent; for eggs, 8.5 per cent.

#### PRESENT RESTORATION OF FORMER PRICE LEVELS.

Prices of farm products for December 1 have been collected by the Bureau of Statistics for many years. If mean prices are computed for decades, a series of price levels can be established and the trend of prices can be better observed. In the case of wheat, for instance, the mean price, December 1, for the United States at the farm was 115.5 cents from 1866 to 1870; it was 99.5 cents from 1871 to 1880; 82.2 cents in the next decade; and 63.2 cents in the decade of lowest prices, 1891 to 1900; afterwards the increase was to 79.6 cents in the decade of 1901 to 1910; and the farm price for 1912 is nearly 83 cents, or about at the level of the decade 1881 to 1890 and considerably below the level of the preceding groups of years back to 1866.

A similar treatment of cotton prices shows that the mean price of cotton in 1868 and 1869 was 14.3 cents; in the following decade it was 12.1 cents, after which it declined, until in the decade of extremely low prices, 1891 to 1900, the price is only 6.9 cents. In the following decade cotton rose to 10.8 cents; and in 1912 it is worth at the farm about 11 cents.

In the case of corn there was a decline on the whole from 52.1 cents as the mean of 1866 to 1870 to 33 cents for 1891 to 1900, followed by the mean price of 48.8 cents in the decade 1901 to 1910 and the price of about 55.5 cents for 1912.

The decline of mean prices of oats was from 39.7 cents in 1866 to 1870 to 26.1 cents in 1891 to 1900, with a recovery to 36.3 cents in 1901 to 1910, and the present price is about 33.7 cents, or substantially a restoration of the price level of the two decades extending from 1871 to 1890.

The price record for potatoes discloses the extremely low position of the price of this year's crop. The mean price for 1866 to 1870 was 56.1 cents, from which there was a decline on the whole to 44.8 cents from 1891 to 1900. The next decade had a price of 58.6 cents, and the price for 1912 is about 45.8 cents, or close to the level of the lowest price period of many years, which was from 1891 to 1900.

The foregoing extracts from price records of the Bureau of Statistics are indicative of the general downward movement of the prices of farm products from the Civil War until it was arrested in about the middle of the decade extending from 1891 to 1900. The subse-

quent elevation of prices has sometimes carried them to about the level of the earlier years under review, and sometimes higher, but it may be noticed that if comparison is made between present prices and the extremely and abnormally low prices of the nineties the present period of high prices is made by force of the comparison to occupy a relatively higher place than it does if comparison is made with the higher-price periods preceding.

## FOREIGN TRADE IN AGRICULTURAL PRODUCTS.

### ANALYSIS OF EXPORTS.

#### HIGH VALUE OF NATIONAL SURPLUS.

Over a billion dollars is, for the fourth time, the value of the exports of farm products. It is sufficient to pay the expenses of the National Government. As long ago as 1878 the value of agricultural exports reached half a billion dollars; by 1892 the amount had touched \$800,000,000; and by 1901 it had grown to \$950,000,000. The billion-dollar mark was reached in 1907, when the value of agricultural exports amounted to \$1,054,000,000. That amount has not since been equaled, but the exports of 1908 and 1911 exceeded a billion dollars in value, and in 1912 the amount fell short of the record exports by only \$4,000,000.

#### RISING QUANTITY OF EXPORTS.

The high value is not entirely due to high prices. The trend of the quantity of the exports of particular commodities can best be understood by using index numbers. Let the quantities of the average yearly exports of the 10 years 1900 to 1909 be represented by 100 and convert the quantities of the exports of other groups of years and of individual years into terms related to that basis. It will then appear that the exports of oleo oil have increased year by year after the period of 1900 to 1909 to the relative amount of 112.3 in 1912. This commodity was exported this year to the value of \$13,000,000.

Lard compounds also have increased above the average of the period 1900 to 1909, the relative number for 1912 being 114.8. The exports of this commodity are this year as high as \$5,000,000. Various animal oils, not specifically described, have increased in exports during the last three years. Another commodity that is increasing in exports is eggs, which have arisen to the relative number 359.8 in comparison with 100 as representing the 10 years 1900 to 1909. In 1912 the value of these exports amounted to \$3,400,000. The exports of mutton amount to only a few hundred thousand

dollars in value, but they are increasing, and the relative number for 1912 is 283.1 in comparison with 1900 to 1909.

The exports of cured pork hams declined in 1910 and 1911 to about three-quarters of the average from 1900 to 1909, but in 1912 the exports were very nearly restored to the former amount. Lard is another commodity that has been climbing back to former importance as an exported commodity, and the quantity exported in 1912 is indicated by 88.8. If the exports of pork and of all of its products are consolidated, it will appear that they are rapidly returning to the average exports of 1900 and 1909.

Cotton is the great mainstay of the export trade. Marked increase in exports is conspicuous. Compared with the average exports of 1900 to 1909 represented by 100, the exports of 1890 to 1899 were 79.7; the exports of 1910 were 85.7; in 1911 they were 107.8; and in 1912 the relative number is 147.9.

Apples are supporting an increased export trade, which now amounts to about \$10,000,000. The export trade in dried apples is steadily increasing, and in comparison with the average of 1900 to 1909, the exports of 1912 are represented by 159. For fresh apples the exports of 1912 are represented by 124.1. Prunes are a fruit that has reversed the tide of international trade. Its exports now amount to several million dollars a year, and are increasing. During the last three years the exports of this fruit were nearly double the average of the period 1900 to 1909. Raisins have done better yet, and now amount to about four times the average exports of the period mentioned. Their value is more than a million dollars. Glucose and grape sugar, with exports amounting to several million dollars a year, are contributing to the foreign trade annual quantities above the average of the 10-year period mentioned.

To the list of commodities whose exports are increasing and are above the average of the 10 years, 1900 to 1909, or very close to that average, may be added hops, corn-oil cake, cotton-seed oil cake and oil-cake meal, flaxseed oil cake and oil-cake meal, cotton-seed oil, linseed oil, rice, cotton seed, tobacco; and the four vegetables, beans, pease, onions, and potatoes.

The foregoing would be quite a respectable list even though cotton were omitted. Beef and its products have gone into a sorry decline in the export trade, but wheat flour still maintains a high relative showing, as is indicated by 71.2 in comparison with the annual average of the 10 years, 1900 to 1909, and has steadily increased in exports during the last three years. The exports of wheat, including flour converted to wheat, amounted to 80,000,000 bushels in 1912.

The general fact, however, is that the packing-house products have declined in value of exports since 1906, when they reached their highest value, \$208,000,000, and have declined still more in quantity

because of the increasing prices, yet the value of packing-house exports has increased since 1910 and reached the amount of \$164,000,000 in 1912. So with grain and grain products, the quantity in the aggregate is diminishing as well as the value, and the high export values of five and six years ago have not since been equaled. In 1912 the export group known as grain and grain products had a value of \$123,000,000.

#### IMPORTS.

Agricultural imports are steadily increasing in value, subject to some fluctuations. They reached their highest value in 1912, when they amounted to \$784,000,000. This was an increase of about \$100,000,000 over 1911 and 1910, the years of highest import values preceding 1912. Notable increases are found in the imports of coffee, sugar and molasses, tobacco, wool, and packing-house products, in which hides and skins are very prominent.

#### LARGE BALANCE OF TRADE MAINTAINED.

It is apparent that since 1908 the balance in the foreign trade in agricultural products has not kept up to its former figure, but, as has already been said, this is not because of diminished export values, but is due to a greater increase of imports than exports. Notwithstanding this, the balance in favor of exports of farm products was as high as \$278,000,000 in 1912, and this was higher than the amount for 1910 and also for 1909.

At no time before 1912 have farm products been hard pushed, nor, indeed, closely approached, by products other than agricultural ones in contribution to the balance of trade in favor of all exports. It was not until 1898 that products other than agricultural had a balance in favor of exports, but twice since that time—in 1903 and 1910—the balance was in favor of exports. The balance in favor of the exports of these commodities was only \$5,000,000 below the agricultural balance in 1912.

#### FOREST PRODUCTS.

Forest products were exported in 1912 to the value of \$108,000,000, and this was greater than the amount for any preceding year. This is partly due to high prices, yet there were increases in the quantities of the exports of boards, shooks, rosin, and turpentine.

The imports, as well as the exports, of forest products exhibited a marked tendency to increase in value in recent years, and during these years the imports have very much exceeded the exports in value. In 1912 the imports of forest products were valued at \$173,000,000, or \$58,000,000 more than the foreign and domestic exports.

**AGRICULTURAL CREDIT.****SURVEY OF LOCAL CONDITIONS.****INVESTIGATION IN RURAL COUNTIES.**

Agricultural credit is a subject that is attracting much attention and exciting a great deal of discussion. The information with regard to what has been accomplished in cooperative credit and in the service of great mortgage banks under governmental supervision must necessarily be derived almost entirely from foreign countries. In addition to this, little is known in regard to local conditions in all parts of this country pertaining to agricultural credit. In view of the possibility of legislation concerning the subject, and more certainly to provide information useful in discussion, the effort was made early in the autumn to collect data of a descriptive sort.

A schedule of questions was sent to 9,000 persons in all of the rural counties of the United States. There were about 3,000 country bankers, about the same number of prominent farmers, and also about the same number of country merchants and men of other occupations taken from the list in use by the Bureau of Statistics to collect monthly reports of the prices of farm commodities. It thus appears that the whole country was thoroughly covered by the schedule. The nature of the questions will appear upon examining the tenor of the answers.

Three classes of correspondents were chosen in order that if any class bias appeared it would be recognized and allowances made for exaggeration or deficiency of statement. It was hardly discoverable that class bias entered considerably into the answers given. Where differences appeared among the classes of correspondents they were probably quite as much due to differences of thoroughness of information as to bias, and perhaps differences in point of view influenced the answers. At any rate the three classes of correspondents reported remarkably well and intelligently, and, no doubt, with faithful and sincere desire to contribute to a truthful description of local rural conditions bearing upon credit.

The questions were so worded as to call for answers in numerical form in order that they might be consolidated and treated arithmetically. A set of tabulations was given to each class of correspondents, and also the three classes were combined after it was observed that the differences were not usually too great to be harmonized. Probably, on the whole, the combination of the returns from the three classes of correspondents into one set of results is often nearer the fact than is indicated by any one of the three classes. However that may be, the chief results of this investigation are herewith presented with the hope that they may be of service.



## ABLE TO GIVE GOOD SECURITY.

The first effort of the inquiry was to ascertain the fraction of the farmers owning their land who are able to give good security or indorsed note for a loan. In the opinion of the correspondents, 77 per cent of the farm owners may be so regarded, and the corresponding percentage for tenants is 46; that is to say, about three-quarters of the farmers owning their land and nearly one-half of the tenants are able to give good security or indorsed note for a loan. The farm owners and tenants unable to do this were then dropped from further consideration.

## DEFICIENT SUPPLY.

It was next attempted to ascertain what percentage of the farmers owning their land and able to give good security or indorsed note is unable to obtain needed short-time or accommodation loans and advances because of insufficient opportunities to borrow. It appears that 48 per cent of the correspondents reported that farm owners were able to obtain such loans. The other correspondents reported that 36 per cent of the farm owners in their communities were unable to do so.

A similar question pertaining to long-time loans brought reports from 47 per cent of the correspondents that farm owners were able to obtain such loans. The remaining correspondents reported that 40 per cent of the farm owners were unable to do so. The corresponding percentages for tenants are nearly the same. It is easier to obtain short-time loans than long-time ones.

No attempt was made in the schedule to define long time and short time. This was purposely avoided in order that the correspondents might make their answers correspond to the local variations from the general fact. This general fact was that short-time loans were for periods less than one year.

## CONSERVATIVE AND PROFITABLE USES.

Correspondents were requested to state what percentage, in their opinion, of the farmers owning their land and able to give good security or indorsed note would use borrowed money beyond the amount, if any, now owed by them, conservatively and profitably. Many of the correspondents answered this question in such a way as to indicate that they did not understand it; but of the answers indicating a correct understanding, 26 per cent reported that no farm owners would so use borrowed money, and the remaining correspondents who answered this question reported that 32 per cent of the farm owners would use borrowed money conservatively and

profitably. Almost exactly the same percentages are indicated for tenants able to give good security or indorsed note.

#### CROP LIENS.

It is with much interest that the answers concerning crop liens have been aggregated. One question asked what percentage of the farmers owning their land, who raise cotton, place a lien on the growing crop to secure advances or supplies; and this question was followed by a similar one as for 10 years ago. In the combined answers of the three classes of correspondents, 7 per cent reported that no farm owners placed liens on the cotton crop; the remaining correspondents reported that 42 per cent of the farm owners did so, and that 52 per cent of them did so 10 years ago. The decline in the percentage therefore is 10 absolutely, or about 20 per cent relatively.

Similar questions were asked concerning tenants; and of the answers, 2 per cent stated that no tenants placed liens on the cotton crop, while the remaining answers showed that 74 per cent of the tenants now place a lien on the cotton crop to secure advances or supplies, and that 77 per cent of them did so 10 years ago. The decrease is hardly perceptible.

Pursuing the subject of crop liens, 29 per cent of the reporting correspondents stated that no farmers owning their land, who raised crops other than cotton, placed liens on such crops, and the rest of the correspondents reported that 24 per cent of the farmers did so. A similar question applied to tenants and brought answers from 17 per cent of the correspondents that farm tenants did not place liens on crops other than cotton, and the rest of the correspondents reported that 40 per cent of the tenants did so.

Information of similar sort was obtained concerning personal-property mortgages. Seventeen per cent of the reporting correspondents stated that no farm owners placed liens on their live stock, farm machinery, or other personal property of the farm; and the rest of the correspondents reported that 25 per cent of them did so. The corresponding percentages for tenants are that in 7 per cent of the communities no personal-property liens were given by tenants, and that in the other communities from which reports were received 43 per cent of the tenants did so.

#### WAREHOUSE RECEIPTS.

In communities where elevators and other warehouses are employed for storing grain, tobacco, cotton, and other products, warehouse receipts may be pledged as security for loans. It was sought to discover the extent of this practice, and 63 per cent of the correspondents reported that it did not exist, and the remaining correspondents reported that 26 per cent of the farmers holding warehouse receipts used them for the purpose of getting credit.

## SOURCES OF CREDIT.

A short analysis of the sources of agricultural credit was attempted and with considerable success. There are often various sources of credit in the same community, and it was hoped that the correspondents would be able to determine the relative importance of each.

It appears that of the principal sources of agricultural loans and advancements (not including purchase money) local banks supply 57 per cent of the total agricultural credit in communities where banks exist; neighbors supply 16 per cent in communities where they contribute anything to the supply of credit; individual lenders in near-by cities and towns supply 12 per cent in communities in which any supply of credit is derived from them; loan agents for outside capital supply 16 per cent in communities where such loan agencies exist; local general stores supply 25 per cent in communities where they contribute anything to the supply of credit; and unclassified sources of credit supply 13 per cent in the communities where these unmentioned sources of supply exist.

Local banks supply more than half of the agricultural credit, general stores supply one-quarter, and both supply more than three-quarters. The supply from neighbors is about one-seventh. The credit that is supplied from a distance, or what may be regarded as the supply from outside sources, is about one-seventh of the total supplied; and consequently it appears that about six-sevenths of the supply is derived from strictly local and near-by sources.

These conclusions apply to the communities in which these sources of credit are found. They are not found in all communities. It was reported by correspondents that in 1 per cent of the communities there was no supply of credit by banks; in 11 per cent of the communities no supply by neighbors; in 39 per cent of the communities no supply by individual lenders in near-by cities and towns; in 51 per cent of the communities no supply by loan agents for outside capital; in 47 per cent of the communities no supply by local general stores; and in 93 per cent of the communities no supply from other sources.

## RANGE OF AMOUNTS OF LOANS.

An effort was made to ascertain the range of the bulk of the individual amounts of loans and advances made to farmers owning their land, but not including purchase money. In the opinion of the correspondents, the range is, on the average of answers, from \$274 to \$1,767; and a similar question concerning tenants indicates a range of \$107 to \$473.

## STORE CREDIT.

There is one source of credit in rural regions in this country that is very prevalent, and yet it is rarely mentioned in discussions of

rural credit. This is the running accounts at the stores where the farm owners and tenants buy groceries and other goods without giving security. Correspondents were requested to report with regard to this, and their answers indicate that 59 per cent of the farmers owning their land have running accounts with local merchants and that 53 per cent of the tenants have such accounts in communities where this form of credit exists.

In 1 per cent of the communities it was reported that farm owners did not obtain store credit, and in 2 per cent of them that tenants did not do so. Country merchants sell goods on trust to more than one-half of the farm owners and farm tenants in their communities, and this without security.

#### RATES OF INTEREST.

Substantially no statistics of rates of interest paid by farmers have been collected in this country since the census of 1890; and consequently it was especially desirable that the correspondents be requested to contribute information in this investigation and report with regard to the subject. Six questions were framed, and these were answered with undoubted understanding as to the meaning of the questions. The results are of much interest.

The questions were expressed in dual form, in such a way as to call for an answer for agricultural loans and also for loans on town and city real estate, the circumstances of the loans being otherwise substantially the same.

The interest rates on the bulk of the purchase money throughout the United States range from 6 to 8 per cent in the case of farms; and also from 6 to 8 per cent in case of town and city real estate. Upon taking account of the differences in rates of interest as between farm and town property, it is discovered that in the case of purchase-money loans 10 per cent of the responses state that the rates are higher for farms than for town and city real estate; 33 per cent report that the rates are lower for farms than for town and city real estate; and 57 per cent report that there is no difference in rates of interest on purchase-money loans between the two classes.

A similar question was asked with regard to short-time loans, with the result that 11 per cent of the answering correspondents reported a higher rate for farms than for town and city real estate, 21 per cent reported a lower rate for farms, and 68 per cent reported no difference.

The same question for long-time loans induced 8 per cent of the responses to report that the rates of interest on farm loans were higher than for those on town and city real estate, 33 per cent to report that the rates were lower on farms, and 59 per cent to report no difference between the two classes of real estate.

## COSTS OF BORROWING.

Rates of interest alone do not determine the cost of borrowing. There are commissions, bonuses, and various costs and expenses that are borne by the borrower, and these, if added to the rate of interest, often considerably increase it. It was reported by 22 per cent of the answering correspondents that no commissions were paid in their communities; those who stated that commissions were paid disagreed very considerably. The country banker stated that the rate of commission, when paid, was 2 per cent. The country merchant and persons of other occupations constituting another class of correspondents reported 4 per cent, and the farmers reported 5 per cent. These differences seem hardly capable of reconciling. The terms for which mortgages are made usually range from three to five years, and consequently a commission of from 2 to 5 per cent adds appreciably to the annual rate of interest.

The correspondents were requested to report costs of abstracts, if paid by the borrower, and 94 per cent of the responses reported that the borrower did not pay for an abstract. It appears from the answers by correspondents that in cases where the borrower paid for an abstract of title, or for searching the records, the average cost was \$11.40, and in cases where the borrower paid the conveyancer for drawing the papers the average cost was \$4.70. Sometimes, too, the borrower was required to pay the registration fee, and when he did so the average cost was \$1.50.

## COOPERATIVE ASSOCIATIONS.

Finally, it was requested of correspondents to state what percentage, in their opinion, of the farmers known by them and to them would be willing to form an association to receive their own deposits for loaning to themselves, and also to borrow from the outside, on the combined security of the property of all members, money to loan to themselves.

Of the correspondents, 32 per cent reported that there were no farmers who would be willing to form such an association, but the remainder of the correspondents reported that about 40 per cent of the farmers stood ready to organize such cooperative associations.

The foregoing is a brief and highly condensed statement of the chief results of this investigation of local conditions relating to agricultural credit. Numerous variations from the general facts appear in the nine geographical divisions of the States, and still more so in the different States themselves.

**WORK OF THE DEPARTMENT IN 1912.****PERSONNEL.**

The number of officers and employees on the rolls of the department July 1, 1912, is 1,154 greater than one year ago, and 11,414 more than on July 1, 1897, the first report under my administration. The employees located in Washington number 2,815, while 11,043 are employed elsewhere. There are now 371 more employees of the department in Washington than the entire enrollment 15 years ago, and the number located outside of Washington is 371 less than the total increase, indicating how largely the department's work has changed from office and laboratory work to field and forest investigations.

During the year 45,932 changes of every description were made, including the appointment of 32,975 temporary employments for periods of six months or less, in the forests and fields and on stations in the various States outside of Washington, D. C. The number of persons receiving probationary appointments in the classified service (equivalent to absolute appointment if the appointee is retained in the department after the probationary period) was 1,361. Eighty-four persons were reinstated and 52 were transferred from other departments, 666 resigned, 33 died in the service, and 50 were removed from the service on account of misconduct.

On July 1, 1912, there were 3,938 officers and employees on the statutory roll, comprising positions specifically appropriated for by Congress (a decrease of 70 during the year), and 9,920 were paid from lump-sum appropriations (an increase of 1,284 over last year), making a total enrollment of 13,858, not including temporary "field" employees.

There were 2,257 promotions in salary in all branches of the department and 143 reductions in salary. In the city of Washington 1,972 males and 843 females are employed, and outside of Washington the males number 10,411 and the females 632, the total female employees being 11.9 per cent of the male.

**INSECTICIDE AND FUNGICIDE BOARD.**

By the provisions of an act approved April 26, 1910, and known as the insecticide act of 1910, this department was made responsible for the collection and examination of samples of articles coming within the meaning of the act, and to report violations of the act to the Department of Justice.

To assist me in this work a board was created consisting of four scientists from the Bureaus of Animal Industry, Chemistry, Entomology, and Plant Industry.

As the first appropriation for enforcing the insecticide act became available on March 4, 1911, the remainder of that fiscal year was occupied with the organization of a working force and the initiation of work.

During the fiscal year 1912, 650 samples were collected, representing 330 different articles, produced by 212 different manufacturers; 246 of these cases have been disposed of, 182 being placed in permanent abeyance, while 64 have been transmitted to the Attorney General for prosecution; 7 of the latter cases have been passed upon by the courts with results favorable to the Government's contentions.

More than 200 hearings have been held during the year, 17 of which were conducted by the Insecticide and Fungicide Board and the others under the supervision of the board. Six special hearings were held by the board to discuss with manufacturers questions relating to the construction and enforcement of the insecticide act.

Six insecticide decisions were issued during the year.

#### OFFICE OF THE SOLICITOR.

The volume of work of the Solicitor's office has been greater than during any previous year, because of the normal growth of the department's legal business, the passage of the Weeks Forestry Act, relating to the purchase of lands for National Forest reservations, and the claims arising on the deficiency act appropriating funds for the relief of those rendering service during the forest fires of 1910.

Additional work has been called for in preparation of briefs and in correspondence connected with the increased number of violations detected by the vigilance of the department's inspectors under the National Forest law, the food and drugs act, the meat-inspection law, the 28-hour law, the animal quarantine laws, and the insecticide and Lacey acts.

Frequent advice has been given the several bureaus, divisions, and offices on questions of law relating to the discharge of the varied duties intrusted to them, and the Solicitor has attended, as representative of the department, all the hearings conducted by the House Committee on Expenditures in the Department of Agriculture.

#### FOOD AND DRUGS ACT.

The provisions of the food and drugs act have been vigorously enforced during the year, and 1,459 violations were reported to the Department of Justice, an increase of more than 25 per cent over the number reported last year. Of these, 991 were criminal cases and 468 were recommendations for seizure of adulterated or mis-branded foods and drugs.

The first jail sentences for violation of this act were imposed during the year, and there was a tendency on the part of the courts to im-

pose larger fines for first offenses. Fines amounting to \$14,000 were imposed in criminal cases, and the costs were generally assessed against the defendants. In the seizure cases, decrees of condemnation and forfeiture were entered against 294 shipments of adulterated and misbranded goods. One hundred and three shipments consisting of filthy, decomposed, or putrid substances, or containing added poisonous or deleterious ingredients, which might render them injurious to health, were destroyed, and in several instances such cases have been reported for criminal prosecution. Six hundred and fifty-five Notices of Judgment of terminated cases have been published, and over 300 are in course of preparation.

#### WORK FOR THE FOREST SERVICE.

During the fiscal year 1912 the Solicitor rendered 93 formal and 1,148 informal written opinions to the Forest Service on the legal phases of questions arising in connection with the administration of the National Forests. One thousand two hundred and fifty contracts, leases, bonds, and right-of-way stipulations were prepared and examined for sufficiency of execution. One thousand five hundred and sixty-eight cases involving contested claims to lands within the National Forests were handled during the year. These cases involved upward of 400,000 acres of land, supporting many million feet of valuable merchantable timber. Final action was taken by the Secretary of the Interior or the Commissioner of the General Land Office in 622 of the above cases, of which 462 were decided favorably to the United States. The office filed 241 briefs in contested-claims cases during the year and prosecuted 21 appeals, with accompanying briefs, to the Secretary of the Interior from adverse decisions of the commissioner, and made 5 oral arguments before the Secretary. Depositions were taken by the office in 75 cases. Regulations for the administration of the National Forests were revised during the year and upward of 50 proclamations and Executive orders eliminating lands from the National Forests were either prepared or passed upon by the office. The office handled 406 cases of grazing, timber, fire, and occupancy trespasses on the National Forests. Those which were concluded favorably to the Government during the year resulted in the payment into the Treasury of \$67,322.54, and in several criminal cases substantial jail sentences were imposed. Punitive, in addition to actual, damages in the sum of \$704.70 were recovered during the year in cases involving illegal grazing on the forests. The office passed upon 56 applications for power permits and heard 2 oral arguments of attorneys for applicants for conflicting permits. Upward of 60 complaints, briefs, and indictments were prepared at request of the United States attorneys during the



year; 123 claims for relief and reimbursement under the appropriations made by Congress in consequence of the forest fires in the fall of 1910 were examined by the office; and 39 contracts for the purchase of lands for the protection of watersheds of navigable streams under the act of March 1, 1911, were prepared during the year.

#### TWENTY-EIGHT-HOUR LAW.

Six hundred and thirty-one violations of the 28-hour law were reported for prosecution, as compared with 598 cases reported in the fiscal year 1911. Penalties were recovered in 357 cases, amounting to \$28,400. Costs were assessed against the defendants in these cases amounting to \$2,937.13. In the fiscal year 1911 penalties amounting to \$26,075 were recovered in 258 cases, with costs in the sum of \$5,783.85. There were 967 cases pending at the close of the year, as compared with 807 cases pending on June 30, 1911.

#### LIVE-STOCK QUARANTINE ACTS.

One hundred and thirty-five violations of the live-stock quarantine acts were reported for prosecution. Of these, 124 were violations of the act of March 3, 1905 (33 Stat., 1264), and 11 were violations of the act of May 29, 1884 (23 Stat., 31). The total number of cases of this class exceeded the number reported during the preceding fiscal year by 35 per cent. Fines aggregating \$6,125 were imposed in 68 cases prosecuted during the year, and the costs of the proceedings were uniformly assessed against the defendants. In 1911 fines were imposed in 51 cases, amounting to \$5,580.

#### MEAT INSPECTION.

Eighty-five violations of the meat-inspection amendment (34 Stat., 674) were reported for prosecution, a decrease in number of 16 as compared with the fiscal year 1911. Sixty-five cases were prosecuted successfully during the year, and fines were imposed amounting to \$4,746.75. In 3 cases sentences of imprisonment were imposed. In the fiscal year 1911 fines amounting to \$3,240 were imposed in 43 cases. Four cases resulted in verdicts for the defendant in the fiscal year 1912. In 1911 but 1 case was terminated adversely to the Government. At the close of the fiscal year 71 cases were awaiting prosecution.

#### INSECTICIDE ACT.

The first apparent violation of the insecticide act of 1910 was reported for prosecution in December, 1911. In all, 58 cases under this statute were reported during the year. Six of these cases resulted in convictions, and in one a decree of condemnation and

forfeiture was entered. The goods in the latter case were subsequently released to the claimants under bond after payment of the costs. The Insecticide and Fungicide Board has completed its organization for obtaining evidence of violations of this statute.

#### LACEY ACT.

Thirty-four cases involving the unlawful shipment of game were reported for prosecution under the Lacey Act (secs. 242 and 243, Penal Code). The Biological Survey has arranged, through cooperation with State officials, to trace such shipments more effectively, and it is expected that this plan will contribute materially to the detection of violations of this statute. Six cases presented during the year 1912 resulted in convictions. In one case the defendant was acquitted.

#### OTHER WORK.

Three hundred and fifty-seven contracts and leases were prepared for the several bureaus, offices, and divisions of the department, in addition to those prepared for the Forest Service in the field. During the fiscal year 1911, 339 contracts and leases were prepared for the same bureaus, offices, and divisions.

Nineteen applications for letters patent on inventions of employees of the department, for dedication to the public, were filed in 1912, more than double the number filed in 1911. Ten patents were allowed during the year and 2 were disallowed. In 1911, 10 patents were allowed and there were no disallowances.

During the fiscal year ending June 30, 1912, 20 claims for balances due the estates of as many employees of various branches of the department who died intestate were examined, the necessary papers prepared for the payment of the same, and advice furnished administrative officers of the department relative thereto.

#### PUBLICATIONS OF THE OFFICE.

In addition to the 655 Notices of Judgment published by authority of section 4 of the food and drugs act and discussed in detail in another part of this report, the office issued 11 circulars, embodying decisions of the courts construing the statutes intrusted to the department for execution. Six of these embodied decisions on cases arising under the 28-hour law, 3 under the food and drugs act, 1 under the National Forest administrative act, and 1 a decision of the Attorney General under the meat-inspection law. There was also published during the year a supplement to the annotated edition of the 28-hour law issued on October 2, 1909, thereby bringing up to date the original edition. The office also published a compilation of references to the legislative history of acts of Congress enforced by

the department for use in connection with the construction of any of the provisions contained in such statutes.

At the close of June 30, 1912, the office had in preparation a revision of the compilation entitled "Laws Applicable to the Department of Agriculture," the first edition of which was published in 1908, and embraced a compilation of all statutes, in effect at that time, applicable to the Department of Agriculture. There was also in preparation an appendix to the Use Book of the Forest Service embracing all of the general laws, reference to which is found necessary in the daily administration of the National Forests.

### WEATHER BUREAU.

#### INVESTIGATION AND RESEARCH.

A series of practically continuous explorations of the upper atmosphere extending over the last five years has been concluded at the Mount Weather Observatory with highly satisfactory results. It has been shown beyond question that the meteorological conditions disclosed by kite flights are often susceptible of utilization in the preparation of weather forecasts. The data for the five-year series of observations are in course of summarization and will soon be in suitable form for further study. A report on the sounding-balloon ascensions made in the Western States in 1909, 1910, and 1911 has also been completed and published in the Mount Weather Bulletin. On the whole, this report forms the most important contribution to the meteorology of the higher atmosphere thus far made in this country. The atmospheric conditions at extremely high levels as disclosed by the balloon flights are not wholly in accord with the conditions that have been found to exist at similar levels over continental Europe. It is evident that further explorations of this character will be necessary in the United States to confirm the results arrived at in the report mentioned.

Studies of temperature conditions on mountain tops and in adjacent valleys have been continued at Mount Weather and elsewhere and the conclusions relating thereto published in the Mount Weather Bulletin. The results obtained have tended to fix the relation between prevailing weather conditions and the character and degree of temperature changes that may be expected to follow in the valleys below. These studies have an important bearing on the question of air drainage and, in their practical application, to the protection of fruit in the valleys and on mountain slopes given over to its production.

#### FORECASTS AND WARNINGS.

The forecasts and warnings issued by the Weather Bureau for all interests liable to be affected by coming weather conditions were veri-

fied in every important instance. The world-wide survey of atmospheric conditions presented by the synoptic charts for the northern hemisphere has continued to be of great value in the preparation of general weather and temperature forecasts for the United States for a week in advance. During the year the field of observation over the northern hemisphere was materially extended, reports having been added from the Aleutian Islands by wireless and from stations in Japan and China by cable. Cable observations are also being received daily from an increased number of stations in Russia.

By direction of the Secretary the Chief of the Weather Bureau visited England during the year for the purpose of taking part in the International Radiotelegraphic Conference held at London on June 4 to July 6, inclusive. As a result of his intercessions, which were indorsed by all the delegates from the United States, the conference agreed to an international regulation which shall give weather observations the right of way over all messages except distress calls. This is an important regulation and will make it possible in time to organize complete ocean weather services, the value of which to life and property through the issue of warnings to shipping at sea can not be estimated. A valuable extension already inaugurated in the weather service is the receipt by radiotelegraphic communication of reports from vessels at sea along the middle and south Atlantic coasts and in the Gulf of Mexico and Caribbean Sea, those being the regions traversed by tropical storms before reaching our coasts. With the further perfection of the wireless service these reports will become of increased importance.

Among the more striking weather features successfully forecast during the year were: The cool weather following the prolonged hot wave in July, 1911; the hurricane of August along the Georgia and Carolina coasts; the freezes in the west Gulf States in November; the severe freeze in California during December; the record-breaking cold wave of January; and the heavy snowfalls in the Middle West during the winter of 1911-12. The warnings issued in advance of the two severe freezes in the west Gulf States in November enabled sugar, orange, and truck growers to protect crops to the value of several million dollars that would otherwise have been lost. During the December freeze in California the citrus crop, valued at \$40,000,000, suffered damage to the amount of about \$6,000,000. This loss resulted from an inadequacy of facilities for general smudging. Where smudging was done, not only the fruit buds but trees in bloom were saved from injury. But for the frost warnings of the Weather Bureau at this time and the cooperative efforts of the orange growers the loss would have approximated \$20,000,000.

## RIVERS AND FLOODS.

The flood in the lower Mississippi River during the spring and early summer of 1912 was the greatest in its history, and entirely overshadowed similar disasters in other portions of the country, although numerous and widespread floods occurred elsewhere during the year, the Pacific Coast States alone escaping on account of deficient precipitation. In the Mississippi flood all previous high-water marks were exceeded from Cairo to the Passes except in the vicinity of Vicksburg, Miss. The flood began in March and reached its maximum at New Orleans, La., early in May; at the end of June the flood waters were still flowing through the Hymelia crevasse above New Orleans. Of the entire territory subject to overflow about 17,600 square miles, or 59 per cent, were flooded. The losses are believed to have reached \$75,000,000, and may possibly reach \$100,000,000, the greater portion representing the loss of the season's crops. In its forecast of flood stages and its warnings of danger to residents in the threatened territory the bureau maintained the high degree of accuracy characterizing its previous flood work on the Mississippi River. Through the flood warnings many lives were saved. The forecast for the highest stage in the river at New Orleans was issued nearly five weeks in advance, and its absolute accuracy, despite complications caused by crevasses and subsequent heavy rains, was a triumph of forecasting skill. A report on the Mississippi flood, already begun, will be prepared jointly by the Department of Agriculture, the War Department, and the Department of the Interior, each department dealing only with such features as come within its particular province.

Floods elsewhere were forecast with the usual timeliness and accuracy. The total flood losses reported during the year were about \$86,000,000, of which about \$11,000,000 were incurred outside the lower Mississippi Valley. These figures are far from complete; it is reasonably certain that if all losses were reported and more detailed statements obtained the total would be brought up to at least \$110,000,000, against a total of less than \$8,000,000 for the year ended June 30, 1911, and of about \$14,000,000 for the year before. The total value of property saved through the flood warnings of the past year is estimated at \$19,000,000.

The measurement of the winter snowfall was continued in the mountain regions of the West as a basis for the forecasting of the amount of water likely to be available for agricultural and commercial purposes during the succeeding spring and summer. While this work is still in an experimental stage, the forecasts based on the surveys and measurements made in the Maple Creek (Utah) watershed in the spring of 1911 were of much value to water users, and

the surveys and measurements made in the spring of the past year promise equally valuable results.

The study of the effect of forests on climate and stream flow has been continued in the Rio Grande National Forest, Colo., during the past year, and complete data for nearly two years have now been obtained. It was at first thought that this study, carried on at a great elevation and in a supposedly semiarid region, would not afford a basis for legitimate comparison with data obtained from the more humid regions of the East, but it now appears that the final results will permit of more general application than was earlier supposed. Observations of a similar character, though more limited in scope, are being made in other national forests in Minnesota, Idaho, Colorado, Utah, Arizona, and California.

#### OBSERVATIONS AND REPORTS.

The observations and reports furnished by the 197 regular Weather Bureau reporting stations of the first order form, in the main, the basis for the weather maps and general daily weather information issued to the public. In addition to these, however, there are 75 special meteorological stations that render telegraphic reports and that are maintained as adjuncts to the work of the forecaster in making special frost predictions for the fruit, truck, vineyard, and cranberry interests of the various portions of the country. Of the 158,636 telegraphic observations due from these stations during the year, only 1 was missed, and that through an accident to the observer.

Of the special services devoted to the interests already mentioned, that carried on in relation to the fruit industry has been given the greatest extension during the year. These extensions have been made largely in California, Oregon, Washington, Idaho, Utah, Colorado, and North Carolina. In North Carolina numerous "orchard" stations have been established, and a special investigation is being made in the Blue Ridge Mountains in regard to the thermal belts that are particularly favorable for the development of the fruit industry, owing to their practical immunity from damaging frosts. In addition to the services already mentioned, observations were taken at more than 400 special stations in the corn, wheat, cotton, sugar, and rice growing States, and daily statements of temperature and rainfall were issued during the growing season in the interest of the staple crops produced in the districts covered by the reports. There are also about 4,000 cooperative stations at which daily observations of weather and temperature are made and from which monthly reports are received by mail. These reports are of value in establishing the climatic conditions of the country.

The distribution of Weather Bureau forecasts and warnings has been extended wherever practicable during the year, by means of the

telegraph, telephone, and mail service, the total number of persons receiving the forecasts daily by telephone alone being estimated at more than 5,000,000 at the close of the year.

The distribution of daily weather information by means of weather maps was largely increased through the extension of the publication of weather maps in the daily newspapers. This form of issue is now being made in 147 papers, with a total daily circulation to nearly 3,000,000 subscribers.

#### MARINE WORK.

The Weather Bureau has continued the preparation of meteorological charts of the North and South Atlantic, North and South Pacific, and Indian Oceans, and of the Great Lakes. These are published monthly, except the South Atlantic and South Pacific, which are issued quarterly. The charts portray graphically the meteorological elements over the oceans and contain much additional information of interest to mariners. The meteorological data upon which they are based are collected from vessels of all nationalities. During the past year 2,291 vessels, representing 24 different nationalities, cooperated with the Weather Bureau by furnishing reports of observations; reports were also received from 261 land stations, making a total of 2,552 cooperating marine observers.

On April 1, 1912, the Weather Bureau inaugurated on the Atlantic and Gulf coasts a vessel weather service on 30 vessels sailing between New York and New Orleans and points in the West Indies. These vessels are equipped with barometers, and take observations twice daily when 70 miles or more from the port of departure or port of entry. These observations are radiographed to the nearest wireless station on the coast and sent thence over the land lines to Washington, where they are utilized in the preparation of weather forecasts and warnings. A vessel weather service has also been started on the Pacific coast. Arrangements have also been made for the broadcast dissemination of forecast messages and storm warnings over the ocean, to the extent that the present service will permit, through cooperation with the Naval Wireless, the United Wireless, the Marconi, and the United Fruit Telegraph services on the Atlantic, Gulf, and Pacific coasts.

A vessel-reporting service, providing for the prompt transmission of communications between interested organizations and individuals regarding passing vessels, wrecks, and marine disasters, has continued in operation at the Weather Bureau stations at Block Island, Cape Henry, Sand Key, Southeast Farallon, Point Reyes Light, North Head, Port Crescent, and Tatoosh Island. This service is especially comprehensive in its operation at the Cape Henry station, which reported not less than 19,876 passing vessels during the year.

Numerous instances were reported where the Weather Bureau observers on the lookout at these reporting stations sighted vessels in distress and sent out the word that brought the revenue cutters and the tugs of wrecking companies to the rescue.

#### NEW APPARATUS.

Rain and snow gauges having special shield devices were installed for comparative observations at stations in Colorado, Yellowstone Park, and Utah during the year. In all cases the records of snowfall obtained from these gauges were from 20 to 25 per cent greater than those obtained by the ordinary snow gauge. Further structural modifications will be made in these gauges in order to overcome difficulties that are still encountered in the effort to obtain a catch that will represent the true amount of precipitation.

Special instrumental equipments were installed at stations in Minnesota, Idaho, Utah, and California, in connection with experiments being carried on in cooperation with the Forest Service.

Instruments for obtaining records of humidity and temperature have been supplied to the Bureau of Mines for use in a study of the causes and prevention of mine disasters.

The study of conditions favorable for the formation of frost in the fruit districts of the country has called for a large distribution and installation of instruments at the special observing stations.

Weather Bureau kiosks constructed for the display of weather instruments at conspicuous places in large cities were furnished to 10 additional stations during the year.

The development of special apparatus for the measurement of solar radiation was extended during the year, and a number of stations in the West and Southwest were equipped with pyrheliometers for the purpose of making observations.

Special instrumental devices for the study of wind movement at high velocities have been developed during the year. By means of the tests proposed through their use it will be possible to determine the higher wind velocities more accurately than now secured by means of the cup anemometer, it being recognized that the velocities as at present obtained are increasingly erroneous with the increase of the rate above 50 to 60 miles an hour.

#### SCHOOL OF INSTRUCTION.

There has been established at Mount Weather a school of instruction at which newly appointed assistant observers will be given a thorough training in the meteorological and other duties to which they will later be assigned. The observation station will be conducted exactly as a regular station of the bureau. The course of instruction includes a training in observational methods and the



preparation of meteorological reports and in the construction and upkeep of meteorological instruments.

### BUREAU OF ANIMAL INDUSTRY.

#### THE MEAT INSPECTION.

The meat inspection, which is carried on at slaughtering and packing establishments engaged in interstate or export trade, continues to show an increase in volume and has about reached the limit of the standing annual appropriation of \$3,000,000 made by the law of 1906. To provide for the future extension of this work, which is necessary if it is to be applied to all products and establishments coming within the law, an increase of \$300,000 has been requested in the estimates for appropriations for the coming fiscal year.

During the fiscal year 1912 inspection was conducted at 940 establishments in 259 cities and towns. There were inspected at time of slaughter 59,014,019 animals, consisting of 7,532,005 cattle, 2,242,929 calves, 34,966,378 hogs, 14,208,724 sheep, and 63,983 goats. This constitutes an increase of over 6,000,000 in the total number of animals inspected as compared with the preceding year. The greatest increase was in hogs, of which over 5,000,000 more were slaughtered in 1912 than in 1911. There was a slight decrease, however, in the number of cattle. On account of disease or other unwholesome condition 203,778 entire carcasses and 463,859 parts of carcasses were condemned, making a total of 667,637 carcasses condemned wholly or in part. The condemnations were as follows: Cattle, 50,363 carcasses, 134,783 parts; calves, 8,927 carcasses, 1,212 parts; hogs, 129,002 carcasses, 323,992 parts; sheep, 15,402 carcasses, 3,871 parts; goats, 84 carcasses, 1 part. Tuberculosis continued to be the cause of a high proportion of condemnations of cattle and hogs. In addition to the foregoing condemnations at the time of slaughter there were condemned on reinspection 18,096,587 pounds of meat and meat food products that had become unwholesome or otherwise unfit for food since the inspection at the time of slaughter.

Inspection certificates issued for exports of meat and meat food products during the year covered 1,114,279,558 pounds. This was a slight increase over the preceding year. Farmers and retail butchers and dealers are exempted from inspection by the law, but supervision is given to interstate shipments by such persons. During the past fiscal year 116,536 shipments were made by retail butchers and dealers holding certificates of exemption, the products so shipped amounting to 20,493,837 pounds.

During the year 26,889 samples of various products were examined in the meat-inspection laboratory for the purpose of detecting prohibited preservatives or coloring matter, adulterants, and unwhole-

someness of various kinds, and passing upon the purity of condiments, water supplies, etc. The results show no attempts to use prohibited preservatives and coloring matters. The condemnations resulting from laboratory inspection have been made principally because of rancidity of oils and fats and the use of cereals in prepared meats without proper declaration on the label.

By comparing the census figures and the department's statistics it is calculated that in 1909 (the year covered by the last census) 58.12 per cent of all the meat slaughtered in the country was Federally inspected. As the Government inspection has been slightly extended in the subsequent three years, it is estimated that the proportion slaughtered under Federal inspection at the present time is about 60 per cent. Most of the uninspected remainder consists of slaughter by local butchers and by farmers.

#### HORSE BREEDING.

The horse-breeding investigations in Colorado, Vermont, and Iowa have continued with good progress. In the Colorado experiments in breeding carriage horses there were in the stud at the close of the fiscal year 77 animals, including 22 stallions and 55 mares. Of 14 foals dropped during the year 11 are alive and thrifty. The average excellence of the foals is above that of previous years.

At the Government Morgan horse farm at Middlebury, Vt., there were at the close of the fiscal year 69 animals, consisting of 19 stallions, 44 mares, and 6 geldings (work horses). One stallion, 1 mare, and 2 fillies of approved type and breeding were purchased in Kansas and added to the stud during the year. One of the stallions is still leased to the Massachusetts Agricultural College for breeding purposes. During the breeding season of 1912 an opportunity was given to farmers in Vermont to breed to stallions at the Morgan horse farm under the provisions of the plan for Army-horse breeding.

The culling of inferior animals is continued each year by a board of survey, so as to retain in the Colorado and Vermont studs only such individuals as conform to the desired types.

In the cooperative work of breeding gray draft horses at the Iowa Experiment Station there are 3 stallions and 9 mares. Four foals were produced during the year.

A good start has been made with the plan of breeding horses suitable for Army use, as outlined in last year's report. Two stallions were stationed in Virginia for breeding with approved mares, and during the year 38 mares were bred and 11 foals produced. It is too early to report upon the foals, but it is evident that farmers owning mares of satisfactory type are willing to have them bred to the Government stallions on the terms proposed by the Government. With the provision made by Congress this work will be extended

during the coming year, and it is hoped that within a few years a considerable number of suitable horses will be available for the Army.

#### CATTLE BREEDING.

In the breeding of Holstein cattle in cooperation with the North Dakota Experiment Station good results were obtained during the year, although the records made by the cows were not as large as during the preceding year because of shortage of feed production. Six heifers were put into the Advanced Registry during the year. A large number of grade heifers have been sold from the circuit, and the surplus pure-bred bulls have been sold readily, most of them going to farmers in the immediate vicinity. The benefits of the work are therefore not confined to the herds in the circuit.

A substantial increase in the production of milk and butterfat was made by the herds in the cooperative experiment in breeding milking Shorthorn cattle at the University of Minnesota. There has been an increase of almost 1,000 pounds of milk per cow during the last two years. At the end of the fiscal year the department's cooperation in this work ended.

#### SHEEP AND GOATS.

Experiments in sheep breeding are being carried on in Wyoming, Vermont, and Maryland. In the Wyoming investigations, in which an effort is being made to improve the wool and mutton qualities of range sheep, the wool clip of the past year was the best in quality obtained since the experiment was inaugurated, although the average weight was slightly less than in the preceding year. The Southdown flock, at the Morgan horse farm at Middlebury, Vt., has done well. A good lamb crop was secured, and the wool clip was the best since the flock was founded.

Experiments in breeding sheep and goats are also in progress at the farm of the Bureau of Animal Industry at Beltsville, Md., where various breeds are being crossbred with Barbados and Karakule sheep. The object of the goat-breeding experiments is to obtain a strain of milking goats. An exceptionally good crop of kids was obtained this year.

#### POULTRY AND EGG INVESTIGATIONS.

The experiments in breeding Barred Plymouth Rock fowls for increased egg production at the Maine Experiment Station are approaching a close, as the final solution of the main features of the problem of the inheritance of egg production has been reached. These results will be made available in publications.

Studies of the commercial fattening and marketing of poultry in the West have been continued and some of the results published.

In the endeavor to reduce the loss from bad eggs the department advocates the production of infertile eggs; that is, eggs from hens that are not allowed to run with male birds. It is estimated that the losses from bad eggs amount to \$45,000,000 a year, and that one-third of this is caused by the formation of "blood rings" due to the development of the germs in eggs by heat. If farmers and poultrymen will produce infertile eggs, this part of the loss can be prevented, and the losses can be further reduced by proper methods of handling and marketing. What is known as the "loss-off" method of buying eggs—that is, buying on a quality basis—is advocated, and cooperative work to establish this method has been carried on in some of the leading egg-producing States. Publications, including a poster, have been issued showing the advantage of producing infertile eggs.

#### THE ERADICATION OF ANIMAL DISEASES.

Continued progress was made during the year in the systematic work of eradicating certain diseases of live stock. As a result of work which is being carried on in cooperation with State and local authorities for the eradication of the ticks which transmit the contagion of Texas fever of cattle, 22,827 square miles of territory in the South were released from quarantine, and since the close of the fiscal year 2,248 additional square miles have been released. The total area freed from ticks and released from quarantine since the beginning of this work in 1906 now amounts to 164,896 square miles, which is nearly one-fourth of the total territory infested at the time the work was begun. The pioneer work is naturally the hardest part of the task, and it is believed that with adequate appropriations more rapid progress can be made in the future. It is evident that the days of the tick are numbered and that the South will soon enter upon an era of the development of stock raising and will have a large part in meeting the needs of our people for a greater supply of meat.

The work of eradicating scabies of sheep and cattle in the West, which has been under way for many years, is nearing completion. The area released from the sheep scab quarantine during the fiscal year amounted to 9,177 square miles.

An outbreak of dourine among horses appeared in Iowa early in the summer of 1911 and has been entirely eradicated, although horses involved in the outbreak had been as widely scattered as Texas, Arkansas, and Canada.

#### TUBERCULOSIS.

Further experiments in the vaccination of cattle to prevent tuberculosis confirm the previous conclusion that this method is not safe and can not be recommended in the present stage of its development.

Such vaccination involves the use of living tubercle bacilli of a mild strain, and it is found that these mild germs sometimes remain in the vaccinated cattle for some years and are discharged in the milk. It appears, therefore, that the result of such vaccination would be to harbor the infection in a mild form in some cases.

The bureau has continued its work for the suppression of bovine tuberculosis by applying the tuberculin test in certain sections of the country where cooperative arrangements have been made with State and city authorities, and also by testing breeding and dairy cattle for interstate shipment. The testing in Virginia and Maryland shows over 18 per cent of tuberculous cattle among those tested for the first time, and only 3 per cent in herds to which the test had been previously applied and from which the reacting animals had been removed. In the District of Columbia the proportion of tuberculous cattle on first test in previous years was nearly 19 per cent, but on retests made during the past year it was only a little over 1 per cent. As a result of this work a large number of previously infected herds are now being maintained free from tuberculosis.

#### HOG CHOLERA.

Officials in various States and farmers and stock raisers generally have shown increased interest in the work of combating hog cholera through the use of the serum developed by the Bureau of Animal Industry. At the present time 30 States are distributing serum. In most of these States the serum is prepared in official laboratories, but a few of the States purchase their supply from private manufacturers and distribute it to the farmers at cost. In some of the States preparing their own serum no charge is made to the farmers for the serum, while in other States the cost price of manufacture is charged. Up to this time considerably more than 1,000,000 doses of hog-cholera serum have been manufactured and applied in all of the various States combined, and the results are reported by State officials generally as being very satisfactory.

The demand for hog-cholera serum has been greater than could be met by the State laboratories and has led to its preparation by commercial firms. In order to insure that only a reliable quality of serum is sold in interstate commerce it is desirable that the department should be given legal authority to supervise the preparation of the serum.

The scientific investigations of the past year with regard to hog cholera have been devoted to determining the best methods of preserving by means of chemicals the hog-cholera virus that is necessary in the production of the serum. Experiments have also been made to learn whether or not the offspring of immune sows are likewise

immune to hog cholera, and it seems evident that pigs from such sows are themselves immune at birth and that this immunity lasts for at least three weeks.

#### INVESTIGATION OF OTHER ANIMAL DISEASES.

The scientific staff of the Bureau of Animal Industry has continued the investigation of the causes and nature of various diseases of live stock. Perhaps the most important work of the year has been that relating to infectious abortion. This disease rivals tuberculosis as a plague of the cattle industry. The germs causing infectious abortion frequently occur in milk, and have also been found in the tonsils of children, where they have probably been conveyed by milk. Inoculation experiments show that these germs have the power to produce distinct lesions in guinea pigs. Just what effect this organism may have on human health has not yet been determined, but our present knowledge seems to afford another reason for the pasteurization of milk as a safeguard against various infectious diseases.

What is known as the complement-fixation test has been found to be an exceedingly reliable and prompt means of diagnosing certain diseases the determination of which has hitherto been attended with some uncertainty and delay. The bureau has extended the use of this test to a number of diseases.

That rabies (or hydrophobia) is a continued menace is shown by the fact that 183 animals suspected of having this disease were sent to the pathological laboratory for diagnosis, of which 112 cases were found to be positive. While most of the cases occur in dogs, an unusually large proportion of cats were received. The best known means of getting rid of this disease is the muzzling of all dogs for a sufficient period. Muzzling orders are sometimes issued, but it is difficult to secure their thorough enforcement.

Among other diseases concerning which investigations were made during the year are forage poisoning, or cerebrospinal meningitis, swamp fever, dourine, tetanus, chronic mastitis, and Malta fever. It seems that the latter disease has existed among goats in Texas and New Mexico for many years. It is passive in goats, but causes serious illness in man, to whom it is communicated from the goats. It is important that steps should be taken to eradicate this disease from the goats, especially since there is a growing tendency to use goats' milk as food for infants and invalids. The infection of man may be guarded against by pasteurizing goats' milk where there is any reason to suspect that the infection may be present.

#### DISTRIBUTION OF VACCINE, ETC.

During the year 1,340,380 doses of blackleg vaccine were prepared and distributed to stock raisers by the Bureau of Animal Industry.

Reports of the use of this vaccine continue to show the same favorable results as reported in previous years, when the death rate showed a reduction to less than one-half of 1 per cent.

Tuberculin and mallein are furnished to State, county, and municipal officials for the diagnosis of tuberculosis and glanders, respectively. During the past year 329,771 doses of tuberculin and 135,699 doses of mallein were sent out.

#### EXPORT AND IMPORT ANIMALS.

During the fiscal year there were made 209,715 inspections of American and 27,270 inspections of Canadian animals for export. The number of animals actually exported was 142,564. The greater number of inspections is accounted for by the fact that many of the animals were inspected two or more times. This work also includes the supervision of vessels, of which 314 inspections were made.

For shipment to Canada there were inspected and tested with tuberculin 858 cattle, and inspected and tested with mallein 25,110 horses and 1,426 mules. There were also inspected for shipment to Canada 58,783 sheep, 234 goats, and 39 hogs. For shipment to the Hawaiian Islands there were tested with tuberculin 130 cattle and with mallein 317 horses and 346 mules.

A strict inspection, with quarantine in certain cases, is maintained over all animals imported from foreign countries, in order to exclude the numerous animal diseases which are prevalent in other parts of the world. For this purpose hay, hides, wool, etc., are also inspected and disinfection required. The total number of import animals inspected during the year was 379,822, and of these 3,542 were quarantined in accordance with the regulations.

#### DAIRY FARMING.

The work for the development and improvement of dairying in the South has been continued, and similar work has been extended in the West. The object is to introduce dairying in new sections and to improve dairy methods, including the breeding and feeding of the herds, as well as the handling of the milk. This work is being done in cooperation with State authorities and institutions. There is a particularly fine field for dairying in the irrigated regions of the West where alfalfa is produced. In the South and West 167 silos were built as a result of their advocacy by the department. A larger number are contemplated for the coming year. In some regions the silo is practically unknown, and when one is built it serves as an object lesson to the entire community.

Dairy farmers are also encouraged to keep accurate records of their herds, so that they may know which animals are profitable and

unprofitable and get rid of the latter. By this method the breeding of herds is steadily improved, better feeding methods are adopted, the average production of cows is increased, and greater profits are obtained.

The cow-testing association is another means of promoting the improvement of dairy herds, and embodies also the keeping of herd records. There are now 97 active cow-testing associations in the United States out of 118 which have organized since 1905. One of the greatest difficulties is to secure efficient men to supervise the associations.

#### MARKET MILK INVESTIGATIONS.

The work for the improvement of market milk has been continued and consists mainly in introducing and maintaining the score-card system of inspection, assisting in competitive exhibitions of milk and cream, and investigating the conditions surrounding the milk supply in various places. During the year cooperative work has been carried on with 21 cities and 11 States. Practically all cities in the country are now using some form of score card; the department has records of 170 such cities. Some of the handicaps to obtaining a milk supply of good quality are that municipalities fail to provide sufficient funds, the inspection work is sometimes made inefficient by political domination, and consumers fail to appreciate the fact that the production of clean milk involves additional expense. In campaigns for better milk the attempt is too often made to place the entire cost of improvement on the producer. Some incentive ought to be offered to the producer to supply the higher grades of milk. The fact is that most consumers are not demanding a high grade of milk, especially when this involves slight additional cost. It is well recognized that the health authorities of the country generally are seeking to give the public a higher grade of milk than the public is demanding or is willing to pay for.

#### DAIRY MANUFACTURES.

Work is being conducted with a view to assisting creameries in better methods of operation and business management and in improving the quality of their products. Reports were received from 1,500 creameries during the year, and on the basis of these reports advice has been given by correspondence and sometimes by visits for the purpose of remedying defects and bringing about needed improvements. The grading of cream is recommended as a method of securing better cream and producing better butter. Although there has been some improvement, a great deal of inferior cream is still



received at creameries and buying stations, and much of this is utterly unfit to be made into a food product. Investigations during the year showed that 61 per cent out of 1,554 lots of cream were of third grade—that is, dirty, decomposed, or sour—and that 94.5 per cent of the creameries investigated were insanitary to a greater or less degree. Pasteurization was practiced in only 27 per cent of the creameries. These conditions make a system of inspection of dairy products very desirable. Recommendations on this point are contained in the report of the Chief of the Bureau of Animal Industry.

#### DAIRY RESEARCH LABORATORIES.

The dairy research laboratories have continued their work upon various technical problems connected with milk, butter, and cheese. Extensive experiments regarding the influence of breed, individuality, and feeds on the composition of milk are under way at Columbia, Mo., in cooperation with the State agricultural experiment station, and some of the results of this work are in course of publication.

Work on the manufacture of butter for storage has been completed, and the results consistently show a much higher keeping quality in butter made from sweet pasteurized cream than in butter made in the usual way. Aside from the commercial advantages, butter made by this method is much safer for human health, as pasteurization removes the danger from disease germs that are liable to exist for considerable periods in butter made from unpasteurized cream.

The investigations concerning the Swiss, Cheddar, Camembert, and Roquefort types of cheese have been continued and additional knowledge has been obtained which will be of value in the production of those kinds of cheese. The experiments with European varieties of soft cheese have been carried far enough to indicate the possibility of making cheese of the Camembert type in this country, although no manufacturer has appeared to be entirely successful as yet.

#### BUREAU OF PLANT INDUSTRY.

A review of the work of the Bureau of Plant Industry for the fiscal year 1912 is included in the Record of Sixteen Years, see pages 117 to 144.

#### BUREAU OF CHEMISTRY.

#### POULTRY AND EGG INVESTIGATIONS.

The conservation policy of this department is being extended to the saving of foodstuffs that are now wasted, so that our people may continue to have enough wholesome food to eat. The farmer produces a good article, but because of deterioration during marketing it is sometimes an inferior food when it reaches the consumer, or, worse still,

it is destroyed as unfit for food before marketing. The Food Research Laboratory is studying the preservation of quality in perishable products as well as the prevention of decomposition.

Better methods have been devised for the handling of dressed poultry from producer to consumer and their adoption by the industry is growing. It is this phase of the work, however, which must be pushed if the scientific findings of the laboratory and field experimentation are to yield more food and better food to the people and surer returns to the industries. Years of study have shown that in most instances it is comparatively easy to determine in the laboratory and by experimental observation wherein the shipper errs or the middleman fails; it is an extremely difficult matter to get this information to the shipper or middleman in such wise that he will understand, believe, and apply it. The publication of accounts of the work is helpful, but personal contact between the investigators and the industries is infinitely more effective. Visits to individual packing houses are most prolific of results, but comparatively few people can be reached in this way. Addresses at meetings and conversations with their representatives are the most helpful and economical means now had for reaching a large number of people. Last year about 7,500 people, including producers, shippers, railroad men, warehouse men, food inspectors, health officers, educators, and consumers, were interviewed, and 137 packing houses which are handling eggs and poultry visited.

A field branch has been maintained in Tennessee for more than a year, during which time, in Kentucky and Tennessee, the number of packing houses equipped with mechanical refrigeration, without which it is impossible to handle poultry and eggs well, has increased from 2 to 6, and the tonnage from 48 to 160, and a number of additional plants are being seriously planned, with a consequent increase in tonnage. The poultry and eggs shipped from the up-to-date houses using improved methods have lost the name of "southern" and are in demand in northern markets, where they command good prices. It is also possible and profitable for these houses to ship to the North the entire year instead of allowing the eggs to rot on the farms and the poultry to accumulate, because the hot season is of long duration and the decay very heavy.

During the year a traveling refrigerator has been made by the installation of mechanical refrigeration in a refrigerator car. This permits the taking of improved methods into rural districts, where it is otherwise impossible to convince the people what good handling, combined with refrigeration, can do for their produce.

Information has been given the consumer to aid him in his purchase of good and economical food; as, for example, the facts concerning the loss and deterioration of poultry when chilled in water and

shipped in ice. Every 20,000 pounds of dressed poultry absorbs on an average 1,300 pounds of water, and about 300 pounds of the most nutritious and appetizing food material of the flesh of the birds is dissolved out and goes down the sewer. The keeping time of "wet packed" birds is also much shorter than that of "dry packed," hence the waste from decay is much greater.

A preliminary statement of the work accomplished in the investigation of the handling of frozen and dried eggs has already gone to press. Cooperative work was carried on with six egg-breaking plants during the summer of 1911. The fundamental principles of good handling and sanitary requirements were worked out. For the egg-breaking season of 1912, four establishments were equipped to handle eggs in accordance with the new principles. The improved quality of the products has demonstrated that, so handled, frozen and dried eggs are not only wholesome, but a desirable addition to our food supplies; and, further, they preserve for use a large amount of one of our most nutritious foods which would otherwise be lost to the people. The investigation has also demonstrated most forcibly that research work, carried on cooperatively with the industries handling perishable products, can within a short space of time revolutionize the quality of a food product and conserve for the people much food material that would, without such cooperative investigation, be absolutely lost.

#### CANNING OF FOODS.

The work now in progress involves a detailed study of the canning and preserving of fruits. A special laboratory has been so equipped that it constitutes a miniature canning and preserving factory, with a bacteriological laboratory attached for the study of the organisms normally present in the fresh and decayed products.

An attempt has been made to stop the practice of partially filling the cans with food and adding a sufficient amount of water to fill to the required content. The study of the action of tin on canned foods has been continued and the results published.

#### FRUIT PRODUCTS.

During the past year the Bureau of Chemistry has installed at Los Angeles, Cal., an experimental plant known as the Citrus By-products Laboratory, which, during the coming winter and spring, will be used in testing out methods for the utilization of citrus by-products. Laboratory work gives every indication that citric acid, oils of lemon and orange, sterilized and concentrated orange and lemon juice can be produced from the cull lemons and oranges, now a waste product. In the work on the processing of Japanese persimmons it has been found that all varieties can be satisfactorily processed on a large

scale by keeping them in carbon dioxid for a time varying with the variety and the temperature. A study on a small laboratory scale has been made of the drying of fruits in vacuum, together with an absorbent for water vapor, such as unslaked lime. The fruits which have been examined for the identification of their acids in order to determine the changes of composition during their manufacture into fruit products included many varieties of apples, pears, strawberries, raspberries, blackberries, cherries, currants, gooseberries, quinces, huckleberries, apricots, and peaches. The shipping of fresh raspberries and blueberries from New Brunswick and Prince Edward Island to Boston by boat, so that they reach the factories in a badly fermented state, has been investigated and conditions improved in some cases where the factories have been moved to the Maine border. The work of the Enological Section has included studies on the composition of the ripe fruit of grapes, of the fruit of grapes during ripening, of grape juice, and of the fruit of apples. Studies with yeast organisms comprised incubation studies to determine the fermenting power at low temperature.

#### SUGAR AND SUGAR PRODUCTS.

The investigation of the maple products industry of the United States has been continued with special study of the effect of metals on the appearance and composition of the sirup, the changes in composition of maple sugar and sirup in storage, and the effect of manufacture from sour sap. Analyses have been made of cane sirup, various grades of cane molasses, and sorghum sirup to note the chemical means of differentiating these sirups from one another. About 1,120 samples were received for analysis during the year, some requiring only single determinations, but many complete examinations.

#### DAIRY PRODUCTS.

The greater part of the work on dairy products during the year was on evaporated, condensed, fresh, and dry milks, cheese, and butter. Milk campaigns were carried on at Providence, R. I., Cincinnati, St. Louis, and Philadelphia to determine the character of the interstate milk shipped to those cities. It is believed that this work has been of great assistance to the local authorities in their campaigns for a satisfactory milk supply.

#### MICROCHEMICAL STUDIES.

As a result of the field work and the enforcement of the food and drugs act regarding certain tomato products, notably pulp and ketchup, almost revolutionary changes have been taking place within the last few years in the methods of their manufacture. A large

number of manufacturers have changed or are remodeling their plants to meet the demands for a clean, sound product. The old methods have been largely abandoned, as they proved wasteful and deleterious to the product.

An investigation concerning the coloring and facing of teas was undertaken at the request of the Treasury Department. This investigation resulted in the devising of a new method for this determination, which, with slight modifications, has been adopted as the official method of the Treasury Department to be used by the tea testers of that department.

In the line of routine work, 1,298 interstate samples and 3,066 miscellaneous samples have been examined; these included spices, fruit products, dried fruits, cattle foods, eggs, nuts, sausage, mince meats, olives, candies, chocolate, cocoa products, teas, coffees, infant and invalid foods, and textiles.

#### PLANT PHYSIOLOGICAL CHEMISTRY.

The past year's work of the Plant Physiological Section has included investigations on starch and starch products, potato drying, graham flour, canning tomatoes, and baking powders containing small amounts of calcium sulphate. The special work comprised investigations in bread making and macaroni manufacture and also baking tests with flavoring extracts and with various egg products.

#### SPECIAL INVESTIGATIONS.

The study of the presence of arsenic in shellac and gelatin and other foods has been continued. A prominent feature of the vinegar work has been the determination of formic acid in vinegar adulterated with acetic acid made from pyroligneous acid. In cooperation with the various health authorities of several States, much good work has been accomplished by joint investigation and examination of the waters, oysters, and clams from various beds. As a result, many oyster sections which have shown pollution have been closed by State authorities as a source of edible oysters.

#### DRUG INVESTIGATIONS.

The Drug Division has been engaged in studying the composition, adulteration, and misbranding of drugs and chemicals, including those products imported into the United States or shipped in interstate commerce and found on our markets. Color reactions for the purity of asafetida have been established, as well as a quantitative constant in the lead number of the purified resin. The same reactions were carried out on the well-known adulterants of asafetida. Attention has been given to the estimation of morphin, showing

that morphin sulphate used in hypodermic tablets is usually adulterated with codein. The caffen investigations have been continued with special reference to certain factors modifying toxicity, such as starvation, variation of temperature, and fatigue. The action of caffen on the circulation, with special note of the drugs modifying its effect, has been studied extensively.

The total number of samples examined during the year is 1,544, of which 294 were of synthetic products, 49 of essential oils, and 392 of chemical reagents.

#### INSPECTION OF FOOD AND DRUGS.

More than 10,000 official samples of foods and drugs were collected by the inspecting force of the bureau during the past year. Approximately 1,500 factory inspections were made to secure information on the sanitary conditions of the establishments and the general practices as they affect the enforcement of the food and drugs act. The samples were referred to the inspection laboratories in Washington and the 22 branch laboratories in different sections of the country, where analyses were made to learn whether the products were being sold in compliance with the law.

In addition to the original analyses made for inspection or investigation work, check analyses were made and cases were prepared for the consideration of the Board of Food and Drug Inspection in the Washington laboratories of the bureau. The Drug-Inspection Laboratory reported 809 samples examined, of which 604 were domestic products. Of these, 132 (22 per cent) were found to be either adulterated or misbranded or both. The Food-Inspection Laboratory reported the study of approximately 5,000 analytical reports of domestic samples, most of which were by the branch laboratories. In 2,034 instances the reports showed violations of the law, and cases were prepared for the consideration of the Board of Food and Drug Inspection. About 7,800 analytical reports on the import food cases were considered, in addition to 741 special cases, 558 of which were reported to the Treasury Department as representing adulteration or misbranding under the act and 183 were recommended to the Secretary of Agriculture for release.

Other executive work in connection with the food and drugs act is the distribution of check samples, the receiving and recording of food samples sent to Washington, and the care of seeing that the proper exhibits are sent to the United States attorney concerned in each of the cases reported for prosecution.

#### WATERS.

Mineral and table waters as found at source and as they appear on the market have been examined. As a result of the examination of

202 interstate samples of water, 18 were reported to the Board of Food and Drug Inspection as adulterated, and 2 seizures were made. Of 43 import samples 8 were found to be adulterated or misbranded and their exclusion recommended. A study of the mineral springs of the United States at source has been continued, and information covering the springs of New York, New Jersey, and Pennsylvania has been made ready for publication. This is the first attempt that has ever been made to make a systematic investigation of American mineral springs. The results will be of the greatest value to physicians, users of various waters, chemists, and those engaged in the enforcement of the national food and drugs act or State laws of a similar character. A study of methods of determining lithium in mineral waters has been completed and the results published, which will be invaluable to water analysts and those engaged in enforcing food laws. Special investigations have been made of the pollution of the Potomac River and the effect of such pollution on oysters and other shellfish. More extended work must be performed along this line before the results are ready for publication.

#### INSECTICIDES AND FUNGICIDES.

The chemical work on insecticides and fungicides has included studies of the composition and methods of manufacture of these products, as well as the effect they have upon the foliage, with the idea of increasing their efficacy, suggesting methods of avoiding injury to fruit and foliage, and suggesting to the farmer or fruit grower how to prepare such products where this is practicable. Such studies as these have resulted in and will result in a great saving to the farming community, both in the initial cost of insecticides and fungicides and in the saving from using insecticides and fungicides which will not burn vegetation. During the year 293 domestic samples of insecticides and fungicides (other than cattle dips and closely allied preparations) and 25 foreign or import samples have been examined under the provisions of the insecticide act of 1910. This act was designed to prevent the misbranding and adulteration of such goods, and its good effects can already be seen by users of these commodities. Of the 293 domestic samples examined, 131 were reported to the Insecticide and Fungicide Board as adulterated or misbranded, and of the 25 foreign samples 14 were recommended for detention at the port of entry. Considerable attention has been devoted to improved and new methods for examining insecticides and fungicides, and in consequence of this work not only have the methods of examining various miscellaneous insecticides and fungicides been worked out, but methods for examining such standard preparations as lime-sulphur, Bordeaux mixture, and Bordeaux lead arsenate paste

have been materially improved. An investigation relative to the toxic effect on fruit trees of certain elements, notably copper and arsenic, which may accumulate in the soil as the result of using compounds containing these substances as sprays, has been under way for the past two years and is now practically completed and the results are ready for collation and publication. The results of this work will be of the greatest value to fruit growers and agriculturists in determining whether or not permanent injury to vegetation through the medium of the soil is to be feared from repeated application of poisonous insecticides and fungicides.

#### CATTLE FOODS AND GRAINS.

Five hundred and four samples of cattle foods and grains were examined in the course of the year in connection with the enforcement of the food and drugs act. Of these, 89 were reported to the Board of Food and Drug Inspection as adulterated or misbranded. The work on cattle foods and grains has also included the examination of various samples for the solving of such economic problems as the feeding value of forage and range crops and improved methods of handling corn after harvesting.

#### LEATHER, PAPER, ROSIN, AND TURPENTINE.

Work has been done on bookbinding, carriage, automobile, and furniture leathers showing that the same harmful practices prevalent in the tanning of sole and other heavy leathers exist among the producers of these leathers. Experiments have been continued on the utilization of waste long-leaf pine for making paper and the recovery of wood turpentine, rosin oils, and wood creosote. Standard, nonfading type samples of rosin have been devised and are expected to promote the correct grading of rosin and at the same time to prove more economical to the official graders. The work on production of wood turpentine, its refining, its value as a paint and varnish thinner, and its effect on the workmen using it in paints has been continued, and the information thus obtained will be used in new experiments.

#### EXAMINATION OF CONTRACT SUPPLIES.

The investigations of rubber goods and paint materials have been continued with good results. Attention has been given to platinum laboratory utensils and enamel-ware cooking utensils. Improved methods have been devised for testing inks and typewriter ribbons. The samples examined for other departments of the Government during the year number 2,442, in addition to 1,800 pieces of apparatus examined for the Bureau of Chemistry.



## FOREST SERVICE.

The work of the Forest Service is, of course, both investigative and administrative. The investigative work has for its field the discovery of the best methods of handling woodlands and the best methods of utilizing their products. The administrative work is that involved in protecting and developing the National Forests and in cooperating with States for fire protection of the watersheds of navigable streams under the Weeks law. While the investigative work is fundamental for the application of right methods on the National Forests as well as elsewhere, the strictly administrative work takes the lead by far in importance, as measured by volume and cost.

In my report last year I set forth in some detail the necessity of basing the administrative work on sound technical methods. It is equally necessary that the administrative policy accord with sound business principles. As use of the forests develops, certain questions of business policy are sure to come to the fore. With nearly eight years of National Forest administration behind me—years which in sober truth deserve to be called epoch-making, for within their compass a complete system of regulated use giving permanence to vast resources has been developed almost from nothing—and bearing in mind the years ahead in which that system will be tested by its results, I may well call attention at this time to the principles which underlie the present business policy and to the reasons why that policy should, in my judgment, be continued.

The National Forests contain about one-fifth of the standing timber of the country, but furnish only about one-eightieth of the annual cut. They produce by growth more than 10 times the amount of timber which is now being taken from them each year. While the forests of the country as a whole are being greatly overcut, so that our timber capital is diminishing yearly and rapidly, the National Forests are rising reservoirs of supply. The forests of the East and South particularly are subjected to an accelerating drain by the heavy demands of the general market, and to the extent that the weight of this overdemand can be relieved through the use of a greater proportion of western timber, the best permanent interests of the country will be promoted. A large part of the present stand of National Forest timber is ripe for the ax, so that the sooner it is cut the greater will be the production of new timber by growth and the less the waste through decay. All these facts point to the conclusion that the cut from the forests should be increased by every possible means.

This conclusion, however, can not be accepted unqualifiedly. There are considerations of public policy which weigh on the other side. I should have failed in my duty if I had made volume of cut my sole

object. Leaving entirely out of account the need for imposing conditions which will secure the production of the best new timber crop, it is necessary to regulate cutting with a view to the protection of the best interests of the public in the long run. Lumber is one of the things the price of which enters into the cost of living—and more largely, perhaps, than is generally realized. That cost should be kept down; but the cost of living to-morrow must not be lost sight of in dealing with the problem of the cost to-day.

Our economic dependence upon the forest is complete. Nothing is more certain than that national foresight must be employed in conserving the supplies that we have left. This is a fundamental part of the policy now in force on the National Forests. First consideration is always given to local needs. These are supplied partly under the provisions for free use of timber by settlers, prospectors, and others, partly through sales. The annual requirements of the localities in the vicinity of the National Forests at the present time may be put roughly at about 300,000,000 board feet under sales and 140,000,000 feet under free use. The amount which could be cut each year without exceeding the annual production by growth is over 6,000,000,000 feet. Most of this is therefore available as a surplus over local needs for the supply of the general market. But it is not an evenly distributed surplus. Some of the forests have no surplus at all; every foot of timber that they can supply as a sustained yield will be needed for the support of local industries now in sight. On such forests, and on forests approaching this condition, no sales whatever to supply the general market would receive consideration from me for an instant. Thus, for example, all the timber on the Deerlodge Forest, in Montana, is reserved to supply the mines at Butte. Other forests are now producing timber in enormous excess over local needs. The Cascade National Forest, in Oregon, adds through growth 200,000,000 feet a year to the available supply, while local needs now call for only about 1,000,000 feet a year. From such forests (and they are many) the general market can draw heavily without endangering local industries.

Provision is made for disposing of timber in three ways. To bona fide settlers, miners, residents, and prospectors I am authorized to allow the use of timber for domestic purposes without charge. If I sell timber to homesteaders and settlers for their domestic use, I am required to do so at actual cost. In other sales I am required to sell at not less than the appraised value, and if the sale exceeds \$100, only after public advertisement for at least 30 days.

In other words, the law now recognizes that timber from the forests should be made to contribute to the development of the country by home builders, and to the development of mineral resources by prospectors and miners, without the requirement of payment when

payment may not reasonably be expected; that if the home builder buys for his own use, the Government should seek reimbursement of expenses, not profit; but that otherwise the Government should obtain the market value of the timber, and should seek to have that value fixed by competition unless the amount involved is too inconsiderable to make the procedure involved worth while.

When National Forest timber is sold it is the duty of the Government to protect the public against monopoly. To secure a monopoly profit there must be such control of a particular market as will enable those having the control to charge an unfair price. From the beginning the Forest Service methods of selling timber have been devised with a view to preventing timber monopoly by purchasers. A fair operating profit to the purchaser in his investment is permitted, but no more. Through stumpage appraisal a minimum price is fixed, below which the timber will not be sold. This price is based on a close estimate of the cost of manufacture and the market price of the product. The sale is then advertised, and competition is sought through publicity. In advertising for bids the right is reserved to reject any bids acceptance of which would tend to establish monopoly conditions. Wherever opportunity offers, sales are made to competing firms. If it appears that monopoly control might take place through business affiliations of apparently independent operators, a certified statement of the relation of an applicant or bidder to other purchasers, or a certified statement of the membership of firms or lists of stockholders in corporations, may be required. Bids from lumber companies which have large holdings of their own may be rejected in order to give preference to companies not so supplied, and companies which are operating under one sale may be refused another sale until the first is completed. Thus by the exercise of administrative discretion in the acceptance of bids and in the location of sales a regulative principle is applied to that part of the lumber industry which utilizes National Forest supplies.

The necessity for careful provision against monopoly has become more conspicuous during the past year because of the larger bodies of timber which are now being offered for sale, with proportionately longer cutting periods. In my report for 1911 I made mention of the fact that three sales had been advertised on terms which would permit the cutting to extend over from 7 to 10 years. Such sales offer the only means by which lumbering can be extended into many districts where cutting should begin at once. Immense bodies of mature timber which should be harvested to prevent deterioration and to make room for new growth are unmarketable for lack of means of transportation. Usually railroad development is the recourse for lumbering them. Naturally no one will undertake to build from 30 to 100 miles of railroad into a mountainous wilder-

ness without assurance of tonnage for a considerable term of years. To meet this situation a large-sales policy has been worked out. It includes provision for periodic readjustments of stumpage prices, based on the changes which take place in lumber prices in the markets where the timber is sold. The result of such sales is to secure railroad development, opening the way to general economic development, in entirely new fields; to make available for early use timber, much of which would otherwise rot in the woods; and to tap additional supplies of timber which can be sold to other purchasers once the means of getting it to market has been created.

The first necessity in making such sales is that the transportation facilities developed shall be public. This is always made a part of the contract. Railroads constructed for the operation must become common carriers. Taken with the other safeguards against monopoly already described, the stipulations on this point are fully adequate to protect the interests of consumers. Two sales of this character were concluded during the year, and a score are now pending. While it is not to be expected that all of these will be put through, a large increase in the annual cut is practically assured through the adoption of the large-sales policy.

This policy in no sense supersedes that which seeks to encourage small sales. On the contrary, it not only supplements that policy but also extends the opportunity for its application. The small mill, sawing for local supply, will enter the territory opened up by the large operation as population flows in and trade, industry, and agriculture develop. Out of a total of 5,772 separate sales made last year, 5,557 were for amounts under \$500.

The general principles which guide the timber-sale business as a whole, therefore, are three:

(1) Except for sales to settlers and homesteaders who want the timber for their own domestic use, the actual market value of the timber as it stands is secured.

(2) Artificially high prices to the consumer through monopolistic control of local markets are carefully guarded against.

(3) The field of lumbering operations and the volume of cut are being enlarged wherever an opportunity exists, and new opportunities are being sought; except that the cut is not allowed to exceed the sustained annual yield, nor are sales for the general market allowed on forests where the local demand will utilize all the timber that the forest can steadily produce.

Pressure will undoubtedly be brought to bear increasingly as time goes on and market prices go up for sales on some other basis than that of the actual value of the timber. It will doubtless be said, as it has been said already, that the Government by withdrawing the National Forests from private acquisition has reduced the amount of

timber on the market and so increased the cost of lumber, and that by making purchasers pay the full value of what they buy it has levied on the necessities of the public. I have tried to point out that, far from being withdrawn from the market, the timber of the National Forests is being pushed upon the market. Ten times the quantity sold last year would have been sold if purchasers could have been found. By withdrawing the forests from private acquisition the Government has increased the amount of timber on the market, for it prevented the absorption of their finest stands by the speculators who now hold for the rise enormous quantities of the best timber in the West. By making purchasers pay the full value of what they buy the Government has simply done justice to all instead of permitting a favored few to profit at the expense of the many. While it has been collecting the actual worth of all timber sold, the Government has been doing everything that it has power to do legitimately to keep prices down by offering as much timber as possible for sale and by regulating sales to prevent the collection of a monopoly toll from the public. Any proposal looking to the sale of timber at prices below its actual market value will require to receive the closest scrutiny to discover who will in point of fact be its actual beneficiaries, and at whose expense.

#### AGRICULTURAL LANDS IN THE FORESTS.

While the National Forests comprise the great mountain regions of the West and in general have neither the climate nor the soil nor the topography that would make cultivation possible, there are exceptional localities and many scattered patches of land which are adapted to tillage. As originally proclaimed, the forest boundaries included much more land of this character than they do now. Naturally the lower-lying parts of the forests were the parts in which such lands were generally found. The early work of examining lands which were under consideration for National Forests was necessarily hasty, for a small force had to cover a great territory in the shortest possible time if the forests were to be saved to the public. In consequence the lines were drawn somewhat roughly. In places they took in too little land, elsewhere too much.

A revision of all boundaries, based on careful examinations and land classification, has been under way for three years and has resulted in the elimination of about 10,000,000 acres which were found not to be chiefly valuable for forest purposes. In making these eliminations an effort has been made to exclude all important nontimbered areas chiefly valuable for agriculture and located along the borders of the forests or running back from the borders into the forests. Many deep indentations which the maps now show indicate where valley lands extending for miles up the course of a stream have been

thus excluded. The result has been to reduce largely the amount of agricultural lands in the forests.

To a large extent fertile and relatively low-lying land included in the forests had, previously to their establishment, been taken up. This is true both of heavily timbered valleys and of open lands. The traveler passing up a valley and knowing that he is within the Forest boundary is often misled by what he sees. The land which appears to be withdrawn from agricultural development through reservation by the Government is very likely owned by a timber company or speculator. If the value of the standing timber on such land is much greater than its value for farming in its uncleared state, it is practically certain to be held primarily for its timber. Agricultural development of such land is effectively blocked not because the land is in a National Forest, but because it pays the private owner best to leave it uncleared until he can realize on the timber to good advantage. Many quarter sections of such land have on them timber worth over \$20,000.

Thus a large part of the land still left in the forests which could be cultivated successfully is accounted for. It has passed into private ownership. In spite of the fact that, in redrawing the boundaries, areas on which most of the land was alienated were so far as practicable eliminated, there are still some 22,000,000 acres of the forests which the Government does not own. Of that which the Government does own, not over 4,000,000 acres is agricultural. Of this amount a large percentage is heavily timbered. Such lands are at present not being opened to settlement, because to open them would be simply to turn them over to timber speculators. To prevent an indefinite tying up of the land because of its timber value, I shall first, and as soon as possible, sell off the timber on them, and then list them for the benefit of the bona fide homesteader.

That there was need for provision for opening lands capable of serving their best use through agriculture I early recognized. This department advocated the enactment of a law to make this possible. The necessary legislation was secured in the act of June 11, 1906. Under the terms of that act I was authorized to list for homestead entry, upon application or otherwise, lands found upon examination to be more valuable for agriculture than for forest purposes.

Since this act was passed I have listed nearly 1,250,000 acres of agricultural land. At the outset it was impracticable to do more than examine lands for which applications were made. As time passed, however, it became apparent that a systematic segregation of the larger tracts was called for. This was first undertaken in the boundary readjustments already described, and in some special classification work, particularly in northern Montana. Following completion of the field work on the boundaries, plans were formulated

for a thoroughgoing classification of areas which that work had not reached.

Agricultural development within the forests is highly desirable not only because it carries out the fundamental principle of putting every kind of land to its most productive use but also because the administration of the forests is made easier by the presence of settlers. A forest put to work is a very different thing from a wilderness. The more people it has living in it the better. They are needed to use the resources. They are also needed to help protect the forests. Settlers assist in locating fires and in putting them out. They are available for extra help in the construction of improvements and similar work. Their farms become to a certain extent bases of supply. In its plans of organized fire protection the Forest Service now arranges with settlers to take a definite part in the work, and thus forms what may be called the secondary line of defense. There is every reason why the settlement of lands more valuable for agricultural use than for forest use should be welcomed and facilitated.

A comprehensive plan of land-classification work for the general determination of agricultural lands within the forests received my approval in April of the present year. Under this plan the land will be classified on the basis of full data with regard to all important factors. Questions relating to soil will be passed upon by specialists from the Bureau of Soils. In fact, a complete scientific determination will be made not only of the relative value of the land for field crops and for forest crops, but also of the relative value of different areas for farming, and of the kind of farming that will be most successful. To this work the entire department will contribute. The applicant for land will be able to learn not merely that he may settle in a certain place, but the relative value of all lands open and the crops and cultural methods which will utilize to best advantage any specific area. In this way I believe that the principle of putting every kind of land to its best use will be carried out more effectively than has ever been possible before and with greatest benefit to those who seek to make settlement in the forests.

Partial provision for this work was made by an appropriation of \$25,000. To carry the work forward on the scale planned much more liberal provision for it should be made, and I strongly urge that the appropriation be increased.

In listing tracts for settlement a difficulty which is of serious importance in some cases is created by the need to reserve rights of way over the land. In narrow valleys a single farm may bottle up a large and valuable body of timber if no right of way exists across it, or it may block entrance to agricultural land lying beyond. When the need of a right of way can be foreseen it is now surveyed out in advance and described in the patent; this, however, is both costly

and unsatisfactory, for it can not always be told where the right of way should run. Authority should be given to the Secretary of the Interior to express in the patent the reservation of rights of way for governmental purposes and to meet the needs of settlers.

#### WORK OF THE YEAR.

With field enlarged by the extension of the work under the Weeks law, providing for the acquisition by the Federal Government of forested lands on the watersheds of navigable streams, and with a material gain in efficiency and increase in output in old lines of work, the total cost of all Forest Service activities was lowered from a little over \$5,900,000 in the fiscal year 1911 to about \$5,530,000 in 1912. The 1911 expenditures, however, included the heavy disbursements necessitated by the great forest fires in the fall of 1910. Notwithstanding this fact it is beyond question that the Forest Service got last year larger and better results for every dollar expended than ever before. This is due to the constant study of efficiency in organization and improvement of the administrative mechanism.

The work of readjusting the National Forest boundaries was continued, with the result that during the year a net reduction in the total area of the forests was effected, amounting to something over 3,000,000 acres.

In States in which it is still possible to add to the forests new areas which should be included, the boundary readjustments added last year not quite 250,000 acres. To the six States (Washington, Oregon, Idaho, Montana, Wyoming, and Colorado) in which additions to the forests by presidential proclamations are forbidden Congress added, near the close of the last session, California. The gross area of all forests at the close of the year was about 187,500,000 acres and the net area about 165,000,000 acres.

To consolidate the National Forest holdings and to provide for satisfaction of the equity of States having unsurveyed school lands within the forests, agreements providing for an exchange with the States of South Dakota and Idaho of such school lands for other lands of equivalent acreage and value, lying in solid blocks along and within the boundaries of the forests, were entered into. The agreement with South Dakota affects about 60,000 acres. Surveys to determine the area which Idaho will exchange were under way at the close of the year. Other exchanges affecting both State and private lands are pending. Legislation to permit this policy to be applied more broadly is needed.

Cooperation with the Department of the Interior through reports on mining claims within National Forests when patent is sought was continued. These examinations are the only means of protection



which the Government has against fraudulent acquisition of National Forest lands sought under the guise of mining claims for water-power sites, timber speculation, range monopoly, and other purposes. In making them, careful provision is made to safeguard all the rights of claimants, and no unfair or burdensome restrictions are imposed on the mining industry. Unfavorable reports on claims are made only after examination by fully qualified mineral examiners and practical mining men. Reports to the General Land Office on all kinds of unpatented claims covered 1,869 such claims, of which 1,534, or 82 per cent, were reported on favorably.

Receipts from the National Forests increased over \$140,000, or about 7 per cent. The major part of this increase was from the receipts from timber sales. A much more active demand for timber was apparent during the year and resulted in large sales which make certain a very large increase in future receipts from this source.

The total receipts from all sources were over \$2,100,000. Twenty-five per cent of this amount goes to the States in which the forests are located, as county, school, and road funds, and an additional 10 per cent of the receipts of last year were made available by Congress for expenditure in the States within which the receipts were obtained, for the construction of roads and trails within National Forests. These roads and trails will be primarily for the benefit of communities, and cooperation with communities will be sought in carrying out the work. At the same time the development of the forests will be to some extent aided through the additional facilities furnished. I consider this a wise and beneficial expenditure, and I recommend that the appropriation be renewed.

#### PROGRESS IN FOREST MANAGEMENT.

The total stand of timber on the National Forests, including Alaska, is now the equivalent of nearly 600 billion feet. Plans for thorough protection of this timber against destruction by fire and for the development of the forests to permit the harvesting of the mature timber, and studies of methods by the application of which the highest productivity will be assured and a constant yield provided for, were materially advanced. The progress made in constructive application of the principles of forestry, in the interest of the best public welfare, to the enormous area and widely varying conditions of the National Forests has been immense. Considering the brief time since the application of forestry by the Government began, an accomplishment quite without parallel in any other country has been achieved. How great the public service which has been rendered is, it is almost impossible to realize. Its character is fundamental, for it has established a firm and safe basis on which will be reared the future system of intensive use.

## FOREST FIRE LOSSES OF THE YEAR.

Not quite 2 acres per thousand were burned over during the calendar year 1911. On only a very small part of the area burned over was any considerable percentage of the merchantable timber destroyed. The estimated damage was about \$355,000, nearly equally divided between damage to timber and damage to reproduction and with a small loss of forage value.

During the last half of the fiscal year 1912 very few fires occurred. This was partly because of unusual weather conditions, partly because of the great gain in efficiency of protection and the development of the system of roads, trails, telephones, lookouts, and other permanent improvements. Much still remains to be done and large expenditures must be made before the forests will be safe against disastrous fires; and the present protective force is far too small. The saving of public property, to say nothing of the protection given to private property and to life which follows from efficient fire protection, makes failure to provide for such protection not merely most short-sighted economy but an almost criminal neglect. Better manned and better equipped forests are a matter of primary importance. The advance in the development of an enlightened and vigorous public sentiment on the subject of forest fires and in organized protection of private holdings in National Forest regions has been a prime factor in lowering the fire risk and is a matter of great importance. That this advance has taken place is due first of all to the example furnished by the Forest Service and to the education of public sentiment which it has brought about. An adverse influence has been temporarily created in localized regions, particularly in northern California, by the agitation of the theory of "light burning." This has brought about an increase in incendiarism in certain localities, due not to malice but to the mistaken idea that forest protection is promoted by letting fires run over the ground frequently. This would mean in the long run forest destruction, for it prevents the renewal of the forest growth.

## REFORESTATION.

Both through seeding and through the planting of young stock grown in the National Forest nurseries the work of reforestation was pushed. Under the plans which I have approved an average of 30,000 acres will be covered each year, the amount varying, however, to fit such special conditions as may present themselves. In years of unusually heavy seed crops, for example, the seed gathering will be put ahead of the sowing and planting work. About 20,000 acres was covered last year, of which about 14,000 acres was sown and 6,000 acres planted at a total cost of about \$130,000. Work on a

large scale is now centered in the regions where climatic conditions are most favorable. Elsewhere the work is primarily experimental—to discover the methods which will permit the difficult work to be accomplished most successfully and at least cost. Facilities for gathering the seed needed for direct sowing and in the nurseries were increased and the cost of seed extraction was markedly cheapened. Nearly 50,000 pounds of clean seed were collected, at an average cost of \$1.68 per pound. It was established that the best results are secured when seed from the region in which the trees are to be grown is used.

#### PROGRESS IN RANGE MANAGEMENT.

With a somewhat smaller area under grazing administration than in 1911, the number of animals grazing under permit was very materially increased. This is mainly the result of the improvement in range conditions which regulated grazing has brought about. Not only the range but also forest growths and waterflows have been benefited. Efforts were continued to bring into use range hitherto unutilized because inaccessible. In northeastern Washington, northern Idaho, and northwestern Montana, especially, much forage is now going to waste which better shipping facilities will make it possible to utilize; negotiations which have been undertaken with the railroads promise a favorable solution of this problem. Through the construction of improvements for the control of the movements of stock and to make water available for them, through continued study of the forage resource and of the modifications which it undergoes in the different forms of use, through determination of the kind of stock to which each part of the range is best adapted and adjusting use accordingly, and through stock protection against losses by contagious diseases, poisonous plants, and the depredations of wild animals, the work of past years was continued and extended.

Range management aims at maximum forage production, improved methods of utilizing the forage resource, and development of the stock industry along the lines most beneficial to the community. To secure from the range its largest economic returns to the stock industry in profits and to the country in meat supplies, wool, and hides, intensive methods of range utilization must be devised and adopted. Much of the foundation work for the development of such methods has now been done. With diminution both of the extent and of the carrying power of the open range, the problem of producing the beef and mutton which an increasing population must have has become serious. There is a growing tendency to remove stock from the unreserved lands to the forest ranges. The advance of settlement and the rapid appropriation of the choicest

lands and of areas which control large tracts of grazing land by individual stockmen is both diminishing the opportunity for new men to enter the stock business, and tending toward a situation in which the public will have to pay not only for the cost of production on the open range, but also for the charge which represents rising rental value. It is of no small consequence that so large a part of the range is in public control and may be used in the ways which will result in the greatest benefit to all the people.

#### ACQUISITION OF LANDS UNDER THE WEEKS LAW.

The work of examining lands for purchase by the National Forest Reservation Commission under the Weeks law was actively carried forward. During the year 665,000 acres were so examined, which, together with 175,000 acres examined in the fiscal year 1911, brings the total area thus far covered up to 840,000 acres. The total area in process of acquisition by purchase or condemnation at the close of the year was not quite 260,000 acres, situated in New Hampshire, Virginia, Tennessee, North Carolina, and Georgia. To prevent speculation in options it became necessary to announce during the year that no optioned lands would be considered for purchase. In order to secure title satisfactory to the United States it has proved necessary in many cases to resort to condemnation proceedings. Of the lands placed under purchase contract or condemnation proceedings during the year, part are cut over, part are more or less heavily culled, and part are virgin timberland. The prices paid ranged from \$1.15 to \$15 per acre, with an average of \$5.95.

#### STATE AND PRIVATE COOPERATION.

The first place in cooperative work with States is that provided for by the appropriation of \$200,000 carried by section 2 of the Weeks law, the aim of which is to secure the protection from fire of the watersheds of navigable streams. Cooperative agreements entered into with 12 States have resulted in the protection, wholly or in part, of such watersheds as the Penobscot, Kennebec, Connecticut, Merrimac, Hudson, Delaware, and Potomac in the Northeast, the Mississippi in Wisconsin and Minnesota, and the Columbia and Willamette in the Pacific Northwest. As a result of the law very great progress has been made by many States, particularly in the East, in the development of organized fire protection. There is great need for more work of this kind in the South, but few of the States there have as yet passed laws which make it possible, under the conditions which I have felt it necessary to prescribe, to enter into cooperative agreements with them. One very striking effect of the law has been to stimulate the proper care of forest resources

wherever its provisions have been applied. On the average every dollar expended by the Federal Government has resulted in the expenditure of at least \$2 by the State and private owner, and I look for this ratio to increase as the benefits of protection become clearly apparent. The sum appropriated will be exhausted by the year 1914. A further appropriation to permit this work to be continued and extended into new States is, in my judgment, highly desirable.

#### FOREST INVESTIGATIONS.

Experimental studies conducted on the National Forests, in addition to those having to do with reforestation, yielded results which will be of the greatest usefulness in arriving at the best methods of management and protection, and in determining forest influences, the characteristics of different forest types, and the growth, volume, and yield of important tree species. The utility of these studies is, in fact, twofold; for they not only furnish the necessary scientific basis for National Forest management, but also supply knowledge indispensable for the application of forestry to private timberlands throughout the West. The principal agency for conducting such investigations is the experiment headquarters which have been established on Forests affording conditions typical of a wide region, though the work is supplemented by field studies conducted in many different localities. Two new stations were established during the year. Though none of the stations has been established more than a few years, the results already secured have been of the greatest assistance in the actual work of forest management. Leading in the work of the past year were studies of the best silvicultural systems and degrees of cutting to secure natural reproduction; the effect of forest cover on streamflow, excessive wind movement, and evaporation; the damage caused by light surface fires; the deterioration of fire-killed timber; and the growth, yield, utilization, and life history of five important western trees.

Besides the investigations conducted on the National Forests, silvicultural and other studies were carried on to obtain information applicable to the best management of woodlands in all parts of the country. Aside from their use in the particular study for which they are gathered, the data and measurements collected in the course of silvicultural studies, taken together, furnish a basis upon which it is possible to establish laws and relationships of tree growth of the greatest value to those having to do with the study or management of timberlands. Dendrological investigations included studies of the distinguishing structural characteristics of important native trees and of foreign woods for which inferior substitutes are likely to be placed upon the American market.

Studies of forest products, centered mainly at the Forest Products Laboratory at Madison, Wis., yielded important results. These, by increasing our knowledge of the saving which can be effected by the preservation of wood against decay, by indicating the possibility of utilizing for different purposes supposedly inferior but abundant species in the place of more valuable ones now becoming scarce, and by showing how greater efficiency can be had in methods of manufacture, promote forest conservation in a very important field. Studies in wood preservation have dealt with the efficiency of various preservatives, the penetrability and resistance to decay of different woods, and the best methods of injection. Wood turpentine has been studied and analyzed to arrive at the best methods of distillation and refining and to determine how their composition is influenced by different methods of production. Woods heretofore utilized little or not at all in the manufacture of paper have been tried and found suitable for certain grades. Strength tests have been made on many species of American woods. Different methods of kiln-drying lumber have been studied, and a new and more efficient type of kiln designed.

#### BUREAU OF SOILS.

##### PROGRESS OF THE SOIL SURVEY.

The work of this bureau has been vigorously prosecuted during the last year. The soil-survey work has been carried on in 80 areas, distributed through 28 States.

There have been surveyed during the year 31,304 square miles, or 20,034,560 acres, on the detail scale of 1 mile to the inch, and 149,810 square miles, or 95,878,400 acres, on the reconnoissance scale of 4 miles to the inch. The reconnoissance work has been mainly in the Great Plains region.

More and more active interest is being taken in the soil survey, and a number of the States, in addition to those which were reported last year, have started active cooperation work with the bureau, in order that the progress of the survey within their borders may be hastened for the benefit of their people.

The soil-survey work as a whole has progressed to such an extent that a very fair idea can now be drawn of the soil resources of the country, and the results are being used extensively as the basis for other lines of agricultural investigation and for the development of agricultural possibilities and resources.

During the year a revision of all the work completed to January 1, 1912, has been made. The material is at hand for a comprehensive bulletin on the soils of the United States, showing the meth-

ods used in the soil survey, the basis of the classification of the soils, and the use to which each of the soil types is best adapted.

At the same time active work is being prosecuted in the further study of some of the individual soil types and soil series that are of great national importance and in the preparation of reports giving a comprehensive view of the uses to which they are now put, and suggesting their best use in different parts of the country and under different climatic and industrial conditions. A bulletin describing the Norfolk series has already been prepared, covering the whole question of the best use of these several soils in the important special line of truck farming. A similar bulletin on the Clyde soils, typically developed around the Great Lakes, is in progress, and some preliminary work has been done on some of the other important soil series.

The reconnoissance surveys have been extended in the Great Plains, until now soil maps have been published or are in course of publication of the western half of two-thirds of North Dakota, South Dakota, Nebraska, Kansas, the Panhandle of Texas, and a large area in south Texas, giving an almost continuous strip from Canada to Mexico.

While these maps are on a scale of 4 miles to the inch, it is believed that for many years to come they will serve the purpose of aiding in the agricultural development in this sparsely settled region, where the soils are uniform over large areas and where for this reason greater detail of mapping is not absolutely essential.

Several of the most experienced men in the soil-survey work have been detailed to assist the Bureau of Forestry in the examination of the soils of the National Forests and to pass upon their agricultural value for the information and guidance of the Forest Service in carrying out the law regarding the elimination of agricultural lands from forest reserves. As this work must develop to large proportions in the immediate future, I have included in my estimates an increase of \$20,000 for the Bureau of Soils. Only in this way may the bureau meet the increasing demands that will result from the requirements of the last appropriation act for this department.

#### SOIL CHEMISTRY.

Work has continued during the year on the fundamental and thorough investigation of the composition of important soil types, determining both the mineral components of the soil and all of the elements, including the rare elements that have heretofore been overlooked in the chemical analysis of soils, for the purpose of throwing more light than has heretofore been shed upon fundamental differences or similarities between the mineral parts of soils.

## SOIL PHYSICS.

The physical properties of soils have long been recognized as exceedingly important in the distribution of crops and in the development of agriculture.

The relative amount of sand, silt, and clay and the way these are combined or held together has an important influence on the drainage and aeration and on the mechanical work of cultivation, and with the organic content of soils has a very important influence on the retentive power of the soil for moisture and the supply of moisture available for crops. The extent to which these physical properties can be influenced by cultivation, fertilization, and by crops themselves is being investigated as a basis for improved and efficient methods of maintaining the soil in suitable physical condition for those proper functions that are adapted to the needs of our staple or special crops.

## FERTILIZER INVESTIGATIONS.

The investigations along this line have shown that the United States contains ample raw materials for the production of all the standard fertilizing materials that it now demands.

The groves of giant kelp along the Pacific coast of Mexico, the United States, and Alaska have been found to contain a vast supply of potash salts which can be recovered for agricultural use; and if these kelps are properly protected and the plants are allowed to grow and function normally, the segregation of potash salts from the sea water continues and, by harvesting from time to time, a continual supply of potash can be maintained.

The mechanical difficulties in the cutting and harvesting of the material are now being taken up by commercial firms in a way that makes it seem probable that adequate methods may be devised to utilize this source for the production of sufficient potash for the country's needs.

In the meantime, an unremitting search has been maintained for possible surface deposits of potash salts in some of the desert basins. Theoretically, it seems probable that areas may be discovered where segregation of these salts has occurred, and one such deposit, rich in potash, is now actually being exploited commercially. This is especially important since the examinations that have been made of our salt brines seem to show that there is little prospect of success along this line.

The enormous deposits of phosphate rock in this country have a tendency to induce waste and undue exploitation of high-grade rock only. From investigations now well advanced, however, it appears



that at no distant time the utilization of low-grade rock may be looked for on a commercial scale.

The investigations into the possible sources of supply of nitrogen have been sufficient to indicate that if future developments make it necessary the United States can supply its requirements of this expensive material.

#### SOIL-WATER INVESTIGATIONS.

In my first report to the President, made nearly 16 years ago, I called attention to the fact that rainfall was of little benefit to crops until it had entered the soil, and from there on the benefit was proportional to the ability of the soil to retard and regulate its flow toward the sea. The whole question, therefore, of the utilization of the rainfall in agriculture depends first upon the amount of water which enters the soil and next upon its movement within the soil.

During the last year a very exhaustive study has been made of the depth of free-flowing ground water under the surface of the soil in all parts of the United States, and somewhat as to the movement of this ground water, which has been found in some instances to extend over hundreds of miles between the source of supply and the discharge into the sea.

Having determined the fundamental position of the free water in the soil, it remains to study more intensively than has been possible heretofore the distribution of the water between the ground water and the surface of the land, as well as the effect of cultural methods in properly regulating the supply available for crops. It is believed that methods are now available by which this important but very intricate problem can be worked out.

#### SOIL-FERTILITY INVESTIGATIONS.

Thirty-five to forty definite organic chemical compounds have been separated from the humus portion of the soil, and a number of these were discovered in the last year.

Sufficient is known of the subject now to indicate that the soil has certain functional activities and that organic matter is digested in the soil, through the agencies of bacteria, enzymes, fungi, insects, and more purely chemical agencies in a manner similar to the processes of digestion in living organisms. The presence of certain organic bodies in the soil indicates that the functional activities of the soil are proceeding in such a way as to make the conditions beneficial or harmful for any particular plant or crop.

It has been found, furthermore, that through methods of cultivation, of fertilization, and of crop rotation the functional activities of the soil may be controlled within limits so as to put the soil in

better condition for crops than it formerly was, or to maintain it in such conditions of functional activity as to exact from the soil a larger crop and a better condition in the soil for succeeding crops.

The problem of soil fertility is thus shown to be exceedingly complex, but its very complexity makes it appear hopeful that we will ultimately reach the understanding of the subject that will enable us to handle intelligently all our important soil types and so to understand their peculiarities and their particular needs as to enable the most rapid progress in the development of more intensive methods of agriculture than now prevail.

#### BUREAU OF ENTOMOLOGY.

Without increased appropriations by Congress, the work of this bureau has been carried on during the year along much the same lines as indicated in previous reports, and with a continually increased benefit to the agricultural interests of the country. While its efforts have been directed mainly to the search for the best methods to control the insect enemies of agriculture and horticulture, the subject of the damage to the health of live stock and to the health of man himself by the carriage of disease by insects and the subject of the insect injuries to forests have been included in the work of the bureau.

#### THE GIPSY MOTH AND THE BROWN-TAIL MOTH.

There was during the year comparatively slight increase in the territory infested by gipsy and brown-tail moths. The work of attempting to prevent the further spread has been continued in the way of clearing up roadsides, in the way of the inspection of all plants and plant products going out of the infested territory, by the study of the diseases of the gipsy moth, and by the continued importation and establishment of parasites and natural enemies of both species from abroad. Conditions within the infested territory continue to improve, and neither the gipsy moth nor the brown-tail moth is any longer the pest in the villages and towns of New England that it was even five years ago. In the woodlands the damage produced especially by the gipsy moth is still evident, but great progress has been made in the study of woodland conditions, and this study has apparently arrived at the point where the preservation of the forest areas in New England seems to be a decided possibility, even in the presence of the gipsy moth, and this may be brought about by a varied system of forest management, the details of which are being prepared for publication and general distribution. But one new isolated outbreak of the gipsy moth of any size was discovered during the year, and this was found at Geneva, N. Y. The State authorities, aided by the advice of the experts of the bureau, have appar-

ently radically exterminated the insect at this point, so that there is no fear of future spread from this portion of central New York.

#### THE ALFALFA WEEVIL.

Active work against the alfalfa weevil, which threatens widespread destruction, has been carried on with the help of added funds appropriated by Congress. More men have been added to the field force, and the insect has been carefully followed through the entire year. Not only has this work been carried on in the laboratory and in the fields adjoining the headquarters, which are at Murray, Utah, but it has been duplicated to a large extent in higher altitudes in order to obtain thorough knowledge of the insect throughout the territory over which it has become distributed. Experimental work with parasitic insects and parasitic fungi has been carried on, and several species of parasites have been imported from Europe, which is the original home of this weevil. Field experiments looking toward the combining of alfalfa with other crops, in order to reduce the intensity of the weevil attack, have been carried on in cooperation with the Bureau of Plant Industry, and mechanical field experiments have been made upon a large scale. It seems now that the second and third crops of alfalfa can be grown successfully, even in the presence of the weevil, by adopting measures discovered in the course of this work, but, as the important crop is the first crop, more work remains to be done in the hope of discovering methods of obviating or greatly reducing the attack of the weevil in the early portion of the year. The insect does not seem to have spread as rapidly as was feared, but it is likely to turn up at almost any point where alfalfa is extensively grown.

#### WORK AGAINST FOREST INSECTS.

It is a pleasure to announce, in connection with the work against forest insects, that while a year ago great damage was threatened by the southern pine beetle in the States of North Carolina, South Carolina, Georgia, Florida, Alabama, Mississippi, Louisiana, and Texas, the efforts made by the bureau resulted in such good work on the part of timber owners that the danger mark may be said to have been already passed for the present and that the enormous prospective damage has been prevented. In the course of this work there was one notable example of successful control at direct expense. In a 90,000-acre tract, where there was thousands of dollars' worth of beetle-killed timber and every indication that the damage would be even greater this past year, \$373 were spent in the cutting and burning of 60 infested patches, with the result that in the spring of 1912 it was found that the spread of the insect had been practically checked and that almost no pine was being attacked.

Work of this same character has been carried on at a number of points in the West by cooperation with the State authorities, with the Forest Service of this department, and with private owners, and it has been demonstrated again and again not only that much of the loss of insect-killed timber in past years might have been prevented without any extra expenditure of funds, but also that with care and foresight in the future the work of the destructive bark beetles over nearly all of our territory can be economically controlled.

#### INSPECTION WORK.

I called attention in my last two annual reports to the urgent need of the passage by Congress of a plant quarantine and inspection law, showing as forcibly as possible that the United States has been the only great power without a law to protect it from insect pests and plant diseases from other countries with which it has commercial relations. Down to the close of the past fiscal year, although legislation was pending in Congress, no action had been taken, and with a view to securing as perfect inspection as possible in the countries of origin of nursery stock especially, which was bound to be imported in large quantities the coming autumn into this country from portions of Europe, the chief of the bureau was sent abroad to confer with the nurserymen and the inspection officials of those countries. Toward the close of the session of Congress within the present fiscal year, an inspection and quarantine bill was passed by Congress and a Federal Horticultural Board was established, composed of members of the Bureau of Entomology, of the Bureau of Plant Industry, and of the Forest Service. Regulations have been drawn up by this board covering the importation of products likely to carry injurious insects and disease, and certain quarantines against certain classes of products have been announced. This is a great step in advance, and it is hoped and expected that the operations of the act will serve as a marked protection against the introduction of injurious species into this country in the future. When we consider that more than one-half of the pests of this kind of first-class importance existing in this country have been in past years introduced in this way and unwittingly established in our midst, with the resultant damage of millions of dollars' worth of property, the country can at last congratulate itself upon the fact that it is in position to prevent very great prospective waste.

Inasmuch as special mention was made in a previous report of the destruction by experts of this bureau, after inspection, of a large shipment of ornamental flowering cherry trees sent as a gift from the city of Tokyo to the wife of the President, it is a pleasure to announce that among the importations of the past year which have

been inspected here in Washington there was another shipment of 3,000 ornamental flowering cherry trees sent by the city of Tokyo to replace the former shipment, and that after inspection these trees were found to be free from injurious insects, although examined individually with great care. They have been planted in the District of Columbia.

#### WORK ON INSECTS AFFECTING THE HEALTH OF MAN.

The investigation carried on by the Bureau of Entomology on the Rocky Mountain fever tick was completed during the year and the results published. The investigation showed that the proper treatment of certain domestic animals will probably result in the practical extermination of this disease in the infected regions.

A very interesting investigation has been begun concerning the possible relations of biting insects to the carriage of pellagra. These investigations have been carried on for the most part in the State of South Carolina in cooperation with the Postgraduate Medical School of New York City. It is well known that claims have been made by an English investigator, Sambon, working in Italy, to the effect that pellagra in that country is probably carried by the bite of a gnat of the genus *Simulium* flying from patients affected by the disease to healthy persons. The investigations which have been carried on in South Carolina, however, seem to indicate that, in this country at least, if pellagra should be shown to be carried by any biting insect, the insect concerned in this transmission in South Carolina is very much more probably the biting stable fly or biting house fly (*Stomoxys calcitrans*) than any of the resident species of the genus *Simulium*. This conclusion is especially significant in view of the recent announcement by the experts of the Harvard Medical College that they have secured experimental proof of the transfer of infantile paralysis by this same species.

#### WORK ON THE WHITE FLY IN FLORIDA AND ON OTHER ORANGE INSECTS.

The investigation of the white fly in Florida has made substantial progress and is nearing completion. The parasites imported from India have apparently died and have not become established in Florida, but inexpensive and effective methods of spraying have been found and are now being used and promise to settle in a satisfactory manner the problem of direct control. Demonstration work is now going on.

Work on the orange thrips being carried on in California has resulted in the finding of satisfactory spraying methods, and, after demonstration on a large scale, these methods have been adopted by the orange growers.

Further investigations have been begun with a view of still further cheapening the hydrocyanic-acid gas process for the fumigation of orange trees against scale insects in southern California. The results previously announced have brought about enormous economy in these methods, and work going on at the present time promises to cheapen them still further to a degree which will result in very great benefit to the growers.

#### OTHER WORK.

The Mexican cotton boll weevil has continued to spread somewhat, and has reached western Florida. Owing to the early cold weather of the autumn of 1911, certain territory in the northern range of this species was at least temporarily rid of the pest, the early freeze catching them in the larval condition. Work on the testing of control measures has been carried on in the Mississippi Yazoo delta, and the study of the parasites of the species has been continued, while attempts have been made to locally concentrate parasites from one region into another.

Work upon tobacco insects and the insects affecting sugar cane has been continued. An extensive experiment has been carried on in New Orleans in the effort to eradicate totally the sugar-cane borer which bids fair to be successful in this locality.

The Argentine ant has been shown to be most injurious to orange plantations in Louisiana and now threatens to spread to the orange groves of Florida. Measures of control so far ascertained have been reasonably successful, but it is difficult to secure their general adoption.

The work on the cotton red spider in South Carolina has indicated the food plants upon which this creature passes the winter, and a spray of potassium sulphide in water has been shown to be an economical and effective method of destroying the spider when it has invaded a field. Work with this solution can be successfully carried on at an expense of 75 cents per acre.

Large-scale spraying operations against the pear thrips have been carried on as demonstrations in California. Nearly 15,000 acres of orchards have been sprayed under the direct supervision of the bureau and with excellent results.

Field work against the onion thrips has been continued in Texas and Indiana. Good control measures have been discovered against this insect, and with widespread cooperation it is believed that the damage which it does may be largely stopped.

#### THE MEDITERRANEAN FRUIT FLY.

The appearance in destructive numbers of the so-called Mediterranean fruit fly in the Hawaiian Islands attracted much attention, especially from the State of California, since it was feared that the

introduction of this pest from Hawaii into the port of San Francisco would result in serious damage to the fruit crops of the Pacific coast. Funds would not permit of active operations on the part of the department against this pest prior to the close of the fiscal year, but preliminary studies were made in anticipation of an appropriation by Congress, which was granted toward the close of the session in August. The results of the work done under this appropriation will be reported next year, but it should be stated at this time that experts have been sent to Hawaii and that all aspects of the threatened danger which seemed to afford a profitable field for investigation are now being carefully studied by competent men, while, with the cooperation of the Territorial government and of the State of California, actual exterminative work in the region of Honolulu is being carried on as far as possible.

#### BUREAU OF BIOLOGICAL SURVEY.

##### REARING FUR BEARERS.

There are extensive regions in the United States well adapted to fox farming and kindred industries, and the rearing of fur-bearing animals for their pelts continues to be a subject of much interest, as is shown by the many inquiries from various parts of the country asking for information on the subject. Skunks, muskrats, mink, and foxes are reared in captivity or on preserves under control of breeders. The great demand for breeding animals and the reluctance with which successful breeders part with their stock of black foxes have caused large prices to be asked for mature animals, preventing the business from becoming general, and confining the industry in the hands of a very few.

Comparatively few attempts to raise mink have been made in the United States, and but little is known on the subject. But at from \$3 to \$8 for first-class pelts, the present prices, which are not likely to diminish, the raising of these animals should be remunerative, especially in connection with some other established business, such as poultry raising, orcharding, or truck growing; therefore, in cooperation with the National Zoological Park, steps have been taken to experiment with these animals with a view to determining the most successful methods of rearing them.

Muskrat farming is already a prosperous business, and has probably reached its highest point of development on the Eastern Shore of Maryland, although followed in other sections of the country. Muskrat marshes are worth more, measured by the actual income from them, than cultivated farms of like acreage in the same vicinity. The marshes need only to be protected from poaching, as the muskrats feed on the roots of the reeds and marsh grass, and the

rental to the trappers is usually for half the fur, leaving the meat as an additional source of gain to them. Only one other animal in the world, the European rabbit, exceeds the muskrat in the number of skins marketed.

#### RODENTS IN RELATION TO AGRICULTURE.

Prairie dogs, ground squirrels, and gophers are very destructive rodents, inflicting large damage and levying a heavy tax upon the tillers of the soil; therefore the Biological Survey conducts experiments with poison baits, traps, and other methods of extermination.

The daily forage consumed by 32 adult prairie dogs equals the amount required by a sheep, and 250 eat approximately as much as a cow. The ground squirrel, though smaller, is a voracious feeder, and the gophers, comparatively small, are not abstemious. As the region infested by these pests includes a number of Rocky Mountain States, California, and other Western States, and as some of the colonies occupy many thousand acres and aggregate millions of rodents, the extent of the damage they do to forage and other farm crops can be readily comprehended.

Besides, it has been definitely ascertained by the investigations of the past two years that the spotted-fever ticks, in the two younger stages, live almost wholly on small native rodents, and that the California ground squirrel has been infected with bubonic plague by fleas from rats, hence that these dread diseases are likely to become endemic. Therefore there are two important reasons for attempting the extermination of the animals. The chief reliance for this is placed on the use of poisoned grain and other poisoned baits, but the use of traps, and, in some cases, the use of carbon bisulphid or pintsch oil in the burrows, supplements the poison. In these experiments oats have been found to be the best vehicle for carrying poison, as it is readily eaten by the rodents and rarely by birds.

#### THE ECONOMIC RELATIONS OF BIRDS TO FARMING.

Investigations by the bureau, in cooperation with the Bureau of Entomology, as to the relations of birds to the insect to determine what aid, if any, birds are likely to lend in checking the increase of the alfalfa weevil and retarding its spread, show that although the weevil has been established in this country only five or six years 31 species of birds have already learned to eat it. It is an interesting discovery that the English sparrow heads the list as a determined foe of the weevil, and that, if it is possible to utilize the services of the English sparrow against the formidable insect foe, the alfalfa weevil, it will be part compensation for the damage done by that bird in other sections.



Birds also prey upon the boll weevil while it is hibernating, while on the cotton plants, and during its autumnal migration flights—the period when the weevil chiefly extends its range.

The Biological Survey, by making a careful analysis of the stomach contents of different species of birds, can show their relation to agriculture and horticulture, whether beneficial or injurious, and approximate the good or harm they do. The importance of this work is very great.

A Farmers' Bulletin entitled "Some Common Birds in Relation to Agriculture," which was issued many years ago, has always been in great demand, and over 500,000 copies have been distributed. In order to furnish additional literature along the same lines, two other Farmers' Bulletins on familiar species of birds have been prepared, one dealing with some common game, aquatic, and rapacious birds in relation to man, and the other treating of the common birds of forest, field, and garden.

#### IMPORTATIONS.

In addition to studies of native birds with the view of aiding the farmer, supervision of the importation of birds and animals in order to prevent the introduction of species which might prove injurious is by law maintained by the bureau, and 583 permits were issued and 140 consignments inspected by the regular inspectors of the Biological Survey stationed at New York, Philadelphia, and San Francisco, as compared with 519 permits and 123 inspections in 1911. Under these permits there have been imported 428,269 birds and 4,582 mammals. Of these birds there were 338,275 canaries, 15,409 pheasants, 23,181 partridges, 11,353 miscellaneous game birds, and 40,051 miscellaneous nongame birds. Besides these, 28,808 birds and 875 mammals requiring no permits were admitted to entry, making a total of 457,077 birds (including 362,604 canaries, 15,412 pheasants, 23,181 partridges, 11,493 miscellaneous game birds, 44,387 nongame birds) and 5,457 mammals. Fifty-five permits were issued at Honolulu covering the entry of 123 birds, 17 mammals, and 10 reptiles.

Among the birds were 23,181 European partridges, as compared with 36,507 in 1911. This bird has not proved as popular as it did several years ago, and has been purchased in smaller numbers by State commissions and private individuals. The importation of quail from Mexico reached 7,570, as compared with 3,110 in 1911 and 1,246 in 1910. This number might have been much larger but for the suspension in the issue of permits early in February, owing to an outbreak of the highly infectious quail disease in the Southwest and the practical cessation of all interstate shipments of quail after that date. Among the rarer waterfowl were some 250 Formosan teal. These birds were first imported into the United States in 1909, but

the number brought in during the past fiscal year considerably exceeds that of preceding years. Interesting, also, was a shipment of 16 California Valley quail, imported from Austria. These birds, like wood ducks and other native species, have been sent abroad, where they are raised in captivity and are now being reimported.

Among the miscellaneous nongame birds was one Imperial Amazon parrot, imported from Dominica for the New York Zoological Park. This very rare parrot is almost extinct, and the specimen, which arrived on February 19, 1912, is apparently the first that has been imported alive into the United States. The shama thrush continues in popularity as a substitute for the mocking bird, as shown by the fact that more than 200 were brought in during the year. Rare birds imported for the first time included several East Indian species, most of which were consigned to the New York Zoological Park. Among the rarer mammals was a female gorilla, received by the park on September 23, 1911, which only lived until October 5. By far the larger number of mammals were guinea pigs and monkeys, imported for laboratory and pathological experiments. About half the squirrels imported are the European red squirrel, and the remainder are chiefly Mexican species. There were also about 1,300 white mice, intended chiefly for research purposes, a few silver and cross foxes, several beavers, and a number of ferrets. The foxes and beavers come from Canada, the former imported for breeding purposes, the latter for exhibition, while the ferrets are imported chiefly for killing rats.

No prohibited species, so far as known, have gained entry during the year. Under date of July 10, 1911, the director of the New York Zoological Park ordered the destruction of the female mongooses belonging to the park, leaving three males. One of the latter died in March, and on June 2, 1912, the other two were still on exhibition.

#### NATIONAL GAME AND BIRD RESERVATIONS.

It is not too strong an assertion to say that the antelope is in greater danger of extermination than any other kind of American big game, and that serious consideration and well-directed effort are necessary to prevent the species from becoming extinct in several States in which it was formerly abundant. The Yellowstone Park does not contain half as many antelope as it did four years ago, and not a national game refuge has been established in a region where antelope still remain, while attempts to stock certain bison ranges with those animals have not as yet met with success. There is great need for a suitable preserve, especially for antelope, in the antelope country. More effective protection seems to have been provided on private ranges in the Southwest than under either Federal or State auspices.

The work of caring for elk in Jackson Hole was continued during the winter in cooperation with the State authorities, and efforts will be made to place the winter feeding of elk at that point upon a more permanent basis by the acquisition of a refuge where hay can be produced and fed. It is estimated that 7,250 elk were fed last winter, but this is less than half of the 17,160 estimated to have wintered in that region. Adding these to the more than 30,000 which wintered in the northern part of Yellowstone Park, it shows that the great herds in the park and its vicinity number less than 50,000.

With the 10 calves born this spring, the buffalo on the National Bison Range have now increased to 81, or 44 more than the original number placed there three years ago. The beaver having disappeared from Mission Creek, arrangements have been made to procure fresh stock from the Yellowstone Park, and there are now several elk and some antelope on the range.

The national bird reservations number 56, including the Pribilof Reservation in charge of the Department of Commerce and Labor and the four new ones created during the year at Forrester Island and Hazy Islands, Alaska, Niobrara, Nebr., and Green Bay, Wis. For the better organization of the administration of these, four inspectors were appointed—one for the reservations in Oregon, one for the coast reservations in Washington, one for the mountain district, and one for the Florida reservations in the Gulf district. An additional warden was appointed for Clear Lake Reservation, Cal., and a special agent detailed to inspect the reservation at Bellefourche, S. Dak., Carlsbad, N. Mex., the southern reservations of Florida, and Forrester Island, Alaska. No species has ever been introduced on any of the bird reservations, with the exception of the European rabbit on Farallon Islands, Cal., and Laysan Island, Hawaii. In both cases they have increased so enormously that they have already become a serious pest, and efforts will be made to reduce them on Laysan Island. As in former years, permits have been issued to trap on two of the Oregon reservations, and 4,858 muskrats, 190 minks, 13 skunks, 11 weasels, 12 raccoons, 3 otters, and 21 coyotes were taken. The severe storms destroyed many nests, eggs, and young birds on the Passage, Key, and Pelican Island Reservations, but information received in the spring indicated that they had recovered from their losses.

Every effort has been made to stop the sale of plumage of certain birds, particularly herons, which in recent years have been slaughtered for the millinery trade. Laysan Island has recovered somewhat from the devastation wrought by plume hunters in 1910, but the colonies are still in a sadly reduced condition. Through the cooperation of the Revenue-Cutter Service, the *Thetis* visited the island twice during the year and reported everything in good condition.

Semiannual visits by cutters of this service will prevent molestation of the birds, as poaching will thus be made unprofitable.

#### GAME PROTECTION IN ALASKA.

At the close of the fiscal year new regulations were issued under the Alaská game law to afford additional protection to deer, prevent the excessive traffic in moose on the Kenai Peninsula, and to suspend deer hunting on five islands in southeastern Alaska, thus practically making them game refuges. The suspension of the sale of venison in 1911 has been continued through the season of 1912. Through cooperation of the Secretary of the Treasury, special instructions were given to the revenue cutters patrolling Bering Sea to insure a strict enforcement of the law protecting walrus.

Under the appropriation of \$15,000 for the protection of game, wardens appointed by the governor were stationed at several of the more important points. Sixteen permits were issued for the collection of specimens for scientific purposes or for exhibition.

#### INFORMATION CONCERNING GAME.

Through cooperation with the Forest Service, comprehensive data were collected for the first time regarding the number of big game animals killed on the various national forests, and as these forests include the principal hunting districts in the Western States the data thus collected furnish a practically complete basis for estimating the total number of big game killed in several of the Western States.

The index of game legislation has been almost completed. During the year the laws of Maine, Massachusetts, New Hampshire, Rhode Island, Connecticut, Pennsylvania, and most of those of New York were indexed. At the present time the only gaps in the index are a few years in New York, Maryland, and North Carolina. The work had advanced to a point early in the year which warranted the publication of a summary of some of the more important provisions under the title "Chronology and Index of American Game Protection from 1776 to 1911."

Data on the protection of migratory birds have been summarized, and likewise information brought down to date on the subjects of hunting licenses, National and State game preserves, bag limits, game commissions, and similar topics concerning which frequent requests for information are received. As in several previous years, data concerning the number and details of fatal hunting accidents were collected. These data show a regular increase in the number of fatalities in the United States from year to year, but it is believed that a certain proportion of these accidents can be obviated by special legislation.

The usual annual game publications were issued, including the "Directory of Game Officials," "Summary of the Game Laws for 1911," and posters showing the open seasons for game.

#### DIVISION OF ACCOUNTS AND DISBURSEMENTS.

During the year there were received, audited, and paid 129,584 accounts, amounting to \$16,032,446.08. More than 5,000 of these accounts, moreover, were so-called combined accounts, in connection with which there was probably a saving of at least 25,000 checks, to say nothing of the saving of other clerical labor. There were also audited and sent to the Treasury for payment 6,241 accounts. In the payment of the 129,584 accounts mentioned above it was necessary to draw 212 requisitions on the Treasury and issue 241,544 checks. There were issued during the year 30,940 purchase orders for supplies, 6,683 letters of authorization for travel, 47,225 requests for passenger travel, and 11,105 requests for department bills of lading and requests on the Quartermaster General for the transportation of Government property, while about 187,600 letters were written or received in the ordinary transaction of business.

To carry on the work of the Department of Agriculture during the fiscal year ended June 30, 1912, Congress appropriated \$16,900,016 for the ordinary expenses of the department, in addition to which permanent annual appropriations and special appropriations amounting to \$6,190,826.15 were available, making a total of \$23,090,842.15.

The disbursements of the department to June 30, 1912, pertaining to the fiscal year 1912 amounted to \$17,772,993.80, and the greater part of the balance of \$5,317,848.35 will be required for the settlement of outstanding liabilities.

The amount for rent of buildings in the District of Columbia for the several branches of the department was \$71,804.75, and all accounts for the fiscal year 1910 having been settled, the unexpended balance of appropriations for that year, amounting to \$344,760.56, was covered into the Treasury on June 30, 1912. The account for the fiscal year 1911 is still open.

The amount estimated for the fiscal year 1914 in the annual estimates for the regular appropriation bill is \$18,287,230, which includes \$1,440,000 for agricultural experiment stations, an increase of \$1,635,734 over the appropriation bill for the fiscal year 1913. In addition to this, there will be available permanent annual appropriations amounting to \$5,689,200, making a total of \$23,976,430.

There is also an estimate in the sundry civil bill for printing and binding for this department amounting to \$512,500, making a grant total of \$24,488,930. The increase requested in the regular appropriation bill will be used principally in the extension of the

activities of the department in connection with the eradication of tuberculosis among domestic animals, the eradication of cattle ticks, research work now under way on various dairy problems, the prevention of the introduction into the United States and the manufacture and sale therein of dangerous or worthless serums and viruses for use in the treatment of domestic animals, grain standardization and general cereal investigations, farm-management investigations, farmers' cooperative demonstrations, the classification of agricultural lands, investigations in agricultural chemistry, the enforcement of the food and drugs act, meat inspection, the determination of sources of supply of nitrates and other fertilizer materials in the United States, soil survey, entomological and biological studies and investigations, farmers' institutes, irrigation investigations, investigations of systems of road management and best methods of road making and maintenance, field experiments with road-making materials, and the enforcement of the insecticide act and the plant quarantine act.

#### DIVISION OF PUBLICATIONS.

The results of the experiments, investigations, and activities of the department are made available for the information and guidance of the people by means of its publications.

By the most careful economy it was possible to issue 24,900,557 copies of 1,462 new pamphlets, containing 32,842 printed pages and 3,518 illustrations, and 9,778,000 copies of 648 reprinted documents, containing 23,179 pages and 3,977 illustrations. Therefore the total publications handled in this office amounted to 2,110 separate pamphlets, containing 56,021 pages and 7,499 illustrations, and aggregating 34,678,557 copies. Of these 20,998,557 were miscellaneous publications, 10,409,000 were Farmers' Bulletins, and 3,271,000 were lists of available Farmers' Bulletins. That so many new publications were issued and so great a number distributed is due to the economical and efficient supervision of the printing fund by the Division of Publications.

#### NO PUBLICATIONS WASTED.

The fact of greatest interest in connection with this large volume of publications is that they were all distributed to people who asked for them, and that many more could have been sent out if we had been able to fully supply the demand, which came from every section of the country. No one who applied has failed to receive at least some of the publications he wanted if they were available. It has been the policy to supply some publications to every applicant rather than a large number to a few persons, and with the exercise of discretion in the distribution of the publications none have been wasted.

On account of the great activity of the department's investigators and the unprecedented demand for published results, the appropriation for printing and binding was practically exhausted early in June, in consequence of which numerous publications containing accounts of the results of important investigations were delayed until July 1, to the great inconvenience of the department and the disappointment and loss of the public. An increase in the appropriation is necessary in order to enable the department to publish all the information acquired for the benefit of the people, as required by the organic act creating the department.

#### FARMERS' BULLETINS.

The demand for Farmers' Bulletins has never been so great. This is not surprising, since they are written in plain language and cover such a variety of subjects, among which are some sure to be of interest to everyone. Forty-four new bulletins of this series were issued during the year. It is now 23 years since the first Farmers' Bulletin was issued, and the unfailing popularity of these pamphlets has demonstrated the wisdom of their publication. In 1896 less than 2,000,000 met the demand, while in 1912 nearly 11,000,000 copies were issued, and many more were requested by correspondents, but could not be supplied. These bulletins are distributed jointly by the department and Members of the two Houses of Congress, four-fifths being placed at the disposal of Senators, Representatives, and Delegates. With the present appropriation it is possible to make an allotment of 12,500 copies to each, which is admittedly insufficient to supply the requests. With the increased membership of the Sixty-third Congress an increase of 10 per cent in the present appropriation of \$125,000 will be required to allot this number to each Senator, Representative, and Delegate, and I have accordingly submitted an estimate for \$137,500 for the printing of these publications. Of these publications 7,351,262 copies were distributed upon the orders of Senators and Representatives, being 1,877,183 more than during the last year.

#### SALE OF DEPARTMENT PUBLICATIONS.

The superintendent of documents of the Government Printing Office is authorized by law to sell Government publications, and, with the consent of the head of the department, to reprint such as may be needed to meet the demands when his supply is exhausted, defraying the cost out of his receipts for publications sold.

Last year he sold 171,866 copies of this department's publications, 120,450 of which were provided from reprints. The amount of these sales was \$16,428.07. The larger number of the publications sold

were from the technical and scientific series, and of course much the greater part of the receipts was from the sale of that class, but there was an increase in the number of popular pamphlets called for, showing the willingness of the unscientific reader of agricultural literature to pay the nominal price charged when the department's supply is exhausted.

#### LARGER EDITIONS OF 100-PAGE PUBLICATIONS.

In my last report reference was made to a provision of a bill revising the general printing law pending in Congress increasing the limit on editions of bulletins of the department from 1,000 to 2,500 copies. The bill is still pending, and it is earnestly hoped that this provision will be retained, in order that the department may distribute its more important publications, in many cases of high scientific value, more widely among the colleges, universities, and investigators in the scientific world, instead of being limited to Government institutions, and most of these only in this country. There are numerous other equally important provisions in the new printing bill which if enacted will enable this department to administer its appropriation more economically and efficiently and increase its usefulness to the people.

#### EDUCATIONAL USE OF OUR PUBLICATIONS.

The demand from the instructors and pupils in all grades of schools for agricultural literature is evidenced by the numerous requests, frequently for large numbers, received for department documents, which, owing to limited funds, it has not been possible to grant. Many of our publications are being used as textbooks, and it is believed that such use should be encouraged, even at the expense of an increase in the fund for printing.

#### SCIENTIFIC AND TECHNICAL PUBLICATIONS.

The publications of a scientific or technical character constitute about 35 per cent of those issued by the department, and while their distribution is naturally rather restricted, they constitute the permanent record of the achievements of our scientists, and many of them furnish the basis for the numerous popular bulletins and reports. They are of the greatest importance, and their prompt publication should always be insured. This has not always been possible with the available funds, and an increase in the appropriation has been requested and should receive favorable consideration. The issuance of a monthly or quarterly serial to which all bureaus, divisions, and offices could contribute would afford a convenient and permanent record for publishing many brief scientific papers which separately



are too small to print, but which contain valuable results which should be published rather than preserved only in manuscripts, as at present.

#### ILLUSTRATIVE WORK.

Aside from the illustrations for publications, much of the work comprised diagrams, photographs, slides, etc., for the use of department experts in connection with lectures which they are called upon to deliver before agricultural organizations and societies in many parts of the country, showing the work of the department. This is one way of taking the department to the farmer.

The increasing use by the press of extracts from our publications is most gratifying, supplementing the wide distribution already given them by the department.

In every branch of the department's publication work, comprising editing, indexing, illustrating, and finally, the distribution of the publications, the results achieved exceeded those of any other year.

#### BUREAU OF STATISTICS.

The primary duty of the Bureau of Statistics is the preparation of monthly reports giving seasonable information concerning the acreage planted to the principal crops of the United States, their condition from month to month during the growing season, and their yield per acre, total yield, and quality; also the condition from month to month and relative production, expressed in percentages of full production of minor crops.

The number, value of farm animals, stocks of grains in the hands of farmers at specific dates, and the average prices received by farmers for leading products each month are reported; and a few other miscellaneous subjects, such as causes of crop damage, movement of crops, cost of transportation, farm wages, and the progress of spring plowing and planting, are dealt with.

#### SOURCES OF INFORMATION.

These reports are based on statements made by voluntary correspondents and salaried employees located throughout the agricultural sections of the country, in reply to inquiries prepared in the bureau and sent out from Washington embracing the subjects dealt with each month.

The voluntary correspondents are public-spirited citizens rendering service without compensation, and are excellent farmers, as careless or indifferent farmers will not take the pains to report month after

month and year after year without money compensation; and some of these men have served the department 36 years. These voluntary correspondents, numbering about 130,000, consist of township correspondents, reporting for the townships in which they reside; county correspondents, reporting for the county in which they reside, from personal knowledge and upon two or more reports made by assistants living in other parts of the county; and special correspondents, supplying special information, such as crop yields, farm prices, cotton acreage and ginning, concerning grain in mills and elevators, the live stock on farms, and the tobacco industry.

The salaried reporters are State statistical agents, one residing in each State and rendering monthly reports to the bureau based on reports received by him from correspondents throughout the State and on his own personal knowledge and observation, and the special field agents assigned to duty in groups of States, performing travel throughout their territories, examining crops, interviewing farmers, country merchants, implement dealers, and others from whom dependable information can be obtained, and reporting each month to the bureau the conditions as ascertained by them.

#### COMPILING THE REPORTS.

The work of finally making the bureau's crop estimates each month culminates at sessions of a board whose personnel, with the exception of the chief of the bureau, who presides, and two regular members, is changed each month. The meetings are held behind locked doors, and all telephone or other communication is effectively prevented until the report is handed to the Secretary.

No other Government attempts to make so elaborate reports nor has so widespread or numerous crop correspondents. But the reports issued from month to month do not purport to be other than estimates; they are not the results of actual enumerations, as are the figures reported decennially by the Bureau of the Census. Every quantitative estimate of this bureau, whether relating to acreage and production of crops or numbers of live stock, is nothing more than a consensus of judgment of many thousands of correspondents and a limited number of agents.

The annual estimates regarding acreage of crops and numbers of live stock are based on corresponding estimates for each preceding year, there being no other bases to which can be applied the percentages of increase or decrease indicated by reports received from correspondents and agents, except once in 10 years, when census figures become available.

It is, of course, out of the question that an agricultural census be taken every year; the expense would be prohibitive. The only way in which the constant and increasing demand for information can be

met is through carefully made estimates. It is not claimed that the estimates of the Bureau of Statistics are strictly accurate; no estimate can be. They are given as the best available data, representing the fullest information obtainable at the time they are made.

If the requirement that an agricultural census be taken hereafter every five years is carried into effect, the estimates of this bureau can be checked up and adjusted to the facts as disclosed by the quinquennial enumerations and new bases for estimates be provided every five years.

#### THE CROP REPORTER.

The Crop Reporter, of which 175,000 copies are printed each month, is sent to all who request it. It is circulated principally among farmers, including the bureau's voluntary correspondents, throughout the United States.

Among the subjects of interest considered in the Crop Reporter during the past fiscal year may be mentioned the following: "Interpretation of the crop-condition figures"; "Wheat movement from farms, monthly, 1910-11"; "Per capita imports and exports of agricultural products, by decades, since 1866"; "Monthly movement of grain"; "Sugar-beet production in United States, 1910"; "Durum wheat exports, 1910-11"; "Cost of producing barley"; "Bushels of weight and bushels of volume"; "Wheat prices in England, six centuries, chart"; "Cost of producing potatoes in United States, by grand divisions"; "Hop movement in United States, 1902-1911"; "Causes of crop damage, 1909-10"; "Stocks of potatoes, January 1, 1912"; "Seedtime and harvest"; "Quantity of wheat and oats sown per acre, by States"; "Wheat supply and distribution, by States"; "Wheat consumption per capita, by countries"; "Egg receipts at seven markets annually since 1891"; "Live-stock receipts at seven markets annually since 1900"; "Farm wages, 1911"; "Stock of wheat in interior mills and elevators"; "Length of service of crop correspondents"; "High prices and crop production"; "Apple shipments on important railroads"; "Index numbers of production per capita and prices of important farm products, 1866-1911"; "Testing of germinating quality of corn"; "Causes and extent of cotton damage"; "Railroads and agriculture."

#### DIVISION OF PRODUCTION AND DISTRIBUTION.

This division conducted an investigation during the last fiscal year concerning the economic results of cold storage and the relationship of cold storage to prices. The aggregate information obtained in this investigation constitutes, in variety and mass, much the largest body of facts concerning this business in its economic aspect that has been collected.

The latest comprehensive investigation of the wage rates of farm labor was completed during the past year, so that the department now has a record of averages of such wage rates for each State, for geographic divisions of States, and for the United States extending back to 1866. A simultaneous investigation was conducted with regard to the supply of such labor, and this constitutes the first comprehensive treatise that has been published on this subject.

The efforts of railroad companies to promote agriculture, especially by soliciting settlers to farm lands, by aiding in agricultural education, and by making other special efforts not strictly to be classed as transportation, were treated in a bulletin which went to press about the close of the fiscal year. The aim of this undertaking is to make practically a complete survey of the activities of the railroad companies in the promotion of agriculture.

In a bulletin published during the year are embraced the dates of planting and harvesting corn, winter wheat, spring wheat, fall-sown oats, spring-sown oats, barley, rye, buckwheat, flax, cotton, and tobacco. The collection and tabulation of materials for another bulletin relating to the forage crops was nearly completed. At the same time a third line of work, the dates of planting and harvesting vegetable crops, has been in hand.

A system was established for the collection of annual statistics of cane sugar and sugar-cane production in the United States and its insular possessions. Statistics of the campaign of 1911-12 for most of Louisiana and Texas and of the campaign of 1910-11 for Hawaii and Porto Rico had been obtained by the close of the fiscal year 1912.

An article was prepared for the Yearbook for 1911 on the reduction of waste in marketing fresh fruits and vegetables, as effected by improved methods of distribution and by better transportation facilities. The regular annual publications prepared in this division included the bulletin on exports of farm and forest products from the United States; the corresponding imports bulletin; a statement giving the shipments of apples on railroads of the United States for the crop of 1911, and another statement showing the exports of durum wheat. Monthly receipts of eggs and poultry at large cities were shown regularly in the Crop Reporter. The production and domestic supply of cotton, tobacco, rice, and hops in the United States, from the earliest available date to the latest, were shown in four circulars. These statistics were formerly included in the Yearbook.

#### DIVISION OF RESEARCH AND REFERENCE.

Ten circulars, each entitled "Foreign crops," have been prepared in the division at regular intervals during the year. In addition thereto, 2 bulletins, 7 circulars, 2 Yearbook separates, 12 monthly editions of

the Crop Reporter, and 3 miscellaneous publications, all prepared in other branches of the bureau, have been read and revised in this division.

Four bulletins, entitled, respectively, "The world production, trade, and consumption of coffee," "Some statistical results of farm bookkeeping in Switzerland," "Land and labor," and "Comparative prices of staple products in leading markets of the United States," are now being prepared in the division and will probably be ready for publication during the next fiscal year.

#### THE PURCHASING POWER OF FARM PRODUCTS.

In 1910 an investigation was made in the Bureau of Statistics which showed that the money value of 1 acre of the farmer's crops in 1909 was 72.7 per cent more than the money value of 1 acre of his crops in 1899; that the average money value of the articles which a farmer buys was about 12.1 per cent higher in 1909 than in 1899; and consequently, as a result of the greater increase in price of what a farmer sells than in price of what he buys, the net increase in the purchasing power of the produce of 1 acre was 54 per cent; that is, the product of one acre in 1909 would exchange for 54 per cent larger quantity of the things farmers buy than the product of 1 acre in 1899. So much public interest has been evinced in this line of inquiry, bearing so closely upon the subject of the "cost of living," that it has been continued during the past two years.

Although the aggregate production of crops in 1911 was about 6.3 per cent smaller than in 1910 and 0.5 per cent smaller than in 1909, the total money value of crop production in 1911, by reason of enhancement in prices, was about 2.1 per cent greater than in 1910 and 3 per cent greater than in 1909. According to a report of the Bureau of the Census the value of all crops in the United States in 1909 was about \$5,487,000,000; on this basis it is estimated that the money value of all crops in 1910 was about \$5,537,000,000, and of crops in 1911, \$5,654,000,000.

The money value of 1 acre of produce in 1911 averaged about \$15.48, as compared with \$15.50 in 1910, \$15.99 in 1909, and \$9.48 in 1899. The larger aggregate value of crops in 1911 than in 1910 and 1909 was due to increased acreage.

An investigation of prices of about 85 articles generally purchased by farmers indicates that such articles averaged in price in 1911 about 1.1 per cent higher than in 1910, 2.6 per cent higher than in 1909, and about 15.3 per cent higher than in 1899.

Taking into consideration the variation in the price of things which farmers buy and in the things which farmers sell, it appears that the purchasing power of 1 acre of crops in 1911 was 1.2 per cent less than in 1910, 5.7 per cent less than in 1909, and 41.6 per cent greater than in 1899.

Upon the basis of the purchasing power of the value of 1 acre of produce, the year 1909 stands as the most prosperous of recent years and apparently the most prosperous for farmers in the past 50 years for which there are records.

#### **LIBRARY.**

The growth of the library during the past year has exceeded that of any previous year. The total recorded number of books, pamphlets, and maps in the library on July 1, 1912, was 122,043. The total number of books and current numbers of periodicals borrowed from the main library and the libraries located in the bureaus and divisions exceeded 180,000. The number of books lent to libraries and scientists outside of the city of Washington was 620. The books borrowed from other libraries for the use of this department numbered 6,405, the majority of which were from the Library of Congress and the library of the Surgeon General's Office.

The total accessions for the year were 9,122, of which number 5,243 were received by gift and exchange. The large number of accessions by gift is especially gratifying, but it is a matter of regret that the funds available for the purchase of books and subscriptions did not permit of larger accessions by purchase.

As the national agricultural library, connected with the national institution for agricultural research, it has been the aim of this library to extend its services as far as possible to the investigators in agricultural science throughout the country. The land-grant colleges and experiment stations, though State institutions, are supplied in part by funds given by the National Government to the States to be used for their maintenance, and they have certain definite relations with the different branches of the National Government. Their relations with the Department of Agriculture are closer than with any other department of the Federal Government, and it is felt that they have, therefore, a just claim to a share in the services of the library of the department. This service the library has endeavored to render to the agricultural colleges and experiment stations through the printing of cards for department publications and for the accessions to the library, through the loan of its books, and by the distribution to them of its duplicates. It has also attempted in a limited way to supply bibliographical information in regard to the literature of agriculture.

#### **OFFICE OF EXPERIMENT STATIONS.**

##### **RELATIONS WITH AGRICULTURAL EXPERIMENT STATIONS.**

The progress of the experiment stations during the past year continued along the same general lines in which advancement was noted the year before. A general increase in equipment, growth in the

various station activities, and organization on a more thorough and systematic basis was recorded, and in many instances the stations were benefited by greater financial assistance on the part of State legislatures and in a lesser degree from other sources.

The appropriations received by the stations as provided for by the acts of Congress amounted to \$1,545,000 for the fiscal year ended June 30, 1912. Since the Adams fund has reached its maximum the Federal funds as determined by the Hatch and Adams Acts remain the same from year to year for all stations except those located in Alaska and the insular possessions, exclusive of the Philippines, for which Congress up to the present has made provision in the annual appropriations for this department. The work of the stations during the past year was aided by State appropriations to the extent of about \$1,250,000, and the Federal and State funds were supplemented by fees, contributions, and amounts realized from the sale of farm products and other sources aggregating nearly a million dollars. The total of the funds at the disposal of the experiment stations for the year was approximately \$3,767,000.

The policy previously pursued by this office in relation to the expenditure of the Hatch and Adams funds was maintained. The inspection of the past year's accounts showed in general a prompt satisfaction of station liabilities and an improvement in the system of accounting. The office has held that the expense of station accounting should be limited to only such a charge against the Hatch fund as is involved in the simple bookkeeping required by this department to show the expenditure of the Federal funds for each fiscal year. Efforts were continued to secure a larger amount of definite experimental work with the Hatch fund by relieving it from charges for administration, compiled publications, and demonstrations.

In accordance with the principle of using the Federal funds only for experimental and research work, the office has continued to emphasize and urge the need of systematizing the extension work and organizing it under a supervision other than that of the stations. The progress made in this direction is illustrated by the fact that already in more than 40 States extension work has been organized under the agricultural college, and extension directors, as special and separate officers, have been appointed and placed in charge of the work.

With regard to station publications, the department took the position that the issue of compiled bulletins of an entirely popular character, as already mentioned, can not be recognized as a proper charge against the Hatch fund, and that all stations should adopt a definite and regular policy in publishing the annual report as stipulated in the Hatch Act. Attention was also called to the importance and advisability of bringing out more conspicuously in the station publica-

tions, by a system of classification or otherwise, the results of research work on agricultural problems, and the belief was expressed that if the issuance of popular compiled bulletins, quite necessary in extension work, be left entirely to the extension departments, much ground would be gained in making the stations' contributions to agricultural science more accessible to the scientific world as well as to the general public.

Numerous lines of important work were pursued by the stations during the year. A brief mention of some of the results recently obtained will give a general idea of the scope and progress of this work.

The Colorado Station demonstrated the occurrence of apparently rapidly extending areas of soil in irrigated orchards and sugar-beet fields containing nitrates in such excessive amounts as to destroy the crops. This excess of nitrates is thought to be due to phenomenal bacterial activity.

The Missouri Station determined that nitrogen and phosphorus are the limiting elements of plant food in Missouri soils and that the majority of Missouri uplands respond to an application of these elements.

Analyses of drainage waters at the New York Cornell Station showed a loss of calcium of over 200 pounds per acre more on fallow than on soil growing corn and oats.

The North Dakota Station found that old land may be made as suitable for growing flaxseed as new land. From experiments and observations the conclusion was drawn that soil deterioration from a chemical standpoint in the principal flax and wheat regions is insufficient to account for the deteriorated yields in quantity and quality, and the deterioration along these lines is attributed to unsanitary soil conditions. The station has worked out specific rotations and methods of culture and seed treatment tending to reduce the activity of these soil troubles.

In studying the relation of soil bacteria to evaporation the Wisconsin Station found that bacterial activity in the soil may so change the nature of substances in solution in the soil water as to exert an influence upon evaporation.

Results secured at the Idaho Station showed a marked increase in protein content of several varieties of wheat grown on land cropped the previous year with potatoes, as compared with land in wheat the year before. Irrigation investigations at this station showed that wheat receiving from 18 to 20 inches of water during the season gave a yield of over 50 per cent above wheat receiving no water and above wheat receiving 50 inches during the same period of time.

The work in agronomy at the Kansas Station brought out quite clearly that the time and the method of seed-bed preparation for



wheat very materially influenced the yield, especially in a dry season. Land disked but not plowed produced  $4\frac{1}{2}$  bushels of wheat per acre, while land plowed at the right time, July 15, and at the right depth, 7 inches, gave a yield of  $38\frac{1}{2}$  bushels.

New varieties of timothy, originated at the New York Cornell Station, have shown strikingly superior qualities in drought resistance. The average yield for 17 new varieties in a dry season was 7,153 pounds per acre as compared with 4,091 pounds for seven check plats of ordinary timothy. Corn-breeding work with two different varieties resulted in each instance in a gain of about two weeks in earliness or time of maturing. Oat hybrids and selections made by the station and tested for five seasons have also shown marked improvement in yielding capacity as compared with common sorts.

The results of a study of the mineral nutrients in bluegrass by the Ohio Station indicated that some bluegrass pastures in the State contain percentages of the mineral nutrients twice as high as others and that these differences are due to differences in the soils upon which the grasses are grown. It was also found that the content of bluegrass in mineral nutrients may be very greatly increased by the use of fertilizers.

Work of the Utah Station has shown that Turkey Red wheat is the best yielding winter wheat of the State, and that the flour produced from it is of the best and equal in quality to any produced in other parts of the country. The work in dry farming conducted by the station on sagebrush land has shown the practicability of farming these lands under dry-farming methods, and as a consequence the greater portion of the sagebrush areas of the State have been taken up.

In its work on weed eradication, the Wisconsin Station found that a crop of hemp after cultivated summer fallow was very effective in killing out quackgrass and Canada thistle.

The plant-breeding and purebred-seed campaign initiated in most instances by the experiment stations is beginning to show notable results from more or less independent efforts. The Wisconsin Experiment Association, for instance, with a membership of about 2,000, is reported as selling annually \$500,000 worth of purebred seed.

Working along the lines of animal nutrition, the Illinois Station discovered that within reasonable limits gain in weight in growing animals is not in proportion to the feed consumed, while the Missouri Station demonstrated that the practice of maintaining young heifers on a high plane of nutrition does not affect their milking quality, and that the size of the cow may be permanently increased by liberal feeding when young.

The Wisconsin Station observed that silage, as compared with soiling crops, can be fed with greater advantage to dairy cows during

the summer season. The South Dakota Station, in testing the value of corn silage and roots for feeding steers, found that when these substances were fed with shelled corn and wild hay there was a larger gain than without these feeds, and that for fattening steers hay with silage proved to be better than hay or silage alone as a roughage.

In horticultural work, the results of orchard experiments by the Missouri Station showed that proper pruning alone on a given plat of peach trees resulted in a yield giving net returns of \$125 per acre. Proper fertilizing with ammonium sulphate on another plat in the same orchard resulted in a yield of \$40 per acre net, while on a plat where proper pruning, fertilizing, and spraying were all combined the peaches yielded a net profit at the rate of \$300 per acre after paying the expenses of management and shipping the crop to market. A successful method of budding the walnut was worked out by the Oregon Station. This method is based on the principle of securing dormant 1-year-old buds, while propagators heretofore have attempted to use buds of the current year's growth.

The Delaware Station, in cooperation with this department, worked out a method for quickly immunizing against anthrax in case of an outbreak, and produced a serum with which it is possible to protect a sheep against an otherwise mortal dose of bacilli and to produce an immediate passive immunity.

In experiments to determine the efficiency of mitigated cultures of human tubercle bacilli as a vaccine against bovine tuberculosis, the Missouri Station found that vaccinated cattle contracted the disease when exposed to infected animals, even under the favorable conditions of an outdoor life. The fecal excretions of tuberculous cattle were a much more important source of infection to swine than foods contaminated with the saliva of tuberculous cattle. Not only a very large percentage of the pigs fed behind tuberculous cattle became infected with the disease, but some of the pigs showed well-developed tubercular lesions in less than four weeks of exposure. This station continued the manufacture of hog-cholera serum and distributed 60,000 doses during the year. In hog-cholera serum work the South Dakota Station showed that 90 per cent of all animals treated safely withstood disease.

The Ohio Station demonstrated the practicability of eradicating bovine tuberculosis and of building up a herd of sound animals from the progeny of tuberculous cattle by the systematic use of the tuberculin test and the thorough disinfection of barns.

In its studies of citrus diseases the Florida Station ascertained that the fungus causing stem-end rot is present in the orchard during practically the entire year, being found on partially decayed branches and twigs when the fruit is immature or after it is harvested.

The New York State Station worked out a method for the preparation of lime-sulphur wash enabling fruit growers to make their own preparations at a very considerable saving. Ten years of potato spraying with Bordeaux mixture at this station resulted in an average increase of 69 bushels per acre from three sprayings during the season, and an increase of  $97\frac{1}{2}$  bushels per acre from spraying every two weeks, or from five to seven times during the season. In a duplicate series of experiments on Long Island the average increase for the 10 seasons was 25 bushels per acre from three sprayings and  $45\frac{3}{4}$  bushels from spraying every two weeks. In a similar way the results of 20 years' work with Bordeaux mixture on late potatoes at the Vermont Station showed an average yield per acre of 268 bushels for the sprayed and of 163 bushels for the unsprayed crops, representing a gain of 105 bushels per acre, or an increase of 64 per cent in favor of spraying.

In a study with a view to adapting the carbonation process of clarifying cane juices, the Louisiana Station discovered features in regard to temperature and alkalinity which enabled it to remove experimentally a much greater per cent of impurities than has heretofore been possible in sugar-house practice. This station also demonstrated that the fuel efficiency of bagasse can be materially increased by utilizing the flue gases in drying this product, and showed, further, how moisture contained in bagasse and other conditions influences its fuel value.

The results of breeding work with poultry at the Maine Station indicate that the female fowl does not transmit the heredity factors to her daughters, but that she may transmit the hereditary factor which makes for high egg production to her sons, and they can then stamp this quality on their female progeny.

We have reached the quarter centennial of the establishment of our national system of agricultural research institutions. Through this entire period the stations have been settling down toward their proper and ultimate research level. The gradual increase of the Adams fund to its maximum of \$15,000 per year has led up to a degree of efficiency in research work which otherwise could not have been reached within the same length of time and with an equal financial outlay. However, before the coming of the Adams fund the stations solved many important practical problems and scientific questions. To enumerate these would be impractical, but as they are rounding out the first quarter century of station activity it might be well to mention at this time one of the first noteworthy achievements of their endeavor to combine science with practice in the development of our agricultural industry. Over 21 years ago the Babcock test was perfected at the Wisconsin Station, and at present is in use in its original form. The scientific principles on which it is

based have not been supplanted, although the mechanical devices employed have been improved. This test made it possible to buy and sell milk on an equitable basis, and thus revolutionized the dairy business in the creamery as well as on the farm. If this practical and scientific method had been established by other than experimentation effort it would have required large sums of money for royalties to satisfy the patent rights; but Dr. Babcock, with the noble conception of the disinterested scientific worker, gave it to the Nation and the world. With achievements of this kind to their credit the experiment stations can look back over their early history with pride and gain renewed zeal and encouragement for the future.

#### THE AGRICULTURAL COLLEGES AND SCHOOLS.

The faith of the people of the United States in agricultural education is becoming each year more apparent in the better support given to the agricultural colleges, in the establishment of additional agricultural courses in universities and colleges of private foundation, in the increasing number of States giving financial aid to secondary instruction in agriculture, in the attention given to the training of teachers of agriculture for secondary and elementary schools, in the large attendance of students at all sorts of colleges and schools in which agriculture is well taught, and in the great popularity of certain forms of elementary instruction in agriculture, such as children's gardens in cities, boys' corn clubs, girls' garden and canning clubs, and other juvenile agricultural club work.

According to a list published April 30, 1912, by the Office of Experiment Stations and compared with a similar list published in May, 1910, the number of land-grant colleges giving instruction in agriculture has increased from 57 to 61 and the number of privately endowed colleges from 24 to 42. Columbia University has established short courses and extension work in agriculture, and Syracuse University has added colleges of agriculture and forestry. Practically all of the State colleges for women in the South now maintain courses in agriculture, giving attention particularly to gardening, floriculture, and poultry husbandry.

Among secondary schools there are now 78 special agricultural schools, as compared with 58 in 1910, and 289 public high schools receiving State aid for courses in agriculture, whereas in 1910 there were 28. Minnesota alone is giving \$125,000 a year to stimulate the introduction of agriculture, home economics, and farm mechanics into public high schools, 30 of these schools receiving \$2,500 a year each and 50 schools receiving \$1,000 each. Kansas, Louisiana, Maine, Maryland, Massachusetts, New York, North Carolina, Virginia, Texas, and Wisconsin are the other States that appropriate funds for this purpose.

Of public high schools teaching agriculture without State aid the number has increased from 432 in 1910 to over 1,600 in 1912, and of State and county normal schools which are giving their students some instruction in agriculture the number has increased from 156 to 196.

These are all institutions for white students. In addition, there are over 100 secondary schools for negroes, 16 special elementary schools for negroes, and 112 schools for Indians, all of which are giving some instruction in agriculture.

The total number of institutions listed in 1910 as having students in agriculture was 863, while at the present time there are 2,575, an increase of 1,712 institutions, or nearly 200 per cent, in two years.

#### FARMERS' INSTITUTES.

The work of the department in aid of farmers' institutes has continued under the direction of the Office of Experiment Stations. Reports received from the several States show that 5,663 regular institutes were held in 40 States. The total number of sessions was 15,965 with a total attendance of 2,272,146. It is estimated that complete reports from all States would show over 19,000 sessions of regular institutes with a total attendance of over 2,500,000. The reports in hand show that the special institutes aggregated an attendance of 1,389,266, making the entire attendance at institute meetings of all kinds nearly 4,000,000, an increase of over 360,000 over the figures for last year.

#### THE DEPARTMENT'S INSULAR AGRICULTURAL EXPERIMENT STATIONS.

The work of the experiment stations maintained by this department in Alaska, Hawaii, Porto Rico, and Guam during the fiscal year 1912 was very successful, and the results of their efforts in attempting the diversification of agriculture are beginning to be apparent. The practicability of farming on a considerable scale, gardening, small-fruit growing, and stock raising in Alaska has been fully demonstrated. In Hawaii and Porto Rico new industries are being developed and old ones revived, so that a much wider field of agricultural and horticultural activity is reported. In Guam the introduction of new crops has been eminently successful, and the restoration of agriculture to its former importance is believed to be assured. During the year some improved breeds of horses, cattle, hogs, and chickens were successfully introduced, and the up-building of the different classes of live stock has been begun.

The appreciation of the work of the several stations is growing rapidly. In nearly every instance the support of the Territorial officials is quite cordially given, and the stations are often taxed

to their limits in supplying information, plants, etc., to the people for whom they are working. The published results of some of their scientific investigations are attracting attention and they are receiving wide publicity through scientific and review journals.

With the rapid development of their work the stations need additional buildings and funds for their support. The Hawaii Station needs a new laboratory building for its horticultural and agronomic work; the Porto Rico Station needs a plant laboratory where breeding, fertilizer, and other experiments can be carried on under controlled conditions; and a similar building is needed for the plant-breeding work in Alaska.

The popularizing of the stations' work through demonstration farms and other means is being rapidly extended, for the most part through funds contributed locally for this purpose.

#### ALASKA STATIONS.

The fall of 1911 was unusually prolonged, and as a result almost every variety of grain and vegetable planted at the several stations fully matured. Apples were ripened at Sitka, five varieties bearing fruit for the first time. The work of producing hybrid strawberries is being continued, and about 1 acre of land has been set to the best of the new hybrids. Other hybrid fruits have been produced and are under experiment to test their hardiness and quality.

The grain-breeding work at Rampart is being continued, and a number of new hybrid barleys of seemingly great promise are under observation. This breeding work will be continued and, as soon as possible, extended to include oats, to get varieties that have stronger straw to withstand winds and at the same time give larger yields of grain. Again it has been demonstrated that winter wheat suffers from the severe cold unless deeply covered with snow. The winter ryes came through much better and gave good yields. More attention will be given to growing winter rye as a staple crop. Plants of alfalfa obtained by Prof. N. E. Hansen in Siberia and northern Europe have been given a trial and have proved hardy for two winters at Rampart. These are being propagated as rapidly as possible to extend their use for forage and to increase the nitrogen of the soil, most Alaskan soils being deficient in this important element. At Fairbanks a very successful experiment in potato growing is reported. On 4 acres of newly broken land yields of 125 bushels per acre were obtained, and on 3 acres of land that had been previously cropped for two years yields of 200 bushels of marketable tubers per acre were secured.

The live-stock investigations on Kodiak Island have demonstrated the possibility of summer pasturing cattle and sheep and their wintering on hay and silage made from the native grasses. About 100 head

of purebred Galloway cattle and 100 sheep were carried through the winter entirely on native forage. Eleven cows with good milking records have been purchased to add to the herd, with the view of developing a milking strain of Galloways. The stock-breeding work received a temporary backset through the eruption of a volcano some 95 miles away covering the entire pasture and hay lands with ashes to a depth of 14 inches or more. This has necessitated the removal of the best of the cattle, and arrangements will have to be made for their future disposal. This will make a serious inroad on the resources of the stations and may require additional support during the year.

#### HAWAII STATION.

Some results of the work of this station in diversifying agriculture are beginning to appear. The pineapple industry has risen to second rank among the industries of the islands, and the station's work on soils, pineapple breeding, etc., has contributed very materially to this extension. The effect of manganiferous soils on pineapple growing has been pointed out, and experiments are in progress that seem to promise good results in rendering the manganese less injurious when present in the soil. The work with cotton has been continued, the best results being obtained with some strains of Caravonica cotton. The station's crop was sold for 18½ cents per pound last season, and the buyers ranked it equal to the best Peruvian rough cotton. This form seems to respond better to perennial culture and is less subject to the attack of bollworms than any others tried by the station. The Japanese rices introduced by the station still give satisfaction, and it is probable that the importation of milled rice from Japan will gradually fall off, the locally grown product taking its place. The experiments with fertilizers have again shown the inability of the rice plant, as grown in Hawaii, to utilize nitrate of soda and the great superiority of sulphate of ammonia applied in the first stages of growth of the rice plant. Somewhat similar work with the taro plant shows that it is readily influenced by fertilizers and methods of culture. Continued work on the propagation of mangoes and avocados shows that when properly understood but little greater difficulty is experienced with their propagation than with ordinary deciduous orchard trees. Experiments in tapping Ceara rubber trees, collecting the rubber, and preparing it for market have been carried out and methods devised that are economically profitable. Rubber prepared by the method worked out was rated in New York as but little inferior to the best Para rubber.

The station's demonstration work that is carried on in cooperation with the Territory and private individuals is beginning to attract attention. Five such stations have been established, where attempts are being made to work out local problems and at the same time give

visual evidence of the results of scientific investigations carried on elsewhere. These demonstration farms, in conjunction with an effort in marketing carried on by the Territory, it is believed, will aid very materially in diversifying the agriculture of the islands.

#### PORTO RICO STATION.

The work of the Porto Rico Station has been continued along the original lines looking to the proper diversification of the agriculture of that island. The fruit industry is rapidly increasing in importance, the exports having increased in value from \$100,000 in 1901 to over \$2,350,000 in 1911. This rapid development has resulted in part at least from the horticultural investigations of the station, which have demonstrated the importance of windbreaks, choice of soils, proper handling of fruit, orchard management, etc. The introduction and propagation of improved varieties of tropical fruits is receiving much attention. Some of these new varieties have fruited and their superiority is plainly shown. Cover crops for orchards are being investigated with pronounced success. The introduction and planting of Eucalyptus trees is being continued, and varieties have been found that are making good growth on the higher and drier lands. The chemical work continues to be largely a study of soil problems. The effect of strongly calcareous soils in inducing chlorosis of pineapples, rice, and other plants has been demonstrated. The fertilizer requirements of the red-clay soils are being investigated, and the causes that result in the so-called "sick" soils are being sought with a view to their probable correction. The plant pathologist and the entomologist are devoting much of their time to coffee pests. The definite causes of several diseases have been worked out and means for their control are being sought. The entomologist is propagating and distributing beneficial fungi and insects for the destruction of certain insect pests. The experiments in the introduction of forage plants are being continued, and among the most promising new plants for this purpose are molasses grass, Rhodes grass, and *Paspalum dilatatum*. Some of these appear drought resistant, and it is thought they will prove valuable for pasture purposes.

The work in improving the live stock is making satisfactory progress. The station added a saddle-bred stallion and a young Morgan stallion to its equipment of stock during the year. The latter animal was secured by transfer from the Bureau of Animal Industry of this department. The number of cross-bred cattle is increasing steadily, and the station has begun the establishment of a dairy herd. At present the only experiment is the production of milk under proper sanitary conditions. The progeny of the half-bred Zebu bulls of the station are in great demand, as the calves are larger, hardier, and make more rapid growth than native-bred calves. The work with



swine was interrupted by the death of the entire herd from some infectious disease. The introduction of poultry is progressing rapidly, but the station is unable to meet all the demands for improved strains.

#### GUAM STATION.

One of the most important events in connection with the Guam Station was the arrival of the purebred live stock from the mainland. These consisted of 6 head of Morgan horses, 5 of Ayrshire cattle, 4 Berkshire hogs, and 8 each of Barred Plymouth Rock and Brown Leghorn chickens. After a trip of a month by transport from Seattle the stock was landed in very good condition. As a precaution they were placed in quarantine for a short period, after which they were transferred to the station. The oldest bull died in about a month with symptoms of tick fever. All the other animals escaped and are reported as growing finely. This stock will be used in an experiment to improve the native stock of the island.

The experiments with field and garden crops generally gave better success than in any previous year, due probably to the improved condition of the soil following cultivation. An extensive experiment with corn has been begun in an attempt to obtain a better yielding variety. This will embrace many tropical varieties, and as corn is a staple food of the island, the importance of its more abundant production is readily seen. The forage-plant investigations have been continued, and Para grass, which was introduced by the station in 1910, has proved well adapted to the island, and several wagonloads of roots have been distributed to natives for planting. It grows rapidly and quickly covers the ground with a thick sward. Experiments with *Paspalum dilatatum* and Guinea grass have continued, but they are surpassed by Para grass for almost every situation and use. Other field crops, including a number of leguminous plants, are receiving attention. Vegetables were almost without exception better in yield and quality than in any previous year. Experiments are in progress in planting vegetables at different times in the year to ascertain for each kind the most favorable planting season. A large number of new agricultural and horticultural crops have been introduced during the period the station has been in existence, and some have already shown their value in their new environment.

A preliminary entomological survey of the island was made by Mr. D. T. Fullaway, entomologist of the Hawaii Experiment Station, who was detailed for that purpose.

During the year the governor of Guam ceded to the station for its use 130 acres of pasture and other land adjoining the station.

#### IRRIGATION INVESTIGATIONS.

The results of the irrigation census taken by the Bureau of the Census in cooperation with the Office of Experiment Stations have

demonstrated four great needs of the irrigated West, namely, (1) more settlers; (2) information and assistance that will enable settlers, both old and new, to make a better and more economical use of their water supply; (3) investigations for the purpose of reducing the cost of pumping and storing of water, of preventing the losses and wastes in distribution and application, and of bringing about a higher duty of water in all irrigated sections; and (4) information regarding better methods of reorganizing irrigation enterprises and operating and managing irrigation systems.

The great need of the irrigated West to-day is not more projects but settlers for the projects that are completed or will be completed within the next few years. The period from 1899 to 1909 saw more than 6,000,000 acres brought under irrigation; yet, making a liberal allowance for the lands that will probably never be profitably irrigated, the enterprises on July 1, 1910, were able to supply water to more than half as much more land; and if the next 10 years is to see two-thirds of the area in projects but not irrigated in 1909 irrigated, 12,000,000 acres must be settled and irrigated. In the past the farming regions of the Mississippi Valley and the irrigated sections themselves have furnished a large percentage of the new settlers, but in the future projects must look more and more to the cities and more densely populated sections of the East for their settlers. The chief irrigation work of the department in the future, therefore, must continue to be the furnishing of information regarding the conditions and possibilities of the different irrigated sections, the cost of obtaining land and water, and the cost and best methods of preparing the land and distributing, applying, and conserving the water, as the success of the individual settlers and the development of the irrigated sections will depend largely upon the newcomers getting properly located, knowing in advance the problems and difficulties to be encountered, and being properly advised and assisted in starting and carrying on their new work.

The average cost per acre of irrigation systems increased 77 per cent and the cost per acre of operation and maintenance 182 per cent in the decade 1899-1909. Further irrigation development, except in comparatively few cases, will be possible only by the construction of still more costly works or by the installation of pumping plants. In but few sections is the water supply sufficient to reclaim more than a small part of the arable land, and thousands of acres of lands will never be reclaimed until a higher duty of water is brought about by the conservation of the flood and out-of-the-season flow of streams, by the introduction of better methods of distributing and applying water, and by the reduction of the waste and losses due to seepage, evaporation, and the applying of water in the wrong stages of crop growth. The data that have been collected and the experiments that

are being conducted by this office have demonstrated that with proper installation and operation irrigation by pumping is feasible in many localities and that a large part of the losses and wastes of irrigation water can be prevented at a cost that will render it profitable to do so.

More than 79 per cent of the area irrigated in 1909 is under enterprises managed by the irrigators themselves, and, judging by the trend of the past 15 years, more than 85 per cent of the irrigated lands will be under such enterprises when the projects being constructed at the present time by the Reclamation Service and Carey Act companies have been turned over to the settlers. Officials of cooperative companies and irrigation districts are constantly facing the complicated problems of organizing and financing enterprises and constructing, operating, and maintaining canal systems, and such advice and assistance as this office is furnishing along these lines is of great importance, especially in those sections where most of the land has been settled and brought under irrigation in the past few years. This work is also of special importance, since the directors of such enterprises, by adopting better rules and regulations governing the delivery and measurement of water and the charges for operating and maintaining systems, and by encouraging the use of better methods and practices, will become one of the most powerful factors in bringing about a greater and better development of the irrigated sections.

#### DRAINAGE INVESTIGATIONS.

##### PROGRESS IN FARM DRAINAGE.

Farmers are gradually coming to the realization that poor drainage of their cultivated lands is not an unavoidable condition, a permanent handicap imposed upon them by nature. The truth is being pressed upon them, not only that the condition can be remedied, but that the more intensive methods of cultivation which inevitably must be practiced in this country will ultimately compel them to drain their wet land in order that they may derive the largest returns from every foot of their cultivated areas.

The department, so far as the means for this work permit, is endeavoring to impress upon the agricultural interests of the country the economy of land drainage. It is attempting, among other things, to discourage the "hit or miss" methods of laying out and constructing tile drains, which methods not only are likely to result in total or partial failure in the particular tracts concerned but also tend to destroy confidence in drainage in general. A considerable part of the work along these lines consists in demonstrating to the farmer the importance of a careful preliminary study of the controlling drainage factors in the tract he desires to improve, and the necessity of intelligent design of the system and rigid superintendence of construction.

To carry out this work the department has stationed specialists in various parts of the country, particularly in the Southern and Western States, whose services are available to communities, organizations, and individuals who desire expert advice upon particular drainage undertakings. Much of this service is of a consulting nature, but where it seems desirable these representatives make detailed examinations of concrete propositions, sometimes making complete surveys and detailed plans, locating the drains upon the ground, and supervising the construction. These representatives also make inspections of tile drainage systems already installed, with a view to collecting reliable data as to their effectiveness under the conditions in which they operate. Experimental work is carried on under varying conditions of climate, rainfall, topography, and soil to determine the best practice in such details as depth, spacing, and size of tile, effective measures to prevent silting of drains, and the necessary provision for surface run-off. In the arid regions the investigations are designed to meet the peculiar problems presented by the rise of ground water, due to irrigation and the resulting accumulation of alkali at the ground surface.

To the extent that time and means have permitted, the existing tile drainage systems in southern Louisiana have been examined in the endeavor to account for the almost universal ineffectiveness of tile drainage that has hitherto obtained in that section. In every case it was found that efficient drainage was precluded either by defective design, faulty construction, or both. The attempt will be made in the near future to overcome the prejudice that has naturally resulted from those failures by supervising the installation of a number of tile drainage systems in that section.

In Alabama an inspection has been made of all the existing tile drainage systems in the prairie section. Four experimental tile systems have been installed, and the results so far observed indicate complete success of this method of draining where the system is properly designed and constructed.

The department has supervised the installation of a number of tile systems in Georgia and the Carolinas which have been highly successful in their operation.

In Maryland, particularly on the Eastern Shore, and in Virginia the service rendered by the department has resulted in an increasing interest in agricultural drainage, several highly successful undertakings of this nature having been carried to completion under the supervision of the representative assigned to that territory.

#### NUTRITION INVESTIGATIONS.

Particular attention has been paid to studies of the use of corn meal and its value in the diet in comparison with other cereals. On the basis of data gathered from experiment and experience, a bulletin

has been prepared which contains much information which should prove of value to the housekeeper and result in an even greater appreciation of this standard American food crop which can be used in the diet in so many ways.

Experimental studies have also been made of the relative nutritive value of different fats and oils commonly employed for table and cooking purposes, and of ways of using rationally this important group of energy-yielding foodstuffs. This work, which involves studies with the respiration calorimeter, has been undertaken in cooperation with the Bureau of Animal Industry.

As a result of the numerous experiments with cheese, a popular bulletin has been published dealing with the economical use in the diet of this food, which gives directions for its use in many ways and discusses its relative value in comparison with other food materials, the general conclusion being that cheese can be used in quantity in a great variety of ways and that it may be employed to replace meat when this seems desirable. Similar work on the nutritive and economic value of dried fruits has been carried on.

The experiments made in cooperation with the Bureau of Chemistry on the respiration and energy output of bananas during the active ripening period has been continued. The small respiration calorimeter designed for this line of work has proved very useful in securing data which are of great interest in connection with the studies of ripening fruit which the department is carrying on. The methods are applicable to the study of a great variety of problems of vegetable physiology of both theoretical and practical interest and such work should prove of much importance to those who purchase, handle, and market such products and to those who use them in the home as well as to investigators interested in technical questions.

Mention should also be made of the increasing demands which are made for publications and other information on the relative value of food and similar topics. Housekeepers on farms and in towns, teachers, pupils, and others turn to the department in increasing numbers for data on such subjects, and it is apparent that the interest is widespread and genuine. Indeed, this has developed into one of the most important activities of the nutrition investigations and is one of those by which the Department of Agriculture directly helps in the solving of home makers' problems.

#### OFFICE OF PUBLIC ROADS.

There probably was never a time in the history of the United States when the question of improved roads was under more serious consideration. The process of centralizing the control of highways has gone steadily on and each year sees an added number of States that have established the State highway departments. There remain

many perplexing questions in highway technique and in the plan of administration and finance for public highways. The work of the Office of Public Roads of this department has fortunately kept pace with the widespread demand for information and assistance in road matters.

#### OBJECT-LESSON AND EXPERIMENTAL ROADS.

There have been built during the present fiscal year 32 object-lesson roads under the direction of engineers from this office. Such roads include plain macadam, oiled macadam, bituminous macadam, gravel, sand-clay, and earth roads. The office has also supplied supervision for the erection of three bridges. Twenty-four object-lesson roads built during past years have been inspected for information to guide future work. Some of these roads are in good shape, some show lack of maintenance, but nearly all have proved a stimulus in awakening interest for better methods of construction. Eight sections of experimental roadway were constructed at Chevy Chase, in Montgomery County, Md. These sections were built for the purpose of determining the relative merits of different forms of bituminous material used as binders and dust preventives on macadam roads. A careful traffic census has been taken each thirteenth day since the completion of the work. It is planned to keep accurate records of the cost of maintenance of the various sections and properly to relate such costs to the traffic sustained by the road.

#### ECONOMIC INVESTIGATIONS AND MODEL SYSTEMS.

There has been an increasing demand for extended inspection by the engineers of the office in various counties. With a view to develop proper model systems of highways, engineers have been assigned to 24 counties. After thorough examination of existing conditions, detailed reports and recommendations have been prepared and submitted. It is necessary in this work to inspect thoroughly the entire county system; to determine the location and quality of road materials; to select the particular roads which carry the main traffic; to examine the financial resources and the plan of road administration and maintenance; and, wherever possible, to prepare maps and sufficient working drawings. Reports submitted to the authorities include all necessary details for carrying out proposed plans of improvement. This model system work has proved one of the most effective ways in which the Office of Public Roads has been able to impart information and render expert service.

#### SPECIAL INSPECTION AND ADVICE.

The office is frequently called upon by road officials and other administrative officers in towns and counties to supply quick advice

on various road matters. Twenty-three States and the District of Columbia have thus enjoyed the benefits of expert advice by highway engineers. Inspection of the State highways of New Hampshire forms the subject of a report issued as Bulletin No. 42, Office of Public Roads. The report treats of the existing conditions and materials, forms of construction, and special problems involved in New Hampshire highways.

#### INSTRUCTION IN HIGHWAY ENGINEERING.

Graduates in civil engineering from engineering institutions throughout the country may become eligible for appointment to the position of engineer student after passing the required examinations of the United States Civil Service Commission. Examinations were held on March 13 and 14, 1912, and from the register established 10 appointments were made. The students who come to the office in this way receive a thorough training in all parts of highway work in the field and in the laboratory. At the end of their first year many prove worthy and are either promoted to serve in the office or to suitable positions in county or State work. At the close of the second year junior highway engineers are eligible to promotion as highway engineer and may ultimately attain the grade of senior highway engineer.

#### PHYSICAL LABORATORY.

The laboratory for the testing of road-building stone has continued to be of large service. Samples have been received from 37 States and Territories, as well as from Canada, Porto Rico, and Wales. Research work in the physical laboratory has progressed satisfactorily and includes the testing of a large number of arch culverts in full-size sections. Studies on the subject of expansion and contraction of concrete while setting have proved of interest and results of value are anticipated when the work has further progressed. Observations have continued on the behavior of oil-mixed concrete, and a bulletin showing the progress of investigations has been issued.

During the year various papers were presented by members of the testing laboratory force on results of research work. A bulletin has been issued on the methods and results of physical testing of road materials.

#### CHEMICAL LABORATORY.

With the increasing use of bituminous materials in modern road construction, the services of the chemical laboratory have become very important. During the year 198 samples of oils, asphalts, tars, and other bituminous materials were received and tested for

their road-building qualities. In addition to the routine work of testing material, research work has been carried forward to determine improved methods of testing bituminous materials and the development of the necessary apparatus.

#### MAINTENANCE.

The attention of all highway engineers has been sharply drawn to the imperative need of better maintenance. Conditions brought about by the increased use of our highways under modern traffic have furnished conclusive evidence of the importance of continuous and adequate systems. An experiment in maintenance on earth roads has been in progress in Alexandria County, Va., on 8 miles of road. The system adopted here is the patrol system. The patrolman is further required to drag the earth road with a split-log drag after each sufficient rain. The results of the work so far indicate that the benefits of such systems can be realized in practice. Detailed information was accumulated as to the proportion of time which it is necessary to devote to the different necessary items of work and the cost of the same. There is a widespread lack of information as to maintenance cost. Considerable work has been done with a view to supplying this need, and it is hoped shortly to issue a bulletin entitled "Repair and Maintenance of Highways."

#### BOND ISSUES.

More and more counties and townships seem disposed to incur debt for road improvement, and it has accordingly become very common for bond issues to be made in amounts from a few thousand to a million dollars. Bond issues have increased so rapidly that the Office of Public Roads has undertaken an extensive investigation to determine the amounts of bonds issued for road and bridge purposes up to the year 1912. Studies are also under way on the methods of retiring bonds, the condition under which the issue is justified, the best method of financing repair of bond-built roads, and to settle the very serious question of relation between the life of the road and the term of the bond issue.

#### LECTURES, EXHIBITS, AND ROAD-IMPROVEMENT TRAINS.

During the year the office has continued its policy of presenting the proper methods of road building and maintenance by exhibits and lectures. The models of various kinds of road construction which are prepared in this office have proved of extraordinary interest and value to the public. Exhibits of models and enlarged photographs of road subjects have been made in cooperation with various railroads



in special cars on good-roads trains. Models have also been exhibited with pictures at various fairs and expositions. There has been a large demand for talks on good-road subjects. It has been possible to assign men for only part of this service. There have been a total of 1,135 lectures and addresses given. The total attendance at such meetings was 208,472.

## **RECORD OF SIXTEEN YEARS.**

### **HISTORY OF THE DEPARTMENT'S SERVICE.**

#### **MANY SUBJECTS OF WORK AND ACCOMPLISHMENT.**

Sixteen years have been of interest in the history of this department. Bureaus have been created and expanded. Lines of research, investigation, and demonstration have been multiplied. Congress has piled duty on duty from year to year. The corps of experts needed in the increasing amount and variety of service has grown greatly. The department has become a great agricultural university for postgraduate work. Discoveries for the benefit of farm practices and improvements of old ones have been countless. The department has both promoted and begun a revolution in the art and science of agriculture. Its influences for agricultural betterment have penetrated all regions of the national domain. At the close of a long administration, filled with accomplishments, it is fitting that the record of 16 years should be written.

### **EXPANSION OF THE DEPARTMENT.**

#### **EMPLOYEES AND APPROPRIATIONS.**

Compared with present proportions, most of the department bureaus of 1897 were small, were getting small results from their work, and were confined to few lines of investigation and endeavor. The whole department had on its pay roll in that year 2,444 persons. The number grew to 6,242 in 1906, and rapidly increased to 9,107 in the following year on account of the enforcement of the meat-inspection law and expansion of work in forestry. The number has increased steadily since that time until on July 1, 1912, 13,858 were on the pay rolls of the department.

During the period under review the paid employees of the Weather Bureau have about doubled in number and are now 2,051. The employees of the Bureau of Animal Industry have increased from 777 to 3,311, and of the Bureau of Plant Industry from 127 to 2,128. The work in Forest Service was so small in 1897 that the paid employees numbered only 14. The number increased to 939 in 1905, to 2,012 in 1907, to 3,636 in 1910, and to 4,127 in 1912.

Only 20 persons were employed in the Bureau of Chemistry at the beginning of this period, and the number increased to 546. From 33, the employees of the Bureau of Soils, the number has increased to 159, and from 21 those of the Bureau of Entomology have increased to 339. The Biological Survey has 97 employees in place of 23 in 1897; the Division of Publications, 188 in place of 61; the Bureau of Statistics, 162 in place of 133; the Office of Experiment Stations, 209 in place of 38. In the Library 6 employees sufficed for the work in 1897 and now 29 are not too many. The Division of Accounts and Disbursements has increased from 10 to 66 employees, and the Office of Public Roads finds it has ample employment for 163 employees in place of 7 in 1897.

It has been a difficult matter to determine how many scientists and scientific experts are employed by the department. It is not always easy to certify that a person is or is not a scientist, but attempts have been made at times in the past, and it is a matter of record that from 1902 to 1907 from 1,927 to 2,326 scientists and scientific experts, assistants, and agents were employed.

Along with the increase in the number of the department employees it is to be expected that the appropriations of money by Congress for the use of the department would greatly increase. For the fiscal year ending June 30, 1898, the appropriations for the department amounted to \$3,272,902. They increased to \$7,109,682.62 in 1905; and by 1907 the amount had risen to \$13,079,523.98. In consequence of the requirements of the enforcement of food laws and the care of the national forests, and in a less degree because of the general expansion of the work of the department, the appropriations by 1911 aggregated \$20,888,449.28, and for 1913 the total amount is \$24,743,044.81.

In wealth produced and in wealth conserved during these 16 years the department has returned to the Nation more than 10 times these appropriations.

## PUBLICATIONS.

### EVIDENCES OF GROWTH AND USEFULNESS.

The publication work of the department is an unerring indication of its growth and usefulness. The records of the Division of Publications, in which such work is centralized, show that in 1897 the mail requests for publications barely exceeded 500 letters per week. So great has been the extension of the department's relations with the farmers of the country in the 16 years which have just passed that, during the past year, the weekly mail has exceeded 52,000 letters, or more than 100 letters for each one received at the earlier date.

With a printing fund of \$116,888, the different publications printed in 1897 were 424, and the editions aggregated 6,541,210 copies; in 1912, with an appropriation of \$470,000, the different publications were 2,110, aggregating 34,678,557 copies.

The work of the Division of Publications reflects, and must always represent, the activity of the other offices of the department. All the information acquired in the several bureaus by the means at their command finds its expression necessarily in the form of publications which pass through this office. Every enlargement of the scope of the work covered by any other office, especially the adoption of entirely new lines of work, involves an addition to the work of the Division of Publications.

The appropriations for the fiscal year 1897 disbursed by this division for salaries, supplies, etc., amounted to \$44,367, while the appropriations for the fiscal year 1912, available for the same purpose, were \$209,960, an increase of nearly 375 per cent.

In 1897 the number of employees in the division was 61, and in 1912 the number aggregated 197, an increase of nearly 225 per cent.

#### NUMBER OF COPIES DISTRIBUTED.

During the 16-year period over 225,000,000 copies of publications have been distributed to those engaged or interested in farming. Of this number slightly more than 88,000,000 copies were farmers' bulletins.

Although the series of farmers' bulletins was begun in 1889, only about 5,000,000 copies had been issued by 1897, and those distributed during that year amounted to less than 2,000,000 copies, while during the year 1912 over 10,000,000 copies were distributed. Previous to the period under discussion only 41 different farmers' bulletins had been prepared, and at this date there are 506 separate pamphlets discussing nearly every phase of modern farm operations.

No other Government issues as many publications as does the United States, and no executive department of this Government issues as many publications as does the Department of Agriculture in performing its function of acquiring and disseminating useful information in regard to agriculture. But the rapid increase in the population of the country and the great popularity acquired by the documents of this department have so augmented the demand that the department has not in recent years had an appropriation that permitted the printing of a sufficient number of copies to meet the demand.

Congress, however, has provided a solution of the problem by authorizing the superintendent of public documents to reprint and sell at a nominal price such documents as may be required. The enormous increase in the sales by that official of this department's

publications is surprising when it is remembered that millions of copies are distributed free, both by the Department of Agriculture and by Members of Congress. During the last fiscal year 171,866 copies were sold by the superintendent of public documents, for which he received \$16,428.

The magnitude of the work of disseminating the vast fund of information so systematically sought and so scientifically verified is commensurate with the enormous advance made in the application of scientific knowledge to practical agriculture by the farmers of the country—a result in which the department has been a marked factor. The improved conditions on farms, the increased yields of crops, the suppression of animal diseases and improved methods of breeding, feeding, and selection of live stock, and the new varieties of fruits resulting from the department's labors as detailed and explained in its publications have added many millions to the wealth of the Nation.

### PLANT INDUSTRY.

#### OUTLINES OF POLICY.

In one of the earlier reports of the present Secretary of Agriculture he set forth the policy with respect to plant-industrial work. It was stated that it would be the aim of the department to bring the scientist to the help of the people; to ascertain what imported crop plants might be produced in our country; to search the world for grains, fruits, vegetables, grasses, and legumes that might be found useful here; to secure new varieties of plants by breeding and selection; to control destructive diseases; to open new markets for plant products, and to improve methods of handling, shipping, and marketing things the farmer grew, especially the more perishable crops. Following is a brief review of some of the more important results accomplished along these lines:

In the earlier stages of the work a cohesive and effective organization was lacking. Twelve years ago the first steps were taken to bring all the forces together, resulting in the organization and development of the Bureau of Plant Industry. Little need be said about the methods and purposes of this bureau. Its work speaks for itself. It has no police or regulatory duties to perform; hence, the energies of its corps of nearly 1,500 laboratory and field men may be devoted exclusively to helping the 6,000,000 or more farmers in ways that have from time to time been set forth in these reports and which have brought about the things herein briefly recorded.

#### NEW CROPS AND NEW INDUSTRIES.

Since 1898, when the plant-introduction work was inaugurated, the department has actively pursued this field of study. At the present time the department has six important field propagating stations,

has brought in something over 34,000 plant varieties and species from every quarter of the globe, and has sent out the progeny from these introductions by the hundreds of thousands to experiment stations and private experimenters and plant breeders throughout the entire United States and its tropical possessions. It has kept a historical record of all these introductions and distributions and accumulated a most extensive collection of data bearing on new economic plants.

This is the first systematic attempt by any government to supply its bona fide plant experimenters on an extensive scale with the material out of which new plant industries can be built.

The department has originated the profession of agricultural exploration and has sent out as agricultural explorers 25 trained men whose search has taken them through many of the cultivated regions of the world and has already been the means of bringing to the notice of the American farmer many of the farm customs and practices of the centuries-old farm civilizations of other countries.

#### AIDING RICE FARMERS.

One of the earliest explorations undertaken in this field was for the purpose of aiding the rice growers of the Southern States. During the year 1898 and again in 1901 an explorer was sent to Japan, China, and India for the purpose of securing short-kernel types of rice better adapted to the conditions of southern Louisiana and Texas and more suited to the needs of the market, especially as regards milling qualities.

The great growth of the rice industry is a matter of history. Lands which 15 years ago were selling at the nominal price of two or three dollars per acre have come to have values of \$30 to \$50 an acre. The total output of rice in this time has increased from 96,886,400 pounds in 1896 to 637,055,556 pounds in 1911. Not all of this advance has been due to the department's introduction work, but the industry received an impetus at that time that has gone far toward making it what it represents to-day.

#### GRAINS AND OTHER CROPS FOR SEMIARID LANDS.

About the time an interest in rice was being developed another explorer was sent to Russia for the purpose of securing help in the matter of grains adapted to our northwestern semiarid regions. A large extent of territory in this section was yielding no valuable crop returns. As a result of this first exploration work in 1898, followed by a second trip in 1900, large quantities of drought-resistant durum wheat and other varieties of wheats, oats, and special cereals were brought in. The results of this work are found in the rapid extension

of the durum wheat throughout the northwest territory and the distribution and extension of the Swedish select oats throughout several of the Northwestern States.

The whole alfalfa question in the United States has been put on a new basis by the introduction of the Turkestan, Siberian, Arabian, and Peruvian alfalfas and the development of the hardy hybrid strains which grow in the Southwest throughout the winter. The introduced Swedish barleys have created a new situation in the barley-growing industry of Montana, Idaho, and California.

#### NEW FRUITS AND OTHER CROPS INTRODUCED.

The seedless grapes of Italy and Greece have begun to have their effect on the table-grape and raisin industries of the Pacific coast. The Bohemian horse-radish has supplanted the old variety in New Jersey as a better yielder and a better flavored sort.

The date palm has ceased to be a curiosity in the desert regions of the Southwest, and its cultivation is becoming an important plant industry. The dasheen, a root crop for the South, has proved its possibilities as a food producer and will probably rival the potato in the South for lands too moist for this staple crop.

The Chinese wood-oil tree, from the nuts of which the best varnish oil in the trade is produced, has fruited successfully in the Gulf States and promises a new crop for cheap lands which can be harvested during the slack-labor season.

The Chinese wild-peach stock has proved to be hardy in the Middle West in sections where the hardiest varieties heretofore known have been killed to the ground, and it also promises to be the earliest stock in California. Groves of the timber bamboo are now established in Florida and Louisiana.

Groves of the superior-flavored oriental mango, first encouraged by the department, are now fruiting in Florida, Porto Rico, and Hawaii, and this fruit tree is beginning to attract attention in southern California.

The Guatemalan and Mexican avocados and selected seedlings of West Indian and Florida origin are creating a new fruit situation in California and Florida.

The Smyrna fig industry of the Pacific coast is now established, and the introduction by the department of the insect-carrying capri-fig has become a matter of history. Over 1,000 tons of this choice fig were produced last year.

The pistache nut of the Orient, together with its relatives from China and the Mediterranean region, have been introduced and proved valuable for Pacific coast conditions.

The introduced Chinese jujube has proved adapted to Texas and other portions of the Southwest, and a new dry-land fruit tree, comparable in a measure to the prune, has been added to our horticulture for semiarid regions.

The Chinese persimmon varieties have proved quite as well adapted to conditions in America as the Japanese varieties and are showing certain advantages over them. They have added a distinct new type of fruit to our fruit culture.

The cork-oak acorns, which were early introduced, have grown into large trees and have demonstrated the possibility of growing American cork.

#### EXPLORATIONS UNDER WAY.

During the past year an agricultural explorer was sent through the steppe regions of western Siberia, south of Omsk, to make a detailed study of the behavior of the yellow-flowered, hardy alfalfa on the cattle ranches there, and he made contracts with the peasants for all the possible seed for special experimental tests of this plant in the Northwest. He imported the Siberian bush cherry, which he believes will become important for the extreme northern tier of States, and the Siberian larch, which is the fastest-growing conifer of that region, together with several hundred dry-land grains, forage crops, and fruit-tree varieties.

As a result of a survey of the East Indian cattle-raising country, which the forage-crop expert of the department was sent to make, some promising Indian forage grasses were secured, which may prove valuable for the Southern States. An investigation of the Egyptian date region resulted in the introduction of new varieties of date palms for the experimental plantings in the Salton Basin.

A special effort has been made to secure plants from the dry and cold regions of central Asia, including the little-known Chinese Turkestan. This exploration work has been continued actively the past year. As a result of the establishment of a new plant station in North Dakota, at Mandan, it has been found necessary to look further for crops that may be brought in, established, and tested at the station, with a view to using them for breeding purposes and distribution throughout the entire Northwest to help the farmers of that region.

Numerous types of dry-land poplars and other trees suitable for wood, windbreaks, etc., have been located. Valuable shipping varieties of table grapes, hardy wild apples and apricots, and a number of wild forage legumes from the Siberian steppes have been located and are now being secured in quantities for distribution and testing in the years to come.

## SPECIAL WORK ON FORAGE CROPS.

A great many valuable introductions have been made through correspondence and in ways other than through explorers. This is the case with forage crops for nearly all parts of the country. Sudan grass, a wild form of sorghum, although introduced only four years ago, is now greatly in demand in the southern portion of the Great Plains region on account of its ability to produce an abundance of good forage under conditions of low rainfall.

In Florida and the immediate Gulf coast region a good hay grass has long been a desideratum. Rhodes grass, secured from Africa, promises practically to solve the hay question for that portion of the South.

Renewed interest has been awakened in the soy bean by the establishment in general use of new varieties secured from China and Japan. These varieties have proved far superior to those originally grown. Likewise, new and improved varieties of cowpeas have been introduced and developed, thereby extending materially the usefulness of this very important crop. The origination of improved varieties of timothy by selection and breeding has opened up great possibilities along the line of improving the most important grass-hay crop for the United States.

Much attention has been given to the extension of alfalfa, and our efforts have met with marked success. At the present time this valuable forage crop is becoming a staple in many sections of the Eastern States and promises to increase rapidly in importance during the next few years.

During the past year marked advance has been made in the work with the hardy and drought-resistant alfalfas introduced from Europe and Asia. The crossing of the yellow-flowered form with the common species has resulted in some very promising hybrids adapted to use both as hay and for grazing in the Great Plains region. The value of the new alfalfa for hybridizing can scarcely be overestimated.

The increasing difficulty of obtaining and maintaining profitable stands of red clover has long been a matter of serious concern in many parts of the clover belt. Investigations started last season are already indicating the solution of this problem. Efforts to develop methods of handling the clover-seed crop in order to make it more certain are meeting with success.

Rhodes grass and Sudan grass have this season even surpassed expectations. Extensive seedings of both of these grasses have been made, so that there is now abundant evidence of their value under field conditions.



Work with the sorghums and other drought-resistant forage crops has continued to give results of great importance to the dry land of the West.

#### AIDING THE IRRIGATION AND DRY-LAND FARMER.

##### AID FOR IRRIGATION AGRICULTURE.

The past few years have witnessed remarkable growth in the development of agriculture in all that region lying west of the one hundredth meridian. The great irrigation projects undertaken by the Government and private agencies have stimulated an interest in agriculture to such an extent that the department has found it necessary to give help along many lines of crop production. To do this, investigational work was necessary.

This has been carried on, in so far as relates to irrigation agriculture, at eight field stations located in the Western and Southwestern States. All these stations, with two exceptions, are operated in cooperation with the Reclamation Service. The primary object of these field stations is to furnish investigational bases at which the various specialists of the Bureau of Plant Industry can work, with a view to getting an understanding of agricultural conditions and problems which characterize the different sections. They are also intended to facilitate cooperation in the solution of problems relating to irrigation agriculture, the improvement of existing industries, and the investigation and establishment of promising new industries.

In addition to the purely investigational work, a great deal has been done in fostering community action with respect to the development of industries especially adapted to the irrigated regions.

The major portion of the work at the field stations is still in progress, but some lines have been completed, and in these and other lines numerous specific results have been accomplished.

At the San Antonio field station it has been found that the ravages of the sorghum midge, which formerly did very great damage to the grain-sorghum crop, can be entirely avoided by the practice of early planting; that the utilization of indigenous fruit plants as stocks for cultivated varieties greatly improves the possibilities of fruit production in that region, because the native stocks are better able to withstand the conditions of soil and climate peculiar to the locality; that certain varieties of forage sorghums, winter oats, and annual legumes are very much more dependable as forage crops than anything that was generally grown in the section prior to the establishment of the station; and that one variety of Canada field peas, useful as forage, green manure, and as a winter cover crop, will successfully withstand the winter temperatures and produce a satisfactory yield.

An important part of the work at the Yuma field station, at Bard, Cal., is the experiments with Egyptian cotton conducted in cooperation with other offices of the bureau. It has been found that the methods of planting, cultivation, and irrigation as practiced in Egypt are not applicable to the southwestern United States. Upon the recommendation of bureau officials, about 700 acres of land were planted to the crop this year in cooperation with farmers on the Salt River, Yuma, and Imperial Valley irrigation projects, and two specialists have been detailed to supervise the field work of the cooperating farmers. The results so far are extremely encouraging.

The work on the Williston project in North Dakota consisted chiefly in giving expert assistance in the construction and use of farm irrigation systems to the new farmers who came to live on the irrigated lands. At the close of the present season it was found that the work had progressed far enough to enable the farmers to dispense with the services of the irrigation expert who had been maintained at Williston, and his employment was therefore terminated.

At the Fallon (Nev.) field station one of the chief problems has been the devising of methods for the reclamation of the highly impervious alkaline soils which comprise a large part of the Truckee-Carson project. Various methods have been attempted without success, but recent experiments strongly indicate the practicability of using gypsum or lime on the soil to increase its permeability and installing farm drainage systems to carry away the alkaline salts leached out of the soil by irrigation. One more year's results will be required before this method can be recommended with certainty.

Probably the most serious problem which has been encountered on the project is the eradication of the nematode gallworm affecting potatoes and some other crop plants. In 1910 and 1911 the disease was so extensive as seriously to threaten the potato-growing industry in Nevada. Investigation has shown that certain crops are seldom or never affected by the gallworm, and that the growth of these crops for a series of years affords about the only effective method of eradicating the parasite from infested areas. A publication giving suggestions for the avoidance and eradication of the pest was issued in February, 1912, and distributed among the farmers of Nevada.

A considerable quantity of educational work has been done on the project, not only with field and garden crops, but with ornamental plants for use in home making as well. Several thousand shade trees have been purchased and set out by the farmers under the direction of the farm superintendent, and excellent growth has been made, particularly by black locust and Carolina poplar.

The work at the Umatilla Experiment Farm, at Hermiston, Oreg., is comparatively new, but some few definite results have already been secured. It has been found that young nursery stock is very much more dependable for orchard planting on the Umatilla project than trees two or more years old. The experiments with winter cover crops have shown the superiority of the vetches for such purposes. There has been noted a decidedly depressing effect on the growth of the trees where alfalfa is grown in the orchard close to the trees.

#### DRY-LAND AGRICULTURE INVESTIGATIONS.

For the past 30 years there has been an ever-increasing interest in the agricultural development of the fertile plains extending from the base of the Rocky Mountains eastward for an average distance of about 300 miles and from the Canadian boundary on the north to the Gulf of Mexico on the south. This area is known as the Great Plains. It is in this area that dry farming has reached its most extensive, if not its highest, development.

The term "dry farming" is one that has come into general use to meet the need of a descriptive name for that type of farming which has been developed without irrigation in semiarid regions where irrigation is desirable but impracticable.

Prior to the year 1906 the department had carried on various lines of investigations in this area, dealing with some of the more important specific agricultural problems, such as grain and forage-crop investigations, but by this time it had become evident that if the agricultural problems which the settlers and home builders had to meet were to be solved there must be a much more comprehensive plan of investigation devised.

To meet this need the Office of Dry-Land Agriculture was organized and placed in charge of a man who had had long experience in this region both as a practical farmer and as an investigator at one of the State experiment stations. In the organization and development of the work the following objects were recognized as fundamental: To establish and maintain close personal contact with the actual settlers and their problems and to work out these problems under the same soil and climatic environment as that surrounding the settlers; to establish a sufficient number of field stations, so distributed as fairly to represent the area as a whole; to have these stations established on a permanent basis, so that the work would continue uninterruptedly through a long series of years; to have the work at all the stations so thoroughly coordinated that results obtained at each would be comparable with that of all the others; to enlist the active cooperation of the State experiment stations and of the various bureaus and offices of the department, of State, county,

and municipal organizations, and of practical farmers along all lines of investigation having a bearing upon dry-land farming.

With the above-mentioned considerations constantly in mind, the work of the Office of Dry-Land Agriculture has rapidly developed in the last six years, until it now has under actual operation or in process of development six fully equipped field stations under its own financial and administrative control, and provides field and laboratory facilities for many other cooperating investigators. These stations are located at Mandan, N. Dak.; Ardmore, S. Dak.; Akron, Colo.; Woodward, Okla.; Dalhart, Tex.; and Tucumari, N. Mex.

It is carrying on its investigations in cooperation with the Office of Western Irrigation Agriculture at three stations, namely, Huntley, Mont.; Bellefourche, S. Dak.; Mitchell, Nebr.; and with the Office of Cereal Investigations at Amarillo, Tex.

It is conducting its work in cooperation with the State experiment stations at eight stations, namely, Judith Basin, Mont.; Williston, Dickinson, Hettinger, and Edgeley, N. Dak.; North Platte, Nebr.; and Hays and Garden City, Kans.

At all of the above-named 18 stations investigations in crop rotations, cultivation and tillage methods, the conservation of soil moisture, and meteorological observations are being conducted in a systematized manner. In addition to these, many special problems are being studied through cooperation with other investigators.

If this work continues to develop in the future as it has in the past six years, it will result in the accumulation of a mass of carefully recorded and thoroughly coordinated scientific data based upon original investigations and having a direct bearing upon the fundamental agricultural problems of a vast area, such as has never before been undertaken, and the value of which to the present and to future generations can not be overestimated.

If this country is to continue to produce food for its own people with a surplus for export, all of the fertile semiarid lands must be made to produce some kind of food product, and this must be done without the fearful loss in ruined fortunes and wrecked lives which has accompanied the unsuccessful attempts in the past to develop the agriculture of some parts of this area. This can be accomplished by a thorough understanding of the problems involved, which can be gained only by investigations of this character and scope.

#### CROPS RESISTANT TO ALKALI AND DRY-LAND CONDITIONS.

Problems chiefly associated with irrigation and dry-land agriculture have to do with alkali resistance of various crops. The alkali resistance of numerous crop plants has been tested comparatively at field stations in the Western States, and the results have been supplemented by observations in northern Africa, where agriculture has

been carried on for many centuries in the presence of alkali. The data thus obtained have made possible definite recommendations regarding the crops best adapted to various types of alkali in the United States. Laboratory experiments during the same period have afforded much information concerning the relative toxicity of the different alkali salts and concerning the influence of alkali upon the utilization of soil moisture by plants.

Success in breeding crop plants for dry-land agriculture depends upon a thorough understanding of those features of structure and function which enable plants to cope with a meager supply of water. Recent field and laboratory investigations of the bureau have largely cleared up the obscurity surrounding this subject. Adaptability to dry-land conditions has been found to depend not, as has generally been supposed, upon superior ability to extract water from a dry soil, but, primarily, upon ability to manufacture a given quantity of dry matter with a minimum expenditure of water. The results of these physiological investigations are being practically applied in breeding drought-resistant strains of various crops for the Great Plains region.

The native vegetation on different types of land in the Great Plains and Great Basin regions has been studied in relation to the various factors of physical environment. The results prove that the composition and character of the natural growth is a reliable indicator of the capabilities of the land for crop production, reflecting with remarkable sensitiveness the average conditions with respect to soil moisture and the presence or absence of injurious quantities of alkali. These investigations indicate that the native vegetation can be used in the rapid and accurate classification of new land as (1) suitable for dry farming, (2) suitable for crop production under irrigation, and (3) nonagricultural.

#### PROGRESS IN COTTON WORK.

For the past 12 years systematic work has been carried on with a view to discovering fundamental principles which would aid the producers of the South in the matter of securing better types, larger yields, and varieties of cotton resistant to various diseases. The breeding work has resulted in securing numerous varieties which have taken their place among the people as standard sorts.

The advent of the boll weevil made it necessary to give careful consideration to the readjustment of cotton varieties throughout the invaded territory. This work led to discoveries of great importance in the matter of local adjustment, a hitherto neglected factor. It also developed the important fact of the serious deterioration of cottons by chance hybridization.

As a result of these several lines of work the importance of community action as a means of limiting the cotton grown in any particular region to a single variety has been shown. It has been further shown that the methods necessary to preserve a variety are totally different from the methods employed to develop new varieties. As the work of improving the types developed it became more and more evident that decisive steps had to be taken in the matter of aiding the producers of cotton in marketing their product.

With a view to bringing this about the department for a number of years conducted certain work directed toward bringing about improved conditions, especially through the establishment of national standards for American cotton. Recently those phases of the work dealing more specifically with handling and marketing have assumed such importance that an independent project has been established for their proper conduct.

That the prevailing methods of distributing this great staple crop require radical improvement and simplification has been recognized for some time. The present methods are expensive and wasteful of fiber. They are so highly complicated that only the specialist middleman, very rarely the grower, is able to operate successfully in the selling end of the business. There are opportunities for inaugurating improvements all along the line from the time of picking until the staple reaches the spinner, but no one element in the industry acting alone can bring about the necessary changes.

The department inaugurated and is developing the movement toward cooperation in the matter of growing cotton and cooperation in the matter of marketing of the same. A study is being made of cooperative efforts in the handling of other crops, and educational work is being conducted in order to place in the hands of farmers the information necessary to enable them to organize for producing and marketing purposes.

#### ADVANCES IN CORN CULTURE.

The past 12 or 14 years cover history of great interest regarding the improvement of our most important crop. At the beginning of this period little concerning the improvement of corn had been recorded. Plant breeding attracted wide interest, and general attention turned suddenly to corn. All sections of the country were filled with descriptions of points that constitute fine-appearing ears of corn. By many careful workers these points were strictly adhered to for a number of years, resulting in demonstrating that in appearance corn is readily improved, but that fine appearance is not necessarily an indication of greater productiveness or profitableness.

When these facts were thoroughly established by practical field work, the general interest in "fancy point" breeding gave way to a

general demand for a method of corn improvement that would prove profitable. Our corn investigators in 1901 took up work under different environmental conditions to determine methods of corn improvement that would give profitable results. Methods of corn breeding and seed selection have been pursued during the past 12 years at these points with results proving that judicious breeding makes possible the production of much more profitable corn crops than can be otherwise obtained.

The methods of breeding that have proved most satisfactory are those that have been modified from time to time to suit the changing requirements of the strain of corn and its adaptation to its environment. It has not been by established methods, but by the constant exercise of good judgment that substantial and profitable improvements have been accomplished.

These demonstrations under various environments that by seed selection alone various varieties of corn can be rendered 25 or 50 per cent more productive, are serving to start corn-improvement work in many counties. Local features are so largely involved that much of the work must be accomplished by local enterprise, and where the possibility of substantial results has been demonstrated local enterprise is taking hold of the work so enthusiastically that the department has had more calls for leaders, plans of operation, and solutions of corn problems than it has been possible to supply.

The past year's work has added further proof that some of the many imported strains of corn having diverse characters and adaptations are proving of great value in localities in which their peculiar adaptations of drought or insect resistance are needed.

Because of its intrinsic value the corn crop is rapidly becoming linked with nearly all the leading enterprises of our country. It is now more than a question of growing corn. There are questions of kind and quality and methods of utilization to be considered from hygienic as well as financial viewpoints.

The demonstrations that have proved that profits are greatly increased by the application of methods of corn breeding, seed selection, seed preservation, judicious crossbreeding, etc., have returned financial values far in excess of the cost of making the demonstrations.

#### RESULTS OF THE TOBACCO INVESTIGATIONS.

In the tobacco work, which was inaugurated in 1898, it was apparent from the outset that the average yield and profit per acre from this crop were comparatively small, and it was found that this condition was due primarily to the growing of mixed and undesirable types, failure to follow sound cultural methods, particularly in the matter of crop rotation and fertilization, damage to the crop from

insects and diseases, and lack of understanding of the vital features of successful curing, fermenting, and handling of the leaf. All of these problems have been taken up, resulting in marked improvements in the old methods of tobacco production.

The old standard types have been improved by seed selection, and in the Connecticut Valley, Maryland, and Ohio new types have been produced by breeding which are much more productive than the old types. Desirable foreign varieties also have been successfully introduced, such as the Sumatra and Cuban wrapper leaf and the filler grown from Cuban seed.

It has been clearly demonstrated that in most of the export and manufacturing tobacco districts the continued growing of clean-cultivated, humus-depleting crops on the tobacco lands, with little or no attention given to soil-improving crops like the grasses and legumes, combined with improper methods of fertilizing, is the primary cause of the small yields of tobacco.

A great deal of hay has been imported into these districts each year, while practical demonstrations have shown that the growing of grasses for hay is just what is most needed on these soils to obtain the best results with tobacco. Our experiments and demonstrations have shown beyond doubt that the yield and value of the tobacco crop in these sections can easily be doubled by combining well-planned systems of rotation with the use of the proper quantities and forms of commercial fertilizers. It has also been shown that the growing of winter cover crops is highly beneficial to tobacco.

The fundamental principles of curing and fermenting have been thoroughly studied and practical applications of the results of these studies have been made in the cigar-wrapper leaf and flue-cured districts with striking success. It has been shown that the diseases and damage from other causes during the curing processes can be readily controlled by proper methods. Among the field diseases of tobacco which have been brought under control may be mentioned particularly tobacco-root rot, which formerly did much damage in some sections.

The tobacco work of the last year has followed along the same general lines as formerly. The work with the export types in Kentucky has been extended into Tennessee, with headquarters at Clarksville. The principal results obtained are the development of a very promising new type for the broad-leaf district of the Connecticut Valley, very large increases in yields of tobacco from improved methods of fertilizing in New York State and from crop rotation and fertilizer demonstrations in the manufacturing and export districts, and effective demonstrations in improved methods of curing in the flue-curing and in the Burley districts.



## PURE SEED FOR THE FARMER.

Great progress has been made in the matter of securing good seed for the farmer. The early laboratory work inaugurated has been gradually extended until the present time, and the laboratory located in Washington, together with the five branch laboratories maintained in connection with the State agricultural colleges and experiment stations, has tested more than 120,000 samples of seeds for purity or germination or both.

This work, continued from year to year, has resulted in a much better understanding of the nature and value of pure seeds and has added much to the upbuilding of agriculture. As a result of the information contained in publications on adulterated seeds the sale of adulterated alfalfa and clover seed has practically ceased, and the quantity of other adulterated forage-plant seed on the market is now small in comparison with what it was when these publications were undertaken.

Among the results to which the work of this laboratory and those of the State experiment stations have contributed is an awakened interest in better seeds on the part of farmers. This is evidenced by the steady increase in the proportion of high-grade seeds on the market each year. Seedsmen are now taking an active interest in seed testing. They are themselves learning to test seeds, and many firms have fitted up seed-testing laboratories of their own.

The seed-importation act passed at the last session of Congress will prevent the few unscrupulous seed dealers from bringing into the United States low-grade forage-plant seeds which do not find a sale in foreign countries, but which have previously been imported into the United States in considerable quantities.

During the past year the seed-testing laboratories have been continued. The work has been carried on along lines similar to that of previous years. The investigational work has been divided between studies on the physiology of germination and the critical examination of closely related seeds with a view to their easy recognition. Forage-plant seeds, including redtop and hairy vetch, have been examined for the presence of adulterants. Samples of seeds submitted for the purpose of analysis have been examined and reports on their quality have been made to the persons sending the samples. Branch laboratories have been opened in cooperation with the agricultural experiment stations in California and Louisiana, and those in Oregon, Missouri, and Indiana have been continued.

## ARLINGTON FARM AND HORTICULTURAL INVESTIGATIONS.

The area developed as the Arlington farm was transferred from the War Department to the Department of Agriculture in 1900. The

improvement and development of the farm as a field laboratory for the Department of Agriculture was seriously started in 1900. Surveying, grading, and draining operations were begun the first year. Since then the present equipment, consisting of two dwellings, a large barn, shop, tool storage and boiler house, greenhouses, tool sheds, drug laboratory, and refrigerating plant, has been installed.

Previous to 1901 all the attention given to the vegetable crops originated in the Division of Pomology. Coincident with the development of the Arlington farm activities along the lines of market gardening, truck farming, and vegetable gardening were undertaken.

The Irish-potato investigations are to-day represented by a chain of field stations located in Maine, New York, Virginia, West Virginia, Michigan, Wisconsin, Minnesota, North Dakota, Nebraska, Colorado, California, and Idaho, which have been developed since 1903. Varieties of potatoes have been obtained from Europe and from South America, in addition to those common in the American trade, to test their disease resistance. Tests are under way to determine the adaptation of varieties to special localities for commercial purposes, as well as to determine those localities that can most economically produce seed of superior merit for regions which have to depend upon a foreign seed supply. The hill-selection and tuber-unit method of breeding potatoes for maintaining the vegetative vigor and productivity of our standard sorts has been improved and has given remarkable results in some regions where crop failures have been a severe blow to the potato industry.

The sweet-potato investigations, which were undertaken about the same time as the Irish-potato investigations, have resulted in determining the identity of varieties and have developed a method of utilizing the sweet potato for stock food which needs only to be carried to those regions where sweet potatoes can be cheaply produced. At the present time an effort is being made to solve the storage problems of sweet-potato growers.

The peanut investigations, which were begun in 1905, have proved of great advantage to the boll-weevil districts of the South by carrying to these regions a money crop of as great value as cotton, thus increasing the desirability of establishing a crop-rotation system. The invention of machinery that takes the place of hand labor in digging and picking the nuts has removed the industry from one confined to small areas, because of labor restrictions, to an industry which can be conducted on as extensive a scale as potatoes, beans, or other crops which require similar handling.

At the beginning of these investigations no peanut-oil industry existed in America. At the present time several of the cotton mills located in the peanut-producing area are installing machinery for the expression of peanut oil. Coincident with the expansion of the

peanut industry through the South, a remarkable extension of the use of the peanut both as a human food and as a stock food has developed. Single firms use as many as 150 carloads annually in the manufacture of peanut butter and confections.

#### PROGRESS IN POMOLOGY.

The fruit industries of the country are assuming large proportions. Their growth, especially during the past decade, has been rapid. The work of the department in this field has for its object the aiding of fruit growers along a number of important lines. Special efforts have been put forth in the matter of educational work in connection with the simplification of fruit nomenclature. As the interest in orchard and fruit planting develops, there is more and more demand for authentic facts relative to varieties. The identification, classification, and grouping of varieties have formed an important line of work and have been fully systematized and organized, to the end of helping fruit growers everywhere.

#### MAPPING OF FRUIT DISTRICTS.

Early in the development of the pomological work it was deemed important to inaugurate investigations in connection with the mapping of fruit districts. It was understood that certain kinds of fruit would succeed in one place and would not succeed in another. No very definite and specific information was at hand as to the factors governing successful fruit production in different parts of the United States.

Work along these lines has proceeded now for 10 years, with the result that some of the more important fruit regions of the Eastern States and the western central portion of the United States have been indicated. Last year this work was extended into Oklahoma, Kansas, Nebraska, northern Texas, and portions of New Mexico and Colorado.

#### FRUIT MARKETING, TRANSPORTATION, AND STORAGE.

One of the most important fields of effort in aiding the fruit grower has been in the direction of fruit marketing, transportation, and storage. These investigations have been pushed vigorously now for nearly a decade, with the result that in a number of sections of the country the handling, transportation, and storage of fruits have been practically revolutionized. This is especially the case in southern California, where the conditions affecting the fruit industry, including the cooperative-marketing organizations among the fruit growers, afford an unusually favorable opportunity to work out through experiments in orchards and packing houses the fundamental principles involved in fruit handling and storage.

Studies of transportation conditions pursued on transcontinental trains and in the receiving markets were also prosecuted. These studies have resulted in the development of that preparatory treatment of fruits for transportation known as precooling, which appears destined to play a very important part in the future development of transportation and storage of all perishable horticultural products.

The beneficial results of this work are already apparent in many fruit-growing sections of the country where, with some modification, the principles discovered in California have been applied in the commercial handling of fruits, including the orange and pomelo shipping in Florida and the peach, pear, grape, and berry shipping of both the Eastern and Pacific Coast States.

The viticultural industries of the country have been looked after in connection with the general fruit work of the department. Experimental vineyards have been established in California and elsewhere with the object of securing data relative to the governing principles in the matter of successful crop production.

A special effort has been put forth in encouraging the production of grapes in the Southern States, especially those of the Muscadine types. Nut culture has also received special attention in connection with the progress of the general fruit work. Studies have been made of the principal species of nut trees grown in the States east of the Rocky Mountains with a view to determining the adaptability of the varieties. Further studies have been made of the details of orchard operations with a view to advising and assisting those who are desirous of engaging in this industry.

#### SEED DISTRIBUTION.

It is gratifying to review the progress made in the securing and distribution of seeds by the department. By a combination of clear-cut business principles and scientific knowledge the work has developed smoothly along satisfactory lines. Within the last decade, ever since the work has been handled exclusively by the Bureau of Plant Industry, more than 7,000 tons of seed have been secured, tested in the laboratory and in the field, assembled, and distributed.

Early in the work it was determined to conduct it in such a way that all the seed secured and sent out should be of high quality. It was determined furthermore to eliminate costly practices of hand work and to introduce, wherever practicable, modern mechanical appliances for facilitating operations.

Notwithstanding the fact that the quantity of seeds secured and distributed has nearly doubled in the past 10 years, the actual cost of handling the distribution is less now than it was 10 years ago. The funds saved by good business management have gone toward improving the quality and quantity of the seed and have enabled

the department to take up a number of special lines which have resulted in much good.

Special features of seed distribution have been maintained, such as securing and distributing types of cotton better adapted to certain conditions in the South. Many of these types have been developed through breeding and selection. The extensive propagation of new types of citrus fruits adapted to home use has also been followed. Large numbers of citranges developed by the plant breeders of the department have been propagated and sent out under congressional distribution. Large quantities of special forage-crop seeds have been distributed in all parts of the country.

There is just now being put into effect a plan for the distribution of special seeds adapted to dry-farming conditions. The future success of dry farming in the semiarid districts will depend in large measure on the adaptation of suitable crops for these districts. An appropriation was made for this purpose at the last session of Congress, and special types of sorghums, wheats, oats, barleys, grasses, and legumes of various kinds will be distributed the coming year throughout the entire semiarid region.

In connection with the congressional vegetable and flower seeds there has been a steady improvement in the quality distributed, and that this has been appreciated is shown by the increased demand for them. That part of the congressional seed distribution covering vegetables and flowers for 1912-13 will require about 600 tons of material. These seeds will all be assembled, packeted, and distributed by the 1st of April, 1913. In round numbers, about 61,000,000 packets will be put up and mailed. In addition, there will be special sets of cotton seed and special sets of seed adapted to dry farming, as already indicated.

#### GRAIN GRADING AND GRAIN STANDARDIZATION.

The investigations pertaining to the conditions affecting grain crops after production, i. e., the methods of harvesting, transporting, grading, and marketing grain, have been productive of excellent results. During the year approximately 25,000 samples of grain have been tested and analyzed. Tests for acidity, which denotes soundness, were made of over 5,000 samples of corn. Stock-feeding tests are now being conducted in cooperation with the Bureau of Animal Industry, to determine whether or not corn of high acid content is detrimental to stock as food.

Definite progress has been made in determining the changes which take place in grain while in storage and in railroad and ocean transportation, special attention having been given to causes and degree of deterioration and actual shrinkage as influenced by moisture content, soundness, and climatic conditions. It has been determined that

excessive moisture is the most dangerous factor in handling commercial grain and that the artificial drying of corn increases its keeping qualities. Milling and baking investigations and grain-dockage investigations have been prosecuted vigorously.

Among the most important experiments being carried on at this time are tests to determine the effect on grade and the commercial and feeding values resulting from the artificial bleaching or "sulphuring" of oats. Satisfactory cooperation with grain-carrying railroads, commercial grain exchanges, grain dealers' associations, grain elevator companies, etc., has been had throughout the year, and this has contributed largely to the success of the work.

Since the organization of this investigation in 1906 an enormous amount of work has been done, including many special experiments and the testing of approximately 100,000 samples of grain. On arrival at European ports 183 cargoes of American corn have been examined, and the results of the examinations have been published, while 9 cargoes of export grain have been accompanied from the United States to foreign ports and observations and tests made of them. Sufficient data are now available to establish standard grades for corn.

#### DEVELOPMENT OF THE BEET-SUGAR INDUSTRY.

The beet-sugar industry has practically grown up during the period covered by this report. There are now in operation 66 factories in 17 States, which required and used for the past season 5,062,333 tons of beets from 473,877 acres. It is estimated that the output of sugar from these factories the present year will be close to 700,000 tons, the largest yield in the history of the industry in this country.

The department has demonstrated the applicability of the American soil and climate to this crop and has shown the benefits that have accrued to our agriculture from its establishment. The most favorable localities have been pointed out, the growers given instructions for caring for their beets, and the general progress of the industry fostered.

The diseases of the sugar beet have been studied and the causes of a number of them have been worked out and satisfactory remedies suggested.

The production of American sugar-beet seed has been an aim of the department for years. It has been demonstrated that seed of good quality can be produced here, American strains have been bred, and the commercial production of beet seed is now in sight. In connection with this work field laboratories have been established with analytical and other facilities and experiments with cultural methods have been carried on, particularly in the irrigated districts of the West.

Much has been done to improve farm practices there and to put beet culture on a permanent and rational basis. In conclusion, it is safe to say that the beet-sugar industry is now one of the mainstays and chief supports of agriculture under irrigation in this country.

#### PROGRESS IN PLANT PHYSIOLOGY AND PATHOLOGY.

As indicated at the outset of this statement regarding the work of the Bureau of Plant Industry, one of the fundamental lines of work which the present Secretary had in mind was a study of the diseases of crops, with a view to outlining specific remedies for the same. Much progress has been made in this work not only so far as the department is concerned but throughout the country as a whole. The plant pathological work of the department is now on a firm foundation. Our leading pathologists have developed lines of work which have been epoch making in their nature.

#### PROBLEMS IN PLANT PATHOLOGY.

The cause of the crown-gall of plants has been determined, and it has been discovered that this disease resembles animal cancer in its manner of growth and is due to bacteria lodged inside certain of the proliferating cells.

It has been proved that infection of Stewart's bacterial disease of sweet corn is produced by means of seed corn; that the black rot of crucifers, the brown rot of potatoes, the wilt of cucurbits, and other bacterial diseases are distributed by insects and slugs; that tobacco wilt is spread by nematodes; that bacterial infection can take place through stomata in the absence of wounds, as in the case of the black spot of plum, a disease of sweet corn and broom corn, and other plant diseases; that acid canes are resistant to the bacterial disease of sugar cane; that many bacteria, including *Bacillus typhosus*, are readily destroyed by freezing; that the Granville tobacco wilt is identical with the bacterial brown rot of potato, eggplant, and tomato, and hence these plants should not be used in rotation.

The cause and remedy of the olive tubercle disease, coconut bud rot, bacterial mulberry blight, and a new knot disease of citrus trees have been discovered.

It has been shown that the cause of a large part of potato rot is due to *Bacillus phytophthorus*, and that the rot is arrested in tubers stored below 8° C.

#### FOREST PATHOLOGY.

A general pathological survey of the National Forests has been made as a preliminary to active investigational work. Extensive experiments have been inaugurated for controlling forest diseases by the improvement of forest hygiene, chiefly by the method of

eliminating trees affected with dangerous diseases at the time of timber sales.

Very valuable results have been secured in the control of diseases of forest nursery stock. The leaf blight of young conifers has been shown to be readily controlled by slight modifications of prevailing nursery practice, particularly in connection with irrigation. The damping-off of forest-tree seedlings has been controlled by the use of soil fungicides, particularly by sulphuric acid. The white-pine blister rust has been destroyed wherever found, and the work on this disease has been largely responsible for the passage of the present plant quarantine act, which should prevent its further introduction.

Cooperation is in effect with 11 States in the investigation and control of the chestnut-tree bark disease, the most destructive of all tree diseases, and the work of checking its progress through methods worked out by this department is being vigorously prosecuted.

One important branch of the forest pathological work is the study and control of the diseases of shade and ornamental trees and shrubs. There is a great and growing demand from the general public for information in regard to such diseases.

#### DISEASES OF FRUITS.

The effective control of pear blight, one of the most serious diseases affecting pomaceous fruits, has been accomplished through eradication methods and has resulted in the saving of millions of dollars to pear orchardists on the Pacific coast and in other parts of the country.

Apple bitter-rot, a disease which has been responsible for immense losses to apple growers, has been shown to be easily and completely controlled by proper spraying with Bordeaux mixture.

A number of other apple diseases, such as scab, leaf-spot, powdery mildew, and blotch, have also been successfully controlled by spraying. Partial control of apple cedar-rust has been accomplished by cutting down the cedars and by spraying.

With the exception of bitter-rot, it has been found preferable to spray for the early treatments of apple diseases with lime-sulphur solution, using Bordeaux mixture for the later treatments. This practice has resulted in less russetting of apples from copper poisoning and has not reduced the effectiveness of the treatment.

Investigations have been carried on in connection with a number of physiological diseases of fruits, particularly of the apple, including apple bitter-pit, a disease producing corky spots in the Ben Davis and York Imperial apples, and the Jonathan fruit-spot. In the latter the trouble has been remedied by early picking and prompt storage.



The problem in connection with peach diseases has been to find a spray solution that would not injure the peach foliage. This has been brought about by the discovery of the self-boiled lime-sulphur solution, which has been demonstrated to be an effective remedy for the control of the destructive brown-rot and also of peach scab. A disastrous blight of peaches in California, due to a gumming fungus, has also been brought under control by late fall or early winter spraying with fungicides.

A number of serious fungous diseases of the cranberry have been investigated and effective methods of control devised. A satisfactory method for the treatment of grape anthracnose, a very destructive malady of both fruit and vine, has been demonstrated, and a remedy for black-rot perfected. Among the nut diseases, a remedy for pecan scab by spraying has been worked out.

A serious contagious disease belonging to the peach-yellows group, known as "little peach," has been discovered and described and a practical method of control by eradication developed. This was at one time a dangerous disease in the Michigan, New York, and New Jersey peach belts.

The fruit pathological work has been strengthened through the institution of thorough, systematic spraying demonstrations in orchards and vineyards in various parts of the country. In this manner methods of treatment of fruit diseases have been brought home to the farmer and the value of our research discoveries has been greatly increased.

#### DISEASES OF COTTON, TRUCK CROPS, AND SUGAR BEETS.

The cause of a group of destructive wilt diseases of cotton, cow-pea, watermelon, tomato, and other plants in the Southern States has been found to be root and stem infecting fungi (*Fusarium* spp.) and a practicable method of control developed through selection and the breeding of disease-resistant varieties.

Advances have been made in our knowledge of the cause and control of a number of potato diseases, the most serious of which is potato wilt, causing premature ripening followed by dry-rot in storage. Methods of treatment for blackleg and early and late blight have also been determined, and the cause ascertained of leaf-roll, a destructive disease of potatoes in the West.

The asparagus-rust problem has been solved by breeding resistant varieties. Truck growers have been shown, by spraying demonstrations, how to control the destructive blights of cucumbers, cantaloupes, celery, and other crops, and how to manage their soils to escape malnutrition troubles and at the same time to produce more crops with less fertilizer. A general investigation has been made of dry-rot, stem-rot, and other diseases of sweet potatoes, and remedial measures have been recommended. Tobacco root-rot,

tomato wilt and rot, a number of ginseng diseases, and the whole group of nematode diseases have been studied critically and control measures introduced.

Leaf-spot and curly-top, two important diseases of sugar beets, have been thoroughly investigated, and better methods for combating them have been pointed out. Similar work has been done in connection with the damping-off and root-rot of sugar beets.

#### SOIL-BACTERIOLOGY AND PLANT-NUTRITION INVESTIGATIONS.

Satisfactory methods for isolating and distributing nitrogen-fixing bacteria for improving leguminous crops by inoculating the seed or the soil were discovered. Tests in cooperation with thousands of farmers throughout the United States have shown that such crops as clover, alfalfa, vetch, peas, and beans are often doubled or trebled in value by pure-culture inoculation. During the past five years the efficiency of the cultures distributed to farmers has been approximately 75 per cent.

The copper-sulphate method for destroying objectionable algae in city water supplies without lowering the safety of the supply has been discovered and practically demonstrated. This method has become standard practice in sanitary engineering and is recommended by the leading sanitary experts. It was found that copper sulphate could be used in water supplies as an agent for killing dangerous germs, such as those causing cholera and typhoid. Simple directions for improving farm water supplies have also been formulated.

Extensive bacteriological studies to explain the variation in soil fertility have been undertaken, and during the past year the classical ideas regarding the decomposition of cellulose, which is considered a fundamental substance in humus formation, have been found to be erroneous. Many new and important species of soil bacteria that dissolve cellulose are under investigation, which are expected to make possible more suitable farm practices for maintaining soil humus.

#### WORK ON DRUG PLANTS.

It has been shown that many valuable drug and related crops can be successfully grown in favorable regions throughout the country. The culture of golden-seal and paprika peppers has been successfully established. Camphor culture has been introduced in Florida, with results sufficiently promising to attract private capital on an extensive scale.

The culture of American tea has been introduced in a demonstration experiment now yielding an annual crop of 14,000 to 16,000 pounds of high-grade tea, all of which finds a ready market in competition with imported teas.

Hop investigations have been productive of valuable results in demonstrating the causes of failure to produce the best returns in yield and quality, and have also led to the recommendation of rational criteria for judging hops on the basis of their properties and constituents rather than their geographic origin, with the hope of removing certain forms of discrimination now made against American hops in the trade. Improved foreign varieties are being introduced and progress made in the improvement of the yield and quality of American hops.

Studies of oil and perfumery plants have included the planting of 40 varieties of roses of imported types yielding the valuable rose oil of commerce and the development of good commercial values from raisin-seed waste and other oil-yielding residues, as well as from a number of neglected plants. In this connection a new turpentine substitute and a new linseed-oil substitute have been demonstrated.

#### POISONOUS-PLANT STUDIES.

Loco weeds, larkspur, wild lupine, death camas, and other poisonous plants have been responsible for enormous losses of stock in the grazing regions of the West. These losses have been greatly reduced through botanical surveys, and field and laboratory tests of suspected plants, so that it has been possible to point out the harmful plants, to recommend methods of avoiding poisonous-plant areas at the most dangerous period of growth, and to devise and indicate methods of treatment, antidoting, etc.

#### PLANT PHYSIOLOGICAL INVESTIGATIONS.

Advances in agricultural science have necessitated the broadening of the work in physiological investigations to meet the demands for fundamental knowledge of plant activities. The following are some of the results of these studies: An accurate method for measuring the oxidase content of plant juices, which has particular application in determining physiological phenomena accompanying many types of plant diseases; increased knowledge of the physiological conditions affecting the keeping qualities of sweet potatoes in storage and a consequent avoidance of the heavy annual losses from their rapid deterioration; a better understanding of the inorganic food requirements of plants and of the influence on plant development of various ratios of these inorganic constituents; and additional light upon existing confusion as to the toxicity of certain molds occurring in spoiled foods and the harmlessness of others of the same group, as the result of a study of the metabolism of molds and of the conditions under which they elaborate toxic products.

## PROGRESS IN DEMONSTRATION WORK.

## COOPERATIVE DEMONSTRATION WORK IN THE SOUTH.

The demonstration idea has been a feature of the work of the Bureau of Plant Industry since its organization. Even before the plant work was coordinated, demonstrations were a necessary adjunct to research work on plant diseases, notably those of the grape and the potato. Early in 1903 the advent of the cotton boll weevil in the South made it imperative that steps be taken to meet its ravages through some cooperative effort on the part of the farmers.

Out of the various preliminary steps that must necessarily be taken in a work of this nature there developed a few years later the Farmers' Cooperative Demonstration Work. Briefly stated, the object of this work was to bring home to the farmer on his own farm certain fundamentals which would enable him to grow cotton despite the weevil, and also to point the way for him to diversify his crops and build up his land. It was found essential that the farmer should be taught self-reliance and to help himself in so far as related to the practices of the farm. Any effort made to help the farmer by mere object lessons in which he did not actively participate was found to be a failure.

As the work progressed the demand for it rapidly increased. At the close of the fiscal year 1906 there were employed 25 agents having under their supervision more than 2,000 demonstration farms, and in addition more than 3,500 cooperators were receiving instructions from the department. The demand now arose for more intensified work. Each field agent's territory included several counties, and he could at most personally supervise not more than three or four demonstration farms located near the principal railroad centers in each county. In several counties business men and leading farmers now offered to contribute toward the salary of an agent to devote his entire time to their county. In the season of 1907 such cooperative plans were arranged for a county agent in six counties in eastern Texas and two in western Louisiana. The results in such counties were so satisfactory that the county agent was henceforth considered a necessary addition to the plan of organization. Since that time no material change has been made in the plan, which includes a special agent in charge, with a staff of assistants and a clerical force, a State agent, and from two to four district agents in each State, and generally a county or local agent in each county in the State.

It is not too much to say that this work has revolutionized the agriculture of the Southern States. It has given the farmers a new outlook and has shown them the great possibilities of the land. The scope of the work has been gradually enlarged from simple demon-

strations in cotton culture to a comprehensive system of instruction in general agriculture, including the organization of boys' corn clubs and girls' canning clubs.

The extensive growth of this work from its small beginning may be appreciated from the fact that at the end of the fiscal year 1912 the force of agents conducting demonstration work in the field was 858; something like 35,000 farmers were enrolled as demonstrators and about 67,000 additional farmers were listed as cooperators in the department's methods. Enrolled in the boys' corn clubs were approximately 68,000 boys, and in the girls' canning clubs 20,000 girls. From its inception the work has been on a cooperative basis. Merchants and business men supplied seed and fertilizer for the cotton-culture farms, even during the earliest years of the work, and farmers did the work. With the growth of the plan of supplying local or county agents, business men and commercial bodies, in order to secure the services of such local or county agents in their counties, began to assist in paying their salaries. Cooperative relationships have been established with agricultural colleges, boards of agriculture, and county organizations.

The department is now spending something like \$600,000 annually in the work throughout the Southern States, about half of which is appropriated by the Government, while the other half is contributed by State and private agencies. It is believed that the permanency of the demonstration work on the southern farms is assured, as its efficiency has been thoroughly tested under various conditions; it is attracting wide attention, and the plan is being rapidly adopted by agricultural colleges, business organizations, railroads, and other agencies doing propaganda work. Within recent years representatives from many foreign countries have been sent into the South to study the practical workings and efficiency of the system.

#### FARM-MANAGEMENT INVESTIGATIONS.

Early in the development of the work of the Bureau of Plant Industry it was seen that some coordinating agency was necessary to bring together and apply to the individual farm the results of many special lines of investigation under way. Growing out of this need was developed the Office of Farm Management, which was established eight or nine years ago. The work of this office began with a detailed study of the methods and practices actually in use on various farms of the country. Special attention was given to the study of those farms that were most successful for the purpose of comparing them with those less successful, the object being to learn the reason of success in one case and of failure in the other under similar circumstances.

This work, at first more or less general in character, has developed into a detailed study not only of methods and practices generally in use, but also a study of farm organization and the coordination of related enterprises on the farm into such a system as will give the greatest return from the farm. Some of the special lines now in operation are as follows:

**FARM BOOKKEEPING.**—Because of the importance of adequate methods of keeping the accounts of the farm a great deal of attention has been given to this subject. The results to date have just been published in Farmers' Bulletin 511, entitled "Farm Bookkeeping."

**COST ACCOUNTING.**—This is a study of the actual cost of operations on the farm and over 100 farms are now cooperating in keeping the actual time spent in the smallest details of every operation performed on the farm.

**FARM-MANAGEMENT SURVEYS.**—Farm to farm surveys of typical agricultural areas are being made to determine what returns are being received for capital and labor on the average farm of each type. At the present time the records of about 4,000 farms have been gathered, some of which have already been published, while others are being tabulated and prepared for publication.

**FARM EQUIPMENT.**—A detailed study of the equipment of the farm is being made on a large number of farms for the purpose of learning what is an adequate equipment for farms of various types.

#### FARM-MANAGEMENT FIELD STUDIES AND DEMONSTRATIONS.

The result of the investigations of the past few years is that a vast fund of information has accumulated which the farmer needs and which he is entitled to have. The means of getting this information to the farmer in such a way that everyone may understand it has been the cause of considerable thought on the part of those who have charge of the work. Bulletins have been issued, but for various reasons failed to reach the farmers as effectively as had been hoped. Later, demonstration farms were established with a view to bringing into each community as an object lesson a farm properly equipped and managed. This plan also fell short of what was expected of it. Later, the plan of placing in each county or local area agricultural agents, whose services would be free to every farmer in the locality, has been established and is rapidly developing. The duties of the county agent are as follows:

- To acquaint himself as rapidly as possible with the general agricultural conditions of the locality, study the various types of soils, the crops that have been found to be best adapted, and the types of farming that have been most successful on each type of soil.

To spend his entire time in the interests of improved farming in the section, studying the methods and practices of the most successful farmers who are following the various types of farming; to visit the farmers on their farms, study their plans, and aid them in formulating better plans.

To study every phase of all the farms he visits, so that he may know what methods, crops, and systems are best for the locality, and at all times, wherever he goes, to give the farmers the benefit of the information he gets, including the results of scientific investigations conducted by the various experiment stations and the United States Department of Agriculture relating to all kinds of farm practice.

The first of these county agencies was established in Bedford County, Pa., three years ago. Agricultural conditions were at a low ebb. Reports for the past season show that 8,000 acres of corn have been grown by improved cultural methods and the use of selected seed, with an average increased yield of 5 bushels per acre; 6,400 acres of clover from inoculated northern seed; 1,500 acres of soy beans, a crop wholly unknown before this work started; 200 acres of rape for hog pasture, replacing either grass pasture or none; and 300 acres of alfalfa. No attention had ever been given to the apple crop before this work began. The orchards were neglected. Now the trees are being pruned and sprayed under the agent's direction, and the fruit is carefully graded, packed, and shipped under label. This affords an instance of where a latent industry may be developed under this plan. The value of the results of improved methods in this county for the past season is not less than \$135,000.

The next county agent was located in Broome County, N. Y. In this case the Binghamton Chamber of Commerce and the Delaware, Lackawanna & Western Railroad are cooperating financially toward the work, which is directed jointly by the New York State College of Agriculture and this department.

This method of cooperation with business organizations has met with general approval, and the demand for this work is far beyond the ability of the department to meet. At the last session of Congress \$300,000 was appropriated for this work. There are now about 75 county agents in various parts of the country, and others will be established as fast as means and competent men can be had.

The methods of cooperation here mentioned are similar to many that have since been established. In every case the work in the State is conducted in cooperation with the agricultural college or experiment station, either with or without aid from other organizations.

#### ENTOMOLOGY.

##### EXTRAORDINARY GROWTH OF SERVICE.

Sixteen years ago the entomological service of the department was ranked as a division, and it had on its rolls 21 employees; the statu-

tory roll amounted to \$9,500 per annum, and the lump fund to be spent for investigations was \$20,000.

At the present time the service ranks as a bureau and carries more than 500 employees upon its rolls. The amount paid for statutory salaries is \$58,750 per annum, and the total annual appropriation is \$672,340.

Sixteen years ago the work was entirely carried on in three or four rooms in the city of Washington; members of the force visited the field from time to time, but there were no field stations.

At the present time the bulk of the work is done far away from Washington. The bureau has 35 field laboratories scattered all over the United States, and nearly all of them admirably fitted for sound investigation work upon certain particular insects or groups of insects most advantageously to be studied at the individual stations.

It may reasonably be supposed that the extraordinary growth of the service, just as with other branches of the department, has been facilitated by Congress upon recognition of the practical results achieved by the work which has been done. Some of the good work carried on may be mentioned briefly.

#### IMPORTATIONS OF INJURIOUS INSECTS.

Just 16 years ago the bureau began to study with extreme care the question of the accidental introduction, by means of commerce, of injurious insects from other countries. It was realized that about one-half of the injurious species of first-class importance had been so introduced, and in consequence not only was begun the study of other species likely to be imported, but a quarantine and inspection bill was drafted and put before Congress from time to time from 1897 down to the Congress of the winter of 1911-12. Passage of an act of this character was warmly urged by the department during all those years, and the passage of such a law by the last Congress is a measure which will undoubtedly prove of great benefit to the country.

#### SAN JOSE SCALE.

During the early part of this 16-year period the San Jose scale, which had recently made its appearance in the East and threatened the destruction of eastern orchards, was carefully investigated by the bureau, and its final report on the life history of this destructive scale has remained as a standard. Later the country of origin was discovered by an employee of the bureau, Mr. Marlatt, and from that country (China) he sent over a predatory enemy of the scale, which was reared in confinement at Washington and subsequently liberated in orchards in different parts of the country.



It is true that the success of the lime-sulphur wash as a winter treatment for this scale has obviated the necessity for a competent natural enemy to a large extent, but it is believed that this enemy is still living in parts of the South.

#### MEXICAN COTTON BOLL WEEVIL.

The Mexican cotton boll weevil received some attention at the hands of the department prior to the 16-year period under consideration. At that time it was confined to the State of Texas, and, inasmuch as the State itself appropriated a sum of money for its investigation, to be carried on by the State entomologist, the department turned the matter over to the station authorities for a time.

In 1900, however, it appeared that the problem was so great as to demand every possible aid, and, with congressional appropriations, the entomological service of the department entered once more upon the investigation and has continued it until the present time. In the course of this investigation probably the most intensive study ever made has been carried out in regard to the boll weevil. Every phase of its life history and activities has been gone into with the utmost particularity.

As the result of these intensive studies, while no actual and radical remedy of an exterminative character has been found, a system of cotton-plantation management has been developed, based entirely on these studies, which enables the planter to grow good crops even in the presence of the weevil. This has been put into effect with great success by the southern farm demonstration service of the Bureau of Plant Industry. Incidentally other insect enemies of cotton have been studied during these investigations.

#### FIG WASP.

Following the sending to California from Algeria by Mr. Swingle, of the Bureau of Plant Industry, of the fig wasp (*Blastophaga grossorum*), this insect, upon whose relations with the flowers of the Smyrna fig the production of the Smyrna fig crop is dependent, was established in California under the management of an agent of the Bureau of Entomology, and this establishment is responsible for the present Smyrna fig culture in that State and of its future culture in other States.

#### GIPSY MOTH AND BROWN-TAIL MOTH.

The gipsy moth and the brown-tail moth, two insects accidentally introduced into New England, became so abundant and destructive in 1905 as to call not only for large State appropriations but for governmental aid. Realizing the hopelessness of exterminative work after these pests had gained a firm foothold over 4,000 square miles

of territory, Congress appropriated to the department a sum of money to be used in the effort to prevent the spread of both gipsy moth and brown-tail moth.

During the years in which this appropriation has been made, the bureau and the different States acting in cooperation have succeeded in preventing any extensive spread and in making the conditions of the towns and villages within the infested territory perfectly livable, whereas previously both species had been enormously destructive and very annoying.

During that period further extensive importations of the parasites and natural enemies of the gipsy moth have been made from Europe and from Japan, and of the brown-tail moth from different parts of Europe. Very many species have been imported in great quantities, and a number of them have been established in New England territory. The effect of their work is being more strongly seen each year, and it is hoped that they will shortly become so numerous as to be important factors in holding the destructive insects in check.

Recent discoveries have been made which promise, by observing certain principles in forest management, to result in the preservation of good stands of timber in the New England forests in spite of the continued presence of these tree pests.

#### OTHER NOXIOUS INSECTS.

The introduction of the parasites and natural enemies of the gipsy moth and brown-tail moth is not the only work of this kind done by the bureau. An important enemy of the black scale of the orange and olive has been introduced, an egg parasite of the elm-leaf beetle as well, and at present the bureau is engaged in importing the European parasites of the alfalfa weevil. Similar shipments of American parasites to foreign Governments have also been made, and the most striking success has been achieved in the sending of a minute parasite of the mulberry scale from the United States to Italy, where it is reported to have been of the greatest benefit in the destruction of the scales, which bred so numerously in the mulberry plantations as to threaten the entire destruction of this tree upon which is based the great silk-growing industry of that country.

A few years ago a thrips appeared upon pear trees and other deciduous fruit trees in central California, completely blasting the crops and spreading rapidly, threatening the destruction of practically all deciduous fruits on the Pacific coast. After two years' investigation of the method of life of this pest, the bureau discovered perfectly competent remedies, by the use of which orchardists are once more growing their normal crops.

Three years ago a weevil destructive to the alfalfa was discovered in the vicinity of Salt Lake City. It has spread rather rapidly

to the north and to the east, and appeared to threaten great danger to this vitally important crop of the irrigated regions of the West. The bureau's experts have been studying it since the beginning, have been engaged in importing its natural enemies from Europe (it is a European insect), and have now discovered a method by which the pest can be handled after the first crop of alfalfa has been harvested. It is hoped that in time some other means will be discovered whereby the important first crop can be saved.

#### INSECTS AS CARRIERS OF DISEASES.

Throughout the entire 16 years the important subject of the carriage of diseases of man and animals by insects has been investigated. The mosquitoes that carry malaria and yellow fever have been carefully studied, and publications have been issued warning people and giving remedies.

In the same way the relation of the common house fly to the carriage of typhoid fever and other intestinal diseases has been studied, and in the same way publications of warning have been issued, and these have given remedies.

The tick which carries the Rocky Mountain spotted fever has also been studied, and an investigation has been completed which points out a way to control this dangerous creature.

The ticks that carry the Texas fever of cattle have also been made the subject of intensive study, and many facts have been ascertained which are of service to the Bureau of Animal Industry in its large-scale work in pushing the quarantine line against southern cattle farther and farther to the south.

#### FUMIGATING CITRUS TREES.

The process of fumigating citrus trees with hydrocyanic-acid gas, which was carried on at a very great expense by the prosperous owners of citrus groves in southern California a few years ago, has been studied with the utmost care, and as a result the expense of the process has been reduced to a remarkable degree. A single grower has stated that the result of this work has saved him a quarter of a million dollars.

#### INSECTS INJURIOUS TO TREES.

Facts determined within the past 10 years indicate quite conclusively that 7 species of bark beetles of the genus *Dendroctonus*, injurious to coniferous trees, have killed more merchantable pine, spruce, and Douglas fir timber in this country than has been killed in the same period by forest fires. Investigations by the bureau have resulted in the gaining of a very complete knowledge of these injurious species and in ascertaining methods of control. The success of

these methods of control has been demonstrated many times. Extensive depredations in Colorado, South Dakota, Montana, Oregon, and California by one of these beetles have been successfully controlled in localities where cooperative demonstration work has been carried on at a cost conforming to profitable business methods.

In 1910 and 1911 an outbreak of the southern pine beetle, which 20 years before had devastated the pine forests of West Virginia and Virginia, threatened a like fate to the pine timber of the South Atlantic and Gulf States, but practical demonstrations by representatives of the bureau and the adoption by the owners of the timber of the methods recommended resulted in the cutting of millions of cords of wood from the infested trees, which was burned for fuel, thus destroying the broods of the beetles in the bark. This has contributed to the almost complete control of the beetle and to the saving of one of the principal natural resources of the South.

The officials of Federal, State, municipal, and private reservations, as well as private owners of forest and wood lots, are beginning to avail themselves of this information, so that, as a direct result of the investigations of the department, these beetles will be eliminated as an important factor in forest destruction.

#### DEMONSTRATION WORK.

Demonstration work, such as is mentioned in the previous paragraph, has come to be an important function of the bureau, and such work has been carried on against the codling moth in different parts of the country, against the pear thrips in California, against the grape rootworm in Pennsylvania, against the cotton boll weevil in Texas, against the cattle tick in Texas, against the plum curculio in Georgia, and against other insects in other parts of the country. There seems to be a great difference between the results of telling people how to do things and showing them how to do them.

#### COOPERATION WITH OTHER AGENCIES.

In the course of the work there has been much cooperation with State experiment stations and with other organizations. For example, the bureau has cooperated with Massachusetts in the work on the gipsy moth parasites, in the general moth work, and in the inspection work; with Montana on the spotted fever, with Louisiana on the Argentine ant, with Texas on cotton insects other than the boll weevil, with California on the subject of scale parasites, with Tennessee on tobacco insects, with South Carolina on the red spider and other cotton insects, with Indiana and Kansas on forage-crop insects; with Utah on the alfalfa weevil, with Hawaii on the Mediterranean fruit-fly, with Wisconsin on cranberry insects, and with many others.

## LIFE HISTORIES OF INSECTS.

During the 16 years the complete life histories of many hundreds of species of injurious insects have been worked out, and the publications of the service during that period cover in competent form practically all of the principal crop pests of the United States.

## SOIL INVESTIGATIONS.

## FEARS OF SOIL EXHAUSTION.

For the fiscal year 1897 there was appropriated for the Division of Soils \$15,300, while for the year 1912 the appropriation for the Bureau of Soils was \$262,060. In the former period the work was 3 years old, and the foundation for subsequent development was still being laid.

For 60 years the scientists of the world had wrestled with Liebig's mineral theory of plant food without progressing much beyond the limits of his classical work. No practical or efficient basis of classification of soils had been worked out, the adaptation of crops to soils was not appreciated, there was no rational theory of fertilization, no specific knowledge of how fertilizers act upon the soil or plant, and no efficient methods of determining the manurial requirements of a soil.

Moreover, our people have always been an adventurous people; the country sparsely settled and new in experience and tradition. Methods of culture and crop rotation adapted to the different soils were little understood or considered of minor importance. The impression was general that the soils of the country were wearing out with ever-decreasing productivity, and alarm was felt for the future of our increasing population and the possibility of the ultimate exhaustion of our soils and of the natural deposits of fertilizer materials, which it was claimed were essential for the maintenance of the proper mineral composition of agricultural lands.

These are subjects that are at the very foundation of the Nation's prosperity, and are matters that I have had deeply at heart during my term of service.

## THE SOIL AN INDESTRUCTIBLE ASSET.

As a result of the profound investigation in the Bureau of Soils of reported cases of soil exhaustion, it appears that all such cases are due principally to mismanagement of tillage operations, to the lack of proper adaptation of soils and crops, to the unwise rotation of crops, and to the misuse of fertilizers and manures, making it a personal failure rather than a natural and fundamental deterioration of the soil. It can be said, therefore, that the soil is the one inde-

structible asset of the Nation, which can be vastly improved by better and intensive methods or which can be temporarily impaired by wrong usage.

This conclusion was reached through a mineralogical study of soils and rocks, the study of the solubility of soil minerals and of the composition of the soil solution, the study of the profound changes taking place in the soil constantly through the mixing of soil grains by erosion, winds, and internal movements, and in the soil constituents through the action of percolating and capillary waters, the study of the increasing yield of farm crops during the 40 years for which records have been kept in this country, a study of the much larger increases in yields on the older soils of Europe during the past 300 years, and by a comparison of the chemical composition of the relatively new soils of this country and the relatively older agricultural soils of Europe.

#### SOIL SURVEYS.

Admitting that the productivity of our many important soils depends in the long run upon the knowledge and skill of our people in handling each type according to its specific needs, the importance and significance of the bureau's work in the classification and mapping of soils can be more fully appreciated.

During the last 12 years soil surveys have been made of 622,595 square miles, or an area practically as large as the combined areas of Germany, France, Great Britain, Ireland, and Italy. In this work the soils are classified according to their origin and constitution, and the reports discuss their characteristics, their principal tillage requirements, and their crop adaptations. Omitting the sparsely settled Rocky Mountain region, the Northwest Intermountain region, the arid Southwest, and the Great Basin, the survey has covered 29.2 per cent of the land surface of the United States, giving a complete classification of the soils, showing their area and distribution within the limits of the surveys, and indicating in a general way the localities outside of the areas surveyed where the different soil types may be expected to be found.

#### ADAPTATION OF SOILS.

During the progress of this work and through supplemental investigations, the special adaptation of many of these types of soils to crops has been worked out, and we have definitely established the cause of many failures in farming to be the attempt to produce crops on soils to which they are not adapted and upon which a high degree of commercial success can not be expected.

Conversely, we have a knowledge of soils that are peculiarly adapted to certain crops and others which should be used for certain crops when increasing density of population and market and transportation facilities justify their most intensive use.

Examples of such knowledge acquired through the soil survey might be multiplied indefinitely. As a result of the soil survey of the Connecticut Valley in 1899, possibilities of introducing the Sumatra type of tobacco wrapper leaf were pointed out on certain soils of that locality, and since then an industry has been established where a very fine textured leaf is produced, under the most intensive cultivation, which sells for as much as \$2 a pound, as against 20 to 30 cents a pound for the leaf previously grown, and the industry has now become one of considerable magnitude and importance.

In the soil of the Nacogdoches area, Texas, the similarity of certain soils there with the soils of the Vuelta Abajo district of Cuba was noticed, and as a result of field experiments put out by the bureau it was found that the Cuban tobacco seed produced on certain types of soils the fine aroma of the leaf grown in Cuba.

#### MALADAPTATION.

The soil survey has shown that not over 5 per cent of the soils adapted to winter and spring vegetables are now being devoted to these valuable crops, the remaining 95 per cent being little used, as they have little value for general farm crops and are not needed at present for the crops for which they are adapted.

In the development of this industry in the future there will be no excuse for the mistakes that have been made in the past, as the relation of every type of truck soil to the variety of truck crop to which it is best adapted is now well understood, and the location of these soil types is known.

Similarly, the vast opportunities for the safe development of fruit and of dairy industries so far as they are dependent upon the soil and climatic conditions and cultural treatment are now assured, if one but takes advantage of the work that has been done by the Department of Agriculture.

The much-dreaded injury from alkali in the soils of the dry regions of the West no longer need exist, as the Bureau of Soils has located and accurately mapped the alkali soils, so far as they have been encountered in the survey, has studied the type of alkali in each district, and has shown that it can be controlled and eliminated from serious consideration by practicable methods of soil management.

Through laboratory research it has been found that not only do soil types differ in their relation to crops but that they differ also in

the effect left by these crops which influences succeeding crops, and that for the highest development of the soil crops must succeed crops in a certain general order, which order of rotation is dependent upon the nature of the soil as well as upon climatic conditions and cultural treatment.

#### COMMERCIAL FERTILIZERS.

The subject of the use of commercial fertilizers, which has developed to so large proportions in the last 50 years, has also been investigated by the bureau, and it has been found that they have very important functions in addition to their value as mineral plant foods.

The soil is not static, as was formerly supposed, but is dynamic, with many functions continually at work producing changes and always mutually affecting one another, and these changes can also be profoundly influenced by the substances ordinarily used as soil amendments.

It has further been shown that the United States has within its borders ample supplies of the raw materials which experience has proved to be most useful as fertilizers to supply the Nation's needs for an indefinite period into the future.

There is in this country enough high-grade phosphate rock to supply three times the present demands for 12 centuries or more. The giant kelps of the Pacific coast and Alaska, if properly conserved and cropped on scientific principles, can probably surpass in yield of potash salts the famous Stassfurt mines, and there is reason to expect that commercial production of potash from feldspar will soon be a reality. With many sources of nitrogen carriers yet to be utilized to their fullest extent and with practicable methods of "fixing" atmospheric nitrogen already finding a home in this country, the future may be faced with equanimity so far as problems of supply are concerned.

All of the results of fertilizer experiments that have been made and published in this country have been summarized in a series of bulletins, which, together with the laboratory investigations now going on, will ultimately, it is believed, lay the foundation for a rational system of fertilization.

#### FUTURE PRODUCTIVITY.

With intelligence and care in the cultivation of the lands already under agricultural occupation and in the taking up of idle lands with increasing density of population, it is estimated that the soils of this country will be in about the same state of development as the soils of France and Germany, and that they will produce many times as much as they do to-day.



**ANIMAL INDUSTRY.****MANY NEW LINES OF WORK.**

The work relating to the live-stock industry, which includes not only fostering the interests of those engaged in production but helping the consumers of the country to obtain a supply of wholesome animal food, such as meat, milk, and eggs, has been greatly enlarged during the 16 years under review. Prior to 1897 the work of the Bureau of Animal Industry related almost entirely to diseases of animals, meat inspection, etc., and very scant attention was given to such important things as animal husbandry and dairying.

**ANIMAL HUSBANDRY.****BEGINNINGS.**

Animal husbandry as a separate branch of the Bureau of Animal Industry at Washington was first recognized on July 1, 1901, when an expert in animal husbandry was appointed. In 1904 a specific appropriation for such work was requested, and Congress appropriated \$25,000 for cooperative experiments in animal feeding and breeding, to be spent during the fiscal year 1905. The animal husbandry work began to be informally designated the "Animal Husbandry Office" about this time, and was formally designated the "Animal Husbandry Division" by the Secretary's order on January 1, 1910.

**HORSE BREEDING.**

The Animal Husbandry Division started the revival of interest in the breeding of Morgan horses. In cooperation with the Colorado Experiment Station the division is demonstrating that the utility characteristics of the American trotter, to which frequent attention has been called by show-ring performances, can be perpetuated by proper selection.

It has brought about a complete reversal in the procedure of importing animals into the United States for breeding purposes, and now a man in the horse-importing business must not only import a pedigree certificate, but a horse as well whose description agrees with that outlined in the certificate.

**INFERTILE EGGS.**

It has shown that by producing infertile eggs the keeping quality of eggs can be greatly improved and millions of dollars in losses from bad eggs can be saved. At its instigation and with the cordial cooperation of local authorities, the egg trade of Kansas was placed on a quality basis in a single year. Other States have followed the example set in Kansas.

## BEEF PRODUCTION IN THE SOUTH.

In cooperation with the Alabama Experiment Station it is being demonstrated that beef can be produced cheaply in the South. The results of eight years' investigation show that the South, east of the Mississippi River, is the territory to which the people of the United States must look in future for reasonably cheap beef.

## SHEEP.

In Wyoming sheep husbandry is being studied to determine the most profitable types and lines of breeding on the range. In Vermont a Southdown flock of high quality is kept.

## ANIMAL NUTRITION.

In cooperation with the Pennsylvania State College the most complete apparatus in the world has been built for the study of the nutrition of domestic animals. The beginning of this work antedates by three years the inauguration of animal husbandry work at Washington.

## MILITARY HORSES.

In the current appropriations act, for the first time in the history of the United States, Congress has recognized the fact that to insure a sufficient supply of suitable horses for military purposes Government aid is necessary. The Government proposes to furnish the stallions but the farmers will breed the remounts. Work will begin without delay, and American farmers will therefore have a share in the national defense.

## WORK RELATING TO THE DAIRY INDUSTRY.

The Dairy Division of the Bureau of Animal Industry was organized July 1, 1895, with four employees, and up to 1897 its work consisted of compiling and publishing data relative to conditions of the dairy industry and the methods most approved at that time. All the experimental and extension work has been done since March, 1897.

## EXPORT BUTTER.

In 1897 experimental shipments of butter to foreign markets were begun. For several years the development of foreign markets for dairy products in Europe, West Indies, and Asia constituted a large part of the division's activity.

## INCREASING THE PRODUCTION OF MILK AND BUTTER FAT.

Census figures show that the average production of milk and butter fat per cow in the United States is entirely too low. A large

proportion of the cows do not produce enough to pay for their feed at market prices. By better selection of cows and better methods of feeding it is possible to increase considerably the average production, which would mean not only the placing of dairy farming on a profitable basis but a more plentiful supply of an important class of food products. Work in this direction has been carried on for several years, and the results are becoming apparent.

#### DAIRYING IN THE SOUTH AND FAR WEST.

Field work for the development and improvement of dairy farming was begun in 1905 with a survey of conditions in the South. That section then had scarcely any dairying, but stood in urgent need of its beneficial effects. Cooperative relations were entered into with State authorities and field work has been carried on in Alabama, Mississippi, Tennessee, North Carolina, South Carolina, Georgia, Kentucky, Maryland, Virginia, Louisiana, and Texas. The people and authorities of the States have become very much interested and are now bearing a large part of the expenses of the work. Dairying has now come to be of considerable importance. Wherever one farmer has been induced to adopt improved equipment and methods the influence of his example has spread in all the surrounding community.

In 1910 similar work was taken up in the Far West in regions where dairying is an entirely new business—beef cattle, sheep, and wheat growing having hitherto received the chief consideration. Field men are at work in Colorado, Idaho, North Dakota, and Utah.

#### COW-TESTING ASSOCIATIONS.

Cow-testing associations, or cooperative clubs for recording the feed and production of the individual cows, are an important means of bringing about increased production of milk and butter fat, and for the past five years work has been carried on for the promotion of these associations. The associations organized number 118, of which 97 are active, with 39,000 cows tested yearly. The records of a Michigan association show that in four years there has been a marked increase in the average production of milk and butter fat per cow, while the average annual profit has been practically doubled.

Another promising line of work just started is the organization of bull associations, or clubs for the cooperative purchase and use of carefully selected purebred bulls, with a view to improving the breeding of dairy herds.

Much investigational work has been conducted with barns, silos, and feeds. The introduction of the popular concrete silo is largely the work of the Dairy Division.

## MARKET MILK.

Work for the improvement of market milk was undertaken in 1905. Attention at first was given only to the sanitary aspects of dairy-farm conditions. Later the product was followed all the way to the city, even into the consumer's ice box, and attention is now being given also to the economics of the subject. A great factor in milk improvement has been the introduction of the score-card system of inspection. Under this system dairy farms, city milk plants, grocery stores, and even the milk and cream are graded according to a numerical valuation of the various elements involved, the total of the score card giving a good comparative idea of the place or thing scored. At the present time over 170 cities are using a score card for inspection, and the milk supply of 22,000,000 people is thereby safeguarded. The efficiency of official inspection has been greatly enhanced, infant mortality has been reduced, and adult health has been bettered. The score card has been translated into French for use in Canada.

This work for the improvement of the milk supply is done largely in cooperation with State dairy commissioners and State and city boards of health. These agencies look to the department for leadership, expert advice, and up-to-date information.

Beginning in 1908 competitive exhibitions of milk and cream have been held under the auspices of the Dairy Division in various cities. Samples are exhibited and scored, and lectures and addresses are given. These exhibitions have educated both dairymen and consumers.

## CREAMERIES AND CHEESE FACTORIES.

Manufacturing enterprises such as creameries and cheese factories are an important part of the dairy industry and have received special attention during the past six years. This work consists of investigations, demonstrations, and cooperative work in the organization and management of creameries and cheese factories, including market conditions and methods, sanitary condition of creameries, and quality of cream; investigations in the manufacture of ice cream, condensed milk, and desiccated milk; and the inspection of renovated-butter factories and materials.

Demonstration work in creamery management is done under the supervision of expert creamery operators, who take temporary charge of creameries and show how to organize properly the routine work and apply improved methods of management. It is expected that this work will result in showing the necessity for more efficient creamery management, also in an improvement in the quantity and quality of butter made. The loss from lack of these things is now estimated at from seven to eight million dollars a year.

## STORED BUTTER.

Great improvement in the quality of stored butter has been made possible by investigations in the manufacture and storage of sweet-cream butter. Butter made from pasteurized sweet cream without the use of a starter, and sealed in tin cans, will keep from 8 to 10 months in storage with but very little deterioration in quality and with practically no development of objectionable flavors, while butter made in the old way from sour, unpasteurized cream is of inferior quality and shows considerable deterioration after storage. These conclusions are based on the results obtained in the manufacture of over 2,000,000 pounds of butter during the last three years.

## QUALITY OF CREAM.

Investigation of the quality of cream used in making creamery butter and the sanitary condition of creameries is expected to reveal the true cause of the poor quality of much of the butter now being made. This work is done by men who are practical creamery operators. They visit the creameries and carefully examine the sanitary conditions. They determine the temperature, acid content, age, and grade of cream and the methods used in its production and care before delivery to the creamery. It has been estimated that less than 10 per cent of the butter made is of first quality, and it seems probable that when the cause is known a remedy may be suggested.

## RENOVATED-BUTTER INSPECTION.

A great deal of butter after becoming rancid is sent to factories to be "renovated" or made fit for food and again placed on the market. Under a law passed in 1902 an inspection of these plants and of their materials and products is maintained. This work has resulted in improving the sanitary condition of the plants making renovated butter, a more careful selection of the materials used, and the proper marking of packages to show that the product is "renovated" or "process" butter, and thus prevents deception of the purchaser. This butter when made under good sanitary conditions and from proper stock is wholesome, though not equal in quality to high-grade creamery butter. When sold on its own merits, its sale is perfectly legitimate.

## LABORATORY WORK ON DAIRY PROBLEMS.

Since 1902 laboratory work on dairy problems has been carried on, and at the present time there are 25 people in the Dairy Division laboratories engaged in research work covering nearly all branches of the dairy industry.

The most notable results so far obtained from the laboratory work are, briefly: The determination of the influence of the breed, the individuality of the animal, and the period of lactation on the composition of the milk; a study of the bacteria surviving pasteurization, and the discovery that certain types of lactic acid bacteria are sufficiently resistant to heat to withstand the temperature of pasteurization, showing that properly pasteurized milk will sour normally; the exact determination of the changes produced in milk by the heat of pasteurization, showing that certain objections to pasteurization are unfounded; the determination of the bacteria and fungi concerned in the ripening of Camembert cheese, and the establishment of methods of making this type of cheese in this country; the discovery that certain types of bacteria hitherto unobserved in Cheddar cheese attain large numbers during the ripening period, and are probably concerned in the production of the flavors; the development of a method whereby cheese of a uniform quality can be made from pasteurized milk; the establishment of the fact that the ordinary off flavors of butter are caused, not by microorganisms, but by spontaneous chemical changes, some of which are induced or accelerated by the acidity of the cream and the presence of iron or copper salts, and in which oxygen inclosed in the butter takes a part. As a result of this latter work it has been demonstrated that butter can be made which will retain its sweet flavor in storage for many months.

Among the new pieces of apparatus developed in the laboratory are one of the first tests for moisture in butter, an improved type of lactometer, a simple butter color standard, a method and apparatus for determining fat in butter, and a humidistat.

#### MEAT INSPECTION.

In 1897 the Government meat inspection was carried on under the law of 1891, which provided only for the inspection of animals before and at the time of slaughter and gave no authority to control sanitation, to supervise the various processes of curing, canning, and preparing meats, or to prevent adulteration or the use of harmful preservatives. The funds available for the inspection were insufficient for carrying on even the ante-mortem and post-mortem inspection at all establishments doing interstate business.

The new law, which was passed in 1906, remedied these defects and increased the powers of the inspectors, and made a permanent annual appropriation of \$3,000,000, so that it may now be truly said that all the different processes in the preparation of meats and meat food products from the "hoof to the can" are carefully supervised by the department and that this inspection and the sanitary condition of the establishments are maintained at a higher standard than that of any other nation.

## STATISTICS OF OPERATIONS.

The number of animals which received Federal inspection at the time of slaughter increased from 26,500,000 in 1897 to over 59,000,000 in 1912. The number of carcasses condemned increased during the same period from 67,000 to over 203,000 and the number of parts of carcasses condemned at slaughter increased from 39,000 to 464,000. In 1907 the inspection was conducted at 128 establishments in 33 cities and towns and in 1912 it covered 847 establishments in 238 cities and towns.

The following data show some of the operations of the Federal meat inspection for the last six years during which the new law has been in effect:

Animals inspected at slaughter, over.....	321, 000, 000
Carcasses condemned, over.....	900, 000
Parts of carcasses condemned, over.....	4, 500, 000
Meat and meat food products:	
Pounds reinspected in their various preparations, over.....	37, 000, 000, 000
Pounds condemned on reinspection, over.....	140, 000, 000
Pounds exported under certificates, over.....	7, 000, 000, 000
Veterinary inspectors and assistants, over.....	2, 400

In addition to the 847 establishments where Federal inspection is continuously maintained, the establishments of more than 2,000 retail butchers and dealers, who hold certificates of exemption that they may make interstate shipments of meats to their customers, are inspected as to sanitary conditions and the wholesomeness of the products they handle.

The high character of the Federal meat inspection has had the effect of greatly stimulating sentiment for the establishment of abattoirs under State or municipal control and for establishing an efficient State or municipal inspection of meats intended for purely local consumption.

## INSPECTION AND QUARANTINE OF IMPORTED ANIMALS.

For many years the department has maintained a system of inspection and quarantine of imported animals for the purpose of protecting the live stock of this country against contagious diseases which prevail in other parts of the world, and which would do tremendous damage if they should gain entrance in this country. In 1897 there were three animal quarantine stations on the Atlantic seaboard, all of which were but poorly equipped and on rented land located near the ports of Boston, New York, and Baltimore.

At present the department has three well-equipped animal quarantine stations for these ports, the land as well as equipment in each case being owned by the Government. Excellent accommodations are provided for animals subject to quarantine.

The present regulations require, in brief, that all horses, cattle, sheep, and other ruminants and swine must be inspected before they are admitted, and, in addition, that all ruminants and swine from any part of the world except North America shall be quarantined. Nearly all the animals admitted on inspection without quarantine come from Canada and Mexico, and consist mainly of cattle and sheep for feeding and slaughter and horses, mules, etc., for work purposes, although some animals from Canada are imported for dairy and breeding purposes. Nearly all the live stock brought from across the seas are pure-bred animals for breeding purposes. During the past five years about a million and a quarter animals have been imported under this system of inspection and quarantine.

#### EXCLUSION OF DISEASES.

Owing to the existence of communicable diseases of animals among the live stock of various parts of the world, importations from overseas have been mainly restricted to Great Britain, Ireland, and the Channel Islands. It is required that a permit be procured from the Secretary of Agriculture prior to the shipment from countries other than North America of cattle, sheep, and other ruminants and swine for their landing subject to inspection and for their detention in quarantine at one of the Federal stations.

During this period of 16 years surra reached our shores in an importation of Brahman cattle from India, but was promptly stamped out in quarantine. Also Malta fever was discovered in a herd of goats from the island of Malta and was likewise eradicated by the slaughter of the affected animals before there was any opportunity for the disease to extend to other animals.

Foot-and-mouth disease has during the above period twice appeared in this country, but has in each instance been promptly eradicated. The infection was introduced in contaminated vaccine imported by manufacturers of biological products, and in neither case was the disease introduced through the medium of products over which this department maintains supervision.

#### INSPECTION OF LIVE STOCK FOR EXPORT.

Animals intended for export are given a veterinary inspection by the Bureau of Animal Industry in order to guard against the exportation of any that may be affected with disease and to conform to the requirements of certain foreign Governments. This inspection thus serves to maintain a good reputation for American live stock in foreign markets and to keep open markets that would otherwise be closed against us.



Our largest exports of cattle are to Great Britain. Considerable numbers of cattle, sheep, horses, and mules are also inspected for export to Canada, and when required by the Canadian regulations the cattle are tested with tuberculin for the detection of tuberculosis, and equine animals with mallein for the detection of glanders.

During the past five years the bureau has made over two and a half million inspections of animals for export. This number includes duplicate inspections of many animals inspected first at interior points, such as Chicago and Buffalo, and again at the ports of export, such as New York and Boston. The actual number of animals inspected was over a million and three-quarters. In this number there were nearly 300,000 Canadian animals shipped through the United States in transit to other countries, mainly Great Britain. The tuberculin test was applied to over 2,200 cattle and the mallein test to about 34,000 horses and mules.

Our exports of meat animals have decreased in recent years because of the heavy demand and high prices of the home market. The United States exports comparatively few live animals to Continental Europe, mainly because our stock is excluded by the policy of some of the European Governments.

#### OCEAN VESSELS.

Besides inspecting live stock for export, the bureau inspects the ocean vessels that carry such animals, and enforces regulations as to fittings, feed, water, attendants, etc., so as to insure that the animals will be carried in a safe and humane manner and reach the other side in good condition. In the five years mentioned 2,733 inspections of vessels were thus made.

On arrival at the principal British ports the animals are again inspected by the representatives of the Bureau of Animal Industry stationed there, as well as by the British authorities. Statistics show that the losses of live stock in ocean transit, which were formerly quite heavy, have been reduced to a negligible point under the bureau's supervision, and insurance rates have been correspondingly decreased.

#### STAMPING OUT DISEASES OF ANIMALS.

In suppressing and eradicating infectious diseases of live stock the Bureau of Animal Industry has been especially successful, and this work has saved the country from losses and damage that would otherwise have run into untold millions of dollars. To appreciate the effective work in our own country we must compare conditions here with those in other parts of the world where destructive animal diseases play havoc with the live stock. Even Europe, with its well-organized and efficient government forces, is overrun with foot-and-

mouth disease and other infectious diseases, and in spite of a continual struggle at great expense and with heavy losses the diseases persist. Fortunately in the United States we have kept out some of the worst diseases, and when foot-and-mouth disease and pleuropneumonia have gained entrance they have been stamped out by vigorous work before the infection had spread to such an extent as to place us in the unfortunate position of some of the European countries.

#### FOOT-AND-MOUTH DISEASE.

Since 1897 the bureau has twice been called upon to deal with outbreaks of foot-and-mouth disease of foreign origin, first in Massachusetts and adjoining States in 1902-3, and then in New York, Pennsylvania, Maryland, and Minnesota in 1908. Fortunately, the bureau was already equipped with a capable staff and organization, and each time the disease was promptly eradicated after a few months of vigorous effort, with the cooperation of State authorities.

The means used were strict quarantine, careful inspection, the slaughter of all diseased and exposed animals, and the disinfection of premises. Had it been necessary to lose time in getting together an organized force, and had the force been less capable, the infection would in all probability have extended to the great cattle-raising regions of the West, where it would have caused tremendous damage and where its eradication would have been much more difficult if not impossible.

The energy and promptness with which the second of these outbreaks was stamped out led an intelligent old farmer who had observed some of the work to express his commendation of the department's efficiency. He said that ours is a great Government, as shown by the fact that when a strange malady of an intensely infectious nature, capable of inflicting widespread and serious loss to live-stock owners, struck many herds over a wide area of territory, there appeared at once with the energy and promptness of a city fire department a Government force of veterinarians trained to cope with the disease, whose vigorous measures suppressed it completely almost before the people of the community had time to realize the gravity of the situation. And he remarked again that it was indeed a wonderful Government which was prepared to meet so unusual an emergency and to meet it in such manner.

#### TEXAS FEVER.

The department has also undertaken to rid the United States of certain diseases which have long existed here and which have been a heavy handicap to the stock-raising interests. All this work has been begun and carried on within the past 16 years, and the prog-

ress and results so far attained have more than justified the expense. The three diseases against which our administrative efforts have been chiefly directed are Texas fever of cattle, sheep scab, and cattle mange.

The boundary of the area infected with Texas fever was located by the department between the years 1882 and 1885, and since that time a quarantine has been maintained, and there have been restrictions on the movement of cattle from the quarantined area so as to prevent the spread of the disease. The discovery that the tick is the carrier and disseminator of Texas fever was made by scientists of the Bureau of Animal Industry in 1890, and the eradication of the tick has long been believed to be possible. No systematic effort, however, to eradicate these ticks was undertaken until 1906. In that year Congress made an appropriation for this purpose, and the work was begun in cooperation with authorities of the affected States.

When it was first proposed to undertake the extermination of the Texas-fever ticks this was regarded by many as an impossible task, but it was soon proven to be not only possible but practicable. Since the work was begun in 1906 about 165,000 square miles have been freed of the ticks and released from quarantine. This is equal to more than the combined areas of Georgia, Alabama, and Mississippi, and is nearly one-fourth of the total area infected at the time of beginning the work.

The objects of eradicating the ticks and thereby stamping out the disease are to give the cattle owners of the quarantined area an unrestricted market for their cattle, thereby enabling them to obtain better prices; to prevent the losses due to the tick as a transmitter of disease and also as a simple parasite; to increase the number and improve the quality of cattle in the South; to increase the fertility of the soil by promoting cattle raising, and to improve agricultural conditions generally. The losses due to the cattle tick are conservatively estimated at from \$60,000,000 to \$100,000,000 a year.

The eradication of cattle ticks is an important step in the agricultural regeneration of the South. The presence of this parasite has been a great handicap to cattle raising there, but with the tick out of the way the fine natural advantages of that section for cattle raising will enable the southern farmers to build up a profitable industry and add greatly to the country's beef supply, which is now running short. The eradication of the tick is also important for the development of the dairy industry.

#### SHEEP SCAB.

In 1899, owing to complaints from England that American sheep shipped to that country were frequently found to be infected with scabies, the department issued the first order relating to interstate

shipments of sheep affected with that disease. Federal inspectors were placed at the principal feeding points of all the railroads leading to market centers with instructions to inspect all shipments of sheep, and if any were found affected with scabies to supervise their dipping and treatment or allow them to proceed to a point where they could be dipped under Federal supervision. Later on this inspection of sheep was extended to the points at which the sheep originated and were accepted for interstate movement.

While this plan reduced the trouble and was more satisfactory to the sheep growers and transportation companies than the stock-yards inspection, still it did not eradicate the disease on the range to the extent that was hoped for. Accordingly, in 1904 a Federal quarantine was placed on all the territory west of the eastern border of North Dakota, South Dakota, Nebraska, Kansas, Oklahoma, and Texas, which included an area of 1,853,811 square miles. A plan of cooperation was arranged by the Department of Agriculture with the sheep sanitary commissions of several States providing for the inspection of all sheep and the proper treating of all flocks of sheep found to be affected with or exposed to disease. This plan was found to be very effectual and was taken up by other States as soon as State laws could be obtained under which the department could cooperate.

As a result of work under this plan a large area was in 1907 released from Federal quarantine on account of the nonexistence of disease, and from that time until the present there has been released an area comprising 1,171,590 square miles. This leaves only 682,221 square miles still in quarantine, and in this area sheep scabies exists to a very slight extent. As illustrative of this point it may be stated that when the eradication work was first taken up in New Mexico, in the spring of 1907, 48 per cent of the 4,500,000 sheep in that State were diseased. As a result of State and Federal cooperation and the annual dipping under Federal supervision of all sheep within the State, the inspection of sheep in the spring of 1912 showed the existence of less than 1 per cent of disease.

Contrary to predictions made by many woolgrowers, sheep scabies has within the last 10 years been practically eliminated from the United States, and as a result the sheep industry is in a very much more prosperous condition than when a heavy loss in the product of wool and mutton was each year experienced as the result of sheep scabies.

#### CATTLE MANGE.

In 1904 it became evident to the department that cattle scabies or mange existed quite extensively in the United States, especially in the territory west of the Missouri River and east of the Rocky Mountains. Accordingly, regulations tending toward the control and eradication of the disease were promulgated, and the areas where

cattle scabies was known to exist to the greatest extent were placed under Federal quarantine. This included an area covering about 452,632 square miles in several Western States.

As in the work of eradicating sheep scabies, Federal and State cooperation was resorted to, with the result that since 1907 cattle scabies has been successfully controlled and 218,572 square miles of territory released from quarantine.

While the area released from quarantine seems to show that the work is only half accomplished, this does not express the real progress made. As the extent to which disease exists in the territory still remaining in quarantine has been so greatly reduced, it will only be a short time until cattle scabies in the United States will be a matter of history.

#### BOVINE TUBERCULOSIS.

In 1907 the Bureau of Animal Industry first undertook to cooperate actively with individual herd owners and State and city officials in the eradication of bovine tuberculosis from dairy herds. In the first year 658 cattle were tested, of which 118, or 17.9 per cent, gave reactions indicating the presence of tuberculosis. These tests were applied only to cattle whose owners signed an agreement with the bureau providing for the slaughter or efficient quarantine of reactors, the tuberculin testing of animals added to the herd, the disinfection of infected premises, and the observation of proper sanitary measures. This work has grown in popularity until in 1912 cattle tested numbered 8,433, of which 769 were reactors or suspects. The percentage of tuberculosis now being found by annual retests in this territory has thus been reduced to 2.30 per cent. During the period covered 25,193 cattle have been tested.

In the fall of 1909 special cooperation in the eradication of bovine tuberculosis was given in the District of Columbia. In the first complete testing of the District cattle a total of 1,701 cattle were tested, of which 321, or 18.87 per cent, were tuberculous. A systematic retesting has reduced the percentage to 1.29, and in the meantime the testing of cattle entering from other States has prevented the introduction of diseased animals.

This cooperative work has been extended into various States which desired the assistance of the bureau in dealing with the bovine tuberculosis problem. The tuberculin test is also applied to cattle for breeding or dairy purposes for interstate shipment.

The effects of this work are well illustrated by the marked reduction in the prevalence of tuberculosis in the herds of cattle which are being maintained under bureau supervision. These results have been so satisfactory to the cattle owners that requests for cooperation far in excess of what can be done with the present force are con-

stantly being received from the individual owners, as well as from city and State officials.

#### SCIENTIFIC INVESTIGATIONS OF ANIMAL DISEASES.

Scientific knowledge of the causes and nature of animal diseases and their relation to human health is a necessary basis for administrative work in dealing effectively with such diseases. In the domain of scientific research the Bureau of Animal Industry has had a large share in the advancement of knowledge. The investigations of this kind have been carried on by the Pathological, Biochemic, and Zoological Divisions, and the Experiment Station.

#### THE CATTLE TICK.

Although some excellent results were obtained prior to 1897, the energies of the scientific staff were centered upon the study of only a few diseases. The country had but recently been freed from infectious pleuropneumonia of cattle, and as Texas fever was apparently the most serious animal disease existing at that time, much attention was devoted to the study of its cause and prevention. The later work relating to this disease has included the determination of the shortest and longest periods of time in the development, at all stages, in the life history of the Southern cattle tick, the carrier of Texas fever of cattle; the determination that apparently healthy southern cattle may continue to carry the parasite that causes Texas fever in their blood for years after they have been removed from the so-called infected territory and have been protected against all sources of infection, and the determination that noninfectious cattle ticks become infectious and capable of causing Texas fever by living a single generation on the bodies of southern cattle that have been kept half a dozen years or longer in apparently perfect health north of the Texas fever territory, and away from all sources of infection. These results form a series of contributions of the greatest importance in the practical work of the eradication of southern cattle ticks and the prevention of Texas fever.

The efficacy of arsenical dips as remedies for destroying cattle ticks and the proper strengths of the dipping solutions have been proved and determined by careful and prolonged investigations. Without an efficacious remedy like the arsenical dip, progress in tick eradication would be extremely difficult if not practically impossible.

#### BLACKLEG VACCINE.

The extensive losses of young cattle from blackleg, together with the perfection of a protective vaccine by Kitt and other European investigators, led to the inauguration in 1897 of the manufacture and

distribution of blackleg vaccine by the department. In the past 15 years more than 17,000,000 doses of this vaccine have been distributed to stock raisers. In regions where blackleg prevailed the losses formerly amounted to more than 10 per cent of the annual calf crop, but by the use of the vaccine the losses have been reduced to less than 0.5 per cent of vaccinated cattle.

#### TUBERCLE BACILLI.

The rapid increase of cases of tuberculosis among the animals slaughtered in the various packing houses of the country demanded the careful study of the many questions which were connected with this insidious disease. Consequently the presence of tubercle bacilli in the milk of cows that reacted to the tuberculin test but without showing any clinical indications of the disease was investigated by means of very extensive experiments.

The transmissibility and the transformability of the human, bovine, and avian types of tubercle bacilli was made the subject of study; also the different methods of immunization; the retention of vitality by tubercle bacilli that chance to be lodged in cheese, butter, or eggs; and the occurrence of the different types of tubercle bacilli in cases of natural infection of birds and animals in captivity.

Other investigations on tuberculosis have thrown much light on the relation between the location of tuberculous lesions in the animal body and the channels through which tubercle bacilli are expelled and disseminated from the bodies of tuberculous animals; on the persistence of the life and virulence of tubercle bacilli under different conditions and in different media; on the relation between tuberculosis of lower animals and human beings; on the relation between tuberculosis of cattle and tuberculosis among other species of animals; on the persistence of tubercle bacilli in a latent or semilattent state, without loss of virulence, in the tissues of living animals; on the causes that are responsible for the increased frequency of tuberculosis among hogs, etc.

The practical significance of some of this work is shown, for example, by the widespread interest taken in those studies on the elimination and dissemination of tubercle bacilli by tuberculous animals, which led to the discovery that tubercle bacilli are of common occurrence in the feces of even apparently healthy tuberculous cattle. This discovery at once offered an explanation for the occurrence of tubercle bacilli in the milk of tuberculous cows with healthy udders, and made it possible to prove definitely that the feces of tuberculous cattle are a common cause of tuberculosis among hogs.

#### HOG CHOLERA.

For many years the Bureau of Animal Industry carried on a systematic study concerning the cause of hog cholera. These investi-

gations culminated in 1903 in the discovery that this fatal disease is caused by a microorganism of such minute size that even the most powerful microscopes do not enable us to determine its form or structure. This discovery of the true cause of hog cholera enabled the department's investigators to attack the problem of prevention with intelligence and with some prospect of success.

Following the discovery of the true cause of hog cholera, the bureau succeeded in producing a protective serum from immune hogs which serves to prevent an attack of hog cholera in animals which would certainly succumb except for the serum inoculation. This antihog-cholera serum has been patented and assigned to the free use of the people of the United States. It has been found that this serum can be produced at a cost sufficiently low to warrant its employment in practice.

The department, through bulletins and other special notices, has advised all the States of the Union of this discovery and has urged them to undertake the manufacture of this serum for the benefit of farmers. At the present time 28 States have done more or less work along this line, and more than 1,000,000 hogs have been given the protective inoculation with most satisfactory results.

In order to understand what the discovery of this serum may mean to the people of this country, we need merely to consider that the value of property in swine in the United States exceeds \$500,000,000, and that a conservative estimate shows that the average yearly loss from hog cholera must amount to more than \$18,000,000.

The investigations of the department have thus placed the people of the country in a position to save all, or a greater part, of this loss and, furthermore, as the serum may be used to prevent hog cholera, farmers should soon be in a position to raise greatly increased numbers of hogs without being deterred, as they are now, by the fear of this destructive disease.

#### GLANDERS AND OTHER DISEASES.

The diagnosis of glanders, Malta fever, dourine, and infectious abortion by the application of complement-fixation tests to the blood serum is one of the recent achievements that has a far-reaching importance. By this method it is now possible to diagnose these diseases accurately and promptly. This is a great improvement over the uncertainty of former methods. About 2,500 complement-fixation tests were made during the past year.

Infectious abortion is a scourge of the cattle industry at the present day, and has been a subject of special investigation during the past two years. With prevention in view very extensive experiments have been made for the purpose of discovering some effective



and practicable method of immunizing exposed animals against this disease.

The demonstration of the occurrence of the bacillus of infectious abortion in market milk, of its continued elimination with milk by cows that have aborted, and that it causes well-marked, characteristic lesions in small experiment animals, may throw much light on the important question of infectious abortion among animals, and has added another argument to the many that have been discovered in recent years in favor of the general pasteurization of the public milk supply, as it is not yet known in what relation the abortion bacillus, which can affect many species of animals, may stand to human health.

#### INVESTIGATING LOSSES OF SHEEP.

Losses of sheep on the ranges of the West, through eating poisonous or narcotic plants such as the loco weed, and also from the diseases known as bighead and necrobacillosis, have been very heavy. The causes of these losses are being investigated by men of the Bureau of Animal Industry who have been detailed to the affected regions in order that they may study the outbreaks as they really occur.

#### DISEASES OF HORSES.

Another matter which receives attention in the midst of the affected area is swamp fever of horses, which occurs most seriously in the lowlands of the river bottoms in the northern prairie States. Forage poisoning of horses in the Middle West, as well as in several of the Atlantic States, has for several years proved to be a baffling and destructive disease and has received careful study, both in the field and in the laboratory. Dourine among horses has suddenly appeared on three or four occasions and has demanded prompt attention because of its contagious character.

#### RABIES OF DOGS AND OTHER ANIMALS.

The supply of dogs and other animals affected with rabies seems to be inexhaustible, and it is therefore necessary to make examinations of suspected material without any cessation. It is safe to say that many human lives have been saved through prompt and accurate diagnosis in the case of animals that had bitten people, the persons thus being informed when it was advisable for them to resort to the Pasteur treatment to prevent the development of hydrophobia.

Diseases of fowls and of pet stock are very important and are so frequently referred to the bureau that one or more men are kept constantly employed in dealing with them.

## SPECIFIC REMEDIES.

Bacterins, antitoxins, and numerous biological products for the prevention or treatment of various animal diseases are being placed upon the market in great profusion, and it has become necessary that some supervision should be placed over these preparations, as the chance for marketing fraudulent, worthless articles is so attractive to the unscrupulous that certain men are availing themselves of the offered opportunity for reaping a harvest. A beginning has been made in standardizing these products, and the value of all such products should be determined before they are placed on sale before the public.

For many years the bureau has furnished free of charge to official veterinarians, health officers, etc., tuberculin for the diagnosis of tuberculosis in cattle and mallein for the diagnosis of glanders in horses. In 1897 there were so furnished 7,000 doses of tuberculin and 1,400 of mallein. In 1912 the quantity of tuberculin amounted to 329,000 doses and mallein 135,000 doses. During the 16 years approximately 2,000,000 doses of tuberculin and 500,000 doses of mallein were supplied to State, county, and municipal officials. The tuberculin distributed has been used almost exclusively for testing dairy cattle for tuberculosis. The distribution by the department has enabled State officials to secure this reliable diagnostic agent promptly upon request, and they have employed it in various campaigns to remove tuberculous animals from dairy herds.

There are, of course, some dairy herds which are free of tuberculosis; there are others which are badly infected. The average percentage of tuberculous animals in dairy herds, as shown by these tests, extending over the past 16 years, is little if any below 5 per cent. It is certainly true that in most cases where tuberculous animals have been discovered by this test steps have been taken to remove the danger which they presented. It must therefore be assumed that this distribution of tuberculin has resulted in the removal from dairy herds of not far from 100,000 infected animals. The removal of these animals, of course, is of great importance to the public health and is also of economic importance on account of the menace to the health of the other animals in the herd.

Antigens for use in the various complement-fixation tests and precipitating sera for use in the diagnosis of glanders, Malta fever, anthrax, etc., have been prepared and furnished ready for use to laboratory workers in various States of the Union. In this class of materials may be included a bacterin preparation for the treatment of the buffaloes in the Yellowstone Park, which have been decimated by attacks of hemorrhagic septicemia.

A supply of stock cultures comprising many of the pathogenic organisms commonly producing disease in animals are kept constantly in cultivation and are at all times available for supplying scientists who desire to cultivate a collection of bacteria and for schools that need them for study and comparison.

#### ANIMAL PARASITES.

Some important work has been done with regard to animal parasites and parasitic diseases. The Zoological Division has worked out the life history of the stomach worm of sheep, a parasite which entails a loss of millions of dollars annually to the sheep industry of this country. This loss may be avoided or minimized only by the adoption of preventive and remedial measures based upon a knowledge of the life history of the parasite.

The presence of the gid parasite of sheep in the United States was discovered. The importance of eradicating this parasite has been pointed out, and a careful watch is kept for new centers of infection in order that more stringent measures may be taken in case the parasite should show a tendency to spread beyond its present restricted limits of distribution.

The common occurrence of a tapeworm cyst in the muscles of sheep has also been discovered. Investigations have shown that this cyst is the intermediate stage of a dog tapeworm, hence not dangerous to man. The presence of these cysts in mutton, however, renders it undesirable as food, and a considerable loss thus results to the meat supply of the country.

A common stomach worm of the horse has been found to be transmitted by the house fly. The infection passes from the manure of infested horses to fly larvæ breeding in the manure, and the full-grown flies developing from these larvæ in turn transfer the parasites to horses.

The discovery of the New World hookworm of man and its extensive distribution in the United States was made by a scientist of the Bureau of Animal Industry who has since gone to another branch of the public service. His far-reaching investigations were begun before he left this department.

Numerous new species of parasites of varying degrees of economic importance have been discovered in the course of the bureau's work in parasitology, and a complete index to the extensive literature concerning parasites has been compiled and published.

#### BENEFICIAL RESULTS WIDELY DIFFUSED.

It can readily be seen that the activities and benefits of these scientific investigations extend into every section of the country, and that the work performed does much to check and to overcome the ad-

vance of every contagious epizootic as well as to cure the animal that is suffering from a less dangerous ailment. The lives of countless animals are preserved each year, and because of the investigations of materials which form an important part of the daily food of the people of the country, human lives are also helped and lengthened and in many instances sickness and death are prevented.

#### EXPERIMENTAL FARMS.

Some of the investigations require farm conditions. In 1897 the Bureau of Animal Industry had for this purpose an establishment for which the name "experiment station" was a misnomer. It was located on a rented tract of land with an area of less than 6 acres. The available buildings for housing animals and laboratory purposes were a few one-story frame structures which could be duplicated, together with their entire equipment, for about \$3,000, and the duplication of which at any price, for any purpose, would be extravagant.

The experiment station is now located on a 50-acre tract of land owned by the Department of Agriculture, at Bethesda, Md. Its laboratory is a \$25,000 fire-proof building, and the entire property, including buildings, roads, water, and sewage systems, etc., is worth at least \$75,000. This station is used for investigations concerning diseases of animals, and is well equipped for the purpose.

The bureau also has a farm at Beltsville, Md., for investigations in animal husbandry and dairying. This farm, which was bought by the department in 1910, consists of 475 acres of land, and is being equipped for the work for which it is intended. This farm affords facilities that have long been needed, and is expected to yield valuable results to the stock-raising and dairy interests of the country.

#### BIOLOGICAL SURVEY.

##### EARLIER DUTIES.

During the past 16 years the work of the Biological Survey has been greatly enlarged and its field broadened, as is shown by a comparison of appropriations and number of employees. The appropriation for the fiscal year 1897 was \$20,560, while that for 1913 was \$191,400; the number of employees increased from 23 in 1897 to 97 on July 1, 1912. In 1897 the office, then known as the Division of Biological Survey, was charged with two main lines of work—investigation of the geographic distribution of mammals and birds and studies of the food habits of the useful and injurious species.

##### IMPORTATIONS OF LIVE BIRDS AND WILD ANIMALS.

In 1900 under the act regulating importation and interstate commerce in birds and game the survey was given supervision of all

importations of live birds and wild animals. Under a system modeled after that of western Australia, and in cooperation with the Customs Service of the Treasury Department, a system of permits was carried into effect which has made it possible to trace each consignment imported from abroad, and to exclude any injurious species.

For the fiscal year ending June 30, 1912, the total number of mammals imported from abroad was 5,457, and the total number of birds 457,077. In other words, we are now importing foreign birds (chiefly cage birds) at an average rate of more than 1,000 a day, and a systematic record is kept of all such importations at each of the entry ports of the United States and in Hawaii.

No other country has undertaken so comprehensive a system to prevent the introduction of species which may become injurious to agriculture. Congress, recognizing the increased field of operations of the office, raised the division to the rank of a bureau on July 1, 1905.

#### DISTRIBUTION AND HABITS OF NATIVE MAMMALS AND BIRDS.

The basis of most of the work is scientific investigation, and in this field the most notable accomplishments have been the systematic collection and publication of data regarding the distribution and habits of native mammals and birds, and the preparation of maps showing the natural life zones of the country. Each of these zones is especially adapted to the growth of special crops and marks the limits within which certain varieties of fruits and cereals produce the greatest yield or beyond which they are not likely to be commercially successful.

Maps showing the ranges of individual species have also been published, and have proved useful in cooperative work with the Public Health Service in outlining the range of mammals which carry the tick responsible for the deadly spotted fever in the Bitter Root Valley, Mont., and the area occupied by the ground squirrels in California which transmit bubonic plague.

Maps have also been prepared showing the distribution of other species of ground squirrels, of pocket gophers, prairie dogs, wolves, and coyotes, all of which are extremely destructive to stock and agricultural interests in the West. The survey has mapped the ranges, determined the abundance, and studied the habits of many of the North American mammals and birds, and the knowledge thus gained makes it possible to cope with most of the economic problems in which native species are involved. Detailed studies have been made of certain regions of special interest, notably of Mount Shasta, Cal., and of the States of Colorado and Arkansas. A report has been published on the birds of Arkansas, forming the first complete list

of the birds of that State ever issued. Comprehensive lists of the birds of Alabama and Texas are now in course of preparation. The latter, on account of the richness of the Texas fauna, will include more than one-half of the species known from North America north of Mexico.

#### FOOD HABITS OF BIRDS.

Careful studies have been made of the food habits of birds considered injurious and of many species that are known to be beneficial. More than 50 species of birds have been found to destroy the cotton boll weevil and 31 have been found to feed on the alfalfa weevil which has recently become so destructive in Utah. Special studies have been made of the food of birds in the fruit-growing districts in California and of special generally distributed groups, such as the flycatchers, grosbeaks, shore birds, and waterfowl. A summary of some of these studies, entitled "Common Birds in Relation to Agriculture," has proved one of the most popular bulletins ever issued by the department, more than half a million copies having been distributed in recent years.

#### SPECIES INJURIOUS TO AGRICULTURE.

Much attention has been devoted to species injurious to agriculture, and methods have been devised for destroying English sparrows, wolves, coyotes, moles, rats, ground squirrels, and prairie dogs. When it is considered that 32 prairie dogs will eat as much forage as one sheep and 250 prairie dogs as much as one cow, it can readily be seen how important is the destruction of these animals on grazing lands in the West. Even the crawfish, which are destructive in cotton fields in certain sections in Mississippi, have received attention, and methods of destroying them with bisulphide of carbon have been devised. This work has by no means been confined to experiments on a small scale. In cooperation with the Forest Service, the prairie dogs on considerable areas in the National Forests of Colorado have been poisoned, and the mice, chipmunks, and other rodents have been destroyed on seed plots and extensive tracts where the work of reforestation has been undertaken on the forests in the West.

#### GAME PROTECTION.

In connection with the work of game protection the Biological Survey is called upon to issue permits and inspect shipments of wild animals and birds imported alive from foreign countries; to enforce the laws relating to interstate commerce in game; to enforce the law relating to protection of birds on national bird reservations; to ad-

minister 56 bird reservations and one or two big game reservations; and to cooperate with the several States in the protection of game.

These duties, authorized by act of Congress of May 25, 1900, have considerably broadened the field of work and have brought the survey into close touch with several of the other executive departments and with most of the State fish and game commissions. Supervision of the importation of foreign birds is carried on in cooperation with the Treasury Department, and in the maintenance of the bird reservations cooperation of at least six other departments—Interior, Treasury, Justice, War, Navy, and Commerce and Labor—is occasionally necessary.

Through cooperation with game commissions and associations of the various States and through its publications the department has been able to advance the cause of game protection materially, and in some instances to mold public opinion on certain matters of general interest. The last decade has witnessed a wonderful advance in game protection in the United States, and in this movement the Biological Survey has taken a prominent part. Native species have been almost entirely eliminated from the cage-bird traffic and have been largely eliminated from the plumage sold in this country for millinery purposes. Restrictions on export and sale have greatly reduced the enormous shipments of game to market which were so common a few years ago. A system of hunting licenses has been adopted in most of the States, and the number of States which have provided game commissions intrusted with enforcement of game laws has increased from 31 in 1900 to 43 in 1912.

#### DIVERSIFIED DUTIES.

Under its present organization, the Biological Survey is charged with such diversified duties as investigations relating to destruction, migration, and economic relations of birds and mammals; prevention of the introduction of species injurious to agriculture; maintenance of about 60 reservations; solution of problems involving the permanent preservation of buffalo, elk, antelope, and other big game and of numerous species of birds. Recently a movement has been started to intrust the department with the supervision of the protection of migratory birds, and bills providing for this new work have been introduced in Congress and have been favorably reported by the respective committees in the House and Senate.

#### WEATHER BUREAU.

##### ENORMOUS DEVELOPMENT.

Owing to the nature of its duties, the Weather Bureau is probably the most widely known bureau of the Department of Agriculture, and as the weather enters into practically every phase of human

activity the extent to which the information it collects and distributes can be used to advantage and profit is scarcely to be limited. In attempting to speak, therefore, of the extension of its benefits during the past 16 years, it is not possible to do more than to touch on the more striking features of its work.

The benefits to be derived from its forecasts, warnings, and miscellaneous reports depend largely upon the extent to which the general public has been educated in the use of the information furnished. That there has been an increase of appreciation on the part of the people of this country in this respect was fully brought out several years ago when the Weather Bureau made inquiry regarding the uses to which weather information was applied. The replies received showed numerous special applications of the information to individual pursuits and industries that had not even been suspected by the Weather Bureau.

Since 1870 the Federal Government has maintained a service having for its objects the forecasting of weather conditions throughout the United States. During the first 20 years of its development the work was conducted by the Signal Corps of the Army, but in 1891 the service was reorganized and the present Weather Bureau was established as a branch of the Department of Agriculture.

With the inauguration of the meteorological service in 1870, under the control of the War Department, there were established 25 regular observation stations. In 1896-97 this number had been increased to 131. At the present time the Weather Bureau has 193 regular stations of the first order, which take and telegraph observations twice daily.

A further general idea of the development of the service may be obtained from a comparison of the annual appropriations for its maintenance. In 1870 the Secretary of War set aside the sum of \$20,000 for the first year's work in maintaining the 25 stations then established. In 1896-97 the annual appropriation for the Weather Bureau was \$883,772, while the sum appropriated by Congress for the maintenance and operation of the Weather Bureau in all its ramifications during the fiscal year ending June 30, 1913, was \$1,619,680.

#### EXTENSIONS OF OBSERVATIONS AND FORECASTS.

Prior to 1897 the forecaster had under observation twice each day the atmospheric conditions over the area comprising the United States and extreme southern Canada. At the outbreak of the Spanish-American War in 1898 the field of observations was extended to include the West Indies, where the majority of the violent tropical storms that devastate the southern coasts of the United States



make their appearance. In the same year reports were received for the first time from Mexico, and in later years the establishment of a number of stations in the Rocky Mountain and plateau regions afforded much needed information to the forecaster. In 1900 the daily survey of atmospheric conditions was extended to the British isles, continental Europe, Bermuda, and the Azores, through the cooperation of the meteorological services of those countries, and in 1907 the field was further extended to include Iceland, Asia, and Alaska.

At the present time there is prepared each morning in the forecast room of the central office of the Weather Bureau a chart showing the atmospheric conditions in middle latitudes around the northern hemisphere. No other meteorological service prepares a world-wide weather map. This chart not only affords material aid in the preparation of the daily forecasts but has made possible the making of forecasts for a week in advance.

#### WEEKLY FORECASTS.

The weekly forecasts are given wide publicity through the press, and their accuracy has been the subject of much favorable comment. This extension of the forecast period marks the greatest advance of weather forecasting in recent years. That the enlarged survey is also an important aid in the preparation of the daily forecasts is attested by the following table, which shows the increase in the percentage of accuracy for the year ending June 30, 1912, over the year 1893:

1911						1912					
July.	August.	September.	October.	November.	December.	January.	February.	March.	April.	May.	June.
7.2	12.8	1.7	1.6	4.0	6.4	6.1	4.2	3.9	5.2	3.5	5.8

The annual percentage of verification for the 12 months ending June 30, 1912, was 88.5, or 7 per cent higher than in 1893.

#### USE OF THE RADIOTELEGRAPH.

During the hurricane seasons of 1910 and 1911 reports of wind, barometer, and weather conditions were received by radiotelegraph from vessels in the Gulf of Mexico and the Caribbean Sea and off the south Atlantic coast, and on two occasions these reports gave the first indications of the formation of hurricanes in those regions. This was the first successful effort to employ the radiotelegraph in weather forecasting.

The service is at present in successful operation on 50 vessels plying the Atlantic Ocean from New York to West Indian and southern ports, and the Gulf and Atlantic between New Orleans and the West Indies, and it is now reasonably certain that no hurricanes will reach our southern coasts unannounced.

A similar service has been partly inaugurated on the Pacific Ocean, where cooperating vessels make daily weather reports to the Weather Bureau officials at San Francisco and Portland, while stations in Alaska and the Aleutian Islands make daily reports of weather conditions by wireless.

There is also under consideration the extension of the field of observations to the north Atlantic steamship routes by means of radiotelegraphy, which will make possible the issue of warnings concerning weather, winds, and storms over that region for the benefit of shipping.

A still more ambitious project, growing out of the deliberations of the International Radiotelegraphic Conference, held in London, England, last June and July, has in view the taking of meteorological observations by all trans-Atlantic steamers, those taken east of the fortieth meridian to be forwarded direct to some point in Europe (London or Paris), and those taken west of that line to be sent to Washington. It has also been recommended that five vessels be equipped for the exclusive purpose of taking observations in the West Indian waters during the hurricane season from June to November, at which time the certainty of receiving daily reports will be particularly valuable in insuring the safety of vessels at sea.

#### STORMS OF TROPICAL ORIGIN.

Of the severe storms of tropical origin that visited the eastern and southern coasts of the United States during the last 16 years, warnings were in all cases issued in advance of their arrival. Probably the most destructive was the Galveston hurricane of September, 1900, when 6,000 lives were lost, and damage to the extent of \$30,000,000 inflicted. In 1909 and 1910 severe hurricanes visited the Florida Peninsula, but owing to the accurate and timely warnings of the Weather Bureau comparatively little damage resulted. Hundreds of employees of the Florida East Coast Railway at work in exposed locations along the keys at that time, as well as barges and other movable property, were removed to places of safety as a result of warnings given by the Weather Bureau.

#### COLD-WAVE WARNINGS.

The warnings of those sudden and destructive temperature changes known as cold waves are probably next in importance to the storm and hurricane warnings. These warnings are issued from 24 to 36

hours in advance of the cold wave, and are often of immense value. During the severe cold wave of January 1-5, 1896, which overspread nearly the entire United States east of the Rocky Mountains, the warnings were issued 36 hours in advance and resulted in saving over \$3,500,000 through the protection of property from injury or destruction.

Among the successful weekly forecasts that have been issued in recent years those of July and December, 1911, were particularly prominent. That of July successfully announced the breaking up of a hot wave that had prevailed for some time over the Eastern and Middle Western States. Again, on December 24, the weekly forecast stated that, following a prolonged period of high temperature, severe winter weather would visit the United States by the beginning of 1912. The coldest weather in years occurred in the southern plateau region, freezing temperatures were recorded in California, a cold wave of marked intensity prevailed over the Plains States and Mississippi Valley, and the change to colder was felt to the Gulf and Atlantic coasts.

#### DISTRIBUTION OF FORECASTS AND STORM WARNINGS.

The distribution of forecasts and of cold-wave, frost, and storm warnings, for the benefit of agriculture and commerce, and in a special way for the protection of fruit, cranberry, tobacco, sugarcane, and other crops, has been greatly extended during the past 16 years. The following table compares the distribution to places or addresses in 1896 with that given in 1912:

Issue of forecasts and warnings.	1896	1912
<b>At Government expense:</b>		
Forecasts (daily).....	1,581	2,059
Special warnings only.....	598	946
Emergency warnings.....	3,481	5,154
<b>Without expense to Government:</b>		
Mall (forecast card).....	22,642	89,512
Rural delivery.....		30,539
Telegraph and telephone.....	1,712	5,462,212
Railroad telegraph.....	3,550	451
Railroad train service.....	1,939	2,343
Total.....	35,503	5,593,216

As will be observed, the main extension has been accomplished by means of rural free delivery and telephone service. The Rural Free Delivery Service was inaugurated in 1900 through the hearty cooperation of the Post Office Department. Owing to the prosperous condition of the farming interests, the telephone is rapidly supplanting the rural card distribution. Through the cooperation of the telephone companies, the telephone has become, next to the daily newspapers, the most extensive and expeditious means of disseminating the daily weather information; by this means more than 5,000,000 telephone subscribers get the forecasts daily. Moving-

picture screens are also being utilized in eight large cities for displaying the weather forecasts for the information of the general public.

The forecast distribution already described does not include that effected through the issue of the daily weather maps. In 1896 these maps were issued at 75 stations, having an annual output of more than 3,000,000 maps. At present the map is printed at 58 stations, having an annual issue of over 6,000,000 maps. The decrease in the number of stations issuing the regular station weather map has been brought about through the substitution at many points of a newspaper map, generally known as the commercial map. A map of this character was first printed at the Centennial Exposition in 1876, and in 1896 it was being published in four papers, having a combined circulation of 110,000 daily. In 1910 a plan for its issue under improved methods was brought to the attention of the press of the country, and the officials of the bureau were urged to make every effort to obtain a wide circulation of the publication by this means. At the end of four months 65 papers were publishing the map, and by the following January 100 dailies were making this an important news item. In July, 1912, the commercial map was being prepared at 91 stations and furnished to 147 daily newspapers, with an annual circulation of 985,000,000 copies.

At the beginning of 1896 there were 173 storm-warning display stations in operation. The number has gradually been increased, until in 1912 there are 619 stations displaying signals to warn mariners of approaching storms. Twenty-five of the stations also disseminate storm warnings by radiotelegraph to vessels at sea.

#### FROST STUDIES AND WARNINGS.

Since 1896, 89 special stations have been established in the fruit sections in connection with the study of frost formation and to assist in making more accurate forecasts and frost warnings for mountain orchard districts, cranberry marshes, the northern vineyards, and deciduous fruit sections. Prior to that time frost warnings were based on reports of general conditions only, no data from the fruit districts being available from which the influence of local conditions of topography and air drainage could be taken into account. The extension of this special warning service into new districts is shown in the following table:

*Districts receiving special frost warnings.*

In 1896.	In 1912.		
Florida. Louisiana. Texas. California.	North Carolina. Florida. Louisiana. Texas. Colorado.	Utah. California. Oregon. Washington. Idaho.	Wisconsin. Ohio. New Jersey. Massachusetts.

Investigations are now being carried on in the mountain orchard districts of North Carolina with a view of determining the limits of the thermal belts in the Blue Ridge Mountains. Ten orchard stations with 29 substations have been established, and it is proposed to extend the service by the establishment of 10 additional stations on other spurs of the mountains.

Under the Portland (Oreg.) district frost investigations are carried on in the Rogue River Valley, Umpqua Valley, Stuck River Valley, Yakima Valley, Snake River Valley, Boise Valley, and Hood River Valley. The official at Portland hopes to extend this service by the establishment of 4 stations in the Boise section, 2 in Hood River, 2 in Riddles, and 5 in North Yakima. In the Lewiston (Idaho) district 3 stations are in operation. The San Francisco district has 5 stations around Los Angeles and in the northern and central counties, where the annual value of the citrus-fruit interests is placed at \$40,000,000. During the past year it is estimated that by the timely warnings of the bureau at least \$20,000,000 worth of fruit was saved. An extension of this service by the establishment of 12 fruit district stations in the San Gabriel Valley, 2 in the Santa Clara Valley, 3 in the San Joaquin Valley, and 5 in the Sacramento and Bay Valleys has been recommended.

In the Salt Lake district experiments for the protection of fruit by means of canopies have been carried on at Provo, and stations have been established at four other places in connection with investigations looking to the protection of vegetables and alfalfa from frost. Under the Grand Junction district is the service in the Grand River and Gunnison Valleys with five stations. Four stations have been established in the Columbus (Ohio) district, and experimental work has been started for the protection of vineyards. In the Jacksonville district the frost-warning service for the protection of truckers and citrus-fruit growers has been established with four stations in operation.

The special cranberry service gives warnings of frost in the bogs of the Cape Cod (Mass.) district, where five special stations have been established under the supervision of the official at Boston; and the bogs in Wisconsin, with three stations under the supervision of the official at Chicago. A station has also been established at New Lisbon, N. J., and another at Seaview, Wash.

#### RIVER AND FLOOD SERVICE.

On July 1, 1897, there were 150 river stations operating under the river and flood service of the Weather Bureau. The success of the river forecasts during the great flood of 1897 created a demand for the extension of the service that has never been fully satisfied, but

increases have been made gradually until at present there are about 425 river and 25 rainfall stations distributed along all except the very smallest rivers of the United States.

The river forecasts issued daily by the Weather Bureau have contributed in no small measure to the success of navigation in the great inland waterways of the country. Flood warnings are issued whenever necessary, giving specific information as to the time of arrival of floods, the highest stages expected, and the duration of the floods. This information is of the greatest value to agriculture and many other interests.

Previous to 1897 the forecasts rarely attempted to indicate the exact heights that the floods would attain, but study and investigation have resulted in constant improvement until exact flood forecasts can now be made for periods from one day to four weeks in advance. For several years the river and flood service has been engaged in the preparation of forecast schemes for all the principal river systems—in other words, in developing rules applicable to forecasting in each of the rivers, and making a permanent record of these rules for future use. Schemes of this character have already been completed for the Ohio River and its tributaries, and the study of the Mississippi River is now under way.

During the Mississippi flood of 1897 property to the value of about \$15,000,000 was saved through the Weather Bureau flood warnings, and as much during the flood of 1903, while during the great flood of 1912 a saving exceeding \$16,000,000 was reported. During a single flood in the Sacramento Valley of California in 1909 property to the value of \$300,000 was saved through the warnings of the Weather Bureau, and similar instances are matters of frequent record. The work has kept pace with the development of the country, and its usefulness is limited only by the amount of money that Congress is willing to provide for its maintenance.

#### MARINE METEOROLOGICAL CHARTS.

Upon the recommendation of the Board on Wireless Telegraphy in July, 1904, and approved by the President, the ocean meteorological work and the collection of observations from vessels at sea, formerly under the Hydrographic Office, Navy Department, was transferred to the Weather Bureau. At that time 570 vessels of all nationalities were taking observations and rendering monthly reports. The number cooperating with the Weather Bureau on July 1, 1912, was 2,291.

The observations thus collected are used in the preparation of marine meteorological charts of the oceans and the Great Lakes. These charts are given free issue to vessel captains, marine interests,

libraries, and other individuals or institutions interested in the marine meteorological work of the Weather Bureau.

The charts of the north Atlantic were first published in 1909, with a monthly issue of 3,000, which has since been increased to 6,000. The north Pacific issue in 1909 was 1,500, while the issue at present is 3,100; that of the south Atlantic has been increased from 1,000 to 2,230, the south Pacific issue from 1,500 to 2,250, the Indian Ocean edition from 1,800 to 2,250, and that of the Great Lakes from 1,000 to 1,200.

#### VESSEL-REPORTING SERVICE.

The Weather Bureau maintains vessel-reporting stations at Block Island, Cape Henry, Sand Key, Southeast Farallon Island, Point Reyes Light, North Head, Port Crescent, and Tatoosh Island, where, in addition to their meteorological duties, the officials are required to report all wrecks, marine disasters, etc., and to transmit communications between owners, underwriters, and others interested in marine matters. As an instance of the enormous volume of work of this character done at these stations, it may be mentioned that during the year 1912 the Weather Bureau station at Cape Henry, Va., reported 19,876 vessels as having passed that station.

#### COOPERATIVE OBSERVATIONS AND CLIMATOLOGICAL REPORTS.

It was early apparent that only a limited number of telegraphic observation stations were required for forecasting purposes. For establishing and recording the climatic conditions of the country, however, it was necessary that a much wider distribution of observation stations be provided. This gave rise to the establishment of the climatological service of the bureau, which was brought about by enlisting the cooperation of public-spirited citizens in the formation of a widespread system of observations. At first a full equipment of the few scattered stations with standard instruments was not possible, and the results obtained from many of the early observations were unsatisfactory. During the last 10 or 15 years, however, the equipment has been improved until now practically all stations are supplied with accurate and well-exposed instruments.

In the earlier years this system covered only the older settled districts, but the observation stations were gradually extended into the far western mountains and valleys, and even into the island dependencies and Alaska. At the present time no important area of the country is without the means of approximating its main climatic features.

During the past 16 years the number of cooperative stations has increased from less than 3,000 to slightly more than 4,000, practically the entire extension having been effected in the trans-Mississippi districts.

## PUBLICATIONS.

With the great industrial developments of recent years has come a better knowledge of the dependence of most enterprises upon weather changes and climatological conditions. To meet the demands for information arising from a recognition of this fact it has become necessary to issue many climatological publications. Prior to about 1896 these were decidedly meager in contents, but since that time the introduction of printing facilities at a number of the more important stations has enabled the preparation of elaborate reports, which have rapidly increased in circulation with each succeeding year.

The most important of these is the Monthly Weather Review, containing statistics of weather conditions for more than 4,000 different points in the United States; the monthly edition of separates of the review now exceeds 14,000 copies.

The annual reports of the chief of bureau contain condensed summarized data for the year from all observation stations, together with charts and tables of many of the important elements.

The National Weather Bulletin summarizes the weather conditions for each week during the crop-growing season and for each month during the remainder of the year.

The snow and ice bulletins issued during the winter months indicate the protection afforded the cereals and grasses by the snow cover and furnish data regarding ice in the principal rivers and harbors of the country.

Monthly reports on the snowfall in the mountain States are issued during the winter for the benefit of irrigation and water-power interests, and daily bulletins of the weather over the great cereal and cotton-growing States during the period of growth and harvest are given wide distribution.

Lastly may be mentioned the summaries of climatological data for 106 district sections of the United States, having the data arranged in convenient form for the use of hydraulic engineers, water users, and agriculturists. Nearly 300,000 copies of these summaries have been printed in response to the numerous demands.

The total number of climatological publications and reports issued yearly now exceeds 1,000,000 copies.

## INSTRUMENTAL EQUIPMENT AND APPARATUS.

At the present time more than 200 stations, maintained for regular telegraphic reports, are equipped with the instruments essential to complete meteorological observations, while a number of special stations established to carry out particular lines of research have also been supplied with the instruments essential to their work. The structural details of most of the instruments have been modified and



improved from time to time, although the general type and design have remained the same.

Besides the improvement in the instrumental equipment at the regular Weather Bureau stations a good type of thermometer shelter is fast being furnished to the cooperative climatological stations, which now number 4,000, and of which 3,100 are equipped with the standard shelter, in addition to the thermometers and rain gauges used at those points.

Beginning in 1900 the equipment of storm-warning display stations has been steadily improved by the installation of steel towers and the use of high-power oil and electric lights for display of flags and night signals. More than 200 of these towers are in use at the present time.

With the beginning of aerial studies in the winter of 1895, a standard type of construction of the Hargrave box kite was perfected and has been employed without appreciable modification in the subsequent work of the bureau, as well as at a number of European observatories. The same is true in regard to a light form of meteorograph that is sent up with the kites for recording the pressure, temperature, humidity, and wind velocity. In the course of the aerial work several excellent forms of windlass were designed for winding and unwinding the steel piano wire used in the kite ascensions.

Earthquake vibrations have been recorded in a more or less complete manner at the Washington office of the Weather Bureau for many years. In 1903 a modern type of seismograph of superior design was installed. The equipment was subsequently improved by the installation of a more sensitive new type of seismograph designed and constructed in the Instrument Division, and records have been obtained of all the important earthquakes that have since occurred.

Several useful improvements in methods and devices for observing and measuring evaporation were also developed and used in connection with the special evaporation studies conducted by the Weather Bureau in 1907-1909.

Observations of the intensity of solar radiation began with the use of the Ångström pyrheliometer. An improved type of disk pyrheliometer has been developed in the Instrument Division, and this form of instrument is now being used at Mount Weather, Va.; Madison, Wis.; Lincoln, Nebr.; and Santa Fe, N. Mex.

The accuracy of anemometer records at very high wind velocities has never been completely established. This work has recently been undertaken with the aid of a large whirling machine set up at Mount Weather, Va. Through its use a test will be made of all the important types of anemometers at velocities up to and beyond 100 miles per hour.

A special structure of ornamental character was devised in 1908 for the purpose of displaying meteorological instruments and weather

charts in the parks or on the streets of large cities. These kiosks, as they are called, have been installed in 37 of the larger cities of the country and have proved an excellent means of acquainting the average citizen with the way in which the Weather Bureau obtains and distributes its weather information.

#### EVAPORATION STUDIES.

The formation of the Salton Sea in the desert of southern California by overflow flood waters from the Colorado River afforded an exceptionally favorable opportunity for the study of the general problem of evaporation. A preliminary campaign was begun at Reno, Nev., in 1907, and an elaborate investigation followed during 1908 and 1909 at the Salton Sea, with the primary object of determining an evaporation formula that would be of general application. The results obtained were somewhat negative, indicating that, owing to differing meteorological conditions, the law of evaporation must be established independently for each separate locality. A great mass of valuable data was secured, however, and the work can not by any means be considered a failure.

#### FOREST AND-RAINFALL INVESTIGATIONS.

The problem of the conservation of the natural resources of the country has in recent years become one of the great issues of the day. As might naturally have been expected, honest differences of opinion have arisen in connection with various phases of the question. Probably none has been the subject of more vigorous discussion than that relating to the effect of forestation or deforestation upon water supply and water control, particularly with reference to floods. As the data at hand were apparently not conclusive, the Weather Bureau and the Bureau of Forestry of the Department of Agriculture combined forces in 1910 for a thorough investigation and study of the entire problem, in the hope of arriving at results that would be accepted as authoritative; and two small and similar watersheds in the Rio Grande National Forest in southwestern Colorado were selected as offering suitable conditions for prosecuting the necessary investigations. An elaborate equipment was provided, and observations are now being taken daily over both watersheds. In 8 or 10 years it is proposed to deforest one of the watersheds and then to continue the observations over both for another period of 8 or 10 years. At the end of the second period the results are to be promulgated with such conclusions as are warranted by the facts. Foreign countries have expressed great interest in the experiment, and the final results and conclusions will doubtless prove of much value.

## MOUNTAIN SNOWFALL WORK.

For many years hydraulic engineers engaged in the mountainous regions of the West were confronted with discrepancies between precipitation and run-off that were unexplainable at the time. In many localities the total annual run-off would be greater than the total measured precipitation. It was evident, of course, that the measurement of the precipitation was deficient in some way, and it was finally agreed that the trouble was due to the want of snowfall measurements in the high mountains.

Consequently, about three years ago a mountain-snowfall campaign was inaugurated by the Weather Bureau. Special apparatus was devised, and about 275 mountain-snowfall stations were opened. Snowfall measurements were made daily or weekly, according to the locality, and the depth and water equivalent of the snow carefully computed. Later it was found that some portions of the equipment were not entirely suited to the conditions, and improved apparatus has been devised in the form of a shielded rain and snow gauge. As a result of the observations thus secured the difficulties of the hydraulic engineer have already been lessened. The data are now comparable, and computations of future water supply from the winter snows in the mountains can be made with a considerable degree of accuracy.

Provision has also been made for measuring the water equivalent of snow that must be depended upon to supply water for irrigation purposes in a portion of the subarid West. A special snow survey in Utah has demonstrated the possibility of making a reasonably accurate forecast of the amount of water that will be available each season for the uses of the irrigation farmer. If the supply promises to be greater than usual, water-supply companies can arrange to dispose of more water and farmers can cultivate more land. On the other hand, if the supply promises to be less than usual, the water distribution can be lessened and the area under cultivation be restricted. The great utility of such advance knowledge is readily apparent.

## BAROMETRY, THERMOMETRY, AND CLOUD OBSERVATIONS.

In Volume II of the Annual Report of the Chief of the Weather Bureau, 1900-1901, is published the "Barometry of the United States and Canada." All the barometer data were reduced to a homogeneous system of station normals computed for the epoch January 1, 1900, requiring in the case of many stations a computation of the record for 27 years. From these computations barometer tables for the reduction of the pressure readings to sea level were computed.

Such a system of normals develops many interesting and important cosmical problems, especially those regarding the seasonal variation of the climate and the forecasting of the weather conditions for longer intervals than at present practicable.

In 1907 the daily temperature normals, computed for a period of 33 years, 1873 to 1905, inclusive, were published.

In 1894, in accordance with the recommendation at the International Conference at Munich of 1891, resolutions were passed by the committee on cloud observations, inviting all countries to cooperate in cloud observation work beginning May 1, 1896. The Weather Bureau conducted these observations at 15 stations throughout the United States, and from these observations deductions were made as to the height of all classes of clouds. The "Report on the International Cloud Observations," May 1, 1896, to July 1, 1897, was published as Volume II of the Report of the Chief of the Weather Bureau, 1898-99.

#### MOUNT WEATHER (VA.) RESEARCH OBSERVATORY.

The plan to found an observatory at Mount Weather, Va., for research work took definite form in 1903, in which year a site was obtained on the summit of the Blue Ridge, 6 miles south of Blue-mont, Va. The main building was erected in 1904, but in October, 1907, it was destroyed by fire. In 1909 a fireproof structure was erected on the foundation of the old building, a central heating and power plant was also constructed, and several buildings which had been begun at an earlier date were completed.

While the buildings were being constructed scientific work was carried on under difficulties. Surface meteorological observations were begun in November, 1904, and the results have been telegraphed to Washington daily since that time. The years 1905, 1906, and part of 1907 were spent in installing and testing instrumental equipment and in experimental work preparatory to the exploration of the free air, which at that time seemed to be a promising subject of investigation.

#### EXPLORATION OF THE UPPER AIR WITH KITES.

While some experimental kite flights were made as early as the autumn of 1905 the regular program of daily flights on week days did not begin until the summer of 1907, and it was not until July, 1909, that flights on Sundays were included in the regular program. The effort to get a daily sounding in all sorts of weather conditions has been a sustained and fairly successful one. In the four years, 1909-1912, there were but 39 days on which it was not possible to make a kite flight or captive-balloon ascension. When weather conditions were not favorable many of the flights naturally extended

but a short distance into the air, thus making it impossible to follow the changes from one day to the next when the flights were of unequal altitude. In the five years' campaign, however, the observatory has succeeded in locating the dangerous sectors of a storm and in roughly determining from surface conditions when it is unsafe to navigate the air. The service thus rendered to the science of aviation will be more fully appreciated as time passes.

It may properly be said that the kite force at the Mount Weather Observatory brought the art of kite flying for meteorological purposes to the highest state of proficiency ever attained in this or any other country. On May 5, 1910, 10 kites, with 11.5 miles of wire, carried a recording instrument to an altitude of 4.5 miles above sea level, the greatest altitude ever reached by a kite. From July 1, 1907, to June 30, 1912, 1,772 kite flights or captive-balloon ascensions were made, mostly in the level below 3 miles.

#### USE OF BALLOONS.

Meanwhile the observatory had extended its work to the exploration of the region beyond the level attainable by kites. This higher stratum was reached by means of small rubber balloons filled with hydrogen gas. The ascensions were made at points in the West, where of the 91 balloons sent up 79 were recovered with good records. These records afford the only direct measures hitherto obtained of the temperature and moisture of the air at very great altitudes, and also furnish information respecting the direction and speed of the wind for the same region. On September 1, 1910, a balloon launched at Huron (S. Dak.) reached the extraordinary height of 19 miles above sea level, the highest point to which a meteorological instrument has ever been carried and afterwards returned safely to the earth.

These observations at great altitudes suggest that possibly the changes in the weather experienced at the surface of the earth originate in the levels between 9 and 15 miles above and that they are propagated downward. The basis of weather forecasting rests upon the fact that, for the most part, changes in the weather advance from west to east. If, instead of advancing horizontally over stretches of hundreds of miles, the seat of weather activity should rest less than 15 miles above us, the failure to improve forecasts based on a horizontal translation of weather conditions can readily be understood.

Experimental work is still being carried on at Mount Weather on practical problems as they arise. Aerial soundings are being made on special days, with a view of determining the height in the free air to which a diurnal wave in the temperature, moisture, and wind conditions can be traced. It is expected that this problem will be solved within the ensuing year.

## AIR DRAINAGE.

In addition to the exploration of the free air by means of kites and balloons, observations on the fluctuations in air temperatures in a cross section of the atmosphere extending from the Shenandoah Valley on the west across the Blue Ridge to the Loudoun Valley on the east have been made. This is a study of air drainage, and is chiefly of interest to horticulturists.

## SOLAR RADIATION.

The observatory has also conducted a series of measurements of the amount and intensity of solar radiation, the degree of absorption of the earth's atmosphere, and the polarization of blue sky light, and an automatically recording device has been installed whereby a continuous record is made of the intensity of the radiation received from the sun and sky upon a horizontal surface. Arrangements have also been perfected to secure measurements of solar radiation at other stations in the western portions of the country.

## SCHOOL OF INSTRUCTION.

A part of the physical laboratory building has been set apart for use of a Weather Bureau school of instruction, wherein it is aimed to teach new employees of the weather service the duties required of them and to give them actual experience in all phases of the work that is required of assistant observers in any part of the service. This new feature of the work at Mount Weather satisfies a want that has been keenly felt during the last 20 years.

The results of the observations and investigations made at Mount Weather are regularly published in the bulletin of the Mount Weather Observatory, a publication devoted to the discussion of the scientific investigations of atmospheric phenomena.

## LIBRARY.

At the central office of the Weather Bureau in Washington is maintained a library of meteorological and climatological literature, in which has been brought together from every part of the world practically all the published material available on these and kindred scientific subjects. In 1896 there were 20,940 books and pamphlets in the library; this number has since been increased to a total of 34,310 volumes.

## AGRICULTURAL STATISTICS.

## CROP-REPORTING SYSTEM.

One of the first undertakings of this department soon after its creation in 1862 was the adoption of a crop-reporting system for the purpose of ascertaining and publishing monthly information con-

cerning the acreage, the condition of the growing crops, and, soon after harvest, of ascertaining the production and value of the principal crops of the year. It was in charge of the Division of Statistics, now a bureau.

For many years this system remained unchanged, until about 1896 a corps of township correspondents was established as a part of the crop-reporting system to duplicate in form the monthly reports made by county correspondents and State statistical agents.

Late in the nineties an important improvement of the system then existing was inaugurated by the employment of a corps of field agents, each one of whom was to cover several States, throughout which he was to travel constantly, so as to be in personal touch with crop conditions and other subjects for which he was to make monthly reports. The improvement of the crop-reporting service due to this innovation was very great and has been increased from year to year by the employment of more field agents, by reducing the area covered by them, and by their increasing skill and accuracy in observation and estimate.

Previous to the summer of 1905 the monthly crop report was made by the chief of the Bureau of Statistics, perhaps after some discussion with members of the office force and during a very few years with one or more of the field agents.

For several years before 1905 the system had improved, but in the year mentioned it broke down in a manner that had hardly been supposed to be possible. The use of the information of the monthly crop report during the growing season, in advance of its publication, had always presented temptation to those in possession of the information to use it in taking advantage of the speculative market in produce exchanges, but the men who could have made such information available had always been trusted and no breach of trust had ever been established against anyone. Besides this, the circumstances under which the crop reports were made were such as to be regarded as making the premature surreptitious private use of the report practically impossible without prompt discovery.

In the spring of 1905 it was discovered that one of the employees engaged in the crop-reporting service in the bureau office had been secretly anticipating the crop report by speculating in produce exchanges in association with other men to whom he had prematurely divulged the report. This caused radical changes in the method of preparing this report and in the circumstances under which the work was done. A crop-reporting board was established, composed of the chief of the bureau as chairman and four other members, whose services were brought into requisition each crop-reporting day from the statisticians and officials of the bureau and the special field and State statistical services. The personnel of the board was changed

monthly; the meetings were held in the office of the chief of the bureau, which was kept locked during sessions, no one being allowed to enter or to leave the room or the bureau, and all telephones being disconnected.

The procedure at the meetings of the board is now substantially as it was in the beginning. When the board has assembled, reports and telegrams regarding speculative crops from State and field agents, which had been placed unopened in a safe in the office of the Secretary of Agriculture, are delivered by the Secretary, opened and tabulated, and the reports by States from the several classes of agents and correspondents relating to all crops dealt with are brought together in convenient parallel columns on final tabulation slips.

The board is thus provided with several separate estimates, covering each State and each separate crop, made independently by the respective classes of correspondents and agents of the bureau, each reporting for the territory or geographic unit with which he is thoroughly familiar. Abstracts of the weather conditions in relation to the different crops by States are also prepared from the weekly bulletins of the Weather Bureau.

With all these data before the board, each individual member computes independently on a separate slip or final computation slip his own estimate of the crop condition or yield of each crop or of the number, condition, etc., of farm animals for each State separately. These results are then compared and discussed by the board under the supervision of the chairman, and the final figures for each State are decided upon.

It has been interesting to note how often the reports of the different classes of correspondents and agents are very nearly identical and how closely the figures arrived at independently by the individual members of the board agree. The estimate by States, as finally determined by the board, is weighted by the acreage figures for the respective States, so that the result for the United States is a true weighted average for each subject.

The present method of making the crop report by a board under the circumstances that surround and confine this board is undoubtedly proof against any premature use of the crop report and has deservedly won the confidence of the public.

In order that information contained in the crop reports may be made available simultaneously throughout the entire United States, they are handed at an announced hour on report days to all applicants and to the Western Union Telegraph Co. and the Postal Telegraph-Cable Co., which have branch offices in the Department of Agriculture, for transmission to the exchanges and to the press. A multigraph statement, also, containing estimates of condition or of



computed or actual production, together with the estimates of former years, is prepared and sent immediately to exchanges, newspapers, and individuals.

Shortly after the issuance of the report it is published in the *Crop Reporter*, an eight-page publication of the Bureau of Statistics under the authority of the Secretary of Agriculture.

#### LISTS OF CORRESPONDENTS.

Besides adding the highly important field service to the crop-reporting system, the Bureau of Statistics has built up 15 separate special lists of correspondents, none of which existed 16 years ago, who are called upon from time to time for information regarding various crops, farm animals, and many subjects relating to agriculture.

One of the prominent lists is composed of about 50,000 farmers who are depended upon for various special reports. There is another list of special correspondents on whom dependence is placed for price reports, another for veterinary reports, another for reports relating to live stock on the farm; still another list of correspondents has the specialty of reporting on live stock at market centers. There is a large list of correspondents in mills and elevators. A special list of correspondents is used to collect certain information for each of the crops of tobacco, potatoes, cranberries, broom corn, hops, peanuts, beans, and apples.

If the number of correspondents in these special lists is added to the number of the regular crop correspondents, the total is about 135,000.

#### VARIOUS SPECIAL REPORTS.

In addition to the regular monthly crop reports, information has been collected and published each month during recent years regarding prices paid to farmers for their leading products, and many special inquiries have been made and their results published, a few of which may be mentioned: Stocks of potatoes in the hands of growers and dealers at specified dates; monthly marketings by farmers of certain leading products; wages of farm labor; values of land and average size of fields upon which corn and wheat are grown; the cost of producing corn, wheat, and oats; causes of damage to leading crops and the relative extent of each cause. The list could be much extended. Results of some of the special investigations are published in bulletins or circulars as well as in the *Crop Reporter*.

#### THE CROP REPORTER.

The *Crop Reporter* was first published in May, 1899. It has been published monthly since that date and has doubled in size—from 4 to 8 pages. Besides being the medium of the publication of the

bureau's regular monthly reports, it contains the results of such special inquiries and studies as can be contained therein. It is supplied gratuitously to all who request it. Its principal circulation is among the farmers, and 175,000 copies of each number are now issued.

Prior to 16 years ago, bulletins and circulars on different agricultural statistical subjects had been issued by the then Division of Statistics; but during the 16 years the former division and present bureau have prepared 91 bulletins and 28 circulars.

The increase in the quantity of work accomplished by the Bureau of Statistics during the past 16 years is difficult to arrive at, but it has been very great. The growth of the domestic crop-reporting service, the large number of special inquiries and studies made, the enormous increase in the statistical correspondence of the office, and the preparation of bulletins and circulars may be conservatively regarded as having resulted in a net increase of not less than 400 per cent in the work of the bureau as compared with the volume of work at the beginning of the 16-year period, with an increase of only 21.8 per cent in the office force.

#### AGRICULTURAL ECONOMICS.

The Division of Production and Distribution has developed a scope of work in directions heretofore little, if at all, explored. It has created a general survey of agricultural conditions and accomplishments in the United States composed of the more important elements of production in quantity and value; of national surplus, deficiency, and consumption; of farm wealth and labor; and of economic achievement and agricultural progress.

The production of important agricultural commodities by the principal countries of the world below and above their respective requirements for consumption, the sources of the supply of such commodities to deficient countries, and the destination of the surpluses of exporting countries, together constitute a subject of unceasing popular interest which is receiving much attention in this division.

The historical aspect of the agricultural production of the United States in particular products and of the surplus or deficiency with regard to domestic consumption has occasioned much painstaking and original work.

The transportation of agricultural products from farm to consumer by wagon, rail, and water, and the costs and methods of marketing are subjects which have been productive of much original work. The division is accumulating much information relating to farmers' associations on the cooperative plan for production, selling, and buying; for fire, live stock, and other insurance; for warehous-

ing; for performing telephone service; and for promoting mutual helpfulness.

Along the lines of work pursued the effort is to establish permanent results of frequent utility to the offices of the department, to the many applicants for information outside of the department, and to the general public. Most of the many bulletins issued from this division are of permanent usefulness and are in current demand; the many special articles that have been prepared for the Yearbook by persons employed in this division are of continuing service; and the threescore statistical tables contributed to the agricultural statistics of the Yearbook are brought down to date annually and are of permanent value.

This is an office of special research and investigation within a field not covered by any office in any other department.

#### DIVISION OF RESEARCH AND REFERENCE.

The Division of Research and Reference was established a few years ago. Its functions are to prepare the monthly report concerning foreign crops, the preparation of articles for the Crop Reporter, the management and care of the statistical library of the bureau, the compilation of statistics on the yield, annual area, and production by countries of corn, wheat, rye, oats, barley, and flaxseed, and the production of coffee for publication in the Yearbook, and the collation of information from publications of great variety on matters relating to agriculture for the purpose of preparing reports and answering special inquiries.

#### CHEMISTRY.

##### MANIFOLD APPLICATIONS OF THIS SCIENCE.

The period from July 1, 1897, to the present time has been one of continuous growth in the activities of the Bureau of Chemistry. During the last 16 years the work has grown in volume and range with steady and rapid progress. It now includes nearly every phase of the application of chemistry to agriculture, to the food and drug industries, and to other manufacturing industries which utilize the products of the farm as raw material.

##### OFFICE QUARTERS.

The contrast between the equipment at the beginning and at the ending of the period is no less marked. On July 1, 1897, the total appropriation for the Division of Chemistry was \$29,500, now it is approximately \$1,000,000. Then the total number of employees was 20, now over 500. Then the division occupied a small building, originally a residence, not well suited for laboratory purposes, consisting of nine rooms; now the bureau occupies a commodious, fireproof

building, with 6 stories and basement, of approximately 100 rooms, constructed especially for laboratory work. In addition there are 25 branch laboratories in cities throughout the country in Government buildings or in suitable rented quarters. All the laboratories both in and out of Washington are equipped with a complete line of scientific apparatus well adapted for the work to be done. In 1901 the Division of Chemistry was organized into a Bureau of Chemistry.

#### METHODS OF ANALYSIS.

In the application of chemistry to agriculture the first and most important step is to develop methods of analysis. This foundation work has been done in cooperation with the Association of Official Agricultural Chemists, which is composed of the official chemists of the United States.

#### EFFECT OF ENVIRONMENT.

Studies on the effect of environment on the composition of grains and sugar-producing plants have been made by the Bureau of Chemistry and the Bureau of Plant Industry in cooperation with several experiment stations.

#### SIRUP INVESTIGATIONS.

In 1903 a study was begun of the methods of making a better table sirup from the ordinary sugar-producing plants, such as the maple tree, sorghum, and sugar cane. The work was directed toward ascertaining methods whereby the product could be made purer, better, of a more pleasing appearance, with less tendency to crystallization, and have a greater resistance to fermentative processes.

The manufacturing problems were taken up at Waycross, Ga., where a model sirup factory was erected, a special appropriation by Congress having been made for that purpose. Four important problems were solved:

(1) By arranging two mills tandem, each mill consisting of three rolls, the amount of juice extracted from the cane was practically doubled over the quantity usually extracted by the old-fashioned two-roll mill generally used throughout the cane-producing sections of the country. This is of the utmost importance to economical agriculture, since it is evidently most wasteful for the farmer to produce by scientific methods and hard labor a larger crop, half of which is wasted in the process of manufacture.

(2) In addition to the great saving by extracting practically all the juice from the cane, other economies in the process of manufacture were worked out. One of the principal problems solved was that of

utilizing the bagasse—that is, the residue of the cane as it leaves the mill—for fuel. The results of the work show that the bagasse can furnish a large part and in some instances all of the fuel necessary not only to drive the mill and press the cane, but also to evaporate the juices to the condition of sirup.

#### TRADE WASTES.

Important studies have been made on the effect of smelter fumes on farm crops, forests, and farm animals, and the data gathered have been used by the Department of Justice in protecting agricultural interests from such injuries. In a suit brought by the State of Georgia to enjoin certain Tennessee smelters from destroying their forests, the use of this information resulted in the smelters being forced to condense the fumes. An experiment made to determine the possibility of making sulphuric acid from this waste was very successful, and the Tennessee copper companies are at the present time producing from 100 to 300 tons of sulphuric acid a day. This total output is used for making reverted phosphate and has greatly reduced the price of this fertilizer. Thus a dangerous and devastating waste product is now utilized to the mutual benefit of the smelters, the forests, and the farmers.

The scientific demonstrations of the extent of the injury caused by such trade wastes, not only to forests, but also to irrigation streams, farm crops, and animal life, has led the Department of Justice to compel the western smelters near Government land to install devices for the condensation of the fumes, to the mutual benefit of all concerned.

#### INSECTICIDE INVESTIGATIONS.

The chemical examination of insecticides and fungicides has been a potent factor in improving the purity of products now sold on the market. Some idea of the value of such work to the farmer is gained by consideration of the loss occasioned by the ravages of plant diseases and insects. Experts have estimated that there is a loss of 20 per cent from these two sources, which, when applied to the farm crops of 1911 valued at \$5,367,000,000, would indicate a loss of about \$1,000,000,000. Probably one-third of this enormous sum could be saved by the proper application of insecticides and fungicides of the requisite strength and purity. Any inferiority in the quality of these materials means the additional loss of the labor in applying them.

The early studies of this subject showed that many of the insecticides on the market were of practically no value whatever, owing to the fact that they contained little or no active ingredients. Other

insecticides which contained some active ingredients were adulterated by the addition of inert substances for the purpose of increasing the bulk to such an extent that they were of no value whatever.

As a result of the data secured by these investigations an insecticide and fungicide law was passed and approved April 26, 1910, which has greatly improved the conditions. Now it is a violation of law to ship in interstate commerce for sale any insecticide or fungicide which is adulterated or misbranded in any particular. A farmer in buying a supply to protect his crops can be reasonably sure he is getting exactly what he asks for and what he pays for. The insecticide laboratory of this bureau does a large part of the analytical work on the samples collected for the enforcement of the law. This laboratory, which conducted the investigations previous to the enactment of the law, did valuable pioneer work in developing methods for the analysis of these products. No methods of analysis had ever been worked out for many of the insecticides.

#### COMMERCIAL FEEDING STUFFS.

An exhaustive study of the various feeding stuffs on the market was completed in 1908, and the results published in Bulletin 108. This study furnished valuable data for the information of purchasers of feeding stuffs and for further studies of the nutritive value of the various materials used for stock foods. It also furnished information that has been of great value in the enforcement of the provisions of the Food and Drugs Act of June 30, 1906, which apply to these products. A study of the feeding value of various cereals was made and the results published in Bulletin 120. The chemical data secured from this investigation has been of value in agricultural studies of the best methods for increasing the nutritive value of various grains.

#### FARM PRODUCTS AND WASTES IN MANUFACTURING INDUSTRIES.

From an economical standpoint the investigations of the Bureau of Chemistry relating to the utilization of farm products for paper making, tanning, denatured alcohol manufacture, turpentine and rosin industries, and the destructive distillation of wood products are of the utmost practical importance not only to the farmer, but also to the manufacturer and to the consuming public.

#### PAPER AND LEATHER MAKING MATERIALS.

In no industrial enterprise is there greater opportunity for conservation than in those agricultural-chemical industries, tanning and paper making. Not only are large quantities of raw materials totally unused, but those which are consumed are not so fashioned that

articles of the highest utility are produced. National reserves are being sacrificed in the wasteful production of inferior products. American paper is beautiful in appearance, and American shoes are tastefully made, but too frequently both lack durability and utility.

These investigations have pointed out the ways in which better leather and paper may be made at less expense. It has been shown that certain operations of tanning—notably bleaching, adding foreign material, and scraping off the surface of the leather—are not only useless, so far as the quality of the leather is concerned, but are positively harmful to it, and make it cost more. It is important that these facts should be more generally known, in order that the squandering of the national reserves may be curtailed and the people protected from inferior products.

Investigations in progress have shown that it is practicable to reduce the weight or bulk of paper used in this country from 10 to 25 per cent. It has been demonstrated that lighter and thinner papers can be made that are in every way superior to those now generally used. The annual cost of paper can be reduced from \$2,000,000 to \$3,000,000, and the equivalent in raw materials and labor conserved.

The leather and paper laboratory is in a position to propose specifications for paper for various purposes, and to show how the cost of paper may be reduced and the quality improved. In several instances the saving on mailing charges alone has paid the extra cost of higher grade papers suggested by the leather and paper laboratory.

#### PRODUCTS OBTAINED BY THE DESTRUCTIVE DISTILLATION OF WOOD.

Extensive investigations have been made by the Bureau of Chemistry looking toward the recovery by distillation of turpentine from dead trees, sawdust, stumps, and other refuse of the lumber industry. Owing to the constantly widening field for the use of turpentine and the gradual reduction of the supply of gum spirits of turpentine the price has steadily increased. As a result the adulteration of turpentine has been all too common. The results of the investigations have been published in Circular 36 and in Bulletins 135 and 144.

It has been demonstrated that by utilizing the stumps, dead trees, sawdust, and other waste material of the lumber industry not only all the turpentine used in this country can be profitably produced, but that all the tar pitch, rosin spirits, rosin oils, methyl alcohol, acetate of lime, and acetone can be extracted from the same waste products. In addition there could be material left for making large quantities of ethyl alcohol, paper, oxalic acid, and other chemicals. The commercial importance of these facts together with processes of manufacture are fully set forth in Bulletin 144.

## DENATURED ALCOHOL.

In 1906 Congress passed a law providing that domestic alcohol may be withdrawn from bond without the payment of an internal-revenue tax, for use in the arts and industries and for fuel, light, and power, on condition that it shall have been denatured by the admixture of some material which unfits it for use medicinally or as a beverage. In 1908 the Bureau of Chemistry began an investigation for the purpose of demonstrating the manufacture of denatured alcohol on a scale suitable for utilization by the farmer or associations of farmers. A model distillery was erected and operated. Various waste farm products were used in an experimental way to determine the manufacturing process to be used in each and to find out what wastes could be profitably used. A number of State experiment stations sent men to be instructed in the operation of the plant and in the processes of distillation, in order that they would be in a position to assist the farmers in their respective States to equip and operate distilling plants. Valuable data as to the yield of alcohol from various farm products were secured. The results of this extensive investigation have been published and will be useful in the development of the industry.

## TESTING CONTRACT SUPPLIES.

On July 1, 1903, a contracts laboratory was organized in the Bureau of Chemistry for the purpose of applying chemical and physical tests to supplies furnished by contractors to this and other Government departments.

Large quantities of inferior goods have been rejected and the contractor required to furnish others of standard quality. Large quantities of supplies are tested for the Isthmian Canal Commission, the Post Office Department, the Government Printing Office, and in smaller quantities for other departments. In one instance tests made by this bureau showing that supplies below standard had been furnished by a contractor resulted in the return to the Government of \$100,000 which had already been paid on one order alone.

## WORK FOR OTHER DEPARTMENTS.

In addition to the testing of contract supplies, the Bureau of Chemistry tests a large number of other samples, conducts chemical investigations, and makes sanitary studies for other departments of the Government. Congress has specifically authorized this bureau to make chemical investigations for other departments when requested to do so by the heads thereof. Life preservers have been inspected at the request of the Department of Commerce and Labor to determine their



buoyancy, rate of water absorption, and the material from which they are made. Examinations have been made of samples of air, water, and fish food for the Bureau of Fisheries. Investigations have been made for the Treasury Department in reference to the classification of various goods for dutiable purposes. At the request of the Attorney General, investigations have been made of the effect of smelter fumes on vegetation. These are merely a few illustrations of a large number of investigations that have been made at the request of other departments.

#### DRUG INVESTIGATION.

On March 1, 1903, a drug laboratory was established in the Bureau of Chemistry for the purpose of studying chemicals and drugs. Valuable results have been secured. Extensive investigations of chemical reagents have been made with the view of securing more reliable chemicals for analytical work. Data have been collected for use in establishing standards.

The work done by the drug laboratory for the Post Office Department has been of special interest. Examinations have been made of a large number of remedies and fake cures of various kinds at the request of that department to assist in the enforcement of the law to prevent the use of the mails for fraudulent purposes. As a result of this work many worthless fakes have been denied the use of the mails.

#### EDUCATIONAL WORK.

The bureau has emphasized the value of educational work in conjunction with scientific investigations, endeavoring to make the data secured available for agricultural chemists and for other agricultural workers.

In connection with the denatured alcohol experimental work, described in another part of this report, a class in the art of distilling was conducted. Men from various State experiment stations were instructed in the processes of fermentation and distilling by actual experimental work in a model distillery plant, and by lectures by experts on the various phases of the work.

#### FOOD AND DRUGS ACT.

On June 30, 1906, the food and drugs act, commonly called the pure-food law, was passed. Since that time a large part of the activities of the Bureau of Chemistry has been directed toward the inspection and scientific work connected with the enforcement of that law.

## FOOD STANDARDS.

In the appropriation bill for 1903 Congress authorized the Secretary of Agriculture "in collaboration with the Association of Official Agricultural Chemists, and such other experts as he may deem necessary, to establish standards of purity for food products and to determine what are regarded as adulterations therein." In accordance with this authority, I appointed as special agents members of the food standards committee of the Association of Official Agricultural Chemists, and the work of establishing standards was taken up. Later this authority was repealed.

## ENFORCEMENT OF THE FOOD AND DRUGS ACT.

The food and drugs act became effective on January 1, 1907, and the actual work in connection with the enforcement of the law began on that date. The first step was to organize a force to handle the various phases of the work. The organization includes: (1) Inspectors who procure samples for analysis and information regarding the manufacture and sale of food and drugs; (2) chemists who analyze samples and make scientific investigations of problems relating to the composition and adulteration of food and drugs; (3) the Board of Food and Drug Inspection, whose duties are to consider all questions arising in the enforcement of the food and drugs act upon which the decision of the Secretary of Agriculture is necessary, to consider correspondence involving interpretations of the law and questions arising under the law, and to conduct hearings based upon alleged violations of the food and drugs act.

The enforcement of the law proceeds along two lines: First, products imported into the United States from foreign countries; and, second, products manufactured or sold in the District of Columbia or the Territories, introduced into interstate commerce, or exported from the United States.

In the case of imported foods and drugs no prosecutions are made. The effort of the department is confined to preventing the importation of adulterated or misbranded goods and causing their reshipment beyond the jurisdiction of the United States. This work is done through branch laboratories which are located at the leading ports of entry, where inspection is made of all food and drug products that enter the United States.

In the case of goods shipped into interstate commerce, or manufactured or sold within the District of Columbia or the Territories, the procedure of inspection is necessarily different. The inspectors visit all sections of the country to secure samples for analysis and such information as may be required by the department. The duties of the inspectors are as follows: (1) To investigate the wholesale and

retail market and obtain samples of foods and drugs shipped in interstate commerce. (2) To inspect manufacturing establishments and secure information in regard to the nature of the foods shipped in interstate commerce. (3) To investigate the manufacture and use of substances which are or may be employed for the adulteration of foods and drugs and methods of preparation which may lead to the damage or deterioration of foods and drugs, or to the use of improper materials in their manufacture. (4) To inspect foods and drugs imported at ports where branch laboratories have not been established. In addition to these duties, special investigations are frequently made by inspectors concerning important questions of sanitation and processes of manufacture.

Samples are shipped to the laboratories at Washington or to one of the 22 branch laboratories which are located at the principal ports of entry and the leading commercial centers.

When goods are found that are in violation of the law, the dealer or shipper is given an opportunity to appear before the Secretary of Agriculture, the Board of Food and Drug Inspection, or such official as may be designated, and present evidence in reference to the question at issue. If after the hearing it appears that the law has been violated, the board makes the appropriate recommendation to the Secretary of Agriculture, who certifies the fact to the proper United States attorney through the Attorney General, together with the necessary information regarding the case. It is then the duty of the district attorney to prosecute the case in the United States district courts.

The law also provides that adulterated or misbranded food or drugs sold or offered for sale in the District of Columbia or the Territories, imported, delivered for export, or introduced into interstate commerce may be seized and disposed of by destruction or sale, as the court may direct.

#### INVESTIGATIONS UNDER THE FOOD AND DRUGS ACT.

In addition to the chemical analysis of samples taken in the enforcement of the food and drugs act, a great deal of work has been necessary in the way of investigating manufacturing processes and trade practices in many classes of food and drug products. A considerable portion of the time of the analysts of the bureau has been devoted to research work along these lines. In the scope of this report it is only possible to refer in a general way to a few of the important studies. The investigations have two general objects in view: (1) To secure data on which to base action under the food and drugs act. (2) To show manufacturers and dealers how they can prepare, pack, and ship their products in such manner as to increase their quality and

purity and bring them up to a standard that will be in harmony with the law.

Among the important scientific investigations which have resulted in direct action under the food and drugs act may be mentioned that of the shellfish industry. In collaboration with the Oyster Packers' and Growers' Association, a number of experimental shipments were made on a commercial scale, oysters being taken from several localities of the United States and shipped by the different methods in ordinary practice. Chemical and bacteriological examinations were made of the oysters before and after shipping. Action was taken to stop practices in washing, packing, and shipping which were shown to be detrimental to the product. Extended investigations have also been made of the pollution of oyster beds from sewage, and action has been taken to prevent the shipment of oysters from such beds.

The effect of cold storage on various food products has been the subject of extended study, and many valuable data have been secured.

As a result of other investigations, seizures and prosecutions have been made of a long line of food and drug products, among which may be mentioned eggs well advanced in decomposition which are broken and sold in bulk in a frozen condition, figs, olives, and various kinds of dried fruit, and flour badly infested with insects. Coffee glazed with chrome yellow, macaroni colored with a poisonous coloring matter for the purpose of simulating the rich color given by eggs, and flour bleached by nitrogen peroxid for the purpose of simulating the white color of the patent flour from certain wheats are other examples.

The milk supply received from neighboring States has been investigated in a number of large cities, and several successful prosecutions have been maintained for the shipment in interstate commerce of milk adulterated by watering, skimming, or prepared in such insanitary surroundings that it was not suitable for consumption.

Important work has been done toward prohibiting the shipment in interstate commerce of misbranded and adulterated stock feed, mineral waters, flavoring extracts, dairy products, sugar and molasses, medicated soft drinks, vinegar, drugs, fake cures, and poisonous colors. The few illustrations suggest the many lines along which the work is directed.

#### CONSTRUCTIVE SCIENTIFIC FOOD WORK.

It has been found that by far the larger number of food manufacturers and dealers desire to comply fully with the law and to handle only pure and standard products. Many of them, however, owing to lack of technical knowledge or suitable equipment or adverse local conditions, have experienced difficulty in reaching the

high standard necessary to fully meet the requirements of the law. The pure-food board has undertaken, in a number of lines where the difficulties seemed greatest, to work out methods by which the product could be properly controlled and to demonstrate to the manufacturers how they can put on the market goods that are of the required standard. Trained experts have gone into the factories and studied the problems involved in the manufacture, the packing, the shipping, and the marketing of the products. The industries in which this work has been done have cooperated to the fullest extent with the bureau and have eagerly adopted improved methods that have been pointed out to them.

This constructive work naturally follows the police work under the law. It has been possible only to make a good beginning with our limited appropriation, but the results already attained indicate that this work can be extended with advantage to manufacturers, dealers, and consumers of food products.

Along this line an investigation of methods for preparing and shipping poultry and eggs in order to prevent deterioration is in progress. The industries concerned are bringing their problems for solution, and are offering the most hearty cooperation in furthering the work. The improved methods evolved have not only prevented losses, but have improved the quality of the product. The cooperators include not only associations of poultry dressers and merchants, but also railways, refrigerator transportation companies, and cold-storage warehousemen. The results so far attained have been most gratifying and still further improvements are expected.

Another important work along this line is being conducted in cooperation with the canning industry. A study has been made of the material to use in the manufacture of the can, and the degree of temperature and length of time that should be given in processing in order to get the best result in the finished product. An experimental factory has been erected and valuable data for improving the methods of canning have been secured.

Experts have been sent to factories to show how different food products could be put up and kept indefinitely without the use of any chemical preservatives. A study was made at Gloucester, Mass., of the cause of reddening of dried cod and other salt fish. Methods were worked out for improving the sanitary condition of the water supply and of the fish factories, which resulted in less infection and resultant spoilage.

#### RESULTS OF THE FOOD AND DRUGS ACT.

There has been a marked improvement in the food and drug supply of the Nation as a result of the enactment and enforcement of the pure food and drugs law that has been of great benefit to the indus-

tries involved, as well as to the consuming public. No longer do the honest manufacturer and dealer have to compete on uneven terms with the misbranded and cheapened product of the dishonest competitor. The law prevents misbranding on the one hand and adulteration on the other. The product of low grade must be sold for what it is, and can not pass under the colors of a higher grade to the deception of the buyer and unfairness to the competitor.

As an illustration of the benefits derived from proper branding may be mentioned the use of medicines that contain cocaine, morphin, alcohol, and other habit-forming drugs.

The adulteration feature of the law protects the consumer from added injurious substances, from any manipulation that lowers the strength or quality, and from carelessness in manufacturing, packing, or shipping that results in the contamination of the product. The better element in all the industries affected have cooperated with the department in bringing about a strict enforcement of the law, and the bureau is now making preparations to still further aid the industry in solving the technical problems involved in the improvement of the products.

#### OFFICE OF PUBLIC ROADS.

##### PROGRESS IN USEFULNESS.

During the past 16 years the Office of Public Roads has grown from a small organization with an annual appropriation of \$8,000 and employing 7 persons to a thoroughly developed organization with 165 permanent and temporary employees and an annual appropriation of \$202,120. There is also an appropriation for the current year of \$500,000, made by Congress to be expended under the direction of this department on post roads. It is provided that in order to avail themselves of this appropriation the States or localities interested shall contribute \$2 for every \$1 contributed by the National Government. The Department of Agriculture, through its Office of Public Roads, will thus direct the expenditure of \$1,702,120 this year.

During the fiscal year 1896-97 the office directed the construction of 7 object-lesson experimental roads, while during 1911-12 there were built 31 object-lesson roads involving 400,775 square yards of surfacing. From 1897 to 1912, inclusive, 343 object-lesson and experimental roads have been constructed. It has been found that object-lesson roads built under the direction of engineers from the office are a most effective method of carrying information concerning standard construction to the various localities. The cost of construction is borne by the localities in which roads are built. The

number of roads built each year by the office from 1897 to 1912, inclusive, is as follows:

1897.....	7	1906.....	17
1898.....	10	1907.....	16
1899.....	4	1908.....	18
1900.....	7	1909.....	57
1901.....	14	1910.....	49
1902.....	15	1911.....	52
1903.....	8	1912.....	31
1904.....	17		
1905.....	21	Total.....	343

The activities of the office reflect, in a measure, the progress and present condition of the road movement in the United States. Sixteen years ago only four States had passed State-aid laws and established State highway departments to direct the work, viz, New Jersey, Massachusetts, Connecticut, and California. At the present time, however, the principle of State-aid has been adopted in 40 States.

The Office of Public Roads was originally the Office of Road Inquiry in the Department of Agriculture, and was established under authority of an act of Congress of March 3, 1893, with an appropriation of \$10,000. It was provided by law that the Secretary of Agriculture should make inquiries in regard to systems of road management throughout the United States, make investigations in regard to the best methods of road making, prepare publications, and assist agricultural colleges and experiment stations to disseminate information concerning roads.

#### EXPERIMENTS IN CONSTRUCTION AND MAINTENANCE.

For the fiscal year 1912 Congress appropriated \$10,000 to conduct field experiments in various methods of road construction and maintenance and to investigate various road materials and preparations. This appropriation has enabled the office to conduct a series of independent experiments along comprehensive lines.

#### TESTING ROAD MATERIALS.

In December, 1900, a laboratory was established in the Bureau of Chemistry for the testing of road materials. This laboratory was transferred in 1905 to the Office of Public Roads, where its present organization has been developed and perfected. From 1900 to June 1, 1912, 6,060 samples of road materials have been tested, including rock, gravel, sand, slag, clay, brick, cement, iron, steel, asphalt, oil, tar, rubber, and various other substances.

Much has been accomplished in the development of the physical tests of rock for road building, and the methods here adopted are now practically standard throughout the United States.

Research work in concrete has been productive of promising results. The properties of oil-mixed Portland cement concrete have been investigated, and indicate this material to be one of merit for damp-proofing purposes. A public patent has been granted for this material, so that any one may now use it without the payment of royalties. Measurements of the expansion and contraction of concrete while hardening, which are of value to concrete engineers, have aroused considerable interest and serve to explain certain phenomena in connection with concrete construction.

Experiments have been conducted to determine the efficiency of oils, tars, asphalt, and other preparations used for the purpose of preventing dust and preserving macadam roads under modern traffic conditions. Laboratory experiments have been accompanied by service tests and experiments in the field. The office has also conducted investigations to determine the feasibility of building sand-clay and burnt-clay roads in the Southern States and in the Mississippi Valley. Such construction has been found to be practicable for certain regions where materials are available and climatic conditions favorable.

Successful efforts are constantly made to bring about a more general use of the split-log drag in the maintenance of earth and gravel roads.

#### MODELS OF TYPES OF ROADS.

In order to better demonstrate the fundamental principles of road construction, the office has built a number of models of various standard types of roads and bridges and of road-building equipment, including road machines, rollers, and crushers. A set of models was first exhibited at the Alaska-Yukon Exposition. Since that exposition closed, similar exhibits have been shown in many parts of the United States through the medium of expositions and by means of exhibit trains operated by various railroad companies. The cost of making such demonstrations has been paid by the expositions or by the railroad companies interested. Lecturers and demonstrators from the office have accompanied exhibits and made them to a large degree schools in road building.

#### TRAINING HIGHWAY ENGINEERS.

Realizing the need for trained highway engineers, the office inaugurated a plan in the year 1905 whereby a number of graduates in engineering are appointed each year from engineering schools and colleges after competitive examinations. These men are given



a thorough training in road building, while they also render practical service to the Government. An efficient corps of highway engineers is thus prepared to carry out road building along correct lines. A number of engineers from the office are already connected with State and county highway departments in various parts of the United States, while several of them are constantly retained in the Government service.

#### INVESTIGATIONS.

The office has investigated the decomposition of rock powders under the action of water and discovered important facts with reference to their use as road materials. Investigations into the corrosion of iron and steel culverts and fences have also been productive of important results, and the matter of protective coatings has been extensively studied.

#### STANDARD SYSTEMS.

In May, 1907, the office inaugurated a project designed to introduce improved standard systems of construction, maintenance, and administration of roads into various counties throughout the United States. Under this plan experienced engineers are assigned to make thorough investigations on all phases of the road work of various counties and to prepare exhaustive reports with plans, estimates, and recommendations. This method has already resulted in the saving of thousands of dollars to the counties where such model systems have been adopted.

#### OFFICE EQUIPMENT.

Thorough and systematic methods of organization have been introduced into the administration of the office. Each employee is given specific duties to perform, and a careful system of reports and records is kept of work done and expenditures made on every project. The most approved system of filing is in use, and a library has been established containing a complete collection of periodicals, manuscripts, pamphlets, reports, and books on all phases of road work. This library is being added to constantly. Fifty-nine periodicals are now regularly received, of which 44 are donated.

The office has in its files 8,237 photographic negatives and about 5,000 lantern slides illustrating nearly every item of road improvement. These slides are extensively used by representatives of the office in lecture work. During the year just closed 1,135 lectures were delivered by representatives of the office, nearly all of which were illustrated with lantern slides.

From 1897 to the present time the office has issued 28 bulletins, 73 circulars, 10 farmers' bulletins, 19 Yearbook extracts, 15 annual reports, and 1 lecture syllabus; a total of 146 publications.

## ECONOMIC BENEFITS OF ROAD IMPROVEMENT.

Investigations are now under way to determine the economic benefits resulting from road improvement and the particular relation of such improvement to agriculture. It is evident that when \$142,000,000 constitutes the annual expenditure for road purposes in this country, improved business management in our road work is imperative. Much statistical work is therefore carried on, particularly on the subjects of mileage, cost, and financing. The method of financing road construction by bond issues is becoming very common and is receiving considerable attention from the office, with the view to giving appropriate information to those who contemplate such methods of road financing. In order that the office may be kept in close touch with road work, a collaborator is employed in each State to act as representative and corresponds monthly with the office.

## MILEAGE OF ROADS.

An investigation was begun in 1904 to ascertain the mileage of improved and unimproved roads, rates of levy, and sources of revenue in every county in the United States. This work was finished in June, 1907, and shows that there were then over 2,150,000 miles of roads in the United States, of which only 7.14 per cent were improved. The expenditure in money and labor for that year amounted to nearly \$80,000,000. A similar investigation begun in 1909 shows that there were, in 1909, 2,199,645 miles of public roads in the United States, of which 190,476 miles, or 8.66 per cent, were improved. Information in regard to expenditures on all the public roads in the United States was collected during the year 1911. This investigation shows that the expenditures for that year amounted to approximately \$142,000,000.

## CLEARING HOUSE FOR ROAD QUESTIONS.

The Office of Public Roads is alive to the present problems of highway development, and its efforts are constantly and systematically directed toward their solution. The normal development of the office during the past 16 years has placed it in such a position that it may now be called a clearing house for all road questions.

OFFICE OF **EXPERIMENT STATIONS.**

## EXTENSIONS OF WORK.

During the last 16 years the Office of Experiment Stations, which was established primarily to represent the department in its relations with the State agricultural colleges and experiment stations, extended its field of work to include supervision of experiment sta-

tions under the direct control of the department in Alaska, Hawaii, Porto Rico, and Guam. It also undertook work having as its object the promotion of farmers' institutes and other forms of extension work, and was assigned the management of special investigations in irrigation and drainage.

#### PUBLICATIONS.

The publications of the office, which furnish a fair index of its activities, increased from 39 documents, containing 2,600 pages, in 1897, to 85 documents, containing 4,761 pages, in 1912.

The Experiment Station Record, which reviews the world's literature on scientific agriculture for the use of investigators in this line, in 1897 consisted of one volume of 1,210 pages, containing 1,565 abstracts. In the year ending June 30, 1912, two volumes of the Record were issued, each containing nearly 1,000 pages, and containing in the aggregate 7,800 abstracts. The Record about doubled in size in this time, and the volume of literature reviewed in it more than doubled.

In 1897 a series of popular bulletins, known as Experiment Station Work and published in the Farmers' Bulletin series of the department, was begun, to supplement the Record and disseminate the results of the more practical work of the experiment stations. Up to date there have been issued 70 numbers of this series of bulletins, containing over 600 articles on a variety of topics of interest to the practical farmer.

#### GROWTH OF EXPERIMENT STATIONS.

The growth and development of the experiment stations during the past 16 years is also indicative of the growth of the office during this period. In 1897 the stations employed 628 persons in the work of administration and research, while in 1911, the last year for which statistics are available, the stations employed 1,567 persons in their administrative, research, and other lines of work. Likewise in 1897 the stations had a total income of \$1,129,833, of which \$720,000 represented the Hatch Act, while in 1911 their total income was \$3,662,425, of which \$1,440,000 was received from the United States under the Hatch and Adams Acts. In other words, the employees and income of the stations more than doubled during the period named.

#### THE ADAMS ACT.

The Adams Act, passed in 1906, doubled the Federal appropriations to the State experiment stations and greatly increased the duties of the office in relation to the use of these funds for research work. The legality of the expenditures is so largely dependent upon the

character of the investigation that the supervision of the funds becomes in a large measure a supervision of the investigations and experiments as far as their character, original features, and continuity are concerned. Since the passage of the Adams Act this office has considered and approved over 600 projects outlined and submitted by the stations to be carried on with the fund provided by the act. Numerous questions arise as to the nature of the work and entail a large amount of correspondence to effect a settlement of the different problems. The Adams fund projects of the experiment stations represent a vast amount of original investigation, and there probably has never been an attempt to supervise research work conducted on such an extensive scale.

#### COOPERATION WITH STATIONS.

The experiment stations during the period under discussion have freely cooperated with this department in numerous lines of work and have been highly instrumental in carrying the benefit of the department's efforts to the different agricultural sections and to the individual farmer. Among the numerous lines of activity which have made marked progress as the result of vigorous efforts on the part of the department and the stations may be mentioned the utilization of lands hitherto unproductive on account of limited rainfall or lack of crops suited to the conditions.

One of the results of this work is the bringing under cultivation of large areas of dry lands and the making regions of deficient rainfall available for settlement. In this connection the introduction of durum wheats by this department and their distribution largely through the stations has been of great value to the Great Plains region and other sections where dry farming is practiced.

Plant-breeding work has undergone a remarkable development during the past 16 years, and in no other field has the work of the department, supplemented extensively by experiment-station effort, met with greater success. The production of improved seed corn has become the rule rather than the exception, and numerous varieties and strains of field, garden, and orchard crops have been originated and distributed. The Wisconsin station has distributed improved tobacco seed, pedigreed barleys, and pure-bred varieties of oats. The Minnesota station has bred a winter rye, hardier and producing greater yields than varieties ordinarily grown, and has originated and sent out a variety each of wheat, oats, corn, and flax, now commercially known and quite widely grown in Minnesota and the adjoining States. The South Dakota station has produced and given to the public some excellent hybrid plums, plum and sand cherry crosses, and hybrid raspberries, in addition to carrying on breeding work with hardy alfalfas and other promising forage crops for the

Northwest. These few examples are given to show the general trend and results of this work. There is not an experiment station in the United States to-day that does not pursue some line of plant breeding either for the purpose of improvement in yield and quality or of adaptation to particular conditions of soil and climate.

The beet-sugar industry of this country was built up practically during the past 16 years. The department aided this industry by the distribution, largely through the experiment stations, of tons of sugar-beet seed with a view to determining where the best beets could be produced and in what sections beet-sugar factories could be operated with profit and success.

Numerous other instances of cooperation between the department and the experiment stations, either prearranged or otherwise, could be given. The stations have followed up closely the department's work on plant introduction, hog-cholera serum vaccination, suppression of bovine tuberculosis, and other phases of work of sectional and national importance.

#### AGRICULTURAL EDUCATION.

In 1897 there were 61 colleges giving instruction to 4,000 students in agriculture; in 1911 the 67 State agricultural colleges enrolled almost 18,000 students in agriculture, and there were also 42 privately endowed colleges giving courses in agriculture. The total income of the land-grant colleges in 1897 was \$5,000,000; in 1911, \$22,000,000, and the total value of their property increased from \$51,000,000 to \$120,600,000.

Very few of the agricultural colleges gave opportunities for graduate study in agriculture prior to 1897, and there was no national graduate school of agriculture. Since then five sessions of the Graduate School of Agriculture have been held under the auspices of the Association of American Agricultural Colleges and Experiment Stations, and 43 of the agricultural colleges now give graduate courses in agriculture. None of the agricultural colleges trained teachers for high schools in 1897; now 40 of them do this. Then none had extension departments; last year they enrolled 169,000 students in correspondence and extension courses in agriculture.

There were 9 agricultural high schools in 1897, 78 in 1912. No public high school then taught agriculture; now 289 of them in 11 States receive State aid for courses in agriculture, home economics, and farm mechanics, Minnesota alone giving \$125,000 a year for these purposes. Over 1,600 other high schools give instruction without State aid.

Agriculture in the elementary schools had hardly been thought of in 1897, whereas now nearly every State in the Union gives some encouragement to such teaching, and 19 require it by law. To pre-

pare teachers for this work 196 normal schools now give instruction in agriculture.

In 1897 the department listed 70 colleges and high schools as teaching agriculture; now the list—an incomplete one at that—includes 2,575 colleges and high schools in the United States.

Prior to 1897 the Office of Experiment Stations had no regular agricultural education service, and it had issued only about two dozen publications relating in any way to agricultural education. Since that time it has issued 123 publications, dealing with all phases of agricultural education, of which hundreds of thousands of copies have been sent to all parts of the country. It has five people giving all of their time and five others giving a part of their time to the promotion of agricultural education. For 17 years the director of the office has been a member of the committee on instruction in agriculture of the Association of American Agricultural Colleges and Experiment Stations, and for all five sessions of the Graduate School of Agriculture he has been dean of the school.

The agricultural education service of the office represents the department in its relations with agricultural colleges and schools at home and abroad, cooperates with other bureaus of the department in educational projects, and lends advice and assistance in every way possible to State and National institutions and organizations for agricultural education.

#### FARMERS' INSTITUTES.

The work of aiding in the development of the farmers' institutes was officially undertaken by the department in 1903 under an act of Congress of that year providing for the appointment of a farmers' institute specialist. His duties as defined by the act were "to investigate and report upon the organization and progress of farmers' institutes in the several States and Territories and upon similar organizations in foreign countries, with special suggestions of plans and methods for making such organizations more effective for the dissemination of the results of the work of the Department of Agriculture and of the experiment stations and of improved methods of agricultural practice." An institute specialist was appointed, who entered upon his duties April 1, 1903.

#### STATISTICS.

Prior to this appointment the Office of Experiment Stations in 1900 had collected information in regard to the status of the institute work of the country, which was published as Bulletin No. 79, and again in 1902 data were gathered and tabulated and published by the office in its annual report. According to that report institutes

were held in that year in 43 States to the number of 2,772, with an attendance of 819,995, and funds were contributed by the State legislatures for institute work to the amount of \$145,650, and there was received from other sources \$17,474. This was the status of the work when the department established the farmers' institute office.

The progress made since then is seen in the report of the institute specialist for the year ended June 30, 1912. During that year institutes were held in all of the States and Territories excepting Alaska, Hawaii, Nevada, and Porto Rico. The total number of meetings was 7,079, covering 9,429 days and composed of 17,760 sessions. The attendance at the regular institutes was 2,483,028, and the amount appropriated for their support was \$516,072, not counting sums contributed by individuals for rent of halls, entertainment of lecturers, advertising, and other local purposes.

As an outgrowth of the general or mixed institute there have developed since 1902 the women's institute, institutes for young people, the movable school of agriculture, the instruction train, the round-up institute, the field demonstration, agricultural picnics, institute exhibits at local and State fairs, the agricultural club, and the correspondence course. Attendance upon these special forms of institute activity in 1912 was 1,476,477, making the total attendance at institutes of every kind during the year 3,959,505. The body of expert lecturers in the employ of the State directors giving instruction in the institutes now numbers over 1,100. No such school of instruction equal either in number and skill of its teachers or in the number of adults attendant upon it exists anywhere else in the world.

#### THE DEPARTMENT'S RELATION TO INSTITUTES.

The work has been along the lines directed in the act authorizing the employment of a specialist. Statistical data and other information respecting farmers' institutes and other forms of agricultural extension both in this country and abroad have been gathered and prepared for publication. Numerous addresses before farmers' associations and in educational institutions have been delivered. Bulletins and circulars upon agricultural extension have been prepared. The proceedings of agricultural associations and conventions have been edited and published. Officials connected with agricultural extension work in the agricultural colleges, fair associations, State libraries, railroad agricultural extension departments, State departments of agriculture, and other associations interested in agricultural extension work have been visited and interviewed. Printed information has been distributed, and the correspondence of the office has been conducted.

The institute specialist has for a number of years acted as secretary of the committee on agricultural extension work of the Association of

American Agricultural Colleges and Experiment Stations, and also as secretary-treasurer of the American Association of Farmers' Institute Workers. He has collected annually for the Association of Colleges and Stations data respecting agricultural extension and has prepared the programs and selected lecturers for the annual meeting of the Association of Farmers' Institute Workers. A large amount of travel has been performed by the institute specialist and his assistant in promoting extension work, and a great number of lectures have been delivered before meetings of agricultural people in both State and National conventions. Numerous addresses and papers have been prepared by the office for publication, and a large correspondence has been conducted. Over 20,000 names of prominent agriculturists in the United States have been listed, representing all forms of extension activity.

#### PUBLICATIONS.

There have been prepared and published as original matter by the Farmers' Institute Office 6 bulletins consisting of 392 pages, 15 circulars of 335 pages, 9 annual reports of 420 pages, 2 separates of 29 pages, and 1 illustrated lecture of 25 pages; a total of 1,201 pages.

There have also been edited in the office 13 bulletins, 1,909 pages; 13 illustrated lectures, 278 pages; a total of 1,368 pages. There have been prepared in the office and are now ready for publication 3 bulletins of 370 pages of manuscript, and there has been edited and sent into the editorial division 1 bulletin, 76 pages.

There have been added to extension literature by the institute office contributions along the following lines: The origin and history of farmers' institutes in the several States; the laws under which the institutes operate; information respecting agricultural education for adults in 25 foreign countries; forms of extension work for agricultural colleges and experiment stations; the names and addresses of farmers' institute directors and lecturers in the United States; form of organization and courses of study for movable schools of agriculture; forms of organization for institutes for women and for young people; reports upon transportation companies of the country as factors in agricultural education; annual report upon the farmers' institute work in the several States with suggestions for its improvement; a series of lectures upon agricultural subjects illustrated by 641 lantern slides; also reports of the proceedings of the American Association of Farmers' Institute Workers, comprising 651 pages, and containing discussions of institute problems by the leading institute directors, lecturers, and educators of the United States and Canada; a translation of the results of agricultural extension work in Belgium, together with papers, discussions, and addresses before meetings of agricultural people in both State and National conventions.

The effort has been to develop forms of extension already in operation, and to introduce new methods for use by State officials



and college-extension directors engaged in agricultural instruction work. During this period the foundation of a permanent system of farmers' institutes has been laid and direction given to the conduct of the work throughout the country.

#### INSULAR STATIONS.

Agricultural experiment stations were established under the supervision of the Office of Experiment Stations in Alaska in 1898, in Hawaii and Porto Rico in 1901, and in Guam in 1908, preliminary surveys having shown the apparent necessity of such investigational institutions in the different regions. The policy adopted at the beginning and maintained ever since was to determine and develop the agricultural possibilities of Alaska, to diversify the agriculture of Hawaii and Porto Rico, and to restore that of Guam to its former importance.

#### ALASKA.

In Alaska, on account of the size of the country and the diversity of conditions, stations have been established at various points along the coast and in the interior valleys. The principal lines of work have been agriculture, horticulture, and stock raising. At Sitka, where headquarters are maintained, horticulture has been given prominence, and not only have varieties of garden vegetables been found adapted to that region but bush fruits have been introduced and are flourishing, apples and cherries have been matured, and hybrid strawberries produced that excel in hardiness and quality any cultivated varieties that have been tested.

In the interior valleys, at Rampart and Fairbanks, grain farming is being especially studied. A majority of the varieties of barley and oats have ripened every year at Rampart since the station was established in 1900, and some varieties of wheat and rye have likewise matured. Last year practically all varieties of cereals ripened. Some hybrid barleys have been produced that for earliness excel any of the introduced ones. Siberian alfalfas have been successfully introduced and have withstood the winter climate for two years. At Fairbanks similar results have been secured, and these two stations represent a large area of land whose agricultural possibilities are by no means unimportant. Potato growing has been given attention at all the stations, and at Fairbanks field yields of over 200 bushels per acre were secured in 1911.

At the station on Kodiak Island attention has been given for about six years to stock raising, and Galloway cattle have been found perfectly adapted to the country, a herd of nearly a hundred head having been maintained almost exclusively on pasture, silage, and hay made from native grasses.

The investigations thus far conducted in Alaska have shown that a considerable amount of agriculture is possible in that country; within limits it is possible to recommend varieties of all the better known vegetables for cultivation in the different regions of the Territory, and the possibilities of cattle raising have been fully demonstrated.

## HAWAII.

In Hawaii the diversification of agricultural industries has been the main problem of the station. Through its efforts a number of new industries have been established and others aided in their development. Investigations showed the possibility of tobacco growing in Hawaii, and several companies and individuals have engaged in it on a commercial scale. One company expects to plant 200 acres of tobacco in 1913.

The rapid development of the pineapple industry in Hawaii owes not a little to the station, and this crop has become second in importance among the agricultural industries of the islands, the estimated pack of canned pineapples of one of the largest companies being 360,000 cases for 1912.

The station has assisted materially in developing a rubber industry in Hawaii, and has shown the possibility of growing cotton on a commercial scale. In this work sea-island and Caravonica cotton are successfully grown as perennial crops, the plants being pruned each year to get the best results.

A very extensive study of the rice crop has been made, and new varieties of better yielding character have been bred and distributed. The method of fertilizing rice was found faulty, and instead of nitrate of soda being used at an actual loss the crop may be doubled by the use of sulphate of ammonia applied when the crop is sown. Next in efficiency is bean-cake meal. Practical methods for the propagation of choice varieties of tropical fruits have been worked out that are being put in practice not only in Hawaii but elsewhere.

The peculiarities of the Hawaiian soils are being studied, and the effects of some of the more unusual soil constituents are being tested. A considerable number of forage plants and other plants of economic importance have been introduced and are receiving wide attention. Insect pests are being studied, and methods for the control of some have been discovered.

## PORTO RICO.

In Porto Rico the problems of diversification of agriculture have been about the same as in Hawaii, where sugar production is the leading industry. The station early took up the problems of citrus-fruit and pineapple production, and the exports of these fruits have

grown from less than \$100,000 in 1900 to over \$2,100,000 in 1911. The station has shown in growing these crops that in Porto Rico at least windbreaks are necessary for citrus fruits and that too much lime in the soil must be avoided in planting pineapples.

The renovation of coffee plantations has been given much attention with promising results, and the value of pruning, fertilizing, and cultivating the trees has been demonstrated. By following these means a renovated plantation was made to more than double the average yield of the island. New varieties of coffee have been introduced, and many of the higher priced coffees of the world are now in bearing and their seed is being distributed for planting.

Much attention is being given to insect pests and fungus diseases, and marked progress has been made in combating them. Windbreaks as conservers of moisture in citrus groves have been found an efficient means of securing conditions favorable for the development of fungi which destroy some of the most troublesome scale insects affecting oranges. A special study has been made of some of the so-called sick soils of Porto Rico, which from chemical and physical composition should be productive but which are almost wholly barren. The causes of their peculiar behavior appear to be biological, and means for their improvement are being worked out.

An effort is being made to improve the live stock of the island, and the station has introduced improved breeds of horses, cattle, swine, and poultry, and the presence of such animals is already apparent in the better grades of stock found in many localities.

#### GUAM.

In Guam from various causes agriculture had fallen to a very low plane and production was much below the food requirements of the island, and the immediate problem has been its improvement. The first efforts were in the securing of better varieties of crops and the introduction of new ones that have proved valuable in other tropical countries. In this the station has been very successful, and a number of forage plants, varieties of corn, vegetables of various kinds, tropical fruits, etc., have been thoroughly established.

Following the demonstration that forage could be readily produced, improved horses, cattle, swine, and poultry have been sent to Guam, and late reports state that they are doing well in their new surroundings. Only one year has elapsed since the stock was sent to Guam, but their presence has already awakened among the people a desire for better animals upon their ranches.

The work before the stations is the same as it was in the beginning—pioneering in Alaska, the diversification of agriculture in Hawaii and Porto Rico, and improving agricultural methods in Guam. Some progress has been made, but much yet remains to be

done. In nearly every locality where stations have been established the results of their work are seized upon and put into practice. The stations are heartily cooperating with the people by furnishing advice, new seeds, etc., and in turn the people are right loyally supporting the stations according to their ability to do so.

#### NUTRITION INVESTIGATIONS.

Sixteen years ago the nutrition investigations of the Department of Agriculture had just passed the organization period and begun the period of development which since that time has been steady and continuous. The purpose of these investigations is to study the use as food of products of farm, ranch, and garden, and to bring the results obtained to the attention of housekeepers, and thus help them in making the best, most rational, and most economical use of available resources.

A great variety of questions have been studied, and the results obtained have been of very decided value to the housekeeper, as well as to the producer of food supplies and those who manufacture, handle, and market them. As a whole the investigations have provided and made accessible a large amount of data regarding the composition and nutritive value of American food materials, their properties, and their uses. Special investigations have been numerous, as is shown by the references which follow.

#### DIGESTIBILITY.

The relative digestibility of bread made from different sorts of flour has been studied exhaustively, the conclusion reached being that coarse flours are somewhat less thoroughly assimilated than fine grades, but as a whole all are well digested and are very valuable foods. Similar studies have been made of the relative digestibility and nutritive value of meat of different kinds and cuts. Whatever the cut, mutton, beef, and other meats were found to be very thoroughly assimilated and valuable sources of protein and energy in the diet. Cheese has been studied exhaustively, and, judged by its thoroughness of digestion and other nutritive qualities, it is to be regarded as a staple food suitable for use in quantity rather than as an article for occasional use. Studies of the digestibility and nutritive value of cereal breakfast foods and other cereal foods, of food and food products, of nuts, and of vegetables of different sorts have also been carried on.

From these and other studies which have been made to learn the thoroughness of digestion of ordinary foods of different sorts prepared in the usual ways average figures have been deduced, with the aid of which thoroughness of digestion can be computed with reasonable accuracy—a great convenience under many circumstances.

## COOKING PROCESSES.

Much time has been given to the effects of various cooking processes on nutritive value and digestibility and to the relative value of different methods of preparing food when judged by quality, palatability, and the labor involved. The results show clearly that laboratory methods can be as profitably used in the solution of such questions as they can be in milling, paper making, dyeing, and other commercial industries.

## DIETARY STUDIES.

Dietary studies have been carried on in homes and in public institutions, which have furnished data of great value regarding the living conditions of the American people and have helped in the formulation of dietary standards which are used as guides in home and institution management. The studies have also furnished information of use in the selection and preparation of foods as well as in providing quantities sufficient for adequate nourishment without undue waste.

## RESPIRATION CALORIMETER.

The respiration calorimeter 16 years ago was in the experimental stage. Since that time it has been perfected and so simplified that it can be operated with ease and made to furnish results of great accuracy. The uses to which it may be put in the study of food problems are very numerous and by no means exhaust the field of its usefulness. A later development of this apparatus is designed for the study of fruit ripening and other problems of vegetable life, a kind of work original with the department and full of possibilities for helping the grower, the shipper, and the handler of fruits and vegetable products, as well as the housewife who uses them. Plans involving cooperation with other bureaus of the department have been formulated which have to do with the ripening of fruits and other vegetable products and the handling and care of animal products.

Studies planned, or already in progress, have to do with the food value of mutton, the relative nutritive value and culinary qualities of different animal and vegetable fats, the use of dried fruits in the diet, the relative ease of digestion of different foods, and other similar work. In carrying out these projects the respiration calorimeter will be used.

## PUBLICATIONS.

Of the 62 technical publications which have reported the results of nutrition investigations, all but 10 have appeared during the last 16 years, as have all but 3 of the 50 Farmers' Bulletins and other popular publications, which have summarized information on food topics in such a way that it might be valuable to the housewife and

the student. The demand for the technical bulletins and nutrition charts has exceeded the supply, while the demand for popular bulletins has grown very greatly, particularly during the last 10 years, and has been so large that over 12,000,000 copies of Farmers' Bulletins on bread, meat, milk, fish, eggs, and other foodstuffs, and their care, preparation, and use in the home, and a correspondingly large number of other popular nutrition documents, have been required to meet it; and the demand is still growing.

This widespread distribution of information pertaining to home problems is equivalent to an increase in the available food supply, since it makes possible a better and more economical use of available resources, and shows how needless waste and loss may be avoided.

Farmers and housekeepers have come to realize that the Department of Agriculture devotes its energies to questions which are fundamental to their interests and that it can and is ready to help them solve their problems. As a result, they turn to the department for help in increasing numbers. This is strikingly the case in all that pertains to food and nutrition. Thousands of letters are received each year from housekeepers, home makers, teachers, students, and others, and, in so far as it can be done, the desired information is supplied, either in printed documents or more directly by letter. The department has been called "the people's university," and as a disseminator of knowledge of farm and home topics it well deserves this name.

#### METHODS FOR STUDYING NUTRITION PROBLEMS.

The development and standardization of methods for studying nutrition problems and the devising of ways in which information that has been accumulated may be best made available to housekeepers and students have been an important part of the nutrition work. What has been accomplished in this way is applicable not only to nutrition, but also to related topics—clothing and shelter—which with nutrition make up the subject of home economics. In this work the department has done something which was recognized by agricultural experts as a public need even before the Department of Agriculture was established. It is evident that those who worked for the founding of the Department of Agriculture had in mind the desirability of studying home problems along with those of the farm, for the first report of the first commissioner of the United States Department of Agriculture, published in 1862, quotes with approval a statement made some 20 years earlier of the objects of a great national Department of Agriculture, which includes household economy as a division of agriculture in its widest acceptance, together with cultivation of the soil, orcharding, gardening, "rural embellishment, and the veterinary art." This is logical, for all food products, most

of the raw materials for clothing, and many of the materials used for shelter are supplied by agriculture, and it is as important to study their use as their production, since the two are interdependent.

The Department of Agriculture not only helps the farmer to make two blades of grass grow where one grew before, but also, through its studies of the use of agricultural products as food, helps the housekeeper in her efforts to make one dollar do the work of two in providing for the family table, so that it may meet the daily requirements for food, accord with the tastes of the family, and be reasonable in cost in proportion to the family income.

#### IRRIGATION INVESTIGATIONS.

Sixteen years ago the farmers of the arid region were just beginning to realize the need of more scientific and technical advice in the solution of their many irrigation problems. The crude laws of the western miner when applied to irrigation were proving a misfit. Water rights were undefined, and water users were left with little protection save through costly and long-continued litigation. Again and again State legislatures tried to grapple with this difficulty, only to find at the closing hours of each session that they did not possess reliable information on which to base remedial legislation pertaining to the use of water for irrigation and other beneficial purposes.

In 1896 water was used on about six and one-third million acres in the West, but little was known of the quantities diverted or of the large losses which occurred in conveying water through earthen ditches to so many farms.

In 1898 Congress granted a small appropriation for irrigation investigations to be used wherever advisable in cooperation with western agricultural colleges and experiment stations. The collection and publication of information pertaining to the use of water in irrigation was accordingly begun, and there can be no doubt but that the expansion and continuity of this work has exerted a marvelous effect on the development of irrigation along right lines during the past 14 years. In that time the States of Nebraska, Idaho, Utah, Nevada, North Dakota, South Dakota, Oregon, New Mexico, and Arizona have adopted modern irrigation codes based to a large degree on the recommendations of this department. In all of the States named, including Colorado and Wyoming, the chaotic state of affairs regarding irrigation which prevailed 16 years ago is giving place to law, order, and system. The water records are being cleared of worthless claims, and valid rights are not only recognized but protected.

#### DISSEMINATION OF INFORMATION.

As conclusions of value were arrived at in regard to the use of irrigation water they were set forth in bulletins which were disseminated throughout the West. The results of these investigations have been

watched closely, and it is believed that they have caused a much better understanding among irrigators of the best methods of applying water, the dangers of waste, and the actual requirements of irrigated crops. As an instance of the reform that has been accomplished in this line, the changes that have been brought about in the use of water in the Modesto irrigation district in California may be cited. In 1904 diversions by the Modesto Canal amounted to more than 13 acre-feet per acre for the land irrigated. In 1912 slightly more than 4 acre-feet per acre were used.

As the work of the investigations became better known frequent requests were made by prospective settlers in irrigated sections for information concerning the possibilities of irrigation in various Western States. To meet this demand a series of bulletins was published providing in concise form such information concerning conditions in each State as was believed to be of value to prospective settlers on irrigated lands. To meet a similar demand which came largely from farmers already irrigating, other bulletins were prepared giving advice as to the best methods and practices employed in the irrigation of crops most widely grown in the West.

Contrasting the small beginnings of irrigation investigations of this department 14 years ago with the present, one finds that the congressional appropriation has increased tenfold and that the work actually undertaken has increased in even greater ratio. The six and one-third million acres which were irrigated under private enterprises in 1896 have increased to 15,000,000 acres, and instead of being confined to the more arid portions of the country it is rapidly extending to practically every State of the Union regardless of the annual precipitation. In Louisiana, Mississippi, and southern Arkansas the rainfall frequently exceeds 50 inches per annum, yet a most remarkable development has taken place in this district in the past 16 years as the direct result of irrigation. In 1911 over 700,000 acres were seeded to rice, all of which were irrigated. This extensive acreage produced in that year over 22,500,000 bushels of rice, for which the growers received over \$18,000,000. Ten years ago prairie lands in Arkansas were held and occasionally sold at \$5 to \$6 per acre. Now the pumping of water from wells and the profitable production of rice under irrigation has increased the price to from \$50 to \$90 per acre.

From the irrigated rice fields of the Gulf States the practice of irrigation has extended eastward throughout the humid region. The department is now carrying on successful cooperative experiments in the States of Alabama, Florida, Georgia, New Jersey, Maryland, Iowa, Minnesota, and Wisconsin. While the data thus far secured are incomplete they are sufficient to indicate that eventually all high-



priced and intensively cultivated crops throughout the humid region will be insured against drought by supplemental irrigation.

#### DRAINAGE INVESTIGATIONS.

The drainage investigations of the Department of Agriculture are destined to play no mean part in the development and conservation of our natural resources. There are in the United States approximately 79,000,000 acres of land, exclusive of tidal marshes, that can not be profitably cultivated on account of excess moisture. It has been estimated that this area, comprising 52,665,000 acres continually wet, 6,826,000 acres of wet grazing land, 14,748,000 acres periodically overflowed, and 4,766,000 acres of farm land periodically swampy, could be drained at a net profit of \$1,594,000,000, measured by increased land values, with an increase of annual income estimated at \$273,000,000. Western irrigated lands that but recently yielded grain and fruit abundantly have been abandoned, having become swampy or incrustated with alkali. The area affected, already great, is enlarging every year as irrigation continues. The lack of natural drainage is requiring that artificial means be provided for removing the excess water and preventing a large part of the lands under irrigation from being rendered worthless.

#### SCOPE.

Previous to 1902 the department gave no special attention to land drainage. Now the investigations embrace a study of the requirements of drainage in various localities and under differing conditions; the collection of technical data of service to engineers and others having to do with the design of drainage improvements; and the rendering of assistance by correspondence to owners of land needing drainage, by personal consultation and occasionally by surveys with reports presenting detailed plans for the requisite improvements. The construction work, however, is done by the land-owners to be benefited. Investigations have been conducted in nearly every State. The total area surveyed is approximately 8,800,000 acres, classified as follows: Subject to periodical overflow, 4,110,000 acres; continually wet, 3,550,000 acres; requiring new or improved outlet channels, 760,000 acres; farm lands needing complete drainage, 20,000 acres; irrigated lands, 360,000 acres.

#### RESULTS.

As the result of the department's work there has developed a very active interest in the drainage of the swamps and other wet lands of the coastal plain, from Maryland to Texas. Drainage engineers of the Office of Experiment Stations have examined a large part of those areas, preparing plans for more than half a million acres.

Tracts of the fertile wet prairie lands of the Louisiana gulf coast are being surrounded by embankments and drained by means of pumps. This development will ultimately involve problems equal to those of reclaiming the lowlands in England and Holland.

Communities embracing large overflowed areas in the Missouri and Mississippi Valleys are organizing and constructing drainage improvements. The levees along the lower Mississippi River have in some measure complicated the drainage problems there, as they make it necessary to divert waters from their natural channels and discharge them at considerable distances farther down the valley. No little judgment is required to devise drainage systems that will be economical and efficient, at the same time subdividing the natural drainage units into such parts that the necessary cooperation of the landowners can be secured to complete the work of reclamation.

#### SEEPAGE AND ALKALI.

The injury to irrigated lands from seepage and alkali has undoubtedly been hastened in many instances by the unnecessarily lavish use of water, but except where soil conditions are unusual, the same effects, in a modified degree, will follow sooner or later even with the greatest economy of irrigation. Not all the water applied can be retained in the root zone of the plants; the balance percolates downward until checked by some impervious stratum, accumulating until the plane of saturation is raised sufficiently to render the ground surface swampy in the lower places.

Injurious salts in solution may be carried to the surface by capillarity, and there deposited as the water is evaporated, even when the ground is not saturated to the surface. The investigations have determined that while methods of drainage used in the humid sections are often valueless in the irrigation region, seeped lands can be reclaimed by drains properly designed and installed. The drains are usually laid at considerable depth to intercept the underflow from higher lands. Relief wells may be below the drains to offer the water an easy passage upward from a loose underlying stratum, rather than above the drain to admit surface water. Each irrigated tract requires a study of subsurface soil and water conditions, such as is not considered in drainage east of the one-hundredth meridian.

#### COLLECTION OF TECHNICAL DATA.

The collection of technical data is an important part of the drainage investigations. This includes determining the quantity of water to be removed and how it is affected by rainfall, topography, soil, vegetation, and size of watershed area; the capacity of drainage channels under various conditions of smoothness and of uniformity of cross section; the special requirements for draining muck and peat soils;

the conservation of soil on hillsides; and the proper depth, spacing, and arrangement of open ditches and tile drains for the various kinds of soils. In the irrigated region special study is made of the movement of ground water and of the effectiveness of drainage in removing alkali. While definite quantitative results in some of these lines must wait upon further investigations, the data already obtained have enabled invaluable advice to be given with respect to particular projects.

### **LIBRARY.**

#### **LARGEST COLLECTION OF AGRICULTURAL LITERATURE.**

The growth of the library during the past 16 years has more than equaled its growth during the previous 34 years of its existence. In 1897 it contained approximately 59,000 books and pamphlets, while to-day its collections number 122,000 books and pamphlets. The library at the present time contains the largest collection of literature in this country on agriculture and related sciences, and as far as known is the largest agricultural library in any country.

In the subject of American agriculture, including horticulture, forestry, pomology, dairying, live stock, poultry, agricultural statistics, and the various agricultural crops, it is especially complete. In addition, it has a large and representative collection of the most important foreign agricultural books and periodicals and a collection of the publications of foreign agricultural institutions, societies, and experiment stations, which is without question the largest and most complete in the United States. In the sciences that relate to agriculture, such as botany, chemistry, and zoology, the library's resources compare favorably with the resources of the large college and reference libraries of the country in these subjects, and along economic lines are probably unsurpassed.

It is especially strong in scientific and technical periodicals and society publications. Nearly 2,000 periodicals are being received currently, of which number a little less than two-thirds are sent as gifts and exchanges.

#### **CATALOGUES.**

Since 1897 the appropriation for the library has been increased from \$13,960 to \$40,500, and the staff has grown from 6 to 29. There has been a corresponding increase in the activities and usefulness of the library. Only a comparatively small portion of the library was catalogued in 1897; to-day the dictionary card catalogue, containing approximately 286,000 cards, includes entries for nearly all the books in the library and is an invaluable key to the literature of agriculture and the related sciences. In 1899 the issuance of a card catalogue of the publications of the department was begun by the

library. It was, as far as known, the first attempt on the part of any institution to furnish to the outside world a complete printed card catalogue of its publications. The service in printed cards was still further increased in 1902, when the printing by the Library of Congress of the catalogue cards for accessions to this library was begun, the library of the department being the first of the department libraries to cooperate in this way with the Library of Congress.

In addition to issuing these printed cards, the library has made its resources better known by printing separate catalogues of publications relating to botany, forestry, irrigation, and entomology, and lists of its periodicals. It has also published regularly a bulletin of its accessions.

In 1897 the library occupied the large room on the second floor of the main building into which it had been moved 10 years previously, and it continued to occupy this room until 1908, when, on the completion of the new laboratory buildings, it was moved to the ground floor of the east wing. The rooms being designed for laboratories are not well fitted for library use, but it is a matter for congratulation that the library is now stored in a fireproof building, as it would mean an almost irreparable loss to the department if the library's collections were destroyed.

#### INCREASING USE OF LIBRARY.

With the growth of the department in the past 16 years the use of the library has increased more than 500 per cent. Its usefulness to the State agricultural colleges and experiment stations has also been greatly extended. Whereas only an occasional book was formerly borrowed by an agricultural college or experiment-station worker, during the past year 620 books were lent to workers in 39 different States and Territories, in range from Maine to Hawaii and from Oregon to Florida and Porto Rico. By increasing and perfecting the library's collections, in order that it may more fully meet the demands made upon it and by making its collections and services widely useful, the library is from year to year performing more and more the duties of a national library of agriculture.

#### FOREST SERVICE.

##### PREVIOUS ORGANIZED ACTION.

Forestry in the United States at the beginning of 1897 was still in its dark ages. Its general practice seemed about as imminent as when Columbus first set foot upon the shores of a new world. A few far-sighted and public-spirited men had tried from time to time to arouse realization of the danger that lay ahead if wasteful destruction of a great primary resource were not checked; but they

were as voices crying in the wilderness. Their warnings were, on the whole, rather less productive of results than had been similar warnings in colonial days.

Unquestionably one reason why predictions of direful consequences in store if waste were not curtailed aroused little interest was the fact that the cry of "wolf" was so old. The history not merely of agitation but of legislation with regard to forests reaches back into the early days of settlement along the Atlantic coast. Laws for the care and protection of forests were placed upon the statute books of several of the Colonies.

Late in the eighteenth and early in the nineteenth century agricultural societies in Massachusetts and New York acted on behalf of forest protection and promotion of the growth of forests. Between 1799 and 1831 Congress legislated again and again with a view to insuring the maintenance of supplies of live oak. In 1867 horticultural and agricultural societies in Wisconsin appointed a committee to report on the results of forest destruction. Laws for the encouragement of tree planting were passed between 1868 and 1874 in nine Western and two Eastern States. In 1869 the board of agriculture of the State of Maine took action toward the formulation of a forest policy. Arbor Day was instituted in 1872. In 1873 Congress passed the first timber-culture act. The American Association for the Advancement of Science appointed in the same year a committee to memorialize Congress and State legislatures upon the importance of promoting the cultivation of timber and the preservation of forests. The American Forestry Association was founded in 1872 and the Pennsylvania Forestry Association in 1876. The latter year marked the inauguration of forest work by the Department of Agriculture.

These are scattered examples of organized action to meet either a recognized or a supposed danger. That forest destruction was proceeding apace and threatened serious consequences had been the declaration of some observers from early days down. Those who govern their course by rule of thumb instead of by a careful analysis of conditions, and therefore hold that only what has happened will happen, were inclined to be more than skeptical concerning the existence of this particular wolf. The alarm had been raised too often. Cassandra prophecies of the approach of a timber shortage were generally received with tolerant incredulity when they did not call forth outspoken contempt.

#### FEAR OF WOOD FAMINE IS RECENT.

The opinion was still commonly advanced that the forests of the country were inexhaustible. Practical men who had had sufficient opportunities of observation to know the contrary were content in

the thought that the supply would last their time. Such an attitude was the more readily justified by the fact that no matter what convictions were held on the subject there appeared to be nothing in particular that anybody could do about it. Economic conditions were thought not ripe for a change. Wasteful exploitation must run its course, it was argued, and a great national asset continue to vanish in smoke until the price of protection became worth while and until the market value of a tree made growing it good business.

It may fairly be said that half a generation ago the fear of a wood famine was a matter that had not entered the field of vision of the average man. Some sagacious ones, it is true, were giving practical but unostentatious evidence of their capacity to see ahead by gathering into their ownership all the cheap timberlands that they could acquire. Thus were laid the foundations of great fortunes. Timber reservations by no means began with the Government. The proceeds of lumbering in the virgin forests of the Northeast and in the matchless Lake State pineries, once Government owned, were often re-invested in southern yellow-pine lands or in the cream of western timber. This, however, was foresight exercised for private ends. Those who put their money into such investments counted—and with reason—on diminishing supplies to force up the value of their holdings. But those who urged the necessity of public action to provide for future public needs were thought to be disturbing themselves unduly in matters which were proper subjects for the attention of Providence rather than of men. To concern oneself overmuch lest wasteful use of the resources placed at human disposal might leave posterity with nothing to use argued a lack of confidence in the Divine wisdom which had put us in a world designed for the satisfaction of all essential needs. If the forests should ever fail, there would be something better to take their place.

This optimistic point of view was fostered by the very circumstances which in reality gave greatest cause for apprehension. Unexpected and momentous changes had revolutionized the conditions on which had been predicated the early forecasts of approaching need. While by falsifying these forecasts they had operated to lull the public mind into a feeling of unjustified security, they had actually created a situation a hundredfold more serious than before. In the eighteenth and early nineteenth centuries the question of forest supplies was purely local. Transportation except by water for any great distance was out of the question for so bulky a commodity.

#### AWAKENING TO THE PROBLEM.

With the development of railroads affairs took on a wholly new aspect. Continental supplies were substituted for local. In the mid century the forests about the Great Lakes began to melt away,

going east, west, and south, to rise again in the countless homes of an expanding nation. From open prairie to seaboard cities, from the factory towns and hamlets of New England to the growing commercial centers and the multiplying crossroad villages of the Middle West, they fed prosperity, and fireswept desolation blotted the land of their origin.

Thus was created a problem which is now not nation wide, but world-wide. New York bids against South America and the Orient for the timber of the Pacific Northwest. Southern pine goes by water from the Gulf to Great Britain or the North Atlantic States; by rail, to meet the output of Montana's forests on the plains. In 1911 the United States exported domestic forest products to a total value of over \$100,000,000, of which Europe took over \$55,000,000 worth and South America about \$25,000,000 worth. All the countries of eastern Europe must import timber to meet the excess of their needs over the home supply. Meanwhile, with an estimated home consumption of 23 billion cubic feet of wood annually, our depleted and abused forests are producing by growth probably less than 7 billion feet. The Bureau of Corporations of the Department of Commerce and Labor estimates the existing supply of saw timber in the United States at less than 3,000 billion board feet, which is equivalent to about 500 billion cubic feet. Economists now recognize that, taking the world over, wood consumption exceeds its growth, and that a crisis approaches.

That some measure of public provision has been made for maintained supplies of a great public necessity; that we are not merely 16 years nearer the time when wood shortage will handicap building, mining, and manufacturing, the railroad, the merchant, the farmer, the wage earner, and the consumer; that one-fifth of the standing timber in the United States is not only held and protected in national forests, but also open to use under methods which will mean increasing production through growth and successive harvests for all time; that the public is fully awake to the importance of preventing forest fires everywhere, and of substituting forest management for forest exploitation; that private owners recognize in forestry not an impracticable counsel of perfection and a fad of theorists but a tangible business proposal; that lumbermen show a growing realization of the fact that their industry is one affected with a public interest, and therefore involving a public responsibility; that immense gains have been made in reduction of waste and increased length and amount of service obtainable from what is cut; that conservation of natural resources has become an accepted public policy and a clearly perceived matter of national welfare—all these are results primarily and directly due to the work of this department within the last 16 years.

Solely to that work is due the fact not only that the great bulk of the national forests were ever set aside, but also that the justifiable demand for the supply of immediate needs has not been confronted by a flat taboo upon use which would have meant the abandonment of reservations already made. Solely to that work, again, is due the fact that the practice of technical forestry in the United States has been made possible by the gathering through the years of the basic scientific knowledge on which alone good practice can be founded. Had this great work not come when it did, most of our remaining publicly owned forests would have passed forever from public possession and private monopoly would now be forging its fetters with no prospect of relief save by the slow and difficult procedure of legislation in the face of vested rights. In 1905 I wrote:

Seven years ago there were in the whole United States less than 10 professional foresters. Neither a science nor a literature of American forestry was in existence, nor could an education in the subject be obtained in this country. Systematic forestry was in operation on the estate of a single owner, honorably desirous of furnishing an object lesson in an unknown field. Lumbermen and forest owners were skeptical of the success of forest management, and largely hostile to its introduction. Among the public at large a feeling in favor of forest preservation, largely on sentimental grounds, was fairly widespread, but almost wholly misinformed. It confounded use with destruction, shade-tree planting with forestry.

The real need of forestry was urgent. A time had come which presented at once a great opportunity and a dangerous crisis. Forest destruction had reached a point where sagacious men—most of all, sagacious lumbermen—could plainly discern the not distant end. The lumber industry, vital to the Nation at large, was rushing to its own extinction, yet with no avenue of escape apparent until forest management for future crops should be forced by famine prices. Meanwhile, however, the ruin would have been wrought already.

Timberland owners were selling their holdings or their stumpage with little evidence of an understanding of their future values, and lumbermen were compelled by business competition to keep down the cost of operation to the lowest terms or market their product at a loss. Forestry was both an evident economic need and an apparent economic impossibility. Few well-informed persons believed that the obstacles to its introduction could be overcome sufficiently to bring it into common practice among private owners during the lives of the present generation. That the whole situation is profoundly altered is directly and chiefly due to the work of the Forest Service.

Forestry is a matter of immediate interest to every household in the land. Forest destruction is no imaginary danger of a distant future. If it is not speedily checked, its effect will sooner or later be felt in every industry and every home. To make these facts known is a national duty. The work of education must continue until public opinion will not tolerate heedless waste or injudicious laws.

These words are no less true now than when they were written, except for the fact that the record of progress has been materially enlarged. In retrospect one central fact stands out—that the key to the whole situation was seized when the practice of forest conservation was shown to involve not the rearing of blind barriers



against the utilization of resources, but the development of resources through wisely regulated use. For passive prohibitions were substituted constructive activities.

#### USE OF NATIONAL FOREST RESOURCES.

The era of mere reservation culminated when President Cleveland, at the close of his administration, more than doubled in a day the total area covered by withdrawals under the act of March 3, 1891. That act empowered the President to set apart "public lands wholly or in part covered with timber or undergrowth, whether of commercial value or not, as public reservations." With the Cleveland additions the forest reserves totaled, on the 4th of March, 1897, not quite 40,000,000 acres.

For use of these forests no provision whatever had been made. The land was theoretically closed to all human occupation or enjoyment. In consequence an outburst of indignant protest from the West demanded that the newly created reserves should be restored to the public domain. Instead, the proclamations were suspended for a year and the act of June 4, 1897, passed. By authorizing regulated use of all national forest resources this act laid one of the two main foundations on which rests the present system of administering the forests. The second and no less necessary foundation was provided by the work inaugurated in this department one year later.

#### LACK OF KNOWLEDGE IN 1897.

It is difficult to realize in 1912 how completely lacking in 1897 was the knowledge necessary for the application of forestry in the United States. Almost no field studies of consequence had ever been made. The Division of Forestry, as it existed in my department when I took office, employed all told 13 persons, of whom 5 were clerks and 1 a messenger. It was a bureau of information and advice merely. It had no field equipment. It was supported by an annual appropriation of \$28,520. How its work was regarded may be judged by the fact that Congress, in making this appropriation for the year 1899, attached a provision that the Secretary of Agriculture should make at the beginning of the following session a special and detailed report "upon the forestry investigations and work of the Department of Agriculture, showing the results obtained and the practical utility of the investigations."

#### SUBSEQUENT POLICY.

Early in the fiscal year 1913 the Forest Service employed a total of 4,097 persons. Its appropriation for the current year is over \$5,000,000. Its field of work is the entire United States. Its administrative and protective duties alone (including cooperation with

States in the protection from fire of lands on the watersheds of navigable streams) are discharged in 34 States of the Union and in Alaska. The printed results of its investigations are among the publications sold in largest numbers by the superintendent of public documents, while the Department of Agriculture printed for distribution without charge, between July 1, 1897, and June 30, 1912, a total of 12,601,450 copies of Forest Service publications.

In mere size, therefore, as indicated by expenditures, the Division of Forestry of 1897 compares with the Forest Service of 1913 in about the ratio of 1 to 200, and as indicated by personnel in the ratio of 1 to 372. An announcement in the annual report of the division for the fiscal year 1897 formed the point of departure for this great expansion. A radical change in the character of the work planned was then made. This change may be put in a word: The field of activities was shifted from the desk to the woods.

Private owners of woodlands were offered an opportunity to obtain practical advice and assistance looking toward the introduction of forest management on their holdings. The response was immediate, and swiftly swelled. The area for which such advice had been asked by the close of the fiscal year 1898 was nearly 1,000,000 acres; of 1900, nearly 2,500,000 acres; of 1905, nearly 11,000,000 acres. Examinations actually made had, in 1905, covered about 4,000,000 acres. Eight years of work had fairly launched the forest movement.

The offer of advice to forest owners had for its ends investigation, demonstration, and education. Forest management is first of all a matter of practice, just as is the management of a farm. Both farmer and forester must base their practice on knowledge, and to that end knowledge must be gathered. Nevertheless, the final object is not to learn, but to do. In order to advise and assist owners who were contemplating forest management, the Division of Forestry had first to create a body of knowledge on which to base both plans of procedure having definite objects in view and estimates of the yield which might be expected under these plans; and, further, it had to devise practicable methods for carrying out these plans and to calculate what carrying them out would cost. In other words, it had to create a science, develop a technique, and work out business conclusions all at once. It succeeded because the fact was firmly grasped that the forester must not be primarily a scientist, but a director of operations. As capacity along this line was developed it was proposed to demonstrate to individual private owners how to make forestry pay, and thus to secure educational examples which other owners might follow.

As it proved, the greatest result gained was the gathering and training of a corps of technical foresters qualified by the character of their

experience to assume charge of the management of the national forests. The date on which, early in 1905, administrative jurisdiction over the forests was transferred to me divides the 16 years, 1897-1913, into two eight-year periods, of which the first was that predominantly of investigations, preparation, and public education, and the second predominantly of administrative activities. Yet entirely apart from the fact that the work of the earlier period made public forestry possible in the United States, it yielded results of enormous value in actual improvement of lumbering methods and widespread introduction of forest protection.

At the close of the nineteenth century lumbermen everywhere in the United States were operating with a disregard of waste inherited from days of more abundant supplies and lower prices. Stumps were cut high, marketable saw timber was left in tops, and merchantable logs were left in the woods. Further, the value of young growth not yet merchantable and the money sacrifice involved in cutting small-sized timber which, if left for a later cutting, would make rapid increase in size and value, were almost unrecognized. The first fruits of cooperation between the foresters of this department and private owners who sought their advice were accurate computations of what was to all intents and purposes money thrown away, that startled into instant attention practical woodsmen who had previously considered themselves abundantly familiar with their own business. The mere saving of unnecessary waste in lumbering was, indeed, not forestry; but the demonstration that it afforded a neglected opportunity for profit was both a material gain for forest conservation and an open sesame for the forester standing without the door of a great established industry whose practices he sought to revolutionize.

From the north woods of New York and New England to Texas and into the far West swept the new gospel of closer utilization. With or close behind it went the turning of attention to the value of immature timber in the present stand. Operators began to reckon on returning for a second and even a third cutting. Such a policy involved of necessity consideration of the fire risk. Agitation for organized fire protection by States began. The number of private owners of timberland in large holdings who have entered definitely on the policy of permanent wood production is as yet infinitesimal, but the number of those who have adopted some substitute for the old policy of immediate devastation and indifference to what may follow is very large. This in itself is a result of the utmost importance from the standpoint of the public welfare. To it the work of the division and later the Bureau of Forestry, now become the Forest Service, directly led.

Prior to 1897 the only State in which the forest question had received any material recognition was New York, which had estab-

lished State reservations in the Adirondack and Catskill Mountains and had inaugurated a system of fire protection for them, but along lines incapable of yielding effective results. In May, 1897, Pennsylvania enacted the law under which a policy of forest reservations was inaugurated for that State. Unlike New York, Pennsylvania did not adopt restrictions which closed these reservations against any actual practice of forestry upon them, but it had neither field work nor field force. There was no professional forester in the employ of any State in the Union. There are now 20 such State foresters. Thirty-three States have enacted laws shaped in the light of the knowledge made available by the work of the Department of Agriculture. Thirty-one States have sought and received the assistance of the department in the study of their forest problems. The entire movement for State forestry is the outgrowth of the work done by this department in the last 16 years, with the single exception of the movement in the State of Pennsylvania; and even there, though independently and ably led, most of the progress made could hardly have come about had there been no national movement to help it along.

Hand in hand with the creation of the science and development of the practice of American forestry, the awakening of the country at large to the issues involved and the crystallizing of sentiment into definitely formulated public policy, went the promotion of more economical use of the material drawn from our forests. To make what we have go further was equivalent to an augmentation of the supply. Study of the whole problem of utilization was pressed into varied fields.

#### PRESERVATIVE TREATMENT OF WOOD.

The preservative treatment of wood against decay was in 1897 practically unknown in the United States. Investigations to show what would be the money gain to the railroads through lowered costs of maintenance if ties were treated to prolong their life, and what form of treatment would prove most advantageous, were begun in 1903. To-day one-fourth of the ties used in the United States are given treatment and the number treated increases yearly, while another large fraction gain greater durability through recognition of the value of proper seasoning, as developed by our investigations. Methods of preservative treatment suitable for the use of farmers, whose fence post needs create in the aggregate an immense demand for material, have been devised. Telephone and telegraph companies are beginning to treat their poles and mine operators their timbers. This is but a single example of the way in which economies have been made possible. One or two others may be briefly mentioned; but an exhaustive list even of the leading achievements in this general field can not be entered upon here.

## TURPENTINE.

In 1902 a method was devised whereby it has become possible to secure a materially larger yield and better quality of crude turpentine, with indefinite prolongation of the formerly brief period of years during which the crude material of the naval-stores industry could be gathered from the same trees. Commercial operations on the Florida National Forest have demonstrated that the naval-stores industry may be perpetuated, instead of being destroyed through the wasteful methods which have removed the industry from the Carolinas where it started. At the same time a vast new field of future naval supplies has been indicated through experiments conducted on national forests in Arizona, California, and Colorado, which have shown that western yellow pine may be utilized to supplement the pine forests of the Southeast as producers of turpentine and rosin.

## STRENGTH OF TIMBERS.

Another great gain has been made through better knowledge of the strength of the various kinds of timbers used in construction and of the physical properties which determine the use to which woods may be put. While some strength tests of timbers had been made prior to 1897, the results had little applicability to construction work. Since 1902 systematic and exhaustive study of this subject has been under way, covering practically all native species of commercial importance. Tests on the woods themselves and upon wood products have led to utilization of various species formerly disregarded and to large economies in consumption.

## NEW WOODS FOR PULP.

From 1897 to 1913 the consumption of wood for pulp quadrupled. At the beginning of this period three-fourths of all the pulp was spruce, and less than one-fourth of it was imported. Now, with an annual consumption of about 5,000,000,000 cords, 40 per cent is spruce, and about half is imported. In this period the price of spruce doubled. Exports of wood pulp have fallen off and imports have increased fourfold. These figures point to the fact that if the United States is to furnish its own supply of wood pulp it must do so from substitutes for spruce. Tests made by the department show that pulps of commercial value suitable for news and wrapping paper can be made by the sulphite process from eight native woods, several of which grow in quantity on the national forests. Some of these woods are beginning to be used to a limited extent. The department's activities also have proved that native species, large quantities of which are available and cheap in the Lake States, can be substituted for spruce in the ground-wood process for news print

paper. As a direct result of these experiments several mills have begun grinding these woods. Moreover, the department has demonstrated in its paper laboratories, which work under conditions comparable with those of practical manufacturing plants, that efficiency in pulp making can be raised far beyond that which obtains in the ordinary plant.

#### WOOD DISTILLATION.

In wood distillation the department has demonstrated that commercial yields of acetate of lime and wood alcohol can be obtained from various new woods and from mill waste of these woods. It has also demonstrated that a yield of acetate of lime more than one-half greater than the present can be obtained. There is now being installed in the forest-products laboratory a still of special design, contrived by our investigators for the production of ethyl alcohol from wood waste. Only the methyl or wood alcohols are now so produced. There is wasted in the United States each year 6,000,000 tons of slabs, edgings, and sawdust, each ton of which is capable of yielding 15 gallons of alcohol, if the proper commercial process can be developed.

#### KILN-DRYING.

In the artificial seasoning, or kiln-drying, of lumber, lack of scientific knowledge of what is involved and of accurate control of the methods used has been a cause of heavy loss. The average amount of material rendered unfit for use in kiln-drying is 3 per cent for softwoods and 10 per cent for hardwoods, which means a money loss of millions of dollars annually. After years of study the department has arrived at such a knowledge of the theory and practice of drying lumber as makes possible a dry kiln in which temperature, circulation, and humidity of the air are under control of the operator. This solves the fundamental problem.

#### FOREST RESOURCES.

When the twentieth century opened the actual situation with regard to forest supplies was a matter of entire uncertainty. The census had published figures of lumber production at successive 10-year intervals, but there was no knowledge of what supplies the country possessed or of the rate at which those supplies were replenished by growth. In 1907 the Forest Service brought together from all existing sources of information its first estimate of our actual forest resources. This stock taking was carried further in the reports prepared for the Conservation Commission. These figures, combined with the figures of annual consumption, collection of which began in 1905, showed for the first time to all the danger of an impending timber shortage.

## FOREST PRODUCTS LABORATORY.

The major part of the investigative work to promote better use of what our forests furnish is now conducted at the forest-products laboratory which has been developed at Madison, Wis. The facilities for scientific research provided by this laboratory are unexcelled in any country, and the building up of this instrument of research is in itself an achievement of no mean importance. Results are being attained which mean a lessened drain upon our forest supplies through more economical use of material, the opening of new sources of supply for various industries, the utilization of every kind of wood for the purpose to which its intrinsic qualities best adapt it, a greater incentive to the practice of forestry because of the increased returns made possible, better adjustment of wood-using industries to meet the conditions created by past use without forethought, and a general clarifying of the situation with respect to our forest resources and requirements through accurate knowledge of what these requirements are and what is available to fill them.

## PROBLEMS OF MANAGEMENT.

But by far the greatest achievement of the 16 years in forestry has been the working out of the national forest policy provided for by the act of June 4, 1897. This achievement is, indeed, one of the notable events in the recent history of the country. It may fairly be expected to remain an enduring milestone of progress and a matter of permanent importance. Without mention of it, no future account of the first decade of the twentieth century will be complete.

The act of June 4, 1897, conferred upon the Secretary of the Interior every authority and power necessary for managing the national forests in accordance with the principles of practical forestry. Funds for this purpose were first made available for the fiscal year 1899. An administrative force, consisting of superintendents, supervisors, and rangers, was thereupon organized. It shortly became apparent, however, that the task of opening the forests to wise use and of developing their resources effectively was one for which the department then in charge was not well equipped. Accomplishment of this task demanded not only authority in law but also technical knowledge constructively applied. In so far as there existed at that time any technical knowledge at all of the principles of forest management, it was in the small but energetically working and rapidly growing Division of Forestry in this department. The result was that on December 7, 1899, the Secretary of the Interior made a request upon me for technical advice regarding the management of the forests.

During the next five years such advice was given, to the extent of the resources available. Field parties were sent out to study the forest conditions and gather the data necessary for the preparation of plans of management. The fundamental problem was to know how use might be so regulated as to insure perpetuation and even improvement of the resources concerned, along with the largest immediate returns consistent with permanence. There were recognized three major resources to be both used and safeguarded—timber, water, and range.

The most immediately urgent part of the problem was, on the whole, that relating to the range. Because of the harm done both to forest growth and to water flows by overgrazing, all these resources were to some extent at stake; grazing could not be dealt with as a matter of forage production solely. From the nature of the range-stock industry and because of the general economic conditions which existed throughout most of the West, it had come about that while the demand for national-forest timber was exceedingly restricted and almost entirely local, the forage crop was almost everywhere in great demand. Sheep and cattle competed with each other for the summer feed found in the forest-clad mountains, and rival sheepmen and cattlemen competed among themselves. Much of the range had become so overcrowded as to cause serious impairment of its carrying capacity, and the evil was thus accentuated. Progressive deterioration threatened to wipe out both the forage resource and most of the stock industry dependent upon it. Hand in hand with range depletion went damage to water supplies, inflicting hardships upon settlers in the valleys and imperiling the welfare of great regions. Forest growths also were seriously affected. The belief was common that conditions required the exclusion of all sheep from many, at least, of the National Forests.

In the first year or two of administrative control, however, a policy of regulation was entered upon. Largely as a result of the expert advice given by scientifically trained men of this department, the beginnings of systematic grazing control were developed. It was obvious that only specialized knowledge of range vegetation and of grazing methods could constitute a basis for devising such an adjustment of use to existing conditions as would serve to restore the carrying power of the range without undue disturbance of the established stock industry. Experience soon proved that mere assistance in devising an administrative policy was not adequate to meet the needs of the situation. Expert knowledge was needed also in carrying the policy into effect. It was perception of this fact which led the Commissioner of the General Land Office and the Secretary of the Interior to urge the transfer of the National Forests to the Depart-



ment of Agriculture. In his annual report for 1903 the Commissioner of the General Land Office said:

The work of establishing a forest service for the care and administration of the reserves \* \* \* has been developed along such practical lines as fall within the province of the Interior Department. The experience of these five years abundantly testifies to the need for efficient work of a scientific character. The dangers to which the reserves are exposed from fires, timber depletions, and other sources make the establishment of an efficient protective force a matter of great importance. Following closely upon that, however, must come the application of scientific methods in dealing with the many and various forest problems in connection with the various industries affected thereby. \* \* \* Elementary efforts need to give way in the course of development of such a system. It would seem, therefore, that the point has been reached when the work should be committed to the care of men who have had the scientific and practical training needed to cope with work involving such far-reaching issues. The Bureau of Forestry of the Department of Agriculture is properly organized and equipped to carry on this branch of the work.

Recommendations to the same effect were repeated the following year. An act of Congress, which became law on February 1, 1905, effected the transfer.

#### STATISTICS OF USE OF THE NATIONAL FORESTS.

The salient fact disclosed by the statistics of use of the forests since that time is the immense acceleration effected by the transfer in the rate at which the resources were made available. In 1905 there were issued not quite 8,000 grazing permits; in 1912, over 26,000. The 1905 permits were for approximately 600,000 cattle as against 1,400,000 in 1912, 60,000 horses as against 95,000, and less than 1,800,000 sheep as against nearly 7,500,000. In 1905 the number of timber sales made was about 400; in 1912, nearly 5,800. The 1905 sales covered about 100,000,000 board feet, while those of 1912 covered 800,000,000 board feet; and the receipts from timber sales rose from less than \$86,000 in 1905 to over \$1,000,000 in 1912. In 1905 not quite 3,400 free-use permits were issued; in 1912, nearly 40,000. These permittees in 1905 took from the forests free of charge the equivalent of about 27,000,000 board feet; in 1912, over 123,000,000. In 1905 less than 300 applications for special-use permits were granted; in 1912, nearly 5,000. It is true that in comparing these figures allowance must be made for the fact that on June 30, 1905, the total area of the National Forests was less than 86,000,000 acres as against over 185,000,000 acres on June 30, 1912; but with all allowances made the evidence remains impressive and overwhelming. The application of technical management is the master key that is everywhere unlocking the old-time reserves to the public, developing their resources, and demonstrating the methods by which, under public control, they can be made to contribute most fully to our permanent economic welfare.

Time altogether fails in which to set forth even cursorily what has been done on the National Forests. From long before the transfer

the principal source of information concerning the lands suitable for inclusion in forests by presidential proclamation was the Bureau of Forestry. In gathering that information the foresters of the department raced against a swarm of timber cruisers in private employ. A corps of efficient public servants has been built up. Business methods serving the convenience of users have been worked out. A protective system of high efficiency now makes the forests as nearly safe against fire as the too small force and too meager development of means of communication and transportation permit. All in all, as a great constructive accomplishment the National Forests and the administrative system under which they are made to serve their rightful part in our national economy deserve to rank, and will rank, among the notable triumphs of this generation.

#### ADMINISTRATIVE BOARDS.

##### THE REFEREE BOARD.

On February 20, 1908, the Secretary of Agriculture appointed Dr. Ira Remsen, president of Johns Hopkins University; Dr. Russell H. Chittenden, dean of the Sheffield Scientific School, Yale University; Dr. John H. Long, of Northwestern University; Dr. Alonzo Taylor, at that time of the University of California, but now of the University of Pennsylvania; and Dr. Christian A. Herter, of Columbia University, as consulting scientific experts of the Department of Agriculture, and four days later organized them into what is known as the Referee Board. Dr. Herter has since died, and he has been succeeded by Dr. Theobald Smith, of Harvard University.

This board was appointed because a number of large manufacturers of articles of food requested President Roosevelt to select a number of disinterested, scientific men competent to pass upon the question as to whether sulphur dioxide, saccharin, and benzoate of soda are harmful when used in foods. These manufacturers assured the President that they would discontinue the use of these substances in food if such a board found them to be harmful. President Roosevelt corresponded with the presidents of some of the leading universities in the country as to what men were best qualified to make the necessary investigations as to the substances that were harmful or injurious to health when used in foods, and personally selected the five men who were appointed members of the board.

It is the duty of the board to consider and report to the Secretary of Agriculture the wholesomeness or deleterious character of such foods or such articles used in foods as may be referred to them by the Secretary of Agriculture.

The committee of the House of Representatives which considered the pure-food bill subsequently enacted into law apparently

contemplated the employment of eminent scientists to advise the Secretary as to the harmfulness of substances in foods, because the view was expressed in the deliberations of the committee that the Secretary should be allowed a free hand in selecting experts on questions of the wholesomeness of certain foods and the articles used therein. Congress, in the Agricultural appropriation bill, evidently indorsed this view, for this bill contained a provision authorizing the Secretary of Agriculture to employ such assistants as he might consider necessary to secure the enforcement of the law. In his opinion of April 14, 1909 (27 Opinions, 301), the Attorney General held the appointment of the members and the organization of these members into a board to be legal.

There may be questions arising in the administration of the food and drugs act on which the Secretary of Agriculture may desire an opinion independent of that expressed by the Bureau of Chemistry, as is the case when a great number of food manufacturers of the country claim that the opinion of the Bureau of Chemistry is at variance with the scientific knowledge of the present day.

The questions as to the harmfulness of the use in foods of the following substances were referred to the referee board: Benzoate of soda, saccharin, sulphur dioxid, alum, and sulphate of copper. The board has reported on three of these questions—that is, on the use of benzoate of soda, saccharin, and sulphate of copper—and the other questions are still pending before it. In arriving at conclusions on questions submitted to them the board must make original investigations, and on the questions determined independent original investigations were made by several members of the board.

#### BOARD OF FOOD AND DRUG INSPECTION.

In 1907 a Board of Food and Drug Inspection was organized in the Department of Agriculture to assist the Secretary of Agriculture in the administrative work connected with the enforcement of the food and drugs act of June 30, 1906. The duties of this board as defined in General Order No. 111 creating it are as follows:

\* \* \* The board will consider all questions arising in the enforcement of the food and drugs act of June 30, 1906, upon which the decision of the Secretary of Agriculture is necessary, and will report its findings to the Secretary for his consideration and decision. All correspondence involving interpretations of the law and questions arising under the law not theretofore passed upon by the Secretary of Agriculture shall be considered by the board. The board is directed to hold frequent meetings at stated times, in order that findings may be reported promptly.

In addition to the above duties, the Board of Food and Drug Inspection shall conduct all hearings based upon alleged violations of the food and drugs act of June 30, 1906, as provided by regulation 5 of the Rules and Regulations for the Enforcement of the Food and Drugs Act, approved October 17, 1906.

This board has conducted a large number of hearings on cases of alleged violations of the law and has considered all cases reported by the Chief of the Bureau of Chemistry as being in violation of the law. In addition the board has conducted an extensive correspondence relating to the application of the law to various products and the complex questions arising in the interpretation of the law.

From time to time the board, with the approval of the Secretary of Agriculture, issues decisions defining the attitude of the department on questions relating to the application of the law to the food and drug industries. These decisions serve as a guide to the officials in charge of the enforcement of the law and acquaint the manufacturers, jobbers, and dealers with the attitude of the department in these matters.

#### SOME OF THE IMPORTANT DECISIONS.

Among the important decisions so far issued, in addition to those decisions merely explaining in greater detail and amplifying the regulations, may be mentioned the following:

(1) Prohibiting the use of coating of any kind on rice if the product "be mixed, colored, powdered, coated, or stained in a manner whereby damage or inferiority is concealed," and providing in any case that rice when coated in any manner should be labeled with the name of the extraneous substances used. (2) Restricting the use of coloring matter in food products to certain harmless vegetable colors which can only be used after having been tested and approved by the department. (3) Prohibiting the use of all chemical preservatives that are known to be harmful, and requiring that when any preservatives are used the fact of their use must be stated on the label. (4) Prohibiting the bleaching of flour with nitrogen peroxid. (5) Prohibiting the use of shellac and other gums for coating chocolates and other confections. (6) Restricting the sale of canned goods which contain salts of tin derived from the solvent action of the contents of the package upon the tin coating. (7) Prohibiting the shipment in interstate commerce of green, immature citrus fruits which have been artificially colored by holding in a warm, moist atmosphere for a short period of time after removal from the tree. (8) Prohibiting the use of saccharin and copper sulphate in foods. (9) Prohibiting the importation of and interstate commerce in absinth.

These are only a few illustrations showing the nature of the decisions of the board. The decisions are published when issued and are distributed to the trade or any interested parties.

#### INSECTICIDE AND FUNGICIDE BOARD.

Responding to a growing demand by agricultural interests and manufacturers for Federal control of interstate commerce in insecticides, Paris green, lead arsenates, and fungicides, Congress passed a

law, which was approved April 26, 1910, known as the insecticide act of 1910. The duty of collecting and examining official samples of articles coming within the meaning of the law and of certifying violations thereunder to the Department of Justice for prosecution was reposed in the Department of Agriculture, and for the performance of this duty a board of four scientists selected from as many bureaus of the department was created to assist the Secretary of Agriculture.

Official samples of insecticides and fungicides which have entered into interstate commerce or have been manufactured or sold within a State are collected by authorized sample collectors of the Department of Agriculture and are transmitted under seal, accompanied by the necessary evidence of interstate movement, to the Insecticide and Fungicide Board. Each sample is carefully analyzed and tested to determine whether it is adulterated or misbranded within the meaning of the law.

The results of examination are then considered by the board, and if the article is found to be in violation of the law recommendation is made to the Secretary of Agriculture through the Solicitor of the department that the responsible parties be cited to a hearing in order that they may have an opportunity to show any failure or error in the findings of the analyst or examiner. Hearings are appointed at such places and are conducted by such officers of the department as may be most convenient for all parties concerned.

Reports of such hearings are forwarded to the board for careful review, and if it still appears that any of the provisions of the law have been violated the facts are certified and all collateral evidence transmitted to the Solicitor, who in turn submits the same to the Secretary of Agriculture for reference to the Attorney General and the proper United States attorney, with recommendation that the offending parties be prosecuted. After judgment of the court, notices of judgment are prepared and given the widest possible publicity.

Various investigations have been made concerning insect powder, Paris green, tobacco powders, Bordeaux mixtures, and other insecticides and fungicides, and half a dozen orders have been issued.

#### FEDERAL HORTICULTURAL BOARD.

Under the act of Congress approved August 20, 1912, a Federal Horticultural Board, consisting of five members drawn from various bureaus of the department, was authorized and the members of the board were soon appointed. The duties of the board are to prevent the importation of nursery stock into the United States except under such circumstances as insure its freedom from plant diseases and insect pests; to prevent the transportation in interstate commerce of

imported nursery stock except under prescribed regulations to prevent the spread of plant diseases and insect pests; to prevent the importation of any plants, fruits, vegetables, roots, bulbs, seeds, and other plant products not included in the term "nursery stock" when such importation would introduce a plant disease or an insect pest.

The Secretary of Agriculture is authorized and directed to quarantine any State or any part thereof when he shall determine the fact that a dangerous new plant disease or insect infestation exists therein.

Among the notices of quarantine already issued by the Federal Horticultural Board is one forbidding the importation of certain varieties of the pine tree from specified European countries; one prohibiting the movement from Hawaii into any other part of the United States of various specified fruits, berries, and seeds; one forbidding the importation of potatoes from certain portions of Europe, the West Indies, and North America; and one prohibiting the movement of Christmas trees, holly, laurel, and other decorative Christmas greens grown in New England from that part of the country to other States.

This quarantine law to prevent the introduction of plant diseases and insect pests was caused by the immense damage that has been done by those that already have been introduced. Among the prominent insect pests that have caused enormous losses to this country are the gipsy moth, the brown-tail moth, the leopard moth, and the elm-leaf beetle, and to these should be added the notorious San Jose scale, the black scale, the white fly of the orange, and the codling moth; and there are the alfalfa weevil, the cotton boll weevil, the cabbage butterfly, and many others.

Among the foreign plant diseases that have been introduced into the United States, prominent ones are the asparagus rust, the cabbage blackleg, European canker of the apple tree, the anthracnose of the grapevine, and to these should be added the crown wart of alfalfa, the rust of clover, the black smut of rice, the blister rust of white pine, and the dreaded blight of the chestnut tree; and there are the rust of the carnation, chrysanthemum, and hollyhock.

#### **EX-OFFICIO FUNCTIONS OF THE SECRETARY OF AGRICULTURE.**

As a part of the work of this department, it is pertinent to mention the ex-officio duties of the Secretary, most of them created within the last 16 years.

The Secretary of Agriculture is designated a member of the board of appeals from decisions of the Commissioner of Internal Revenue as to oleomargarine and substances in imitation of butter, and as to deleterious ingredients in filled cheese.

He is authorized and directed to make rules and regulations, to be approved by the Postmaster General, under which injurious insects may be mailed, transported, etc., interstate.

The Secretary of Agriculture, the Secretary of the Treasury, and the Secretary of Commerce and Labor are to make uniform rules and regulations for carrying out the provisions of the food and drugs act, and to make uniform rules and regulations for carrying out the provisions of the insecticide act of 1910.

A National Forest Reservation Commission was created, consisting of the Secretary of Agriculture, the Secretary of War, the Secretary of the Interior, two members of the Senate, and two members of the House of Representatives, to consider and pass upon lands recommended for purchase for the protection of navigable streams.

An appropriation was made in 1912 to be expended by the Secretary of Agriculture, in cooperation with the Postmaster General, in improving the condition of the roads used in rural delivery and for ascertaining benefits in the operation of the Rural Delivery Service to local inhabitants in transportation of products.

#### OFFICE OF THE SOLICITOR OF THE DEPARTMENT.

##### IMPORTANT AND FAR-REACHING LAWS.

During the 16 years covered by this report there have been a number of important and far-reaching measures enacted by Congress designed for the protection of the health, welfare, and prosperity of the people of the United States. These measures are the culmination of scientific work and investigation of the Department of Agriculture, which exposed conditions requiring legislation to remedy them. Some of the more important acts referred to are the act of February 2, 1903, for the suppression of contagious, infectious, and communicable diseases of live stock; the act of March 3, 1905, which is an enlargement of the above act; the act of May 25, 1900, commonly known as the Lacey Act; the act of June 29, 1906, commonly known as the 28-hour law; the food and drugs act of June 30, 1906; the meat-inspection law of June 30, 1906; the insecticide and fungicide act of April 26, 1910, and the plant quarantine act of August 20, 1912.

All these statutes commit to the Secretary of Agriculture not only the details of their administration, but also the duty of enforcing their penal provisions. Hence it is that the Department of Agriculture has been charged with the execution of some of the most important penal statutes of the United States.

That such should be the case is directly due to the fact that the penal statutes referred to have grown out of conditions which were

exposed by the department in its work to enable it to carry out the purpose of its organization, namely, to diffuse among the people of the United States useful information on subjects connected with agriculture in the most general and comprehensive sense of that word. All these statutes directly bear upon agricultural industries of the people of the United States, and logically their administration has been committed to the Department of Agriculture.

#### SUPPRESSION OF CONTAGIOUS DISEASES OF LIVE STOCK.

The act of May 29, 1884, established a Bureau of Animal Industry in the department, largely for the purpose of advising with State and Territorial officials in regard to the suppression of contagious diseases of live stock. Practically no authority was granted by this act to the Commissioner of Agriculture to regulate interstate commerce in diseased live stock. Sections 6 and 7 of the act prohibited under penalty the shipment and transportation of live stock actually diseased, the penalty, however, to be imposed only in case the animals were known to be diseased at the time they were shipped or transported.

This act did not meet the exigencies of the live-stock industry in the United States, and the department, having found through its investigations that, despite the law, diseases of live stock continued to spread over large areas of the country, recommended to Congress additional legislation to empower the Secretary of Agriculture more effectually to suppress the spread of contagious and infectious diseases of live stock. The recommendations culminated in the passage of the act of February 2, 1903, which authorized the Secretary of Agriculture to establish rules and regulations for the exportation and transportation of live stock between States of the United States and foreign countries where he had reason to believe live-stock diseases existed. This act also empowered him to seize, quarantine, and dispose of any hay, straw, forage, or similar material, or any meats, hides, or other animal products coming from an infected foreign country to the United States, or from one State of the Union to another, whenever in his judgment such action was advisable in order to guard against the introduction or spread of live-stock contagion. Suitable penalties were enacted for violation of the statute or disregard of the regulations promulgated thereunder by the Secretary of Agriculture.

The statute accomplished in a measure the general results for which it was enacted, but did not entirely cover the necessities of the case, and, as the act was also held by the United States District Court for the District of Nebraska to be unconstitutional, so far as it empowered the Secretary to make rules and regulations violations



of which should constitute a crime, early in the third session of the Fifty-eighth Congress the Secretary recommended the enactment of a more comprehensive law which would give him the power, after ascertainment of the fact, to quarantine any State or Territory or portion thereof where contagious, infectious, or communicable live-stock diseases should be found to exist, in order that these diseases might not be spread through the medium of live stock which themselves might not be diseased. This recommendation resulted in the passage of the act of March 3, 1905, which is the act under which an epidemic of foot-and-mouth disease in 1908-9 was restricted to the localities in which it occurred until its successful eradication.

As a result of the administration of these acts the department has been able, during the 16 years covered by this report, to extirpate some of the most virulent live-stock diseases in large sections of the United States, with a consequent lifting of the Federal and State quarantine over substantial areas. This act was sustained as constitutional by the District Court of the United States for the Western District of Kentucky in December, 1908.

Between July 1, 1906, and June 30, 1912, 454 cases under the foregoing acts have been reported to the Attorney General, and of this number 160 cases have resulted in convictions and the imposition of fines amounting to \$16,375.

#### THE LACEY ACT.

The act of May 25, 1900, commonly known as the Lacey Act, was passed upon the recommendation of this department to meet two distinct evils: (1) The importation into the United States of animals and birds which were ascertained by the department to be destructive to crops and poultry, and (2) commerce between the States in game killed in violation of State laws. Under this act importation into the United States of the destructive fruit bats, mongooses, and other predatory species has been prevented, and impetus has been given to legislation in the several States for the protection both of game and nongame birds and mammals. In 1909 the department having found through its efforts to enforce this act that it could not be given the effective operation which was plainly intended by Congress until a provision was added prohibiting the shipment from one State to another of game shipped in violation of local law, as well as game killed in violation of local law, recommendation was made that, in the codification of the act for purposes of the Penal Code, an amendment be inserted to cover shipment of game in violation of State laws, as well as the shipment of game killed in violation of local laws. Evidence to establish the unlawful killing of game was difficult to pro-

cure, and the department found itself very much handicapped in the enforcement of this provision. The shipment of game in violation of local laws was as much within the spirit of the act as the shipment of game killed contrary to law.

Under the enlargement of the act, as it now appears in the Penal Code, the department has been able to report a substantial number of cases to the Attorney General, and success has crowned the efforts of the department to check illicit interstate commerce in game.

Since July 1, 1906, there have been reported to the Attorney General 74 cases for violation of the act, and convictions have been secured in 22 of these.

#### THE TWENTY-EIGHT HOUR LAW.

The act of June 29, 1906, commonly known as the twenty-eight hour law, is a reenactment, with substantial and important amendments, of the act of March 3, 1873. The original act was intended to prevent cruelty to animals while in transit in interstate commerce; but, in its endeavor to enforce the act, the department was confronted with several decisions of the courts which narrowed its operation to such an extent that the benefits which were expected to accrue from its execution were in a considerable measure lost.

It had been held that the law did not apply to the receivers of railroads, and that it did not cover animals moving from a State into a Territory, or from a Territory into a State; both serious omissions at that time. Under the old law animals in transit were unloaded under circumstances of brutality and into pens in which the mud was 2 feet or more deep. The facilities for feeding, watering, and resting in the pens into which they were unloaded were entirely inadequate. There was no provision in this law for the owner of the stock, if he so elected, to furnish their food, and the carriers, under the provision giving them a lien upon the stock for their food, accumulated exorbitant charges against the stockmen. The requirement was peremptory that the stock be unloaded at the expiration of 28 hours. This in many cases operated not only disadvantageously to the stock themselves, but also to the owners and shippers, since by continuing the trip a few more hours the stock could have been delivered at their destination under circumstances both humane to the animals and profitable to their owners. The amendments which were recommended by the department were embodied by Congress in the act of June 29, 1906, and the law has been rigidly enforced during the entire time since its passage.

Since July 1, 1906, there have been reported to the Attorney General 3,795 cases, of which 1,784 have resulted in judgments for the United States and the payment into the Treasury of \$212,745.

## FOOD AND DRUGS ACT.

The food and drugs act of June 30, 1906, was the result of repeated efforts of the department to secure the enactment by Congress of a law to suppress widespread adulteration and misbranding of foods and drugs passing in commerce between the several States and Territories and imported into the United States from foreign countries. Prior to the enactment of this law the department, after most exhaustive investigation, had determined the standards of purity which general opinion had established for the more important food products. Departures from these standards were the rule rather than the exception, and deceit in the manufacture and sale of foods and drugs had grown to such an extent that many manufacturers regarded any interference with their business as an invasion of vested rights.

Immediately upon the passage of the act the department organized the requisite force for its vigorous administration and has prosecuted its work under the act without abatement ever since. The constitutionality of the act has been sustained by a number of the Federal courts, and numerous decisions of the Federal courts have construed its provisions. During the operation of the law 3,456 cases have been reported to the Attorney General involving prosecutions against individuals and private corporations, resulting in 1,226 convictions and the imposition of fines amounting to \$47,982; 1,296 seizures of foods and drugs have been made, resulting in 867 decrees of forfeiture and condemnation. The department has published 1,626 notices of judgment as required by the act.

## MEAT-INSPECTION LAW.

The meat-inspection law of June 30, 1906, was the culmination of efforts of the department for years prior to secure the enactment of a law which would authorize rigid inspection of meat and meat-food products intended for interstate and foreign commerce. A makeshift statute was passed and approved August 30, 1890, but the statute did not provide for post-mortem inspection at the time of slaughter; furthermore, it was confined to salted pork and bacon intended for exportation to foreign countries the Governments of which should require inspection thereof. The measure failed of its purpose, however, for in the next annual report of the Secretary of Agriculture he urged the enactment of a law which would provide for national inspection of cattle at the time of slaughter. In compliance with the Secretary's recommendation, the act of March 3, 1891, was passed.

This act made it mandatory upon the Secretary to cause an ante-mortem inspection to be made of all cattle, sheep, and hogs which were the subject of interstate commerce and which were to be slaught-

ered, and at slaughterhouses, etc., and provided that there might also be made, when deemed by the Secretary of Agriculture advisable, a post-mortem examination. The restrictions which had theretofore been placed by foreign countries on the importation of meat-food products from the United States were in a measure removed.

Notwithstanding the benefits which accrued from the enforcement of this act to American producers of meats, the statute still failed to meet the continued and growing abuses in the production and packing of meats and meat-food products. In the spring of 1906 rumors gained credence that the packing houses of the country were not conducted in a sanitary manner and that the inspection under the acts of 1891 and 1895 was not conducted efficiently. The Secretary of Agriculture appointed a committee to investigate conditions at one of the large packing centers, and the President of the United States appointed a committee for the same purpose. When the report of the latter committee was received by the President, he transmitted it to Congress on June 4, 1906, accompanied by a message in which he stated that a law was needed to enable the inspectors of the General Government to inspect and supervise from the hoof to the can the preparation of meat-food products. The President recommended to Congress the passage of an act to provide for a Federal inspection of meats and meat-food products at all stages of preparation. The report of the committee appointed by the Secretary of Agriculture was also transmitted to Congress by the President. This report embodied the recommendation that interstate commerce in meat and meat-food products of cattle, sheep, swine, and goats be prohibited, unless they should be marked in accordance with the regulations of the Secretary of Agriculture to show that they had been inspected.

In compliance with these recommendations, Congress enacted the meat-inspection law of June 30, 1906, and under it the department has not only been enabled in a large measure to prevent interstate commerce in diseased and unsound meats and meat-food products, but it has also been able to enforce sanitary measures in the packing-houses.

There have been reported to the Attorney General 311 cases of violations of the meat-inspection law, of which 168 have resulted in convictions and the imposition of fines amounting to \$11,117, as well as a number of jail sentences.

#### INSECTICIDE AND FUNGICIDE ACT.

The insecticide and fungicide act of April 26, 1910, was passed by Congress in furtherance of the recommendation of the Secretary of Agriculture as a result of investigations which had been made by the department into the character and quality of material on the market and widely sold under representations of efficacy in the de-

struction of harmful and injurious insects and fungus diseases. The annual report of the Secretary of Agriculture for 1905 stated that the investigations of the department had shown that many of the insecticides offered to the farmers of this country are of little value and that the price demanded and the value of the goods are not always proportionate. Samples of insecticides widely in use were examined in the Bureau of Chemistry and found not only to want the efficacy ascribed to them, but also to be themselves more destructive than the insects or diseases they were intended to destroy. The act follows in substantial form the provisions of the food and drugs act of June 30, 1906, and is intended to suppress interstate commerce in adulterated and misbranded insecticides and fungicides.

There have been reported to the Attorney General for prosecution and for seizure of adulterated and misbranded goods 58 cases, and convictions have resulted in 7 cases.

#### PLANT QUARANTINE ACT.

The plant quarantine act of August 20, 1912, is the successful outcome of a number of attempts since 1899 to secure the enactment by Congress of a comprehensive law which would enable the Federal Government to prevent the importation into the United States from foreign countries of nursery stock infested with injurious insects or affected with plant diseases, and also to prevent the spread of insect pests and plant diseases from one State to another. The act in its general scheme follows the cattle quarantine law of 1905, and under its provisions the Department of Agriculture, by regulations promulgated by it, now has the power to control plant diseases and parasites coming into the United States, as well as those which originate in or are indigenous thereto.

#### TRESPASSES ON NATIONAL FORESTS.

The creation of National Forests out of lands in the public domain suitable for the purpose was authorized by the act of March 3, 1891, and the jurisdiction over them was conferred upon the Secretary of the Interior by the act of June 4, 1897. This jurisdiction continued until February 1, 1905, when it was transferred to the Secretary of Agriculture. Since the transfer of this jurisdiction the National Forests have multiplied in number and increased in territory until, at the present time, there are nearly two hundred million acres of public lands reserved as National Forests.

From February, 1905, until December, 1908, the department endeavored to administer the forests from Washington, but the increase in extent of the forests and the increasing use of the lands for purposes authorized by law plainly indicated that the only successful

method of administering them lay in the organization and maintenance of districts with headquarters at a convenient point in each district. So, on December 1, 1908, 6 districts were organized in the West, where, of course, all the National Forests were situated. This system has resulted in their successful and businesslike administration.

Prior to the creation of the National Forests stockmen were accustomed to use the lands embraced in them without regulation in any respect by the Government, and the Government not only received no return for the valuable resources furnished, but there was also constant friction, sometimes even approaching border warfare, between owners of different kinds of stock, or even between owners of the same kinds, growing out of the natural tendency of individuals to monopolize the more valuable areas for their own profit. The department, under its authority to regulate the use of the lands in the National Forests, has by carefully planned regulations provided for the use of grazing lands, and all stockmen are afforded an opportunity to enjoy the privileges which the forests can provide and the Government receives a compensation for the use of its grazing lands. Some hostility to the permit system of administering the grazing lands was encountered for a time, but it can confidently be said that the stockmen of the West now regard the administration of grazing lands on the National Forests as conducive to the peace and welfare of everyone who desires to graze stock thereon. Since the Department of Agriculture assumed control of the National Forests the returns from grazing permits have averaged \$1,000,000 a year, and at the same time users of the forests have had the benefit of a rate of charge much below the rate prevailing on private lands in the same vicinity. The validity of the grazing regulations has been sustained by the United States Supreme Court.

At the time of the transfer of jurisdiction over the National Forests to the Secretary of Agriculture a number of very extensive timber trespasses had been committed, both on lands prior and subsequent to their inclusion in forest reserves. The department made careful investigation into all these trespasses, and during the last two or three years brought them to the attention of the Attorney General. Suits were instituted, and the Government has recovered upwards of half a million dollars for these depredations, some of which were begun 20 years ago. Sales of timber from the forests have averaged three-quarters of a million dollars a year since this department assumed control of them, and, at the same time, the condition of standing timber has been greatly improved by silvicultural investigation and experiments, and large areas where trees never grew have been seeded and forested.

## ILLEGAL CLAIMS TO LANDS IN THE NATIONAL FORESTS.

The department has worked out a system of water-power control which is under most successful operation at the present time. It is, of course, natural in the administration of nearly 200 million acres of land under regulations which permit the use of the lands for private purposes that numerous and important legal questions will arise, to say nothing of the preparation of necessary contracts and other instruments to perform properly the business of the department in connection with these lands. These exigencies made it imperative that legal assistants should be detailed to the 6 Forest Service districts for the performance of the legal work of these districts. Since the spring of 1910 these legal assistants have been in the office and under the supervision of the Solicitor of the department. Two have been assigned to each of the districts, except that in districts 4 and 5, where it has been found possible to perform the work with one assistant, only one has been assigned to each. The work of these district assistants to the Solicitor is varied and extensive, including preparation of all contracts and other written documents, legal advice to the district foresters, assistance to the United States attorneys handling the department's cases, and cooperation with the agents of the Interior Department in the prevention of both illegal and unwarranted acquisition by individuals of lands in the National Forests under the various public land laws. Many of these claims were and are known or believed to be either fraudulent or without warrant of law. It was and is, therefore, the duty of the Secretary of Agriculture, as custodian of these lands, to see that these claims were and are not allowed to be perfected and title procured by patent. The department's efforts to defeat fraudulent and unauthorized claims to lands in the National Forests had been successful in a large measure, but it was realized that closer cooperation between the Department of the Interior and the Department of Agriculture was requisite to that degree of success which would insure the best results for the Government.

With such cooperation in view, the two departments, in June, 1910, entered into an agreement by which the Department of Agriculture was to be recognized in the Interior Department as an active contestant in all claims cases against which an adverse report was made by forest officers. This agreement embodied also the provision that the law officers of the Department of Agriculture should have the right to attend and participate in all hearings ordered by the Department of the Interior for the taking of testimony; and the right of appeal from decisions of the Commissioner of the General Land Office adverse to the Government in Forest Service cases was likewise accorded the law officers of the Department of Agriculture.

Since this agreement went into force the efforts of the department to defeat fraudulent and unwarranted claims to lands have been crowned with conspicuous success.

#### LEGAL BUSINESS FOR THE FOREST SERVICE.

A record of the legal business for the Forest Service has been preserved since February, 1910, and some estimate of the extent and scope of this work may be gathered from the following brief summary of cases handled during that time:

The Solicitor of the department has rendered 2,627 written opinions to the Forest Service on legal questions arising in the administration of the National Forests; upward of 3,000 cases involving claims to lands under public-land laws have been handled, of which fully two-thirds have been decided in favor of the Government; 73 cases of illegal occupancy of lands in the National Forests have been reported to the Attorney General; 193 grazing trespass cases have been similarly reported, resulting in the recovery of damages to the amount of \$5,890 actual and \$1,525 punitive and fines to the extent of \$1,173; 98 fire trespass cases have been reported, resulting in the imposition of fines amounting to \$1,178 and the collection of damages to the amount of \$61,427, and in addition 62 prosecutions have been maintained under State laws, resulting in 52 convictions; 122 timber trespass cases have been reported to the Attorney General, resulting in the recovery of damages to the extent of \$316,862 and the imposition of fines amounting to upward of \$500, together with several jail sentences. Besides cases reported to the Attorney General, administrative settlements for trespasses on the forests have been made in 224 cases, resulting in the payment to the Government of \$31,643.

#### WEEKS FORESTRY LAW.

The maintenance and administration of the National Forests in the West having demonstrated the importance of protection of forest lands as a means of conserving and promoting water flow, the department for a number of years past urged upon Congress the advisability of the acquisition of timbered lands in the East as a means of conserving and promoting the navigability of navigable streams in the Eastern States where the Government has never owned lands. Especial attention was called to the rapid disappearance under wasteful methods of large areas of timber on the watersheds of important navigable streams in and contiguous to the Appalachian Mountain Range. The recommendations of the department culminated in the act of March 1, 1911, commonly known as the Weeks Forestry Law, under which the Secretary of Agriculture is authorized to examine, locate, and recommend for purchase such lands as, in his judgment,



may be necessary for the regulation of the flow of navigable streams, and to report the results of such examinations to a commission created by the act and designated the National Forest Reservation Commission.

Upon the approval of the purchase by the commission the Secretary is authorized to purchase the lands for the United States and thereafter to organize them into National Forests, to be administered, with certain limitations, as other National Forests are administered. An appropriation of \$13,000,000 was made for purposes of the act, and active operations were commenced immediately upon its approval.

There are at present 45 contracts with owners of lands to convey to the Government lands aggregating 268,627 acres, situated in New Hampshire, Virginia, Tennessee, North Carolina, and Georgia. Negotiations are being conducted for the purchase of additional areas in these States and others where the control of forests is essential to a conservation of the water flow in navigable rivers. One tract of 8,213 acres in North Carolina has already been acquired by the Government, and another tract of 32,000 acres in Georgia will be acquired as soon as adjustment can be had in the condemnation proceedings pending. The department's record examiners attached to the Office of the Solicitor have already examined the titles to a large portion of the lands embraced within the contracts for conveyance to the United States, and in several cases their reports have been submitted to the Attorney General.

#### CONCLUSION.

The record of 16 years has been written. It begins with a yearly farm production worth \$4,000,000,000 and ends with \$9,532,000,000. Then, farmers were loaded with debts that were a painful burden; prosperity followed and grew with unexampled speed. Then, the farmer was a joke of the caricaturist; now he is like the stone that was rejected by the builder and has become the head stone of the corner. Beginnings have been made in a production per acre increasing faster than the natural increase of population. There has been an uplift of agriculture and of country life.

In this movement the department has been gradually equipped to occupy a foremost place. It came to learn and it remained to teach. Its influence penetrates the remotest neighborhood. It performs a mission of welfare and happiness to farmers and to the whole Nation. The millions of dollars that it costs are returned in tens of millions of wealth saved and wealth produced.

The department is prepared to continue and increase its public service. During 16 years it has progressed from the kindergarten through the primary, middle, and upper grades of development until now it has a thousand tongues that speak with authority. Its teach-

ings, its discoveries, and its improvements are permeating the national agricultural life. The forces that are at work must cause ever-increasing results.

The great and growing movement carried on by the department for agricultural betterment has not been sustained solely by one man, nor by a few men. A choice corps of scholarly experts in their special lines of endeavor has been growing in membership, in breadth of view, and in the practical application of their efforts. They have been and are men both good and true, men with high ideals, often sacrificing greater remuneration in private employment for love of the great results of their public service. No great work can be begun, nor sustained, by this department without such men.

Men grow old in service and in years, and cease their labor, but the results of their labor and the children of their brains will live on; and may whatever of worth that is in these be everblooming.

Respectfully submitted.

JAMES WILSON,  
*Secretary of Agriculture.*

WASHINGTON, D. C., *November 27, 1912.*



## PROMISING NEW FRUITS.

By WILLIAM A. TAYLOR, *Pomologist and Chief*, and H. P. GOULD, *Pomologist in Charge of Fruit District Investigations, Bureau of Plant Industry.*

### INTRODUCTION.

This paper is the twelfth in a series which was begun in the Year-book for 1901. The primary object throughout the series has been to discuss fruit varieties that are little known among fruit growers, but which are believed to possess qualities that make them inherently valuable in their places of origin and worthy of testing elsewhere.

The "variety problem" is one that is ever before the grower who views the fruit industry either from the standpoint of the student or that of the business man. In the last analysis commercial fruit growing, to be permanently successful, must be considered from both of these standpoints. In one form or another the variety question has long been prominent in the minds of those interested in the production of fruit in the United States and Canada. Reference to the earlier proceedings of the American Pomological Society discloses the fact that for many years its meetings were devoted largely to discussion of the relative merit of different varieties for the various sections of the country. The "fruit lists" of varieties recommended for planting which resulted from these discussions and the work of committees appointed to give the matter more systematic consideration have been a potent influence for good in the development of the fruit industry of the country.

As the business aspects of fruit growing receive more definite recognition varieties will be planted more and more to meet particular conditions and for special rather than for general purposes. For instance, under present conditions one of the most important requirements of a winter apple in many sections is that it have good cold-storage qualities, and a variety may be selected for commercial planting or discarded on account of its behavior in this one particular. Again, summer apples were, for a considerable period, a very minor consideration commercially, but within the past 10 or 15 years there has developed an important demand in the eastern markets for this class of fruit. This has greatly stimulated the planting of early apple varieties in many sections where formerly they were little valued.

Such changes in conditions as have been mentioned necessarily have an important bearing on the question of varieties, and their influence must continue until the attainable degree of perfection in varieties to meet the more important demands is reached. Moreover, in the case of such fruits as the avocado, the mango, and some others, the commercial culture of which is comparatively new, there are as yet but few varieties in cultivation in this country. As the market demand for these newer fruits increases and their culture becomes of greater commercial importance, new and better varieties or varieties better adapted to commercial needs will in all probability be developed.

The Department of Agriculture has no stock for dissemination of any of the varieties referred to in this paper.

#### EASTMAN APPLE.

SYNONYMS: *Fameuse Seedling*, *Fameuse No. 1*, *Patten's Fameuse*.

[PLATE I.]

#### EARLY HISTORY.

The pioneer attempts at fruit growing in northern Iowa early demonstrated that the varieties with which the early settlers were familiar in their old homes in the East were not hardy enough to withstand the dry, cold winters characteristic of a large portion of the upper Mississippi Valley.

The Eastman apple is of interest in pomology not only because of its merit as a variety, but because it is one of the results of a definitely planned effort to develop varieties adapted to the peculiar needs of this region. It originated at Charles City, Iowa, from a seed of a Fameuse apple which was planted in the spring of 1874 by Mr. Charles G. Patten. The pollen parent of the Eastman is unknown, but the apple from which the seed was obtained grew in Mr. Patten's orchard at Charles City, where there were also growing trees of the St. Lawrence, Oldenburg, and Wealthy apples. The Eastman is, therefore, probably a cross between the Fameuse and one of these varieties.<sup>1</sup>

This variety was first offered to the trade in the spring of 1884, and the synonyms named above were used at various times by Mr. Patten in his catalogues. But, as none of these names seemed to be suitable, he subsequently applied the name "Eastman" in honor of Mr. P. S. Eastman, formerly of Iowa but now residing at Berkeley, Cal., who supplied the Oldenburg apple from a seed of which the Patten<sup>2</sup> (*Patten Greening*) apple originated.

<sup>1</sup> Letters from Mr. Charles G. Patten, October and November, 1912.

<sup>2</sup> For description and illustration, see Yearbook, U. S. Dept. of Agriculture, for 1908, p. 474.

The tree makes a strong, vigorous, spreading growth and is conceded to be decidedly more hardy than its parent, the Fameuse, and equal in hardiness to the Wealthy. It has proved to be a remarkably early, regular, and prolific bearer. For some years it has been giving good satisfaction in central Iowa, as well as in various sections of Minnesota. It seems to do well in the Bayfield Peninsula region of Wisconsin, and Mr. Eastman has recently fruited it at Berkeley, Cal., where it is considered by him to be a promising variety.

The original tree became weakened by mechanical injuries and was cut down in 1910, though still bearing fruit.

DESCRIPTION.<sup>1</sup>

Form roundish, slightly truncate, sides often unequal; size large; cavity regular, large, deep, slope gradual, somewhat russeted; stem of medium length, rather slender; basin irregular, very large, deep, slope abrupt, furrowed; calyx small, closed; eye small, funnel form; surface smooth except indistinct ribbing; color pale yellow, heavily washed with delicate bright red in highly colored specimens and marked with broken stripes and splashes of light carmine; dots numerous, small; flesh whitish; texture rather coarse, tender, moderately juicy; core roundish conic, clasping the long calyx tube, size medium, slightly open; seeds few, plump, medium size, color rich brown; flavor mild subacid, moderately rich, pleasant; quality good. Season in locality of origin, late fall, ripening just after the Wealthy apple.

The specimen illustrated in Plate I was grown by the originator at Charles City, Floyd County, Iowa, in 1912.

## MONOCACY APPLE.

SYNONYMS: *Hoop, Baumgardner, Bill Baumgardner, Smith.*

[PLATE II.]

## EARLY HISTORY.

The Monocacy apple is one of many examples of fruit varieties that apparently possess great potential possibilities and have long been grown in very restricted regions, where they are highly esteemed, but which remain quite unknown to fruit growers generally.

The history of this variety as recalled by Mr. Frederick Dorcus, of Carroll County, Md., who is now 81 years of age, supplied in the present connection by Mr. Jesse P. Weybright,<sup>2</sup> also of Carroll

<sup>1</sup> The varietal descriptions of the Eastman and Summer King apples, the Chesapeake strawberry, and the Pollock avocado used in this paper are based on data in the Office of Pomological Collections, Bureau of Plant Industry.

<sup>2</sup> Letters from Mr. Weybright, September and November, 1912.

County, is substantially as follows, the account of the original tree beginning with the year 1849, when Mr. Dorcus remembers eating apples which it produced:

The tree stood on a farm owned by Mr. William Baumgardner, which was located on the Monocacy River, in Carroll County, at the mouth of Piney Creek and about 7 miles southwest of Taneytown. This farm is now owned by Mr. Aaron Veant.<sup>1</sup>

The tree was considered a wilding and the fruit was so hard in the fall that it was not usually gathered. About Christmas time, however, during these early years, Mr. Dorcus would go to the tree, secure the frozen apples, and, after thawing them, would eat them.

Apparently this variety came into local prominence about 1859 or 1860 through a Mr. Seiss, who lived in a tenant house on the "Baumgardner farm" and who helped pick the apples. When the crop was harvested that fall, the fruit on this tree being left untouched, as was the usual practice, Mr. Seiss obtained the permission of Mr. Baumgardner to gather it for himself. This he did, picking 30 bushels, which he took home and buried in a pit. He kept them in this manner till late the following spring after the apples of everyone else were all gone. At this season they were of such high quality that they attracted much attention and apparently created considerable local excitement.

At about this time (1859 or 1860) Abram and Isaac Furney were growing nursery trees near Taneytown, Carroll County. They grafted a considerable number of trees of this variety, and these became known locally as the "Hoop" apple. Apparently these were the first trees of the variety to be propagated in a nursery.

Recollection as to the location of the original tree differs somewhat. Mr. Dorcus recalls it as being in a field near a ravine, standing apart from any other trees, while others say that it stood in the orchard on the Baumgardner farm; but as to the more important features, this account appears to be well authenticated.

There is another account<sup>2</sup> of this variety which locates the original tree about one-half mile from Woodsboro, Frederick County, Md., on a farm owned at the time by the late George Livingston Smith. When Mr. Smith gathered his apples in the fall of 1865 he was attracted by this particular variety, which apparently had remained unnoticed in previous years. It is stated that after due effort had been made to ascertain the name of the variety without success he called it the "Smith" apple. This name is still applied to this variety in some localities in Frederick County.

---

<sup>1</sup> Letter from Mr. Veant, November, 1912.

<sup>2</sup> Letters from Mr. D. A. Sharetts, October, 1912; also from Mr. Charles E. Klein, November, 1912.

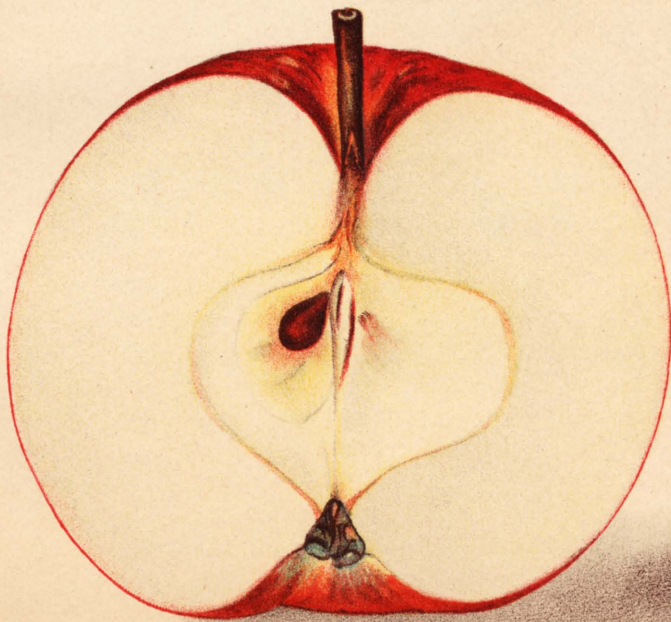

EASTMAN APPLE.

*Mary D. Arnold*

JULIUS BIEN CO. LITH. N.Y.



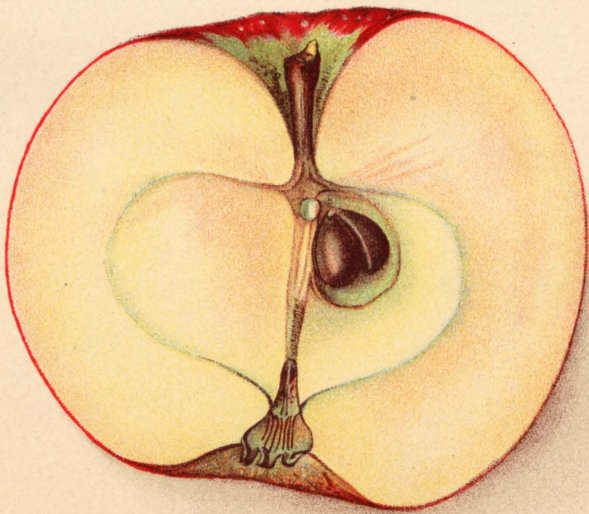

*E. J. Schutt.*

MONOCACY APPLE.

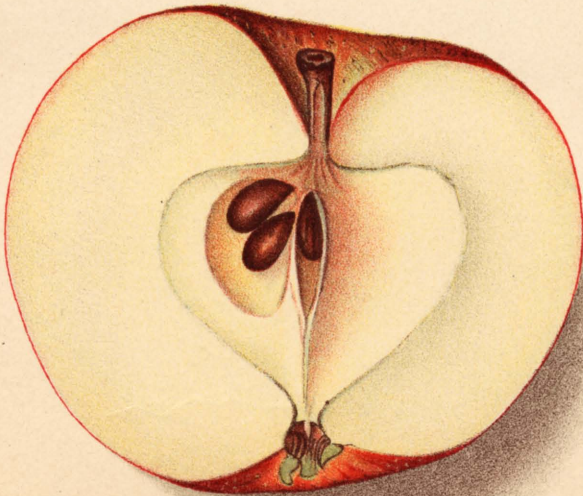

*E. J. Schutt.*

SUMMER KING APPLE.





DOUGLAS PEAR.

*E. J. Schutt.*

JULIUS BIEN CO. LITH. N.Y.

As the "Smith farm," near Woodsboro, is but 9 or 10 miles distant from the "Baumgardner place," referred to in the earlier account, the occurrence of a tree or trees of the variety of fruiting age at Woodsboro as early as 1865 is not difficult of satisfactory explanation.

As already indicated, the names "Smith" and "Hoop" are applied locally to this apple; in other localities it is still known as the "Baumgardner" or "Bill Baumgardner" apple. The name "Monocacy," so far as known, was first suggested for this variety in 1897 by Mr. J. A. Ramsburg,<sup>1</sup> of Frederick, Md. The identity of the variety was then apparently unknown to him, and because of the fact that it originated near and for many years had been considerably grown at points in the vicinity of the Monocacy River this name seemed to be an appropriate one. In recent years the name "Monocacy" has become more widely known than any one of the others, the variety having been commercially propagated and disseminated under this designation. So far as known, the other names, though in use locally for many years before the name "Monocacy" was suggested, have not previously been published in connection with the variety.

Though this variety has become somewhat more widely distributed in recent years, it remains very largely unknown except in the northeastern portion of Frederick and the western part of Carroll County, Md. It is to be found in many small home orchards in this region, where in most cases its distribution has been by means of scions top-worked into trees of bearing age.

The original tree died some years ago, having become greatly weakened, it is said, from the excessive cutting of scions from it.

#### DESCRIPTION.

Form roundish, some specimens slightly oblate conic, sometimes slightly ribbed; size medium to large; cavity regular, medium to large, rather deep, slope abrupt, sometimes slightly russeted, but without markings in the majority of specimens; stem short, rather slender; basin regular, medium in size and depth, slope gradual, some leather cracking, slightly furrowed; calyx segments medium to large, converging; eye rather large, closed or nearly so; surface smooth; color yellowish green, almost entirely overspread with dark crimson, shading to a purplish crimson in very highly colored specimens, splashed and striped with darker crimson, with an overspread of mottled gray in many specimens; dots yellowish white, rather numerous, increasing in numbers toward the apex, rather large and conspicuous; skin moderately thick, tenacious, and firm; flesh yellowish white, sometimes slightly tinted with red; texture moderately fine grained, juicy; core large, oblate, clasping, closed or par-

---

<sup>1</sup> Letter from Mr. Ramsburg, October, 1897.

tially open; carpels rather small, nearly circular; seeds numerous, of medium size, plump, rich dark brown; flavor mild, subacid, pleasant, moderately rich; quality good to very good. It is prized by those who know the variety best both for culinary and dessert purposes. Season, winter, keeping till late winter and sometimes well into the spring in the region in Maryland in which it is most largely grown. It is reported to be an excellent variety for cold storage.

The tree attains only moderate size, but is vigorous and healthy; the wood is very tough; limbs not easily broken by heavy crops. It is said to bear young, frequently fruiting at from 4 to 6 years of age, and to be a long-lived tree and a heavy, regular bearer.

The universal esteem in which the Monocacy apple is held in the region in which it is best known indicates an apple of much merit. Though its color may be a little dark, it is attractive in appearance and its quality is sufficiently high to give it value. It is considered worthy of extended trial, especially in middle latitudes.

The specimen illustrated in Plate II was grown by Mr. Edward Shorb, Keymar, Carroll County, Md., in 1912.

#### SUMMER KING APPLE.

SYNONYMS: *Kentucky Summer Queen, Bounty.*

[PLATE III.]

#### EARLY HISTORY.

The early history of the Summer King apple is obscure. It appears to have been a relatively prominent variety in Warren County, Ky., during the middle of the last century, where it is supposed to have been introduced by the early settlers from North Carolina about 1810 or 1815. More definite records regarding its origin are wanting. It seems never to have become much known in North Carolina, and at the present time it is very rarely found in that State.

It was introduced into eastern Kansas about 1860, but it appears not to have become of commercial importance in that region. More recently it has been grown to a limited extent in Maryland, where it is very highly esteemed. It has also been received at the Department of Agriculture from Tennessee and New Jersey, but the variety is unknown to most fruit growers. It is said to have been known in Kentucky in the earlier years under the name of "King," but to distinguish it from other varieties having that name the prefix "Summer" was added by the late Dr. William M. Howsley,<sup>1</sup> of Kansas.

<sup>1</sup> Manuscript notes of the late Charles Downing.

## DESCRIPTION.

Form roundish; size medium to large; cavity regular, of medium size and depth, slope gradual, with russet markings; stem short, stout; basin regular, small, of medium depth, slope gradual, sometimes slightly furrowed; calyx segments rather short, wide, converging; eye small, closed; surface smooth; color greenish yellow, washed and marbled with mixed red and broken stripes of crimson and over-spread of gray; dots numerous, rather conspicuous, yellowish or light gray, sometimes russet; skin moderately thick, tenacious; flesh whitish yellow, fine grained, tender, juicy; core oblate conic to roundish conic, large, clasping, partially open; seeds few as a rule, plump, large, color light brown; flavor mild, pleasant subacid; quality good to very good. Season, early August in eastern Maryland, continuing for two or three weeks.

The tree makes a thrifty, straight growth in the nursery and forms an upright, round, symmetrical head in the orchard. It comes into bearing early and is considered productive.<sup>1</sup>

On account of the beauty and high quality of this variety and the productiveness of the tree it is apparently worthy of a more prominent place in the early-apple industry of middle latitudes and the South than it holds at the present time.

The specimen illustrated in Plate III was received through Mr. J. W. Kerr, Denton, Caroline County, Md., in 1912.

## DOUGLAS PEAR.

[PLATE IV.]

## EARLY HISTORY.

The Douglas pear originated with Mr. O. H. Ayer, near Lawrence, Douglas County, Kans., as did the Ayer pear.<sup>2</sup> The exact year of its origin is not a matter of definite record, though it was about 1897. It came from a seed of the Kieffer pear and is supposed to be a hybrid between that variety and the Angouleme (*Duchesse d'Angouleme*). It first fruited in 1902. During that season the fruit was exhibited before the local county horticultural society, where it attracted the attention of Mr. A. H. Griesa, of Lawrence, who later that same season made an examination of the tree. It was then standing in a much overcrowded row of seedling pear trees and was the only one of the entire collection to fruit that year. The general appearance of the tree, the character of the foliage, and

<sup>1</sup> Letter from Mr. J. W. Kerr, November, 1912.

<sup>2</sup> For description of the Ayer pear, see Yearbook, U. S. Dept. of Agriculture, for 1911, p. 428.

the buds were especially good, and Mr. Griesa at once became interested in it. It was at his suggestion that the name "Douglas," the county in which it originated, was applied to it. Though it has been known locally for several years by this name, the latter does not appear to have been published until it appeared in a leaflet issued by Mr. Griesa in 1910. The variety was first propagated by him in 1907, but not disseminated until 1911.

In growth the tree is said to resemble the Angouleme. Thus far, in the region in which it originated it has been entirely free from blight, though other pear trees in the same locality have blighted seriously. Bearing begins remarkably early; trees 2 and 3 years old frequently producing some fruit. It blossoms a few days later than the Kieffer, or about with the Angouleme. The original tree is still in good thrifty condition.<sup>1</sup>

#### DESCRIPTION.

Form obovate or roundish obovate; size medium to large; cavity regular, medium to large, depth medium, slope gradual, slightly russeted; stem very long, rather slender; basin slightly irregular, medium in size; rather shallow, slope gradual, slightly ribbed; calyx segments short, fleshy, converging; eye medium, open or partially closed; surface smooth except where slight undulations occur, sometimes slightly russeted in small patches; color yellow, characteristically blotched and mottled with small irregular scarlet markings on the exposed side, dots numerous, in many cases appearing as minute russeted spots; skin thin; core oval, clasping, rather large, closed; seeds of medium size, not very plump, dark brown; flesh whitish or greenish white, moderately fine grained, melting, very juicy, with occasional coarse granules in the flesh; flavor subacid, with slight astringency; quality good; season about with the Kieffer or a little earlier—from the first to the middle of October in the locality of its origin.

Though this variety does not rate as high in flavor and dessert quality as many varieties, it is distinctly better than the Kieffer and is particularly attractive in appearance. The vigor and healthfulness of the tree, and especially its freedom from blight, make it a promising new variety and one that should be widely tested.

The specimen illustrated in Plate IV was grown by Mr. A. H. Griesa, Lawrence, Douglas County, Kans., in 1912.

---

<sup>1</sup> Letter from Mr. A. H. Griesa, May, 1912.

## CHESAPEAKE STRAWBERRY.

[PLATE V.]

## EARLY HISTORY.

The Chesapeake strawberry originated as a chance seedling of unknown parentage with Mr. George W. Parks, of Nanticoke, Wicomico County, Md. The site of its origin was on Nanticoke Point, within a short distance of Chesapeake Bay; hence its name, which was selected by the introducer and first published in 1906. when the variety was originally offered to the trade.<sup>1</sup>

The plants are vigorous, with thick, leathery, healthy foliage, which is borne on upright leafstalks. The plant is not prolific of runners, but under most conditions enough so for fruiting purposes. The blossoms are perfect; the flower trusses rather short but erect. It sets only a moderate quantity of fruit, but the tendency for every berry that forms to develop into a perfect specimen is exceptionally strong. No marked soil preferences are thus far indicated, as it appears to do well on nearly all types that are suitable for the growing of the well-known varieties of strawberries.

## DESCRIPTION.

Form roundish conic, often with wedge-shaped apex; size quite uniformly large; stem  $1\frac{1}{2}$  to 3 inches long, rather stout; calyx dark green, of medium size; sepals 10 to 16, rather closely adherent; apex regular, usually ripening uniformly; surface glossy; color rich crimson, durable; seeds regularly placed, numerous, medium to large, rather conspicuous, projecting slightly above the surface; flesh light red or crimson; texture meaty, tender, but firm; usually solid, but sometimes showing slight cavities in the center, juicy; shipping quality excellent; flavor rich, subacid, nearly sweet; aroma very pleasant; quality very good. Season late, beginning to ripen three or four days in advance of Gandy, which for many years has been very widely planted as the leading late commercial variety in the Middle Atlantic States.

The Chesapeake strawberry has been planted in many sections since it was introduced, and apparently with quite uniformly satisfactory results. It appears to be one of the most valuable of the newer varieties.

The specimens illustrated in Plate V were grown by Mr. C. P. Close, College Park, Prince Georges County, Md., in 1912.

---

<sup>1</sup> Letter from Mr. W. F. Allen, June, 1912.



## ORMOND PERSIMMON.

SYNONYMS: *Bostrom*, *Vining's Winter*, *Ormond Winter*.

[PLATE VI.]

## EARLY HISTORY.

The Ormond persimmon belongs to the oriental species *Diospyros kaki*. Its early history is somewhat uncertain. The original tree was apparently sent from Washington, D. C., supposedly by the Department of Agriculture, to the Rev. E. Y. Pinkerton, at Ormond, Fla. There is a difference of opinion, or recollection, at the present time with reference to when this occurred. Mr. J. A. Bostrom<sup>1</sup> places it about the year 1870, but Mr. James P. Vining,<sup>2</sup> who has known the variety for many years, has assumed a date several years later than this, his conclusion being based on the time of certain property transfers which occurred in the late eighties. But there appears to be a unity of statement regarding the general facts of the case.

The tree was planted by Mr. Bostrom for Mr. Pinkerton, and, as recalled by the former, it was about the size of a lead pencil and apparently a seedling, as it bore no signs of having been budded or grafted. At the time the tree came into Mr. Bostrom's hands there was a side branch which had developed from a point near the crown. When it was planted this branch was cut off and grafted by Mr. Bostrom into a wild persimmon tree on his own place.

On account of the enforced absence of Mr. Pinkerton the tree received but little care and soon died. However, Mr. Bostrom's graft grew, and within a year or two it began to fruit. The tree which developed from this graft is still in the possession of its original owner and is in a thrifty condition.

According to Mr. Vining, the fruit at first was not recognized as of any special value, but later, because of its long-keeping characteristics, it attracted attention.

This variety has been propagated locally to a limited extent for some years. It is known to some about Ormond as the "Bostrom" persimmon. In 1909 it was offered to the trade by Griffing Brothers Co., of Jacksonville, Fla., and catalogued under the name "Vining's Winter," but at the request of Mr. Vining it was listed the following year as "Ormond Winter." Under the code of nomenclature of the American Pomological Society this name is reduced to Ormond.

---

<sup>1</sup> Letter from Mr. Bostrom, January, 1913.

<sup>2</sup> Letter from Mr. Vining, June, 1911.

## DESCRIPTION.

Form oblong; size small to medium in comparison with many of the more widely known Japanese varieties; cavity even with surface, somewhat corrugated and furrowed; calyx large, lobes strongly reflexed; apex a raised point with four indistinct furrows radiating from it; surface smooth; color yellowish red; dots minute, scattering; skin thin, rather tender; bloom whitish; flesh of very deep orange color with reddish tinge toward center; texture meaty, tender, only moderately juicy, with rather numerous small fibers extending nearly entire length; seeds long and rather large, number variable, first fruits to ripen usually containing one or more, later fruits mostly seedless or at most containing only undeveloped rudimentary seeds; flavor sweet, fairly rich, losing all astringency when soft; quality good to very good. The first fruits to ripen, which are usually imperfect, reach maturity in November and December; the bulk of the crop, however, retains its firmness, and at Ormond it is usually gathered about the last week in December in order to avoid the effects of the relatively low temperatures that are likely to occur after that time. The foliage usually drops considerably before the fruit is picked. While a temperature of 25° F. is said to have no very appreciable effect on the fruit, if subjected to one below 25° F. it causes the fruits to soften, and fermentation soon follows.<sup>1</sup>

After the fruit is picked, if it is held in a cool place it matures gradually, some of the specimens retaining their firmness until February and March, or even later in some instances.

The tree makes a vigorous, upright growth and bears abundantly and regularly. The foliage usually drops in early December in the latitude of Ormond, and where the fruit is allowed to remain on the trees, as is commonly done, till the end of that month or early January, the heavily loaded branches produce a striking effect.

The late season and long-keeping qualities of this fruit, together with its heavy and regular bearing proclivities and its pleasing dessert quality, make it a variety among the Japanese persimmons having quite unusual characteristics. It should be widely tested, but on account of its lateness in maturing it may be expected to succeed best in the more southern Japanese persimmon districts.

The specimens illustrated in Plate VI were received from Mr. James P. Vining, Ormond, Volusia County, Fla., in 1911.

---

<sup>1</sup> Letter from Mr. Vining, December, 1911.

## POLLOCK AVOCADO.

[PLATE VII.]

## EARLY HISTORY.

The Pollock avocado originated on the grounds of Mr. S. H. Pollock, of Miami, Fla., about 1896 or 1897. The seed from which the original tree grew was obtained from a fruit produced on a tree also owned by Mr. Pollock, which it is claimed was brought from Cuba.<sup>1</sup>

The present name, given in honor of the originator, was in local use as early as 1901, when budded trees of it under this designation were commercially disseminated by Mr. George B. Cellon, of Miami. The original tree is still in good condition. Fruit was exhibited at the meeting of the American Pomological Society, which was held in Boston, Mass., in September, 1903.<sup>2</sup>

This variety has been grown to some extent in the work of the Office of Foreign Seed and Plant Introduction of the Bureau of Plant Industry of this department and inventoried as S. P. I. No. 12936.<sup>3</sup>

## DESCRIPTION.

Form pyriform; size very large, sometimes weighing 3 pounds or even more; cavity regular, size and depth medium, slope gradual, furrowed; apex a small point; surface undulating, indented; color greenish with yellow marblings and indistinct purplish stripes; dots numerous, brown, indented; flesh yellow with purplish veins, buttery, tender; seed obconic, medium in size in comparison with fruit, nearly filling cavity; flavor mild, very pleasant; quality very good; season August and September, sometimes extending into October in southern Florida.

The tree makes only a moderate growth and produces a fair number of very large fruits. Though much less important commercially than the Trapp avocado,<sup>4</sup> which in this respect leads all other sorts grown in Florida, it is perhaps surpassed only by that variety in the esteem in which it is held, its large size and high dessert quality being its chief distinguishing characteristics.

The specimen illustrated in Plate VII was grown at the Subtropical Plant Introduction Garden of the Bureau of Plant Industry, Miami, Dade County, Fla., in 1912.

<sup>1</sup> Letter from Mr. Edward Simmonds, Subtropical Plant Introduction Garden, Miami, Fla., December, 1912.

<sup>2</sup> Letter from Prof. P. H. Rolfs, November, 1912.

<sup>3</sup> Bureau of Plant Industry, Bulletin 97 (Inventory No. 11), p. 119.

<sup>4</sup> For description and illustration, see Yearbook, U. S. Dept. of Agriculture, for 1905, p. 508.



CHESAPEAKE STRAWBERRY.





ORMOND PERSIMMON.

*A. Newton*

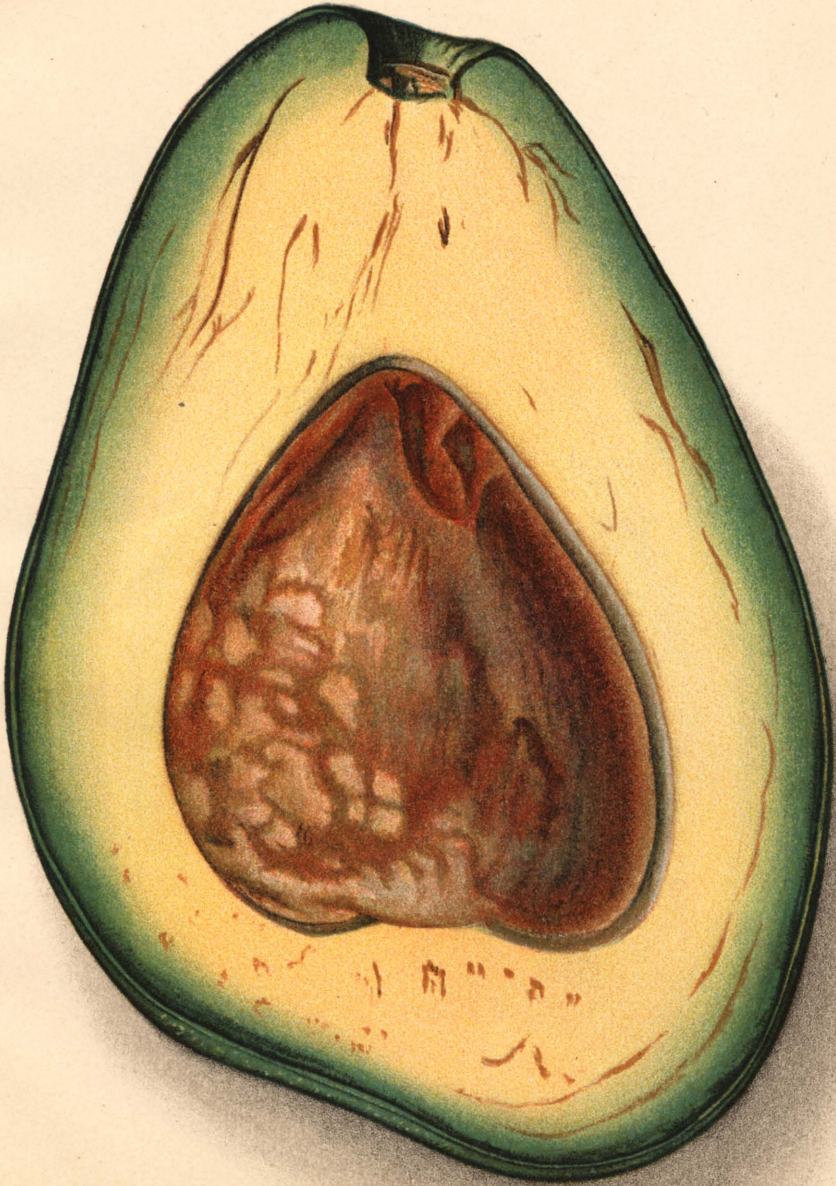

*E. J. Schutt.*

POLLOCK AVOCADO.





MAJOR

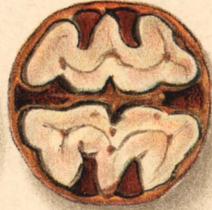

BURKETT

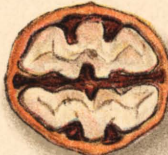

WARRICK



HAVENS



OWENS

*E. S. Schutt.*

MAJOR, BURKETT, WARRICK, HAVENS, AND OWENS PECANS.

## PECANS.

[PLATE VIII.]

Until quite recent years planters of pecan trees have been greatly handicapped in the selection of varieties because of the limited number of choice sorts which have shown special adaptability to particular localities. In comparison with most other fruits the number of varieties available in the form of budded or grafted trees has been very small, and of most varieties but a small stock was carried by the nurseries. Planters frequently have been satisfied with pecan trees merely because they were "grafted" or "budded," without regard to the variety or its adaptability to local conditions, and not infrequently the varieties have been of a "selected list" made up by unscrupulous tree sellers. Up to the present time from 100 to 150 varieties have been propagated, but of these many have already been abandoned and others are of too recent introduction to have demonstrated their value.

At present there are about 50 sorts of sufficient merit to make it possible to select varieties reasonably certain to succeed in almost any pecan-growing locality. The introduction of new varieties is no longer necessary or advisable unless they possess very evident superiority in productiveness, size, disease resistance, cracking quality, dessert quality, or other important characteristics, or proved adaptability to special conditions. Additional varieties of medium value only burden the lists and cause confusion. With the exception of the Havens, the varieties here described and illustrated are of special interest because of their having originated in sections to which the adaptability of few named sorts has yet been demonstrated.

BURKETT PECAN.<sup>1</sup>SYNONYM: *Labadie*.

The original tree of the Burkett pecan was first discovered by Mr. J. H. Burkett, of Clyde, Tex. It was a wild tree then standing in a crowded location near the banks of Battle Creek, 3 miles east of Putnam, Callahan County, Tex., on a farm owned at that time by Mr. Y. A. Orr. After observing this tree for three seasons Mr. Burkett became so favorably impressed with its bearing habit and the evident merits of the nut that on July 4, 1903, he inserted two buds from it in a pecan sprout grown from a stump cut two years before, which stood in the open some 300 yards from the parent tree and on land then owned by him. This budded tree made a rapid growth, and in 1904 it matured two nuts. From that year the annual crops

<sup>1</sup> The descriptions of pecan varieties which follow have been furnished by Mr. C. A. Reed, scientific assistant, Bureau of Plant Industry.



increased in size until 1910, when it yielded 10 pounds. The following year the crop fell to 6 pounds. In 1912 it again bore well, although trespassers gathered practically the entire crop, and the exact yield is therefore not known. The parent tree passed out of control of Mr. Burkett and was killed by being cut to the ground in the spring of 1912.

In an address on "New varieties of pecans," given by Mr. M. Falkner, of Waco, Tex., at a meeting of the Texas State Horticultural Society in July, 1911, this variety, on the basis of information received from different sources, was unwittingly reported under the names "Burkett" and "Labadie," the latter having been applied in honor of Mr. Victor H. Labadie, of Dallas, Tex., who had become interested in it. This address was subsequently published as a part of the report of that society.<sup>1</sup> This unintentional duplication soon became apparent and "Burkett" was recognized as the correct name of the variety by Reed in 1912.<sup>2</sup>

#### DESCRIPTION.

Size large, averaging from 50 to 55 nuts per pound; form roundish oblong, distinctly shouldered at apical end; base flattened; apex short; color light gray brown, with numerous black specks over entire surface and dark splashes near apex; shell moderately thin, though soft and breaking readily; partitions somewhat thick, corky; cracking quality good; kernel symmetrical, roundish oblong, broadly grooved, surface smooth; texture moderately firm; flavor sweet; quality very rich, oily. The nuts are uniform in size and the kernels plump, although not to such a degree as to interfere with the cracking quality.

The budded tree was described to Mr. Falkner in 1911 as then being "about 12 feet high, with a 6-inch diameter 3 feet above ground, and of symmetrical form." Mr. Burkett reports that the foliage of this tree is dense, coarse, and of a rich green color. He states that the variety is easy to propagate. The nuts<sup>1</sup> are said to form in large clusters.

Because of its good quality, ease of cracking, large size, and place of origin, this variety should be especially valuable for planting in northern and central Texas and places of similar climatic and soil conditions.

The specimens illustrated in Plate VIII were of the crop of 1911 from the budded tree and were supplied by Mr. Burkett.

<sup>1</sup> Proceedings of the Fourteenth Texas Farmers' Congress. Texas Department of Agriculture, Bulletin 22, 1911, p. 122.

<sup>2</sup> The Pecan. Bureau of Plant Industry, Bulletin 251, p. 47.

## MAJOR PECAN.

The parent tree of the Major pecan is located in a native pecan forest near the mouth of Green River, Henderson County, Ky. It is owned by Mrs. Laurie M. B. Major, of Henderson, in honor of whose late husband it was named. It appears to have attracted considerable local attention previous to 1907, when Mr. C. G. Taylor, of Princeton, Ind., sent specimens of the nuts to Mr. W. N. Roper, of Petersburg, Va. The evident merits of the nuts and the account of the tree so favorably impressed Mr. Roper and his partner, Mr. E. Gill Hinton, that the latter went to the original tree during the summer of 1908 for the purpose of obtaining scions, and from the scions then obtained the first nursery-grown trees of the variety were propagated. The variety was first described in the second edition of "The Pecan and Its Culture," by H. H. Hume, in 1910.

The actual bearing record of this tree has not been kept, but it is stated by persons in the locality of its origin that during recent years it has borne regularly and that frequently the crops have been approximately 100 pounds. It is a healthy tree  $2\frac{1}{2}$  feet in diameter at breast height and 59 feet to the first branch.

## DESCRIPTION.

Size somewhat below medium, averaging from 85 to 90 nuts per pound; form roundish oblong to oblong conic, tapering slightly at base; apex short, rather plainly grooved; color light brown with sparse markings toward apex; shell smooth, moderately thick, brittle, cracking readily; kernel roundish, oblong, plump, bright colored, and sufficiently broad grooved to release kernel readily; texture firm, crisp; flavor sweet, pleasant; quality excellent. In cracking quality and richness of kernel this nut compares favorably with any of the known sorts. These points, together with its reported productiveness and the latitude in which it originated, should commend it strongly for trial planting in the northern portions of the pecan area.

The specimens illustrated in Plate VIII were of the crop of 1911 and were obtained from the original tree by Mr. T. P. Littlepage, of Boonville, Ind.

## OWENS PECAN.

The original tree of the Owens pecan was grown from a nut purchased and planted in the spring of 1900 by Mr. F. M. Owens, upon whose plantation it now stands, near Gerald, Coahoma County, Miss. Mr. Owens purchased nuts for planting from the J. Steckler Seed Co., of New Orleans, and from Mr. S. H. James, of Mound, La.

Having made no attempt to keep the seedling trees from the two sources apart, he is now unable to determine from which source the seed came. The nut characters and the habit of the tree so much resemble the Frotscher, one of the varieties then being sold by the J. Steckler Seed Co., that it seems fair to assume that the Owens is a seedling of that variety.

The original tree was grown in a nursery row and subsequently removed to its present location. In 1907 it bore one nut. In 1908 the crop was an entire failure, but in 1909 it matured about 100 nuts, and in 1910 it had approximately 300 nuts. In 1911 it bore about 37 pounds, but in 1912 the crop was again very light. The nuts usually mature about September 20. This variety was first propagated in the spring of 1911, when Mr. Owens sent scions to two nurserymen in Louisiana for use in top working. Its name was suggested in March, 1911, by Mr. James, in honor of Mr. Owens.

#### DESCRIPTION.

Size large, varying from 55 to 80 nuts per pound, averaging from 60 to 65; form oblong, oval, slightly compressed, with tapering base and apex, often one sided; sutures quite distinct, somewhat ridged; color reddish gray-brown with broad reddish-black to black markings, mainly at apical end; shell thin; partitions fragile; cracking quality excellent; kernel somewhat shriveled, often lacking in plumpness; surface not always smooth; texture rather dry; flavor fairly good; quality good.

The parent tree is described by Mr. Owens as being about 40 feet tall, having a spread of 40 feet 4 inches, and as measuring 33 inches around the trunk at breast height. The foliage is dense, leaflets large, rather coarse, and of a dark-green color. The old wood is of a slaty-gray color and the new growth an olive green. On the new wood the dots are narrow, long, and quite numerous.

The fact that the place of origin of this variety is near the northern limit of the region known to be adapted to the southern varieties combines with the good size, ease of cracking, and earliness of maturing of the nuts to make this variety well worthy of trial in northern Mississippi, southern Arkansas, southern Oklahoma, and sections of similar soil and climatic conditions.

The specimens illustrated in Plate VIII are from the original tree, crop of 1911, and were supplied by Mr. Owens.

#### WARRICK PECAN.

The original tree of the Warrick pecan stands in a native forest in Warrick County, Ind. It is located on property near Pigeon Creek, and is now owned by Mr. C. F. Brown, of Rockport, Ind.

It was first called to public attention at Mount Vernon, Ind., when, in December, 1909, it was awarded the first premium for seedling pecans by the Southern Indiana Pecan Association. It was named by Mr. T. P. Littlepage, of Boonville, Ind., in the fall of 1910, when he visited the tree for the purpose of obtaining nut specimens and the bearing record of the tree. Its propagation was begun by Mr. Littlepage in the spring of 1911.

Little is known of the exact bearing record of this tree, as until recent years the nuts have been harvested annually by nut gatherers who made no attempt to keep separate the nuts from individual trees, but it is locally reported to have been a heavy and regular bearer.

#### DESCRIPTION

Size rather below medium, averaging from 75 to 80 nuts per pound; form oblong, with rather short apex but longer base; color yellowish brown, bright, with irregular dark splashes; shell rather hard, moderately thin, brittle; cracking quality good; kernel rather dark straw color, usually plump, though occasionally somewhat defective; flavor pleasant; quality good.

The reported heavy-bearing habits, the attractive appearance of the nuts, the good quality of its kernels, and its place of origin make this variety of distinct promise to pecan planters in the more northern districts suited to the species.

The specimens illustrated in Plate VIII were obtained from the original tree in 1911 by Mr. J. Ford Wilkinson, of Rockport, Ind.

#### HAVENS PECAN.

The original tree of the Havens pecan stands on the residence grounds of Mrs. Kate V. Havens, widow of the late Walter Havens, of West Pascagoula, Miss. It was grown from a nut of the Russell variety, secured and planted in the spot where the tree now stands by Mr. Havens about 1894. It began bearing when 5 years of age; and while no exact record of its annual crops has been kept, it is said<sup>1</sup> to be much like the parent variety in its bearing habit.

The apparent merits of this nut were such that it was named in honor of the originator in 1902, and in 1903 or 1904 its propagation was begun by Mr. Theodore Bechtel, of Ocean Springs, Miss. It has since been quite widely disseminated.

#### DESCRIPTION.

Size medium to large, averaging from about 65 to 70 nuts per pound; form oblong, somewhat ovate, compressed, with sharp base

<sup>1</sup> Letter from Mrs. Havens, July, 1912.

and blunt apex; color dark brown splashed toward apex and dotted on flattened sides with purplish black markings; shell very thin, brittle; partitions thin and fragile; cracking quality excellent; kernel bright brown, smooth, usually plump, narrowly grooved; texture firm, fine grained; flavor pleasant; quality good.

In form and habit of growth the Havens tree resembles its parent, although it is rather more symmetrical than that variety. Its bearing habits are also very much the same. Mrs. Havens reports that this variety is a vigorous grower and a heavy annual bearer, but says that the nuts from the parent tree are rather inclined to be defective in plumpness. Mr. F. H. Lewis, of Pascagoula, Miss., who has had trees in bearing for some years, reports little trouble in that respect. In his opinion its productiveness, thinness of shell, and excellent cracking qualities make it one of the most promising varieties for planting in the Gulf coast region at the present time. The specimens examined at the Department of Agriculture during the past several years have not shown an objectionable number of defective kernels. Its known habits of bearing, together with its resistance thus far to fungous diseases and its excellent cracking qualities, should commend it to planters in sections to which the Russell variety is adapted.

The specimens illustrated in Plate VIII were of the crop of 1911 and were grown by Mr. F. H. Lewis, of Pascagoula, Miss.

# OUR MEADOW LARKS IN RELATION TO AGRICULTURE.

(*Sturnella magna* and *Sturnella neglecta*.)

By F. E. L. BEAL,

Assistant in Charge of Economic Ornithology, Biological Survey.

## INTRODUCTION.

Belonging to the same family as the orioles and blackbirds, our meadow larks occupy a somewhat peculiar position. Living in grassy fields and meadows, they are common over much of the United States and in some districts are very numerous. Though not usually classed among songsters, meadow larks have a pleasant song, are of decidedly insectivorous habits, and in certain States are classed among game birds and are allowed to be shot during the open season. In some districts they are reported to destroy considerable quantities of grain, and their destructiveness in this respect is given as one of the reasons why they should be removed from the class of protected birds and allowed to be shot for sport and food. Thus the economic position of the meadow lark is of considerable importance and the present paper is intended as a contribution to the subject.

## DISTRIBUTION.

Two species of meadow larks inhabit North America. The first (*Sturnella magna*), with its several subspecies, occupies the eastern part of the country as far west as western Iowa and eastern Kansas and from the interior of British America to the Gulf. The other species (*Sturnella neglecta*) inhabits the Pacific coast region and extends eastward to meet, and in some places overlap, the range of the first. In winter the eastern form moves to the south, but a limited number remain as far north as southern Illinois. The western form winters somewhat farther north. The two species are so nearly alike in plumage that only an expert can tell them apart. Their songs, however, are very different. Meadow larks are not partial to a timbered country, though they appreciate an occasional tree as a lookout, but a fence will answer for this purpose, while a telegraph wire or pole is better than either. Level, or somewhat undulating land, covered with grass or weeds and having plenty of water at hand, furnishes the conditions best suited to the meadow lark's taste.

## FOOD HABITS.

In the matter of food the two species are scarcely distinguishable. Being of terrestrial habits, the greater part of their food is gathered from the ground and so naturally consists of ground-living insects, grain and other seeds, and a little fruit.

In southern California the meadow lark is accused of eating peas to an injurious extent, especially early peas. The damage is greatest when peas are grown in small lots, and some years the losses are less than others. Mr. J. B. Handy, of Orange, Cal., writing to Mr. Lee Chambers, of Santa Monica, Cal., under date of November 17, 1908, says:

If a farmer has a half acre of early peas the meadow lark will harvest most of his crop if he does not stand guard with a shotgun and do what he can to prevent their destructive beaks from tearing open the pea pods.

In and about Modesto, Cal., this bird is accused of pulling up sprouting grain and eating it to a harmful extent. The author interviewed a number of grain growers in that vicinity and obtained some very decided testimony. The bird is said to get the kernels by boring a hole down beside the shoot, usually causing the sprout to die. Mr. J. S. Morton stated that he had seen limited areas where the crop had been reduced 50 per cent by the meadow lark. In consequence he claimed that the bird was a great nuisance and should be shot on sight. Mr. Willis Bloodsaw, who farms 4,500 acres, says that although meadow larks pull up some grain he never saw a field seriously injured by them. Mr. Charles Swan, who farms a large area, has never suffered any appreciable loss by meadow larks. Mr. Johnson, another grain raiser, stated that meadow larks do him no harm whatever. Mr. J. M. Bomberger said that on his oat field the meadow larks pulled up a considerable number of the blades, but there was a good crop in spite of this, and that in his opinion the birds did more good than harm, and farmers would be badly off without them. Mr. W. R. High, banker, was formerly a wheat raiser. He said that he often found the meadow lark very destructive to grain and that in some years the birds were worse than in others. He thinks meadow larks are a constant menace to the grain crop if they are at all numerous, and said that formerly he was forced to poison them by thousands.

The reader will notice the lack of agreement among the above statements and will probably infer that the causes which make the meadow larks a nuisance on one ranch and a blessing on a neighboring one are narrowly local.

In Tennessee the eastern species (*magna*) has been accused of eating clover seed, but this was probably an error of observation, as

examination of many stomachs, including those sent by the complainant, fail to show clover seed to any harmful extent.

Among the stomachs examined were several taken when the ground was covered with snow, but in spite of this the birds succeeded in filling themselves with food, a large percentage of which consisted of insects. This illustrates the bird's ability to procure its natural sustenance under what would appear to be trying circumstances. A few individuals of the eastern species sometimes winter far north of their usual winter range, and in spite of snow and cold they manage to obtain food and come through the winter safely. This is in part due to the fact that for a time they can subsist on a purely vegetable diet, such as seeds, which are usually obtained more easily than insects in the winter season.

In the laboratory investigation of the food of the meadow larks 1,514 stomachs were examined, of which 312 were known to be of the species *neglecta*. Of the remaining 1,202 the great majority were *magna*, but as many of them had been collected before the two species were separated it is probable that some of them were really *neglecta*. Since there is so little difference in the food habits of the two species and some of the stomachs are in doubt, the two species are here treated as one, as they really are from an economic standpoint. They were collected in 36 States, the District of Columbia, and Canada, and in every month of the year. The food was found to consist of 74.22 per cent of animal matter to 25.78 of vegetable.

#### ANIMAL FOOD.

Of the animal food 25.46 per cent is composed of the remains of beetles, and of these 12.10 per cent are useful species, mostly Carabidæ or ground beetles. Weevils, or snout beetles, amount to 4.94 per cent, and all others to 8.44 per cent. The number of ground beetles eaten is more than is taken by most birds, but these insects are so terrestrial that they are found by the meadow larks probably oftener than any other insect, and as they live through the winter to a great extent they are obtainable at all times when the weather is mild enough for them to be out. More are eaten in spring and early summer before the grasshopper season is on.

Among the beetles found in the stomachs of the meadow lark were several specimens of the adult insects of the southern corn root-worm (*Diabrotica 12-punctata*). In the Southern States and as far north as Illinois this insect is more or less of a pest to young corn and often causes great damage. The eggs are laid in the ground near the young corn plants and when hatched the young bore at once into the plants. In many cases the destruction amounts to 50 per cent; in southern Illinois and farther south it is often worse. The



same beetle has been known for a long time as an enemy of cucumber and melon vines and other cultivated plants.

*Agonoderus pallipes* is a small carnivorous beetle that, as far is known to the writer, has never yet received a common name. This insect seems to have forgotten its natural food habits so far as to eat and spoil seed corn in the ground. Several of these beetles were found in the meadow lark's diet.

To the genus *Lachnosterna* and several closely allied ones belong the numerous white grubs so often found in cultivated land. They are among the worst enemies to many cultivated crops, notably grasses and grains, and to a less extent strawberries and garden vegetables. While in the larval stage they eat the roots of these plants, and being large, one individual will destroy several plants. In the adult stage they feed upon the foliage of trees and other plants, and in this way continue the damage which they began in the earlier form. Forty-two individuals of different species of this genus were found in the stomachs of meadow larks and there were probably many more which were past recognition. As these enemies of husbandry are not easily destroyed by man, it is obviously wise to encourage their natural enemies.

Among the weevils the most important economically are the cotton-boll weevil (*Anthonomus grandis*) and the recently introduced alfalfa weevil (*Phytonomus posticus*) of Utah. Several hundred meadow larks were taken in the cotton-growing region, and the boll weevil was found in 25 stomachs of *magna* and 16 of *neglecta*. Of the former one stomach contained 27 individuals. Of 25 stomachs of *neglecta* taken in the alfalfa fields of Utah in May, June, and July, 1911, 15 contained the alfalfa weevil in either the adult or larval stage. In one stomach 23 adults were found, in another 70 larvæ and 32 adults, still another had 40 larvæ and 10 adults, and a fourth contained 100 larvæ and 4 adults. In all these cases the number of larvæ is probably underestimated, as they were badly broken. Hymenoptera are eaten by the meadow lark but sparingly and are represented mostly by ants, which amount to only 2.79 per cent. Bees and wasps amount to about half as much. Hemiptera (bugs) also are not extensively eaten and aggregate but 3.43 per cent. They belong to 8 families, but the Pentatomidæ, or stinkbugs, far outnumber all the others and were found in 166 stomachs. A few scales (*Eulecanium*) occurred in one stomach.

Diptera are conspicuous by reason of their absence from the food of the meadow lark. They aggregate for the year only 0.36 per cent. Lepidoptera in the shape of caterpillars hold a prominent position in the food from February to June, inclusive. They attain their maximum of 24.49 per cent in May and for the year average 10.54 per cent. A great many of these caterpillars belong to that group

commonly known as cutworms (*Noctuidæ*), species that for the most part live in the ground and destroy young plants, such as garden vegetables. The only insects of this order specifically identified were a few army worms (*Leucania unipuncta*) found in one stomach. Orthoptera, represented by grasshoppers and some crickets, were eaten in every month and are evidently the favorite food of meadow larks. The average for the year is 26.08 per cent, or more than one-fourth of the food, and for each of the three months of August, September, and October they constitute more than one-half of the total diet. They form a good percentage of the food in every month, and in March, the month of least consumption, they still amount to nearly 5 per cent, or more than all the grains except corn. They were found in 778 stomachs, or nearly 53 per cent of the whole number, and several stomachs contained no other food.

A few spiders, myriapods, snails, and an occasional lizard make up the remainder of the animal food, 4.31 per cent.

#### VEGETABLE FOOD.

The vegetable food of the meadow lark consists principally of fruit and seeds, including grains. It amounts to 25.78 per cent, or not quite so much as grasshoppers alone. Of the fruit, 13 species of berries were identified by their seeds, and of these 2 are or may be domestic. They were blackberries or raspberries found in 13 stomachs and strawberries in 1. All the rest are wild fruits useless to man. Corn is the principal grain and amounts to 9.07 per cent, nearly twice as much as all the other grains together. The average for oats is 2.81 per cent, for wheat 1.54, and for all other grains except corn 0.28 per cent. The month of greatest consumption of oats is October, with 7.99 per cent; for wheat December is at the head, with 4.53 per cent, and January nearly the same. Considering the small amount of grain eaten by individual birds, it is evident that to do much damage meadow larks must visit the fields in immense numbers. Clover seed was found in 14 stomachs, but only one or two seeds in each. In considering the damage done to grain by the meadow lark it would be well to bear in mind that the average monthly destruction of grasshoppers is more than double that of all the grains put together. Weed seed amounts to 7.97 per cent of the food and is eaten to some extent in every month, but mostly in the colder months. While it amounts to over 20 per cent of the food in November, December, and February, it falls a little short of 8 per cent in January. This is perhaps accounted for by the fact that most of the stomachs collected in that month were taken in Florida, Louisiana, and Texas, where insects are accessible all winter. February is the month of maximum consumption, with 24.38

per cent, and March shows 11.77 per cent, after which but little of this item is eaten till November. A few miscellaneous items of vegetation and some rubbish make up the rest of the vegetable food, 3.49 per cent.

#### SUMMARY.

In a résumé of the food of the meadow lark one is impressed with the fact that more than five-sixths of the animal food is contained under the three items of beetles, caterpillars, and grasshoppers. Ants, so often eaten by ground-feeding birds, do not appear to appeal to the meadow lark, while caterpillars and grasshoppers are apparently eaten whenever found. In the matter of vegetable food no such special preference is shown, though corn and weed seeds are evidently the favorites. Corn being taken only in the late fall and winter months, is probably mostly waste grain, while the other grains are eaten so sparingly as to indicate that they are not preferred food, so far at least as the eastern species is concerned, but the western form takes the other grains, especially oats, much more freely. In the stomachs taken in California oats begin to appear in reasonable quantities (11.57 per cent) in September and increase to a maximum of 53.14 per cent in January. This grain is probably taken from the newly sown fields both before and after germination. The quantity drops very suddenly in the months after January and scarcely appears at all in spring and summer. When the birds are numerous it is quite conceivable that they may do considerable damage to grainfields if over half of their daily food consists of oats. The record, however, is not very reliable, as only seven stomachs were taken in California in January, and a greater number might give a different result. In view of the destruction of caterpillars and grasshoppers by the meadow lark, it behooves the farmer to be cautious in classing the bird as a nuisance because it damages grain to some extent. It may well be questioned if the insects eaten by the bird might not, if left to live out their natural lives, do much more damage to the grain than do the birds. It is difficult, if not impossible, to strike a balance between products damaged and insects and vegetable pests destroyed, but in estimating the economic value of the meadow lark it is significant that the total of grain in the meadow lark's diet is only 12.72 per cent of the whole, while noxious insects and weed seeds amount to 64.06 per cent.<sup>1</sup>

---

<sup>1</sup> An investigation of the meadow lark's food is now being carried on in California by Mr. Harold C. Bryant, of the California State Fish and Game Commission. In a report upon the contents of 54 stomachs Mr. Bryant has drawn conclusions practically agreeing with those given above. Much more material than has hitherto been examined is needed to settle the question satisfactorily.

# THE HANDLING OF DRESSED POULTRY A THOUSAND MILES FROM THE MARKET.

By M. E. PENNINGTON,  
*Food Research Laboratory, Bureau of Chemistry*

## HISTORICAL INTRODUCTION

Our grandmothers tell us of the time when the chore boy, wielding the farm ax, decapitated the chickens that had been hatched on the home farm and fed and cared for by the women of the family to be utilized for the feeding of the farm people. Our mothers tell us of the days when the family supply of fresh produce was purchased from the farmer, who brought butter, eggs, poultry, and fresh vegetables into the city from his near-by farm. But now we see the chickens that we are to eat on either the Atlantic or Pacific coast roaming the cornfields of Kansas and Iowa or the wheat fields of Minnesota or the Dakotas, or clustering around the mountain cottages in Tennessee and Kentucky; and instead of the rumble of the farm wagon bringing them to the family, we hear the patient, continuous chug-chug of the long freight train as it winds over the prairie and climbs the mountains on its way to the hungry millions who live far from the great producing section of that almost ubiquitous bird—the common barnyard fowl.

Formerly chickens were killed to-day and eaten to-morrow, because decay could not be checked for any length of time. Then, as the farms were pushed away from the edges of the growing cities, crushed ice was used to preserve the dressed birds until they could reach the consumer, a matter of a week, perhaps. Plate IX shows a barrel of ice-packed poultry, chickens and ice layer by layer, and a big lump of ice on top. The soaking of the birds in the melted ice, the dirty heads and feet, and the gradual dissolving out of the soluble parts of the flesh caused a loss in eating quality and induced decay.

The people increased in the cities faster, however, than the chickens multiplied on the near-by farms. The hauls soon became too long for farm wagons, and then the railway was called into service. Each year for 20 years or more the railroads have been carrying to eastern and western cities dressed poultry from a wider and wider radius. Texas turkeys and Oklahoma chickens are sent to New York and San Francisco, and, such are the wonders of the modern methods of handling perishable foodstuffs, they usually reach these distant centers in better condition than did the ice-packed chickens years ago

after traveling only a hundred miles or so. In these days of food shortage and enforced conservation of foodstuffs it is well to know something of the means by which distant sources of production are made available to the nation, and such delicate commodities as dressed poultry delivered in good order to a consumer living a thousand miles or more from the place where the chickens were raised and killed.

#### PREPARATION FOR KILLING.

Good handling of dressed poultry necessitates facilities which can not be maintained by the individual farmer. Dressed poultry is now a business by itself, and a great industry has grown up to attend to this work. Therefore, when the farmer's flock has reached a marketable stage he sells it to the poultry packer, or to his agent, and the birds reach the packing house located in the producing section in great wagonloads, as shown in Plate X, or by the carload, Plate XI. The latter illustration shows the type of "live poultry car" which is now being used when the birds must be carried alive for more than a day. Both wagon and car are being unloaded at establishments of poultry dressers.

The fowls are generally hungry and thirsty and are always nervous and tired; hence they are not in condition to be killed. Many of them are thin, because comparatively few farmers feed their poultry enough to fatten them. The poultry packers have established feeding stations where from 10,000 to 30,000 birds, housed in specially constructed feeding batteries, are given clean grain mixed with buttermilk for from 7 to 14 days. The 7-day feeding causes a great improvement in the flavor and tenderness of the flesh; feeding for two weeks causes young birds to double in weight if they are vigorous and of a desirable breed for food purposes.

Photographs of feeding stations and the batteries in which the birds are kept are shown in Plate XII. Note how light and airy are the stations. They are also clean, because dirt prevents the birds from gaining weight. What progress this wholesale feeding represents is better understood when the juicy, milk-fed bird is tasted and compared with the "ranger" chicken that forages far and near for a living and eats from the dunghill a large part of the time. The new system of crate fattening is an outgrowth of an old custom on many farms of feeding milk and clean grain for several days before killing.

After the feeding period is over the birds should be starved for 24 hours, having a plentiful supply of clean water only. This practice results in almost completely emptying the intestinal tract of foods in process of digestion and of waste products to be thrown off, and has been found to be far better than the practice of eviscerating when the bird is killed.

It may be said in passing that the viscera should not be removed until the bird is about to be cooked. A habit has developed, especially in cities, of permitting the butcher to draw the birds before sending them to the consumer. If the housewife had the drawing done in her own kitchen the bird would be in a more sanitary condition and she would frequently find evidences of unfitness for food that disappear with the removal of the entrails.

## PROCESSES OF KILLING AND PICKING.

When farmers prepared the poultry for market the process of killing and picking was an individual matter. Some simply chopped off the head, dipped the carcass in water heated to the steaming point to loosen the feathers, rubbed these off, and, if the weather was cool, kept the bird out of doors or in a well-ventilated room until it was taken to market. Poultry so prepared has a greatly shortened keeping time, and the eating quality is lowered even before decay has begun, because the desirable "ripening" that does so much to improve flesh does not occur.

The undesirable methods used heretofore are many and various, but they are being so rapidly replaced by better methods that it is scarcely worth while to give space to their description. Rather let us pass at once to what are now the best procedures known for the dressing of poultry to preserve quality and prevent decay, for these methods only can be used if the bird is to travel long distances and be kept fresh for from two to three weeks before it reaches the table of the consumer.

Plate XIII shows the dressing of poultry in a house west of the Mississippi River. The output is marketed in New York City. In this house men kill the birds by cutting the jugular vein with a slender, straight-edged knife, especially constructed for the purpose.<sup>1</sup> Then that portion of the brain tissue which controls the muscles holding the feathers in place is destroyed by a thrust of the same knife, and the feathers are so loosened that they are easily pulled out. The cutting of the blood vessels in the proper way permits the blood to drain out of the carcass until it is practically blood free.<sup>2</sup> This is essential, if the bird is to keep well, and is a part of the process of dressing that is too often faulty. In order to accomplish this bleeding the vessels must not only be cut properly, but the bird must be held head down while removing the feathers. The scheme used in the killing room shown in Plate XIII permits this, prevents the feathers from being contaminated with blood, and enables the killer to handle

<sup>1</sup> A Knife for Killing Poultry. Bureau of Chemistry, U. S. Dept. of Agriculture, 1910.

<sup>2</sup> How to Kill and Bleed Market Poultry. Circular No. 61, Bureau of Chemistry, U. S. Dept. of Agriculture, 1910.

the bird very quickly, less than 2 minutes being required for killing and the removal of all except the fine down and pin feathers. When the feathers have been removed, the bird, still hung by the feet, is taken by women and "pinned" or "tipped," as the western phrase goes; that is, the fine down and the close-growing feathers are picked off one by one.

The system of killing shown in Plate XIII is known as the "frame method" and has resulted from a selection and combination of the best features of the "string" and "bench" systems. String killing has been most commonly used and is illustrated in Plate XIV, figure 1. The bird is hung by twisting a cord around the feet, "bled" and "brained," and the feathers removed while it hangs head down. A vessel fastened to the head of the bird catches the blood. "Bench killing" is shown in Plate XIV, figure 2. Here the head of the chicken is held by means of a hook, the legs by the hand of the operator. After killing, the feathers are removed, as shown in the illustration.

"Frame killing" keeps the bird upright, prevents its coming in contact with rough or soiled surfaces as with the string method, and holds the bird even more firmly than does the bench method, because the feet, as well as the head, are supported.

Cleanliness of handling is further emphasized by the system of pinning while the birds are hung on shackles, as is shown in Plate XV, figure 1. This scheme permits of quick, good work and is vastly superior to the old "lap" method, which is shown in Plate XV, figure 2. Pinning by the lap method means that the skin of the bird is constantly being rubbed over dirty, bloody surfaces and that it is frequently held by the neck, which prevents the draining out of the last portions of the blood.

Cleanliness being one of the watchwords of modern poultry dressing, the heads must be freed from blood and neatly wrapped in paper, and the feet must be scrubbed if they are dirty. This is generally done just before the birds are sent to the chill room.

#### CHILLING.

The up-to-date packer no longer uses ice to remove the animal heat. He uses mechanical refrigeration and provides clean, insulated rooms in which a temperature of about 32° F. is constantly maintained. The chickens are hung by the feet on racks<sup>1</sup> made entirely of metal, such as are shown in Plate XVI. This illustration shows, also, how a number of these racks stand in the chill room while the poultry is cooling, and the arrangement on the walls of the pipes carrying the cold brine on which the refrigeration depends. The four topmost pipes are doing the work, as is shown by the heavy covering of frost from the condensation of the moisture in the air.

<sup>1</sup> Public Patent No. 1,020,575, M. E. Pennington and H. C. Pierce.

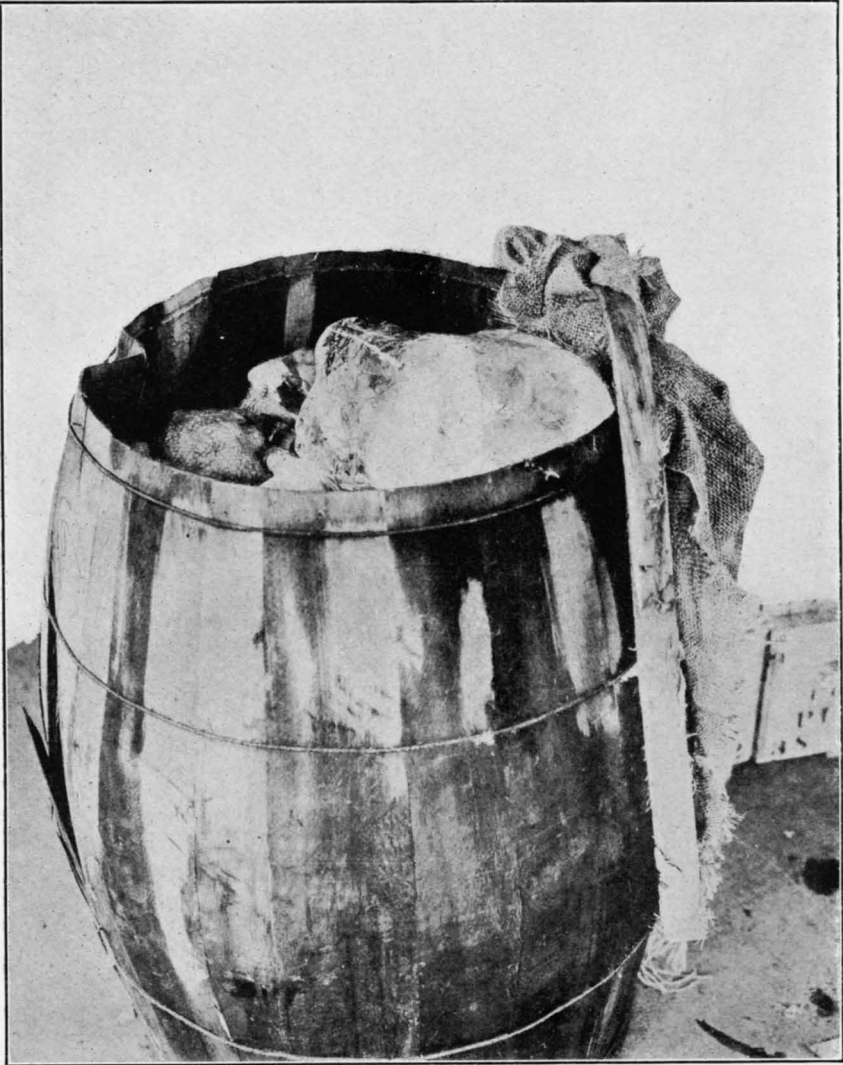

POULTRY PACKED IN A BARREL WITH ICE.





A WAGONLOAD OF LIVE POULTRY COMING TO A WESTERN PACKING HOUSE.

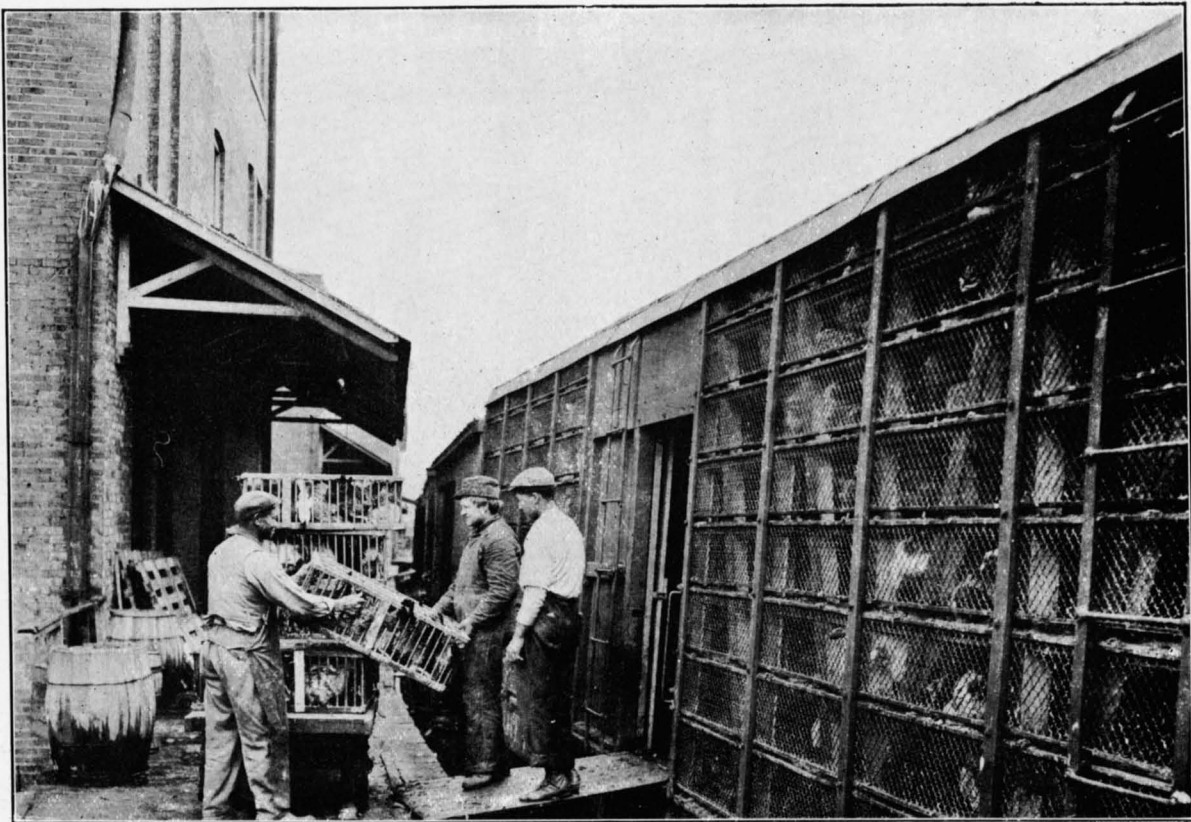

LIVE POULTRY BY THE CARLOAD.



FIG. 1.—A LARGE FEEDING STATION WELL LIGHTED AND VENTILATED.



FIG. 2.—A FEEDING STATION 300 FEET LONG, ACCOMMODATING 30,000 BIRDS.



FIG. 3.—AT FEEDING TIME IN THE FATTENING STATION.



A POULTRY-KILLING ROOM.



FIG. 1.—"STRING" KILLING AND PICKING.



FIG. 2.—"BENCH" KILLING AND PICKING.

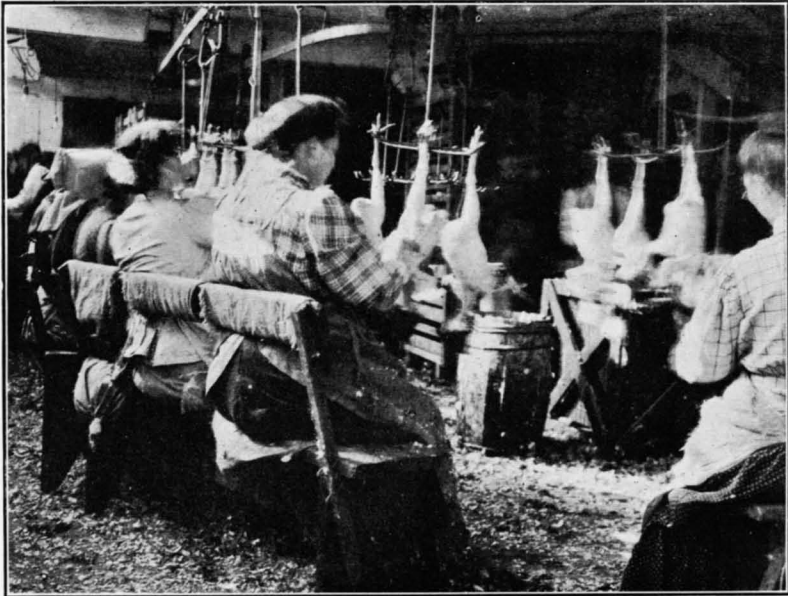

FIG. 1.—REMOVING SMALL FEATHERS WHILE THE BIRDS HANG BY THE FEET.

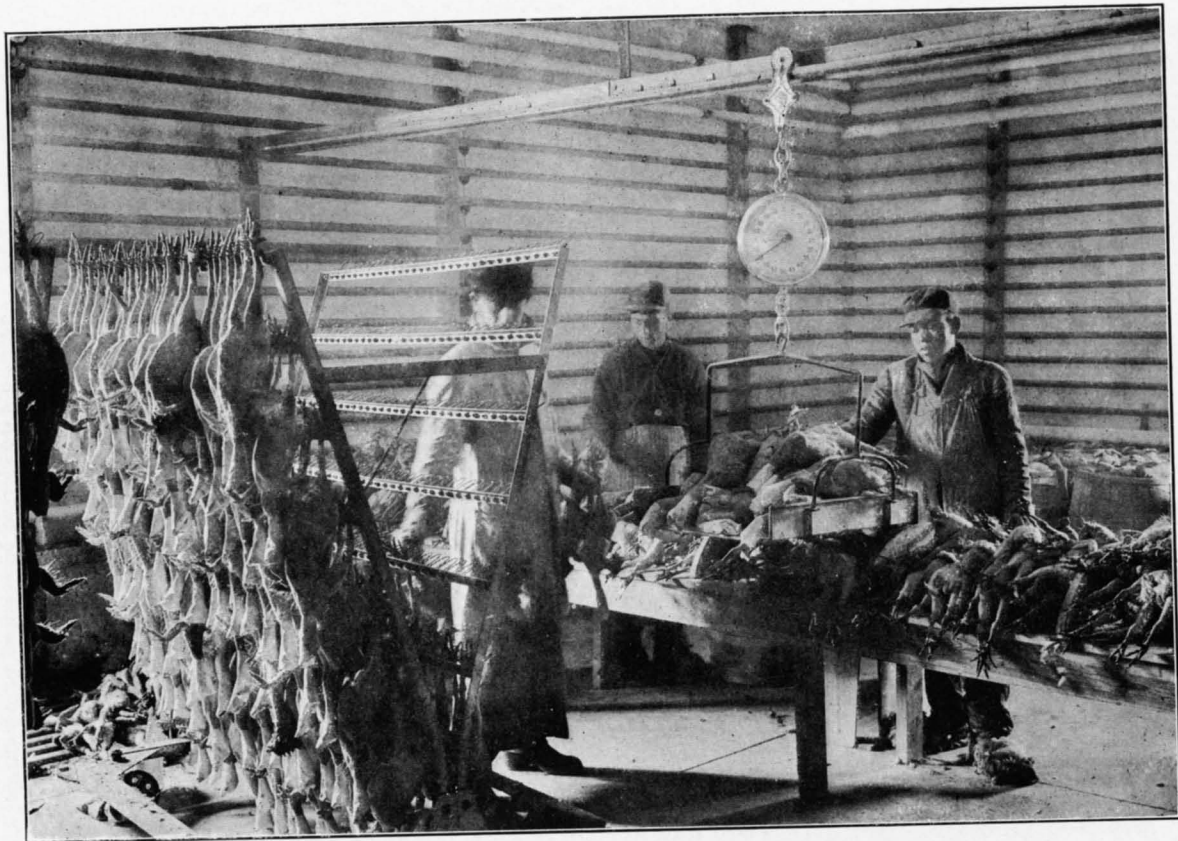

FIG. 2.—HOLDING BIRDS ON THE LAP TO REMOVE SMALL FEATHERS.





METAL POULTRY-CHILLING RACKS, STANDING IN A MECHANICALLY COOLED CHILL ROOM.



GRADING FROM A HANGING RACK IN A NATURALLY LIGHTED MECHANICALLY REFRIGERATED PACKING ROOM.





BOX-PACKED POULTRY READY FOR SHIPMENT



DRESSED POULTRY PACKED IN CARTONS.



PUTTING ICE AND SALT INTO REFRIGERATOR CAR.

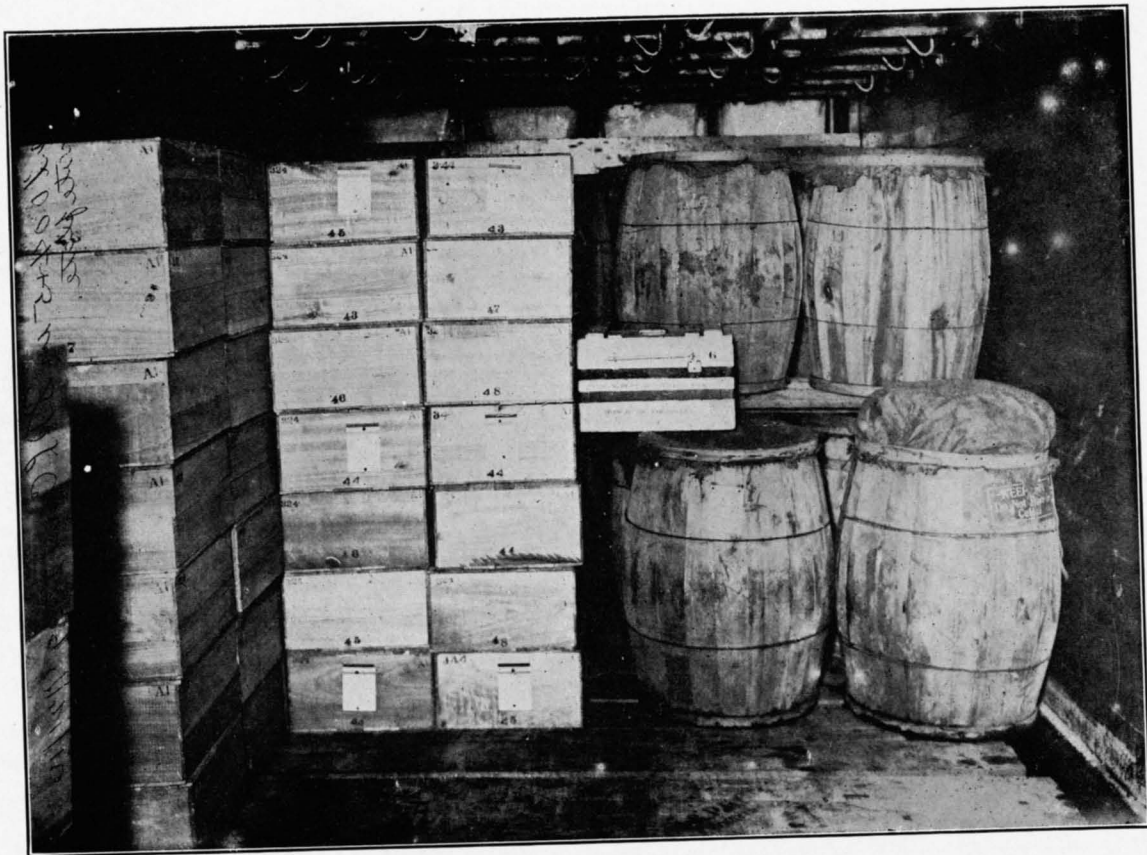

A REFRIGERATOR CAR LOADED WITH POULTRY IN BOXES AND BARRELS.

Low temperature, as we know from household practices, is used to inhibit decay, which it does by slowing bacterial growth and enzym action. When chickens are alive their temperature is 103° F. This must be reduced to 32° F. or less before the birds can be packed for long hauls in refrigerator cars.

The time required to chill the fowl is usually about 24 hours, and the packer must be sure that the viscera, as well as the skin and flesh, are free from heat before the birds leave the chill room. It is the failure to observe this requirement that is responsible for much of the bad-conditioned poultry in our markets. The range of temperature permitted, too, is small. Below 30° F. the flesh is frosted; above 35° F. decay proceeds too rapidly to permit of long hauls to distant markets and a routine of marketing such as our urban life now requires. Of course, the birds can be frozen hard after they are chilled, and so shipped, and this is a very excellent plan, especially if the haul is across a hot country.

#### GRADING AND PACKING.

Having removed the natural heat from the dressed fowls, the next step in their preparation is to grade and pack in suitable containers for shipment. This operation should be performed in a room having a temperature of 30° F. and in this room the packed boxes may remain for several days while awaiting shipment.

No longer does the packer thrust old cocks, broiling chickens, and fowls indiscriminately into the big sugar barrel, pressing down the birds in his endeavor to pack tightly and so bruising flesh and tearing skins. Such a procedure prevents good keeping; therefore the shipper, far from his market, must not only avoid it but he must use a package that allows the birds to stay in good condition the maximum length of time. With this end in view, as well as to enable his customers to see at a glance the quality of his product, he has adopted wooden boxes, holding only 12 birds each. He also takes care that each bird of the 12 is an exact match for the other 11, both in weight and quality, and when he has a brand on the box and a reputation in the market, he even matches the color of the skins, that the package may present an attractive appearance. Such exactness involves experience and knowledge in grading the birds, and is by no means a simple operation. Plate XVII shows the interior of a packing room with graders and packers at work. Natural light falls on the rack from which the birds are being removed; each dozen as selected are weighed on the track scale and the weight stamped on the box into which the packer puts them. The boxes are lined with parchment paper to protect the skins and to prevent evaporation, and sometimes, especially if long storage is contemplated, each bird is separately wrapped.

Plate XVIII shows the appearance of these boxes of chickens. Broilers are breast up, and there is but one layer in the box; roasters and fowls are packed on their sides, and two layers are used. The boxes of broilers weigh from 15 to 24 pounds; roasters and fowls may run 60 pounds to the box. The ordinary barrel of poultry weighs 250 pounds or more. When one considers the delicate character of the skin and flesh of a chicken and the pressure that the poultry in a heavy package exerts upon itself, it is easy to see what advantages in the way of good carrying apply to the small box.

For very high-grade poultry the carton holding one roasting or two broiling chickens is being used to a limited degree (Pl. XIX). Like all individual wrappers put on at the source of production, it tends to keep the bird clean and sound skinned. It also insures to the housewife a package that has not been mauled by prospective customers nor soaked in water by the retailer to freshen up a dried-out bird, or perhaps to remove the odors of beginning decay. When high-grade poultry is to be kept from the season of production to the season of scarcity, as is necessary to feed this great country, the carton pack is highly desirable. The drying out of the flesh in the low temperatures of the cold store is very largely prevented and, what is even more desirable, the unbroken package can be sent hard frozen to the consumer. As the consumer becomes better informed on the subject of food supplies and their handling the packers will mark the cartons with the date of killing, as well as the brand of goods. Thus the purchaser will see that the bird has been killed during the season when the quality is highest—broilers before December and roasters between September and January—and that they have not been held in storage more than 12 months. The packer of high-class goods is now more than willing to put such information on his labels; the warehouseman desires it; the wholesaler wants such information; but the retailer can not risk giving the true story to the consumer because the prevailing ignorance would translate the truth into undesirability, and the purchaser would go elsewhere to purchase the same grade of goods, but accompanied by the verbal statement of "strictly fresh and nearby." The consumer does not realize when he clamors for true labels on foodstuffs that his own ignorance and prejudice are the greatest bars to the obtaining of his wishes.

#### SHIPPING METHODS.

But to return to the boxed poultry that we left in the refrigerated packing room waiting for its long journey to the consumer. How must that journey be made to insure good order on arrival? The answer used to be "speed," because the time that the produce would keep was so short under even the best of prevailing conditions that the whole course of marketing must needs be rushed. Now the

reply is, good handling and refrigeration, from start to finish; refrigeration evenly and constantly maintained, because cold is a great discourager of those all-pervading and ever wide-awake forms of plant life, bacteria and molds, without which we do not have decay.

To maintain refrigeration between the far-distant source of supply and the consuming center, we have developed a system of refrigerated carriers in connection with our railroads, and we are as dependent upon them for our food supplies as is England upon her ships. The traveling public everywhere is familiar with the appearance of the outside of the freight car which bears the word "refrigerator," as well as the initials of its line, but few of the many thousands who depend on those cars for their daily supply of foodstuffs know how they are constructed and made efficient for the work which they are to do.

Ice is used to produce low temperatures, and when below 40° F. is required, salt is mixed with the crushed ice. A compartment is built across each end of the car to hold the ice, and openings above and below, into the body of the car, permit circulation and consequent cooling of the air of the car. Plate XX shows the procedure of icing and salting. Rock salt is contained in the barrel which lies on the roof of the car. The hatches through which the ice and salt are put into the bunkers are also shown. In some places ice crushers are used instead of man power, which greatly hastens the icing process.

In order to keep the heat of the atmosphere from penetrating the car and so disseminating the cold produced by the refrigerant, insulation must be used in its construction. The modern refrigerator car is rapidly becoming a chill room on wheels, and it must be that if it is to serve the public to its satisfaction and to the financial profit of the railroads as well. During the long hauls in the United States the same car, with its unbroken load, must traverse the heat of deserts and the cold of high mountains, or go from the warm southland to Alaskan snows. It may be that the load carried must not vary in temperature more than 5° F., in which case ice is used in some parts of the journey and stoves in others.

Our chickens, however, seldom become too cold. It is heat that we must guard against when they are shipped; therefore the careful packer will ask the railroad to set the refrigerator car on his siding at least 24 hours before he expects to load, for no packer who works to prevent decay ever loads his poultry in a car having a high temperature or hauls chilled goods in wagons. Then he will examine the car to see that when the doors are closed not a ray of light enters, because that would mean inefficiency of insulation. He looks also to see that drain pipes are working and the general repair good, and, finally, after the car has been iced and

salted for at least 24 hours, he takes the temperature about 4 feet from the floor midway between the doors. If it is below 40° F., he may load his chilled birds with safety. Plate XXI shows the loading of a car with mixed boxes and barrels of poultry. The packages bearing tags are to be examined by the United States Department of Agriculture when the goods reach their destination and their condition noted. The small iron-bound chest contains a thermograph which registers the temperature of the car during transit. One tagged barrel contains dry-packed, the other ice-packed poultry. The latter is the barrel having a big lump of ice under the burlap covering. This experimental shipment was made to determine the relative keeping time of wet and dry packed birds and also to study the question of the height of the load in the car. The car shown in the photograph is loaded too high. About 4 feet is much better. A great many experimental shipments of poultry have been made by the Food Research Laboratory to learn the best available way to conduct every phase of the handling, and it is on the basis of this experimental work that the statements in the present article are founded.

The loading of a car containing 20,000 pounds of poultry—that is, the car lot of the West—can be accomplished in 30 minutes if the work is well planned. It should be done as expeditiously as possible to prevent a rise in the temperature of the car. Even with prompt loading it is well to have a heavy canvas curtain hung in the door of the car to keep the outside air from entering. A better plan still is to have a door in the packing room which opens on the loading platform, and then connect the car and the packing room by means of a canvas corridor.

Having loaded the car and again observed the temperature, that the packer may know under just what conditions his goods start on their long journey, the doors are closed and sealed. The railroad agent knows the perishable character of the freight, and he issues instructions to add ice and salt while en route that low temperatures may be maintained. Or the packer himself may designate when and how he wants his car iced. When the doors are closed they should remain closed until the market is reached. If the packer has dressed and chilled the birds properly, if the refrigerator car is well insulated and built, if ice and salt are added as needed during the haul, the load is just as sure to reach the market a thousand miles away—that is, about five or six days as reckoned by time—in good condition as is a carload of cast iron. After the chickens reach the market they have still to go through the hands of the commission man, the retailer, and, perhaps, the storage warehouse. But that is another story.



## **SOME RESULTS OBTAINED IN STUDYING RIPENING BANANAS WITH THE RESPIRATION CALORIMETER.**

By C. F. LANGWORTHY and R. D. MILNER,

*Nutrition Investigations, Office of Experiment Stations.*

### INTRODUCTION.

Various agricultural products that were formerly available to the consumer only in rather limited areas and in quite restricted periods at certain definite seasons, may now be had almost everywhere and at practically all seasons of the year. This is due to modern methods of production and distribution. For many crops the kind of attention paid to details of growing, transportation, and marketing depends largely upon the market for which they are intended. The condition to which fruit, for instance, may be allowed to ripen depends upon the distance to which it is to be transported and the length of time it is to be kept before sale. Some fruit, for example the apple, may be allowed to ripen almost fully on the tree, and if proper attention is paid to handling and storage, may be kept for relatively long periods, and even with improvement of the quality of some varieties. The peach may retain its color and texture and appearance for a considerable time in storage, but its flavor can not be retained. Soft fruits like the strawberry can be kept for only a very short time without deterioration and decay. On the other hand, such fruits as the banana may be picked before the ripening process has begun, transported long distances, and ripened, under favorable conditions, according to the market demand.

### PROGRESS OF RIPENING.

The phases of fruit ripening are familiar and easy to follow. Development to full size, the gradual softening of tissue, the change in color (usually from green to red, yellow, purple, or blue), the change in flavor from acid, bitter, or astringent to mild, sweet, or bland, and the development of aroma are the principal steps. When fruit is fully ripened, the processes which have been going on do not cease, but continue with loss of quality. The texture grows too soft,

the flavor becomes flat or unpleasant, the aroma less agreeable, and the color turns frequently to brown or black, and changes occur more rapidly than during earlier stages of ripening. If microorganisms gain access to the fruit, through a broken skin, decay begins. If microorganisms do not gain entrance, the fruit gradually loses its moisture, becomes dry and shrunken, turns dark in color, and generally becomes inedible.

These changes in physical condition or characteristics are indications of the fact that the chemical nature of the fruit has been altered. In the laboratory considerable study has been made of fruit in different stages of ripening to determine what takes place. Some of the changes are quite easy to follow and are fairly well understood. These include the transformation of starch into sugar, the transformation of soluble tannin compounds into insoluble forms, the actual lessening of the quantity of acid, or the masking of the acid flavor by the accumulation of sugar, the softening of woody tissue, and the increase and storage of water (juice). On the other hand, the formation of compounds responsible for special flavor and aroma, such as volatile ethers, organic oils, etc., is not so easy to follow step by step. Yet much is known about the subject and information is accumulating.

Some of the reasons for these changes in the physical and chemical character of fruit were more nearly understood when it was learned that they were brought about by the action of bodies normally present in the fruit tissue, and called enzymes or unorganized ferments, the latter name being due to the fact that the changes which they bring about in the fruit are similar to those which yeast causes in a sugar solution. The action of the enzymes is influenced by physical conditions such as the degree of heat or amount of moisture, the presence or absence of oxygen and other gases, and the presence or absence of light. In some fruits these changes go on apparently about as well after the fruit is gathered as before; at least, the fruit ripened under favorable conditions after it is picked is practically like that ripened on the plant. Such fruit may be picked green and ripened as desired. In other cases the changes which occur in unripe fruits after gathering are not like those of normal ripening and such fruit must be allowed to ripen as completely as possible before picking. In all fruit the action of the vital processes which continue after ripening results ultimately in a loss of quality.

These conditions depend upon the fact that the fruit when taken from the plant, though it can no longer increase its size, still retains its capacity for development, and under favorable circumstances it continues certain of its normal vegetative functions after it is removed from the plant where they had their beginning.

## CONTROL OF RIPENING AND ITS COMMERCIAL IMPORTANCE.

In large measure, then, the successful handling of fruit so that its season may be prolonged and its quality maintained necessitates some means of retarding or accelerating ripening at will, in order that the desired quality may be attained at the most favorable time, and of retarding or preventing after-ripening processes which result in deterioration and decay, in order that the season of perfection may be maintained as long as possible. In common practice cold storage, heat insulation, and mechanical refrigeration are employed to retard the ripening of the fruit during shipment, or during the period in which it can be held until needed. Protection from the air, which is usually laden with mold spores and other minute forms of life which cause decay, also plays an important part in storage, since, if these minute forms of life find entrance into the fruit through small breaks in the skin, deterioration and decay will result. On the other hand, use is made of heat, air, and light to accelerate ripening. Sometimes bringing the fruit from the cold-storage warehouse into a room of ordinary temperature is sufficient; sometimes, as in the case of the banana, warmer temperatures are needed. In the application of these facts have grown up the great industries of fruit transportation, storage warehouse business, and other developments of the modern fruit trade. The methods employed, though on a very different scale, are largely those of the housekeeper who holds back the ripening of fruit by keeping it in a cool cellar, ice chest, or refrigerator, and hastens the ripening, for instance, when she puts an underripe melon in the sun, or puts her tomatoes in the kitchen window, or her hard apples and winter pears in a room of moderate temperature.

## LABORATORY STUDIES OF RIPENING BANANAS.

Numerous investigators have studied problems concerned with the ripening of fruits under different conditions. It is not the purpose in the present article to bring together the results of their efforts, but rather to cite a few of them for the purpose of showing the kind of work that has been and is being done with bananas to obtain knowledge of the principles on which may be based sound and satisfactory practice. For instance, the Jamaica department of agriculture<sup>1</sup> made studies of the gases given off by oranges and bananas, with particular reference to the possibilities of shipment. The carbon dioxide liberated by the ripening oranges was thought to be a preservative of bananas, though, on the other hand, gases or emanations given off by the oranges were thought to induce premature ripening. The practical deduction was drawn that separate storage was desirable for the two sorts of fruit during sea transportation.

---

<sup>1</sup>Ann. Rpt. Dept. Agr. [Jamaica], 1910, p. 6.

The chemical changes occurring in the ripening banana have been studied by a number of investigators, including Tallarico,<sup>1</sup> Yoshimura,<sup>2</sup> Reich,<sup>3</sup> and Bailey.<sup>4</sup> The results of such work as theirs have shown that during the ripening of the fruit the starch is transformed into saccharose (cane sugar), which gradually increases in amount and is, in turn, converted partly or wholly into a mixture of dextrose and levulose, "invert sugar," the proportion varying according to circumstances. The presence of other kinds of sugar has not been demonstrated.

Chemical analyses showed the green fruit to contain on an average about 1 per cent of reducing sugar, the amount increasing until the fruit when ripened to the yellow stage contained about 6 per cent and the brown (very ripe) fruit about 11 per cent. The amount of cane sugar increased from about 6 per cent in the green to a maximum of about 11 per cent in the yellow fruit and then diminished to about 6 per cent in the brown (very ripe) bananas. The total carbohydrates (starch, sugar, etc.), which made up about 21 per cent of the green fruit, reached a maximum of about 22 per cent in the yellow banana, and diminished to about 17 per cent in the brown (very ripe) fruit. Water and tannin substances remained fairly constant throughout the ripening. The changes in acids, in proteins, and in fats were also investigated, but no general deduction seems warranted.

Studies of the agencies which cause banana ripening have shown that various enzymes or "unorganized ferments," which are present normally in the banana, take part in the process. The presence of a number of these ferments has been demonstrated by various chemists. The action of catalase, an enzyme which accelerates oxidation processes, is intense during the ripening, but gradually disappears in the fully ripe and blackened fruit. Amylase, the enzyme transforming starch into sugar (maltose), is active during the early stages of ripening, and its presence has been found even in the ripened fruit. The presence of invertase (sucrase), which brings about the inversion of cane sugar to dextrose and levulose, has been shown in the unripe fruit, but its action is much more intense in the ripened fruit and gradually disappears as the ripening process ends. Alkalinity retards or inhibits its action. Protease, a protein-splitting ferment, has been found and is active during the ripening period, but its action probably diminishes and disappears afterwards. The action of the lipases, as fat-splitting enzymes are called, has been demonstrated in both the unripe and ripe fruit. The hydrolysis of raffinose by banana tissue was shown, but the specificity of the enzyme effecting this hydrolysis was not established.

<sup>1</sup> Arch. Farmacol. Sper. e Sci. Aff., 7 (1908), p. 27.

<sup>2</sup> Ztschr. Untersuch. Nahr. u. Genussmtl., 21 (1911), p. 406.

<sup>3</sup> Ztschr. Untersuch. Nahr. u. Genussmtl., 22 (1911), p. 208.

<sup>4</sup> Jour. Amer. Chem. Soc., 34 (1912), p. 1706.

In reporting the results of chemical studies which give data regarding the mineral matter as well as other constituents of unripe and ripe bananas, one investigator concluded that during the ripening of a bunch of bananas under commercial conditions the change of starch into sugar is normal, but that the inversion of cane sugar is slower than it is when the fruit ripens on the plant and that it progresses less favorably. Whenever the cane sugar content of the bananas was much higher than the invert sugar the fruit seemed unripe and lacking in aroma.

Studies of bananas during the ripening period, which have been made by the Bureau of Chemistry of this department, and which still await publication, deal with the changes which take place in the carbohydrates and other constituents and their causes. The respiration calorimeter experiments of the Office of Experiment Stations, such as are reported in this article, furnish information particularly regarding the respiration of the banana and the energy transformations involved, as measured by the gaseous exchange and heat output. The results correlate and supplement those obtained by chemical methods.

It has been suggested that the heat liberated by bananas during the active ripening period is due to bacterial activity rather than to enzymic changes, but results of bacteriological studies reported by E. M. Bailey<sup>1</sup> indicate that this is not the case.

From his studies he concludes that—

the inner portions of the pulp of sound bananas are practically sterile, but that the regions of the inner coats of the peel may be sparsely inhabited by bacteria, which, during normal ripening processes, are held in check, but subsequently find conditions favorable to growth. The resistance of the protective covering of the fruit to invasion by bacteria points to the circulation of the plant juice as a more probable channel of infection, and suggests that infection occurs while the fruit is still on the tree.

The laboratory work which has been done up to the present is not very large in amount, yet it has proved very useful. Out of the knowledge thus gained with bananas and other fruits and the larger volume of knowledge gained by experience the present elaborate system of shipping and storing bananas has developed and become an industry of great proportions and representing an enormous investment. The numerous losses and the uncertainty of results show that perfection in methods has not yet been attained.

Bananas are usually shipped by water from the tropical regions where they are grown to the distributing centers. Ships especially equipped for the purpose are used. The rapid growth of the industry may be seen when it is recalled that 30 or 40 years ago bananas were a great rarity in the United States, except in a few seaboard towns, while now they are common in every region. In Great

---

<sup>1</sup> Jour. Amer. Chem. Soc., 34 (1912), p. 1706.

Britain the condition is even more striking, for the banana, little known 15 years ago, is now the "poor man's fruit." The banana steamers, particularly those designed for long trips, are equipped with specially constructed chambers for holding the fruit so that bruising will be reduced to a minimum, and with special devices for forcing cooled, chilled, and dried air through the chambers so that the banana may remain green until it reaches its destination.

Although so much has been accomplished as a result of study and experience, other problems must be solved if losses are to be reduced to a minimum and quality insured. For this reason the study of banana-ripening problems was undertaken by the United States Department of Agriculture.

#### THE RESPIRATION CALORIMETER AS AN AID TO THE STUDY OF FRUIT RIPENING.

To assist in satisfying the demand for such information the department has given considerable attention to the study of the problems of fruit ripening. The changes of physical and chemical nature which occur in fruit ripening under various conditions have been followed. It has been found that these changes are accomplished by the taking of oxygen from the atmosphere and the liberation of carbon dioxide, and that, as in the case of most chemical changes of this character, there is a corresponding liberation of heat. In other words, the ripening fruit resembles an animal in that it breathes in oxygen and gives off carbon dioxide, and in the performance of its vital processes liberates heat. For comprehensive knowledge regarding the changes taking place in the ripening fruit, some method of studying simultaneously the gaseous exchange and the energy transformation occurring during the process was essential. The results obtained with the respiration calorimeter employed in the study of such factors in investigations in human physiology indicated that such an apparatus that could be employed likewise in similar investigations in plant physiology would be advantageous, and some tests with fruit in the chamber of the large calorimeter showed that such a device could be readily adapted for such work. Accordingly, as pointed out in an earlier volume<sup>1</sup> of this series, cooperative experiments were undertaken by the Bureau of Chemistry and the Office of Experiment Stations. To facilitate the work a special respiration calorimeter of suitable size was constructed for the purpose. The special problem selected was the study of bananas during the period which corresponds to commercial ripening in banana cellars or warehouses; that is, the period during which the green banana as received from the shipper is held in the warm, moist conditions, until it ripens, turns yellow, and is ready for the retailer, which requires approximately one week. The results of a typical

<sup>1</sup> U. S. Dept. Agr. Yearbook 1910, p. 307.

experiment on the ripening of bananas in this apparatus are discussed in the pages beyond. In general, it may be said that the phenomena observed and studied quantitatively in these respiration-calorimeter experiments with bananas yield new data for judging of the character and extent of the changes involved in ripening. It is believed that the results of such studies, taken together with those obtained by other methods, when interpreted, will be of value to the producer, shipper, and dealer by enabling them to improve their methods, lessen losses, and improve quality.

The respiration calorimeter with which the experiment was made was designed especially for investigations of this character, and has been described in considerable detail in former publications of the department.<sup>1</sup> In brief, it may be explained that the significant feature of the apparatus consists of a respiration chamber that is both air tight and heat proof, which affords an opportunity to measure the gaseous exchange and energy transformation that take place within it.

To measure the gaseous exchange, the air of the chamber is kept in constant circulation, being withdrawn by a rotary air pump through a pipe in one wall, passed through purifying devices and returned to the chamber through another pipe, at a rate of circulation of about 10 liters per minute.

In the train of purifying devices the air is passed first through sulphuric acid, which removes all the water vapor from it, and next through soda lime, which removes all the carbon dioxide. The sulphuric acid and soda lime bottles are weighed at stated intervals, the increase in weight showing how much water and carbon dioxide were absorbed during the intervening period.

At the beginning and end of each period analyses of the air remaining in the chamber are made, which show what changes have taken place in the moisture and carbon-dioxide content of the air during the period. These data are taken into account with those for the quantities absorbed from the circulating air to determine the amounts produced during the period. Changes in volume of the air of the chamber due to differences of temperature and of barometric pressure at the beginning and end of the period are also considered.

Oxygen to replace that used by the bananas is admitted to the chamber from a cylinder which is weighed at the beginning and end of the period. The loss in weight of the cylinder, the gain or loss in the percentage of oxygen in the residual air, as determined by analysis, and the difference in volume due to changes in temperature and barometric pressure are data from which the amounts of oxygen consumed by the fruit are determined.

In order that the energy transformations occurring within the chamber may be measured, the gain or loss of heat through the walls

---

<sup>1</sup> U. S. Dept. Agr. Yearbooks 1910, p. 307; 1911, p. 491.

is prevented. To this end the chamber has double parallel walls of sheet copper separated by a small air space. Provision is made for keeping the temperature of the outer wall exactly the same as that of the inner wall, in which case heat will not pass from one to the other in either direction.

Part of the heat generated by the bananas is carried out as latent heat of water vapor in the ventilating air current. This is determined by multiplying the weight of water vapor removed from the air by the factor 0.586, which represents the amount of heat required to vaporize one gram of water at 20° C. The remainder of the heat liberated in the chamber is taken up by a current of cold water flowing in a coil of copper pipe, called the "heat absorber," hanging in the air of the chamber surrounding the bananas. The quantity of water flowing in a given period through the heat absorber is weighed. The difference between the temperature of the water just as it enters and that just as it leaves the calorimeter chamber is continuously recorded automatically. The product of the weight of water for a given period and its average temperature difference is the amount of heat carried out during the period. The sum of these two quantities is practically the amount of heat produced by the bananas, though changes in temperature of the walls of the calorimeter and in the bananas themselves are also taken into consideration.

The temperature of the water entering the heat absorber is automatically maintained constant at any point desired within 0.05°. This temperature and the rate of flow of water are regulated so that the absorption of heat in the chamber will follow its generation in such manner that the temperature of the air in the chamber will remain practically constant at any given point.

Once an experiment has begun, the apparatus, as a calorimeter, because of improvements in it and in methods, is practically self-operating, yet very accurate. The instrument as a respiration apparatus has been improved also until the work of operating it has been greatly reduced. The purifying devices require attention only at the ends of the periods, when change is made from one train to the other. The train that has been in use is then weighed, replenished, and again connected and tested, in readiness for the change at the end of the new period.

The details of an experiment with a bunch of bananas in this respiration calorimeter are given in the following pages.

#### AN EXPERIMENT WITH BANANAS RIPENED IN THE RESPIRATION CALORIMETER.

Bananas usually come to the Washington market in the early part of the week, and the best ones are commonly disposed of quickly. For these experiments bananas are generally obtained shortly after they are unloaded from the freight car, so as to have them as green



as possible, and care is taken to make selection from those that show no indication that ripening has begun. This affords opportunity to follow the changes occurring during the whole of the commercial ripening period. It is a part of the plan followed to study bananas of different grades. The bunch used in the present experiment, however, was somewhat more mature than those usually obtained. As a whole the shipment from which this bunch was selected was not particularly fine, and the bunch chosen was not first grade, being rather what would be known commercially as "seconds," and not a particularly fine quality of that grade. It was a rather small-sized bunch, weighing only 12.29 kilograms when put into the respiration chamber, and the bananas on it were also only medium or small in size. The stock from which the bananas were selected was not as green as the average shipment, but one of the greenest bunches was taken. When the fruit reached the laboratory, toward the middle of the afternoon on January 2, its temperature was considerably below 20° C., which was that at which it was intended to keep the bananas during the ripening period. The bunch was therefore allowed to hang in the laboratory until about 10 o'clock on the following morning, at which time it had become sufficiently warm to be put into the calorimeter chamber. By this time there were faint suggestions of changes of color of the skin of the banana from green to yellow. The bunch was then weighed and put directly into the respiration chamber and the cover of the latter sealed on. The usual analysis of the air residual in the chamber at the time of sealing in the bananas was not made, but all the carbon dioxid or water vapor generated in it was retained there. The purifying system was made tight and the air circulation started by 2 p. m., January 3, but the recording of experimental data did not begin until a little later, the intervening time being employed as usual in bringing the calorimeter into a condition of thermal equilibrium between the inside and outside metal walls of the chamber. At 5.45 p. m., everything being in readiness for the experiment, an analysis was made of the residual air in the chamber, the circulating air was shunted from one purifying system to the other, and the first regular period of the experiment began.

The experiment as a whole continued almost five days, and was divided into five periods each of practically a day's duration. The ripening of the fruit continued regularly, and each day the change in color from green to yellow, as seen through the window of the respiration calorimeter, became more noticeable. On the morning of January 6, though a bit of green color still persisted at the extreme tip, the bananas appeared to be fully as ripe as they would be found under ordinary commercial conditions, if not indeed a little beyond that stage. Dark patches on the skin were quite distinct, and

some dark lines appeared along the ridges on the fruit. Some of the individual bananas seemed to be a little shrunken. However, in order that there might be no doubt as to the full ripeness of the bananas when taken from the respiration chamber, the experiment was continued until the close of the following day, January 7.

At the end of the experimental period the cover of the respiration chamber was unsealed, and the fruit was removed and weighed immediately, the weight of the bunch being 11.59 kilos. The fruit was then examined as to its commercial quality. The skin of the bananas felt somewhat dry and appeared to be very slightly wilted, with dark lines and patches which were quite pronounced. The pulp was somewhat dry and mealy, just tending toward too great softness, though it was not sour or overripe; in fact, it was more nearly in the best condition for eating than bananas commonly sold in the market, since under commercial conditions fruit that has reached that stage of ripeness begins so soon to pass to overripeness and to decay that it can no longer be sold for good prices. The flavor of the fruit was delicious, and its aroma, which was noticed especially on opening the respiration chamber, was very pleasing.

In brief, bananas in the condition of these at the close of the experiment would be much more satisfactory to the consumer than the underripe fruits so commonly sold. To the dealer, on the other hand, they would not be so satisfactory unless they could be sold quickly, because if they had to be kept any length of time they would become overripe and would not bring good prices. The data obtained in the experiment are summarized in the following table:

*Summary of data obtained in respiration calorimeter experiments with ripening bananas.*

Date.	Duration of period.	Temperature of air in chamber.	Temperature of bananas.	Per cent of oxygen in air.	Water produced.	Carbon dioxide produced.	Oxygen consumed.	Heat produced.	Respiratory quotient.	Thermal quotient.
	<i>Hrs. min.</i>	<i>° C.</i>	<i>° C.</i>		<i>Gm.</i>	<i>Gm.</i>	<i>Liters.</i>	<i>Calories.</i>		
Jan. 2.....	7 45	20.6	21.4	18.00	122.7	10.9	16.0	13.3	0.92	.....
Jan. 3.....	23 15	20.9	22.4	17.69	124.2	43.6	21.6	131.0	1.03	3.00
Jan. 4.....	23 ..	20.6	21.6	20.41	122.4	43.8	22.2	113.0	1.00	2.58
Jan. 5.....	24 ..	20.5	21.3	19.43	116.9	38.7	18.4	100.1	1.07	2.56
Jan. 6.....	24 ..	20.5	20.7	20.01	112.3	33.8	16.6	87.0	1.04	2.57
Jan. 7.....	23 40	20.5	21.1	24.23	106.2	31.3	13.7	87.0	1.16	2.78
Totals and averages...	125 40	.....	.....	.....	604.7	202.1	98.5	531.4	1.04	2.68

<sup>1</sup> These figures do not include corrections for the amounts present in the residual air of the chamber at the beginning of the preliminary period, since no analysis of the air was made at that time.

<sup>2</sup> This figure for Jan. 2 represents only the heat due to the vaporization of the water in the outgoing air.

<sup>3</sup> This figure for heat measured during this period is somewhat larger than that actually produced by the bananas.

The first two columns in the table on page 302 show the date and the length of the several periods into which the experiment was divided. The preliminary period, as already explained, continued from the time when the bananas were sealed in the respiration chamber until the circulating-air system was changed from one set of purifying devices to the other. For convenience the first and second day periods were made a little less than 24 hours each, while the last period ended 20 minutes before the completion of the full day.

The second column shows the temperature of the air in the chamber at the end of each of the several experimental periods. The third column shows the temperature of the bananas themselves, as indicated by a special electrical resistance thermometer, long and slender in form, which was pushed between the bananas deep into the bunch, but which did not actually penetrate the fruit. The temperatures of both the air and the bananas were read at frequent intervals during each day, so that any fluctuations could be readily detected. In the case of the air surrounding the bananas, care was taken to prevent any very wide fluctuation in temperature. The temperature of the air in the chamber is regulated by controlling either the rate of flow or the temperature of the water circulating in the heat absorber adjacent to the bunch of bananas in the respiration chamber. The temperature of the bananas themselves, of course, varied with the activity of the ripening processes. It is essential to know the change in the temperature of the fruit in order to make correction for the amount of heat involved in such change in determining the total quantity of heat produced by the bananas. It will be observed that the temperature was highest during the first regular period, January 3, and that from this day it fell off gradually until the last day, January 7, at which time it was for some reason apparently slightly higher than on the day just preceding.

The fourth column shows the percentage of oxygen in the air of the respiration chamber at the end of each period, as determined by analysis of a sample of air drawn from the chamber at that time. It is essential to know what change has taken place in the oxygen content of the air at the end of a given period in order to determine how much oxygen has been used during the period. The data are given here simply to show the limits of variation that were found. They give no indication, however, of the proportion of oxygen present in the air during the whole of the period, as this would vary with changes in the temperature or the barometric pressure of the air, or with the care taken to fill the air tension equalizer always to the same point and at regular intervals. Most of the time oxygen was introduced into the chamber in such quantities as would keep the proportion of oxygen in the air not far from 20 per cent. During the second

experimental period, when the activity of the banana was greatest, the temperature and barometric pressure conditions were such that the proportion of oxygen in the air diminished somewhat, but it was increased to normal again during the succeeding period and was maintained at normal during the rest of the experiment. The high percentage shown in the table at the end of the last period was due to the fact that an excess of oxygen was accidentally admitted just before the last period was terminated.

The fifth column shows the amount of water produced by the bananas during each period. This is ascertained from a gain in weight of the first water absorber (a bottle containing concentrated sulphuric acid) in the air-purifying system, and from the increase or decrease in the quantity of moisture present in the air residual in the chamber at the beginning and end of the period. At the end of the preliminary period, January 2, the water absorber had gained 22.7 grams, owing to moisture removed from the circulating air. It can not be stated how closely this represents the total quantity of moisture produced during this period, because the air was not analyzed at the beginning of the period, hence the increase in the quantity of moisture residual in the air of the chamber could not be determined. The quantity of moisture given off by the ripening bananas in the first regular period would appear, from the table, to be slightly larger than that of any of the others, but that in the second period was practically identical with it when the small difference in the length of the periods is taken into account. There was a small but continuous decrease in quantity of moisture eliminated by the bananas in each successive period, in conformity with the decrease in the intensity of the ripening processes.

The moisture content of the air surrounding the bananas in the chamber depends entirely on the elimination of moisture by the bananas themselves, because the circulating air returning to the chamber is absolutely dry after having passed through the purifying system. During the whole of the experiment the relative humidity of the air was somewhat below the point of saturation for the temperature of the air. It was greatest during the first two periods, and decreased gradually as the activity of the bananas diminished.

The total quantity of water eliminated by the bananas during the whole of the experiment was 604.7 grams, which was almost one-twentieth, or 4.9 per cent, of the total weight of the bananas put into the chamber.

The quantities of carbon dioxid eliminated by the bananas during the several periods are shown in the sixth column. These are determined from the increase in the weights of the carbon dioxid absorber (a bottle of soda lime followed by a bottle of sulphuric acid) of the

air-purifying system, together with the changes in the quantities of carbon dioxide in the air of the chamber at the end of each period. The quantity given for the preliminary period, January 2, is only approximate, because no correction was made for the amount present in the air of the chamber at the beginning of this period. As in the case of the water, the largest amounts of carbon dioxide were eliminated the first two experimental days, being almost the same for both. The quantities for the succeeding days showed a gradual decrease.

The quantities of oxygen utilized by the bananas for the ripening processes are indicated in the seventh column. At least, these represent the quantities taken by the fruit from the circulating air, as shown by the loss in the weight of the cylinder from which the oxygen was supplied to the chamber, and the change in the oxygen content of the air of the chamber at the end of each period. It is possible, of course, that oxygen may have been available to the fruit from some other source also. It is conceivable, for instance, that there may have been a supply of oxygen in the tissues of the plant, or oxygen may have been derived from the transformation of some of the compounds of the fruit. However, it is noteworthy in this connection that utilization of oxygen from the air kept pace very evenly with the elimination of carbon dioxide. This is shown quite clearly by the figures in the ninth column, designated as "respiratory quotients."

The respiratory quotient represents the ratio of the volume of oxygen consumed to that of the carbon dioxide produced; that is, it is the quotient found by dividing the latter by the former. In the combustion of carbohydrate material, the volume of carbon dioxide produced is exactly the same as that of oxygen consumed; that is, the respiratory quotient is 1.00. It is noticeable that for each of the regular periods of this experiment the respiratory quotient is not far from unity, the most noticeable deviation being on the last experimental day, January 7. Considering the experiment as a whole, the ratio between the carbon dioxide production and oxygen consumption is 1.04. This appears to be at least a fair indication that the metabolic processes representing the ripening of the bananas were essentially equivalent to an oxidation of carbohydrate.

The quantity of heat produced by the bananas, as a result of the transformations mentioned above, is indicated in the eighth column. For the preliminary period, January 2, the quantity given represents only the heat due to the vaporization of the water absorbed from the air leaving the respiration chamber, because part of the time represented by this period was utilized to bring the internal and external metal walls of the chamber into thermal equilibrium, in which process heat may be gained or lost by the chamber through

the walls, and this would affect the quantity of heat measured by the calorimeter, and supposed to be given off by the bananas.

As a matter of fact, such an error actually occurred in the measurements of heat during the first regular period of the experiment, January 3. The quantity indicated by the table as having been eliminated by the bananas is 131 calories. This value, however, is somewhat too large, because during the early part of this period there was not thermal equilibrium between the inner and outer metal walls at the bottom of the chamber, nor between the ingoing and outgoing air. Heat was being introduced at both places, so that it is certain that the amount of heat measured by the calorimeter in this period is larger than that produced by the bananas, though just how much larger can not be exactly stated.

In the succeeding experimental period, January 4, which was only 15 minutes shorter than the one before it, the amounts of water (122.4 grams) and of carbon dioxid (43.8 grams) given off and of oxygen (22.2 grams) absorbed by the bananas were almost identical with the corresponding quantities of the previous period, but the amount of heat measured in the second period was only 113 calories. It is very probable that this more nearly represents the amount of heat generated in the first period also than the value recorded in the table.

There was a gradual diminution in the quantity of heat produced in the succeeding periods, although in the last period, January 7, the quantity shown in the table is exactly the same as that for the next to the last period. This appears to have been due to the fact that the temperature of the bananas seems for some reason to have increased somewhat toward the close of the final period, and the amount of heat involved in such a temperature increase is, of course, included, together with that measured in other ways, in calculating the total amount of heat produced by the bananas during the time covered.

The figures in the last column of the table are designated as "thermal quotients." The figure for each period simply represents the numerical ratio between the grams of carbon dioxid produced and the calories of heat produced during the period. In the combustion of carbohydrate (starch), for each gram of carbon dioxid produced 2.58 calories of heat is produced. It is noteworthy that this figure is almost identical with that for three of the periods in this experiment. The thermal quotient for the first period is given as 3.00, but this is too large, because of the fact explained above, that the heat production during this period is known to be too large. If the heat production given in the table for the second period were taken to represent that for the first period also, which is undoubt-

edly more nearly correct than the figure actually given for this period, the thermal quotient for that period would be 2.6. The increase in the heat production for the last period referred to above results also in a thermal quotient slightly larger than that for the remaining periods. The quotient for the experiment as a whole is 2.63. This value, like the respiratory quotient, may also be considered a fair indication that the metabolic activity in the banana during this experiment was equivalent to those involved in the combustion of carbohydrate.

The data obtained in this experiment do not show with certainty the particular carbohydrate which was oxidized. It may have been any one or some of all of the carbohydrates present in the fruit, namely, starch, cane sugar, or invert sugar. This is apparent when it is recalled that approximately 125 grams of starch, or 130 grams of cane sugar, or 140 grams of invert sugar would yield on combustion the quantities of carbon dioxid and energy produced by this bunch of bananas. The fact that the value found agrees so nearly with the theoretical value for any one of these carbohydrates indicates that other constituents of the banana, as tannin compounds, aromatic and flavoring bodies, and proteids were not concerned in the energy transformations to any extent, or, if they were, that the amount of heat they utilized exactly balanced the amount they produced.

#### GENERAL CONCLUSIONS.

A consideration of available experimental and other data shows that the successful handling of fruit during transportation, in the cold-storage warehouse, and in the home depends upon a knowledge of the changes which take place in ripening, after ripening, and decay, and the causes of these changes and ways in which they may be controlled. Present practice is based on knowledge gained by experience, supplemented by work carried on in the laboratory.

The respiration calorimeter offers a new means for studying fruit-ripening problems, and the results are briefly presented of a study made with bananas during the active ripening period. The results show that the ripening changes progress regularly to a maximum and then decline; that at its greatest intensity the heat produced is equivalent to approximately one calorie per hour per kilogram of bananas. The heat liberated is a measure of the activity of one or more of the ripening processes. Analysis has shown that during ripening the banana starch is transformed into cane sugar and the cane sugar into invert sugar, and that there are important changes in the character of the tannin compounds, and that other changes occur, brought about by the production of aroma and flavor bodies, and perhaps in other ways. It has also been found that in addition to the trans-

formation of carbohydrates there is an actual loss of this food constituent during ripening. From the data for oxygen consumption, carbon dioxide, and heat output it appears that the heat liberated by the ripening bananas is largely due to the destruction of carbohydrate. The results here recorded and discussed represent only a part of the material which is being accumulated. No attempt is made at this time to draw deductions regarding the practical applications which can be made, as this may be done more properly when experiments now under way are completed.



## CROP SAFETY ON MOUNTAIN SLOPES.

By J. CECIL ALTER,

*Observer, United States Weather Bureau.*

### INTRODUCTORY.

When "Jim" Bridger, the pioneer Indian trader, told Brigham Young and his Mormon immigrants that farming could not be practiced in the Rocky Mountains, and that he would "give one thousand dollars in gold for the first bushel of wheat raised in the Salt Lake Valley," he evidently had in mind the mountain blizzards that lash themselves about the cloud-hemmed peaks and the desert-dry slopes and plains whose very vegetation—the characterless weather-worn sage—betokens extreme summer temperatures in certain districts and severe winter cold in certain other mountain regions.

But Colonel Bridger was not a true prophet, for to-day, while there certainly are numerous superheated deserts and overexposed slopes imprisoned in the Rocky Mountain fastnesses, where even native animals sometimes perish from exposure to the weather, there are many notable agricultural and fruit districts in the neighborhood of three-quarters of a mile above sea level that have climates of rare equability and gentleness, with an ideal progression of the seasons, where floriculture, horticulture, and agriculture are intensively and quite successfully practiced.

### MOUNTAINS AS AN AGRICULTURAL ASSET.

These favored regions in many instances are on the lower slopes of mountains whose peaks dwell in almost eternal winter, and yet the fierce climate aloft does not descend upon the fields at the mountain's foot even in winter; and, as we become familiar with the conditions, we begin to comprehend the interesting fact that mountains, having certain favorable configurations, are actual assets to the farmer as weather producers and regulators, and form unique protection against the vicissitudes of climate so often found where elevation above sea level tends to expose the land.

The level farm on a level plain is exposed to conditions of winds, storms, and sunshine that are normal for that general latitude and longitude, but in the mountains the sun's rays glance about on the various slopes, collecting in one place and scattering away from another; and the winds and storms are prevented from sweeping over the agricultural valleys in unbridled frenzy by the protecting mountain barricades. Thus there are mountain lands that are totally unfit for agriculture by reason of severe climatic conditions, while only a few miles away will be found the choicest of lands in the finest of climates, depending for these especial characteristics or peculiarities on the way the sun's rays fall on the surface of the land in the daytime, and the way the surface air flows or drains over it at night.

#### ESSENTIAL FEATURES OF MOUNTAIN FARMS.

The land must be sloping, but it must slope in the right direction and at the proper angle; it may incline toward the farmer's homestead, or away from it if that seems more desirable; it may slope evenly and gradually away from the lines of irrigation ditches, or, if it be an arid farm, it may slope gently away from the snow-laden hillsides in a very advantageous manner; and it may even slope downward to market by a good and easy road; yet more important than all these slopes is the inclination in the right direction with relation to the sun's rays and to adjacent canyons and drainways for the higher mountain air.

Primarily these subtle slope influences are entirely good, for it is by virtue of them that the mountain-locked valleys are vigorously ventilated day after day, rendering them wholesome and habitable, but from an agricultural viewpoint the slope may cause a climate totally bad, or partially bad, and the mountain farmer must look carefully beyond superficial appearances, and, it must be stated with regret, beyond much of the exploitation literature, for those favorable slopes down which he may induce the dollars to roll into his bank account.

The maximum amount of heat is received by the land from the sun when the sun's rays fall directly upon it—that is, at a right angle to the soil surface—but in our latitude this can occur only where the land slopes several degrees toward the south or toward the sun. A northerly slope, be it ever so slight, is a slightly cooler slope, and this condition includes a multitude of accompanying influences. Evaporation will be considerably less, and dry farming may be more safely practiced, as the moisture can be more easily conserved; on the other hand, since it receives less heat from the sun, the spring season on such a slope will be slightly delayed, crops

will be less precocious, and plant growth, after having started late, will be appreciably slower throughout the summer. This is often manifested by the fact that an alfalfa field on a north slope will yield but three crops safely, while a field on a southerly slope will yield four.

It is almost exactly as if the place were removed a much greater distance from the Equator; though a place nearer the North Pole would really be in the sunshine a greater number of hours per day, for the days are longer in summer with increase in latitude. It is for this reason that the Manitoba, Saskatchewan, and Alberta countries are good grain producers. The sun's rays are seriously slanted and their good effects greatly lessened, yet the days are so much longer that grain can be successfully grown there, whereas it might be a failure in middle latitudes on the same angular slope from the sun because of our shorter days.

#### LONGITUDINAL COMPARISON OF SLOPE.

Considering the surface slope only, a field slanting  $1^\circ$  to the north lies in the same solar climate as a level field located 70 miles farther north, on account of the curvature of the earth's surface. A field sloping  $5^\circ$  to the north in southern Utah (latitude of southern Missouri), which is not an unusual slope for a farm, is equal to a southern Idaho latitude (latitude of central Iowa). Likewise, a  $5^\circ$  slope to the south in southern Idaho is in the same solar climate as is a level field in the latitude of southern Utah, 350 miles nearer the Equator. It is a fact that the Santa Clara Valley in southern Utah, having a good southerly slope, has a climate, with resultant crop conditions, similar to those of Phoenix and Yuma, Ariz., except that summer maximum temperatures are not so high because of a good air drainage over this region.

#### ABSORPTION AND RADIATION OF HEAT.

An oval or convex surface of a knoll in an orchard or field receives less heat from the sun than a level tract, thus helping to keep the daytime temperatures lower; and at night a greater loss of heat is experienced than from a level tract, so that its night-time temperatures also often are lower. Therefore the climate of the top of a knoll or a hill is colder than the climate on a level field. Also, a narrow valley, or a small round one, receives more heat in the daytime by the collection of the rays and loses less at night by radiation than does a level tract, and its climate, therefore, is appreciably warmer; it is a great deal warmer than the knoll or ridge, though the valley and the ridge under consideration be in the same general altitude. For this reason many very high round or par-

tially inclosed valleys are good crop regions. This temperature difference between hill and hollow, due to differences of radiation, is greatly accentuated by winds and by air drainage.

#### EVAPORATION OF MOISTURE.

A storage reservoir for irrigation water located in a bowl-like depression in the tops of the mountains will not only contain water that is comparatively warm, but it will suffer a great loss by evaporation, whereas a reservoir located in an east-and-west canyon in the shadow of a south ridge or mountain may lose only a fraction as much water by evaporation as the reservoir exposed in the sun between the sloping hills. Narrow agricultural valleys experience the same sort of effect from the sun, and their crops in springtime are very precocious, often dangerously so, when there is a probability of injury from late spring frosts. The wider valleys show the result of this collection of the sun's heat much less than the smaller, narrower valleys.

The northerly slopes of the mountain, from which the snow and rain are much more slowly evaporated, are where we find the mountain forests, while the southerly slopes, which are quickly dried in the sun after a storm, are usually covered with a ragged blanket of sagebrush, and often carry no vegetation at all.

#### DANGER OF FROST.

The greatest weather enemy in all fruit districts, east and west, is the late vagrant spring frost which throws itself into the lap of spring without ceremony—the frost that goes sneaking across the country under the immense high air-pressure areas that are occasionally seen on the weather maps, and kills the fruit buds after all nature has apparently concluded that spring has safely arrived.

In the mountainous districts the maximum action of these frost-producing high-pressure areas is considerably hindered, but it is unmitigated in the Plains States and in the East. The dangerous sap-starting warm periods of winter occur in the mountains from the same sort of low barometer areas as in the Mississippi Valley and the East, but the progress of these areas is greatly retarded and their effect minimized by the high mountain peaks and the general elevation of the land. A winter warm spell of sufficient length to start the sap practically never occurs in the mountain valleys, where a more equable condition of the storm-carrying atmosphere is enforced by the impeding mountains, and thus the trees are subjected to less rigorous winter weather and are awakened from their winter dormancy in a perfectly natural manner when spring has duly arrived,

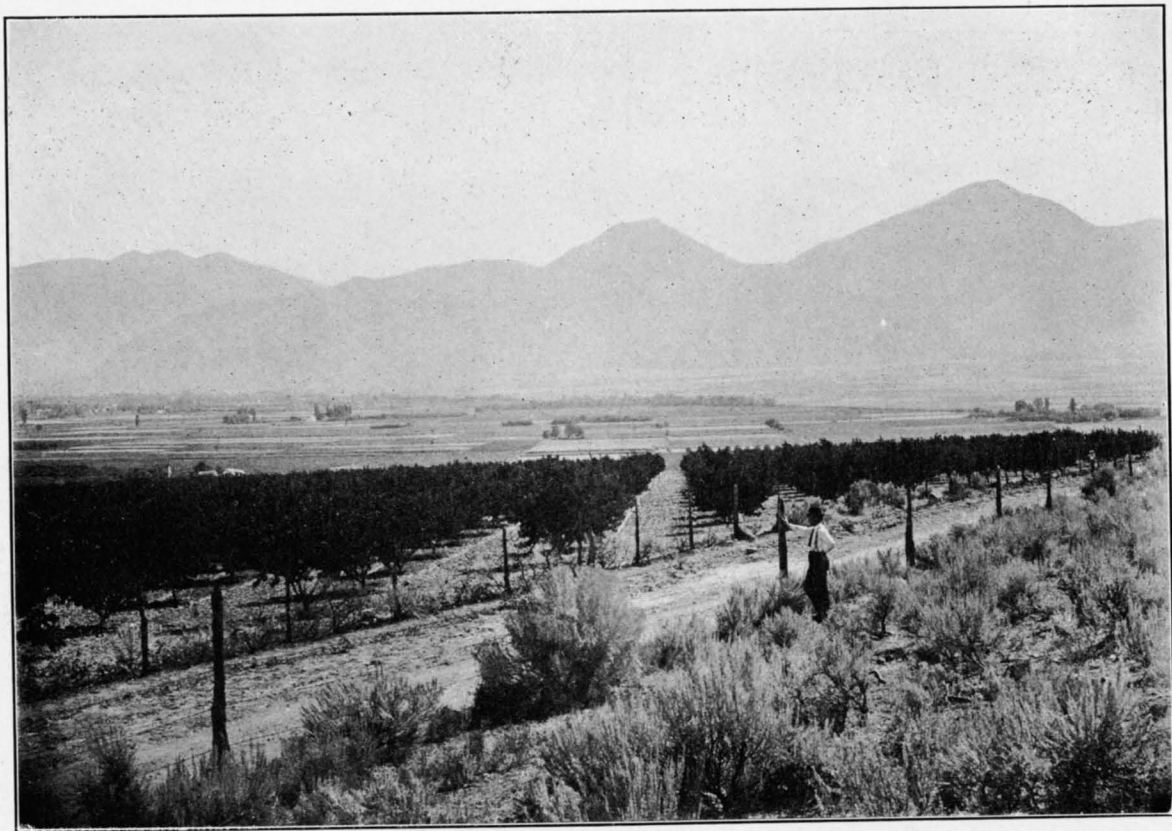

A VIEW FROM FOOTHILLS LOOKING ACROSS AN ARM OF UTAH VALLEY.

[Showing fruit trees on slopes, and grain and vegetable farms in bottoms, a natural distribution, enforced by climatic conditions caused principally by mountain air drainage.]

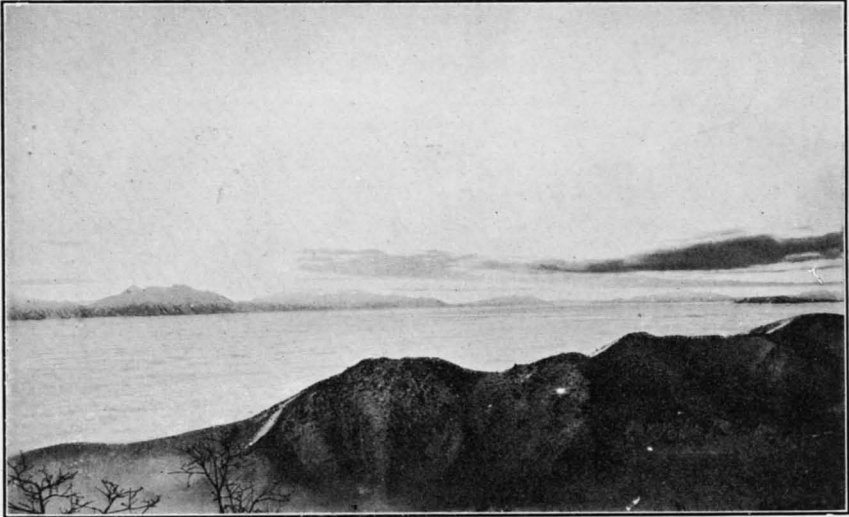

FIG. 1.—A VIEW ACROSS THE SALT LAKE VALLEY FROM AN ELEVATION OF ABOUT 5,900 FEET, OR ABOUT 1,600 FEET ABOVE THE VALLEY FLOOR.

[Showing fog layer, which is probably about 1,000 feet thick and rests on the ground. Phenomenon due to air drainage from many canyons.]

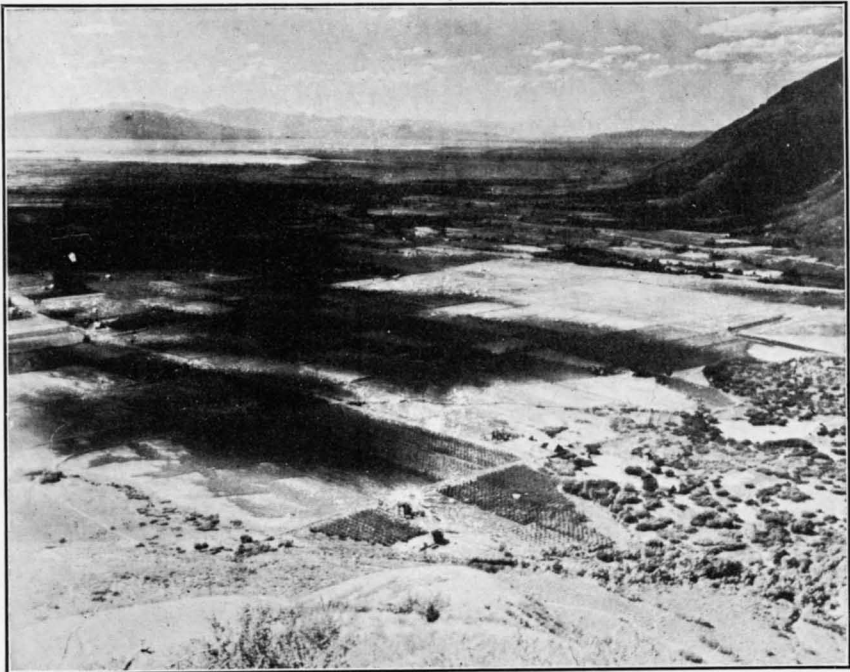

FIG. 2.—MAPLEWOOD CHERRY FARM (TRIANGULAR), SHELTERED UNDER MOUTH OF MAPLE CANYON FROM STRONG WINDS, NEAR MAPLETON, UTAH.

[Lower  $1\frac{1}{4}$  inches of picture, only, appropriate. Distant view includes Springville, Provo, and Utah Lake, looking northwest.]

having been weakened neither by excessive cold nor unseasonable warmth.

A mere glance across a mountain orchard of uniform, even-sized trees shows that few of them have been winterkilled or even injured by excessive winter cold, and the Eastern fruit grower who has seen the sap start in his orchard during a warm February and has, later, chopped the ruined trees down for firewood because of a vicious freeze in March will appreciate the advantage of a great range of mountains to break up the large storms which are shown from time to time on the daily weather maps of the Weather Bureau, and which produce the unexpected extremes of weather. (Pl. XXII.)

#### EFFECT OF SHADE.

A greater influence for good, however, from the mountains in favor of the fruit grower is the shortening of the daylight; that is, the delaying of the morning sunshine and the advancing of the evening shadows, by the elevation of the horizon, both of which are important aids in delaying the opening of fruit buds until spring has actually arrived.

It will be seen that southerly exposures which offer no such shadow protection from mountains to the east and west will permit a much earlier budding of the fruit and will thus increase the probability of loss by subsequent freezes. This shadow protection for the orchards in the Salt Lake Valley, for instance, is very pronounced, where the Wasatch Mountains delay the appearance of the sun on the orchards from 30 minutes to 2 hours in the morning, while the protection from the Oquirrh Mountains to the west amounts to from a quarter to half as much in the evening, depending on the location of the orchard in question. This lessens the daily number of hours of sunshine on the orchards and consequently delays the time of budding and blooming until a more convenient season.

#### EFFECTS OF THAWING.

This, however, is only one of a number of mountain influences that tend to make fruit growing safe. These very mountain shadows are the means of saving a great deal of fruit every spring that actually has been frosted and which would be lost if the full might of the sunshine were thrown upon the buds immediately after sunrise. It is a well-known fact that a bud can withstand a temperature considerably below freezing for a great length of time provided it is thawed out gradually. It is not the freezing that brings pain in the fingers, but it is the thawing out that makes the trouble. And so it is with the

fruit buds to a great extent; if they can be warmed slowly they will recover from a severe freeze.

The eastern orchardist, who always has been advised to place his orchard on a northeast slope as offering the least of several climatic evils, has no protection from the sudden thawing of the buds which results in so much damage, but the orchard that lies in the shadow of the mountains until the more distant valley air has been warmed in the sunshine and has gradually flowed across to the mountain-shaded orchard to take the ice out of the buds slowly, recovers safely from a freeze that, occurring anywhere but in a great natural laboratory, would prove disastrous.

#### AIR DRAINAGE.

There is still another arm of safety that the mountain extends out over the orchards at its foot—one that has blessed into fruitage thousands of acres of orchards amidst weather conditions that have ruined many less favored regions—and that is air drainage—the helpful influence of a steady stream or current of air which usually flows down a mountain slope all night, ceasing only when the morning sun appears and changes the direction of the flow gently back up the slope.

As soon as darkness overspreads the valley in the evening the cool air begins to settle into the lowest places and to become quiet. Under a clear sky it will then gradually grow cooler by radiation until morning, and for this very good reason the valley bottoms, where the dead, quiet, cold air settles at night, are carefully avoided by orchardists. Gradually during the night the lower parts of the valley fill with cold air, and this dead-air district enlarges and creeps up the slope as the slowly-cooling air from the mountains flows down by reason of its greater density, under the rising warm air over the valley, which spreads at the higher elevations to the orchard districts.

Because of this stratified formation of air of differing temperatures and consequent differing densities in mountain valleys, it is usual to find great variations in the advancement of the seasons, as shown by the differing stages of common crops and vegetation development, even along the same parallel of latitude, because of the wide differences in exposure and elevation presented. It is interesting to note that in many Utah valleys neighborhoods within a very few miles of each other and differing only a few hundred feet in elevation have climates so different as to make the stages of the growth of common crops several weeks apart.

The cultivated portion of the Salt Lake Valley south of Salt Lake City is about 10 miles wide, having an altitude along the Jordan River of about 4,250 feet above sea level. From here the ground rises gradually toward the east to the Wasatch Mountains, and



toward the west to the Oquirrh Mountains, where the agricultural lands merge into the foothills at an average altitude of about 4,450 feet, a total rise of about 200 feet in something less than 5 miles. In fact, the valley floor in places is so wide and flat as to confine this rise to within approximately 2 miles.

Such is the case between Wandamere, a suburb of Salt Lake City, about 5 miles south and 1 mile east of the center of the city, and East Mill Creek, a community next to the Wasatch foothills, 2 miles nearly due east of Wandamere. The general conditions noted along the slope between these two places prevail on the same slope to the southward for a distance of 10 or 12 miles, and also across the valley toward the west, on the slope up to the Oquirrh Mountains; therefore the data gathered from an examination of the East Mill Creek to Wandamere slope may be safely assumed to apply in a general way to the entire valley.

As shown by the berry vines and tree fruits, the East Mill Creek springtime is on the average about 2 weeks in advance of the season of the lower neighbor, Wandamere. This anomaly exists primarily because the growth of vine and tree crops is dependent principally on the temperature of the atmosphere, and not so much on the temperature of the soil. But fundamentally this dissimilarity in climate has its birth in the nightly transference of air from the mountains to the valley by air drainage.

The draining of the cool air nightly into the Wandamere bottoms causes the accumulation of spring temperatures to lag; that is, the mean temperature for the 24 hours is lower than at East Mill Creek. This condition causes an appreciable lethargy in the opening of the fruit and berry blossoms at Wandamere, and the orchards at East Mill Creek, which lie well above the level to which the cold imported air usually rises, get an average of two weeks' start, because their night-time temperatures average higher, thus giving a greater accumulation of growing temperatures in the same length of time.

#### RANGE OF TEMPERATURE.

The height to which the accumulated cold air extends up the slope each night varies constantly, probably ranging from an inappreciably small distance to as far as the East Mill Creek district itself under favorable conditions; therefore orchards along the slope between show progressively and quite regularly the change from the Wandamere to the East Mill Creek conditions. The slope is a very gradual and even one, therefore the 200-foot rise, representing two weeks difference in the seasons, may be fairly accurately divided into units of one day earlier for fruit for each 14 feet of rise from Wandamere toward East Mill Creek.

The daily march of normal temperatures in the spring at Salt Lake City is at the rate of about  $1^{\circ}$  F. rise in every three days; and from this information the direct deduction is made that the 14-foot rise in elevation, equaling one day's advance in fruit growth, is therefore equivalent to one-third of a Fahrenheit degree increase in the daily mean temperature. The total difference in the daily spring mean temperatures between East Mill Creek and Wandamere, calculated on this basis, is, therefore,  $4\frac{2}{3}^{\circ}$  F.

Thus from this natural necessity the lowlands of the Salt Lake Valley are devoted almost exclusively to truck, vegetable, and hay fields, while the higher slopes are placarded with fruit orchards of every description, interspersed with berry vines.

The flowing of the cold air into the valley from the mountain tops often causes fogs in the valley, especially in the wintertime, when snow covers the ground, serving to maintain a higher humidity; and when seen from above, this fog picture is a very interesting sight, before the morning sun eats its way through to the land beneath. Above the fog the atmosphere is usually perfectly clear, the upper surface of the fog being as sharply marked as are the outlines of a low cloud. (Pl. XXIII, fig. 1.)

On such nights observations at various places in the Salt Lake and other valleys show that temperatures are practically the same at similar altitudes over all parts of the valley. The air in the valley assumes a stratified formation, the colder layers at the bottom and the warmer layers at the top extending entirely across the valley, as is indicated by the fog stratum which spreads from mountain to mountain.

#### AIR CURRENTS.

The streams or currents of air that are caused by gravity to flow down the canyons and slopes at night range in velocity from a very faint movement to a veritable blast which begins light at sunset and increases to a gale by morning, depending on the length of the canyon drainways, the area in the mountains that may drain through the canyon, and the size of the valley below to receive the down-coming air. Mountain orchards are mostly located on slopes where the breezes are light, yet strong enough to be certain of regular occurrence. However, many good bearing orchards are located in the paths of breezes so strong and regular on steep slopes that every tree in the orchard is caused by the wind to lean away from the canyon mouth at an angle of several degrees. This condition is sometimes the cause of a loss of fruit before gathering time from winds alone; but the winds have the compensating good effect of permitting the fruit buds to form in the first place in the early

springtime, while other orchards in quiet places are being damaged by the frost.

An instance occurs near Mapleton, Utah, which is probably not at all an unusual one, where Prof. L. M. Gillilan's Maplewood cherry farm usually bears fruit in safety because of correct canyon air drainage, and which is protected from the occasional violent canyon breezes by being situated on a shelf or ledge at the extreme upper edge of the agricultural section of the valley, yet just a few yards beneath the outlet floor of Maple Canyon, so that all hard winds flow over or above this orchard, leaving it in quiet and safety, while trees below in the lower portion of the valley often have a windfall of fruit due to the stream of air which can be distinctly heard whirring along above the Maplewood cherry farm. These conditions occur when an autumn high-pressure region is so situated as to drain into an adjacent low-barometer area, and cause winds directly through the canyons in question. (Pl. XXIII, fig. 2.)

#### A STRIKING EXAMPLE.

Another interesting natural phenomenon occurs at the outlet of Spanish Fork Canyon (the route of the Denver & Rio Grande Railroad), where there are several hundred acres of good soil lying in a most delightful temperature and precipitation climate that does not even grow good pasturage because of the strong canyon winds, yet this region is surrounded by as fine orchards and farms as are found anywhere in the West. This canyon is long and drains a large, high region from the mountains out onto the broad, open Utah Valley, and the winds run at velocities estimated at from 30 to 50 miles per hour at the canyon's mouth all night long, even in bright, fair weather, when the surrounding regions are resting in comparative quietude.

Orcharding has been and is being tried there in a limited way, but so far has not appeared to be profitable. The scanty vegetation that gets hold on this region leans far out toward the valley and appears to have foliage on but one side of the short stems. A house was once built on this bench, but it was blown from its foundation one clear night. This wind flat is a delta from Spanish Fork River which was formed in prehistoric times on the shore of Lake Bonneville; Spanish Fork town, located just beyond and beneath this bench, from 40 to 60 feet lower, enjoys a splendid climate and is protected admirably from frosts by a reasonable amount of wind.

These canyon breezes are the one great primary problem of the frost fighter, and while fighting frost with fire had its beginning in the favorably situated, mountain-protected orchard, it has also had

its finish in the other mountain orchard that is fanned nightly by a 15 or 20 mile breeze which carries the smoke and heat away in a very thorough manner. And even where the smoke and heat are not carried away so completely, the heating problem varies in intricacy with the wind velocities prevailing.

#### CONCLUSION.

Thus we find that the mountains are often perfect barriers against evil climatic influences and often actually augment and multiply the influences for good. The bugaboo of a treacherous, stormy, frigid, or furnace-like climate has receded far beyond the regions of agricultural possibilities and up into the very mountain tops to remain forever.

# INSECTS INJURIOUS TO THE ONION CROP.

By F. H. CHITTENDEN, Sc. D.,

*Bureau of Entomology.*

## INTRODUCTION.

The onion and other bulb crops of similar structure are very seriously affected by insects when growing in the field. About six species of plants are included in this group—the common onion, Welsh onion, leek, garlic, chives or sives, and shallot. Of these only the common onion is grown to any extent in North America. Comparatively few insects appear to be especially attached to onions, but of these several are very important pests. All are of foreign origin. The list includes forms such as the onion thrips, the root maggots, and such general pests as cutworms, army worms, wireworms, white grubs, and a few other species such as the strawberry thrips. Those listed as general pests are all more or less omnivorous. Doubtless were it not for the pungent odor of the onion and its kind it would be resorted to for food by many insects other than those which have been mentioned. The most important of all of these insects is the onion thrips (*Thrips tabaci* Lind.).

A census of the years 1908, 1909, and 1910 shows a steady increase in acreage devoted to onion growing in different regions. In one centered about Stark County, Ind., the increase has been great. In 1910, 1,500 acres were planted to this crop, and in spite of serious injury sustained from the thrips and some other insects the growers realized such a high percentage of profit that the following year the acreage was doubled. As an example of the profit from onion growing in this region it was claimed by one prominent grower who farms in Indiana as well as in Illinois that his income on onions was 15 times as great as on wheat and corn. The damage due to the onion thrips in the Stark County (Ind.) region was estimated at \$54,000 in 1910, and with double the acreage for 1911 this would have caused a loss of \$108,000 for this region alone. Fortunately, however, this loss was not realized, since the insects were not so numerous as in the previous year.

## THE ONION THRIPS.

(*Thrips tabaci* Lind.)

Our most serious onion pest is of almost microscopic dimensions, generally known as the onion thrips or "thrip." It is also called the

“onion louse.” It causes injury to the onion crop practically throughout the country, producing a condition somewhat generally known as “white blast,” “white blight,” and “silver top.” It is also the cause of “scullions,” or “thick-neck”—undeveloped and unmarketable bulbs. In aggravated cases whole fields, and sometimes large areas, are rendered unproductive, and in extreme cases are completely destroyed. The whitened appearance of the onion leaves and tops is due to the extraction of the vital juice, first by rasping, followed by suction. In a short time after attack begins the leaves become peculiarly curled, crinkled, and twisted, and finally die down prematurely. (See Pls. XXIV and XXV, showing the difference between normal and thrips-infested onions.)

The importance which this thrips has assumed since about 1904 is such that a considerable proportion of those who have been engaged in investigation of truck-crop insects in the Bureau of Entomology have devoted more or less time to its investigation and in the practical application of remedies. This work has to date cov-

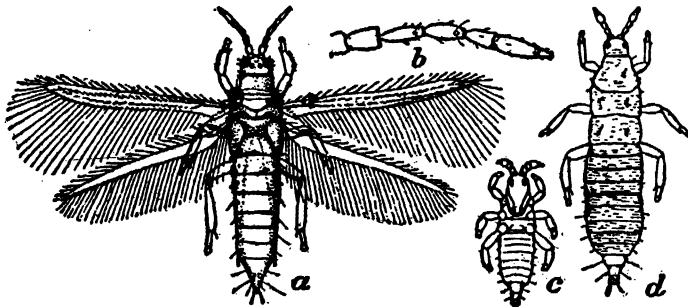

FIG. 1.—The onion thrips (*Thrips tabaci*): *a*, Adult; *b*, enlarged antenna of same; *c*, small nymph; *d*, older nymph. All enlarged. (Reengraved after Howard.)

ered five years. The principal work in the field has been done by Mr. H. M. Russell in Florida, by Messrs. D. K. McMillan and H. O. Marsh in Texas, by Mr. Marsh in Colorado, and by Mr. M. M. High in Texas and Indiana.

#### DESCRIPTION.

The general appearance of both sexes of this thrips, which are very similar, is shown in figure 1, *a*, highly magnified. The adult insect is pale yellow in color, with the thorax somewhat darker. The wings are still paler yellow, with dusky fringes and bristles. A full-grown nymph or larva is shown at *d*, and a younger one at *c*. The egg is bean-shaped, semitransparent, and is deposited by the female just beneath the epidermis of a leaf.

#### HISTORY AND HABITS.

Onion thrips may now be found in practically all cultivated fields in the United States, as well as in many uncultivated areas where

suitable food plants for its sustenance are growing, so that there is always danger of infestation to onions and other susceptible crops, whether grown in new or in old land.

Observations tend to demonstrate that in some localities, at least, it makes little difference as to the previous crop. Nevertheless there can be no doubt that, taking the country at large, there is always grave danger of infestation to onion fields where crop rotation is not practiced and where onions follow onions or other susceptible plants, and where culls and other refuse from onion beds are allowed to accumulate in and near fields to be replanted in onions.

There is little evidence available that the quality of the soil has in itself much bearing on the degree of infestation.

Owing to the minute size of thrips, it is a matter of some difficulty to investigate their full life histories, and it is particularly difficult to generalize without knowing more of the habits of the important groups. The following, however, is approximate:

The parent thrips is usually found on the lower side of leaves or embedded in flowers. The female, by means of a tiny saw-like organ with which she is provided near the end of the abdomen, cuts a slit, in a leaf or stem usually, and in this deposits an egg, generally inserting it under the epidermis concealed from view. Here the egg hatches in a few days, and the young thrips works its way out and begins to feed. The thrips larvæ suck the juices of the plants in the same manner as do the adults, and, since they feed continuously, their growth is rapid. In one or two weeks, depending upon the temperature, they cease feeding and seek a suitable location in which to transform to the final stage of the nymph and from that stage to the adult. The life cycle from the time of deposition of the eggs until the maturing of the adult has been found to require, under the most favorable conditions—that is, in a warm temperature—about three weeks. Half a dozen or more generations might thus be produced during a season.

It should be added in regard to the life history of this thrips that infestation may be complicated by the attacks of other insects, such as the red spider, when growing in greenhouses (see Pl. XXVI, middle figure) or by cutworms and wireworms in the field (see Pl. XXXII).

#### FOOD PLANTS.

Besides onions and related plants, this thrips attacks cabbage, cauliflower, parsley, cucumber, melon, pumpkin, squash, kale, turnip, tomato, seed beets, blackberry, and strawberry.

Of ornamental plants it does much injury to carnations and roses and more or less injury to aster, blanket flower (*Gaillardia*), honey-suckle (*Lonicera*), daisies, nasturtium, narcissus, mignonette, candy-

tuft (*Iberia*), four-o'clock (*Mirabilis*), and cone-flower or golden-glow (*Rudbeckia*). Very serious injury is frequently committed to

cucumbers and carnations in greenhouses, the damage sometimes amounting to the destruction of entire plantings.

Among field and forage crops, tobacco has been injured by this thrips in Europe, but not in America, so far as we know, and there are records of occurrences on timothy and other grasses, clover and sweet clover, and wheat. It also breeds

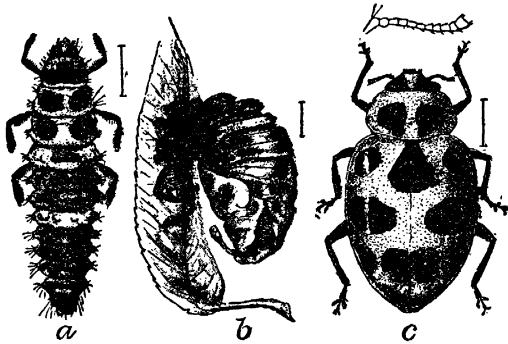

FIG. 2.—The spotted ladybird (*Megilla maculata*): a, Larva; b, empty pupal skin; c, beetle with enlarged antenna above. All enlarged. (Author's illustration.)

on a great variety of weeds, a list of which would fill considerable space.

#### NATURAL CONTROL.

It is well known that rain, and especially sudden and driving storms, frequently destroys great numbers of this insect. This has

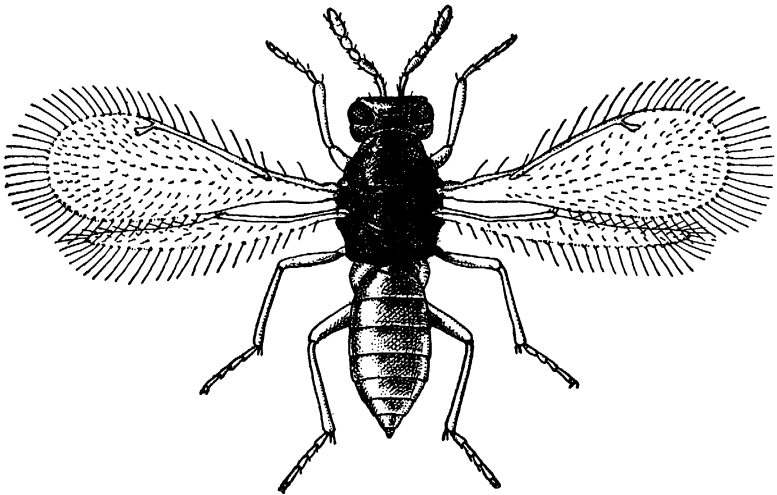

FIG. 3.—*Thripoctenus russelli*. Adult. Greatly enlarged. (From Russell.)

come under the notice of practically everyone who has studied thrips. Among other methods of natural control are ladybirds of several species, the spotted ladybird (*Megilla maculata* De G.) (fig. 2) leading in this respect. About second in importance is the so-called insidious flower bug (*Triphleps insidiosus* Say). There is also a



natural parasite which has only recently been discovered by Mr. Russell, of this bureau. It is known as *Thripoctenus russelli* Crawf. (See fig. 3.) A long list of other insect enemies might be added.

## TREATMENT.

The methods of treating onion fields affected by the onion thrips are complicated. Kerosene emulsion, whale-oil or fish-oil soaps, and tobacco or nicotine extracts are good remedies. Because of their minute size thrips are difficult to reach except in their younger stages; hence remedial measures should be undertaken early in the season to act as preventives rather than cures. The habit of the thrips of concealing themselves in flowers and other parts of plants, such as the sheaths of onion leaves, increases this difficulty.

Too great stress can not be laid on the value of clean methods of field management, as the onion thrips feeds on nearly all vegetables and many flowering plants and is a pest in greenhouses. It develops also on weeds of various kinds. After the onion crop is gathered, useless material—culls, tops, and injured plants (see Pl. XXVIII, fig. 2)—should be promptly destroyed by burning and not left where the insects can spread to neighboring plants, to reinfest onions or other susceptible crops when these are planted the following season.

Early planting is of service, especially northward. Manure and other fertilizers should be freely used to stimulate early growth. Plate XXVIII, figure 1, shows the age at which onions are usually first attacked by migrating thrips.

With an insect capable of sustaining life on such a variety of vegetation, it is difficult to find an alternate crop plant that is not likely to be injured. For alternates, cabbage, cauliflower, strawberry, and cucumber and other curcubits should be avoided; also ornamental plants, particularly roses and carnations, as all of these are much favored by thrips. These plants should not even be grown in the vicinity of onion fields. Certain other vegetables, however, such as potato, sweet potato, peas, beets, and spinach, although they may be attacked by the adults, are not, as a rule, materially damaged.

Onion growers should be able to conduct remedial work with the aid of the instructions herewith, provided they employ the proper sprayers for the purpose. Agents who have been working on the onion thrips for four years past, and especially during the years 1910–1912, met with much success with the nicotine sulphate solutions.<sup>1</sup> The formula first used in 1910 was—

*Formula No. 1.*

Nicotine sulphate .....	10 ounces.
Whale-oil soap .....	5 pounds.
Water .....	50 gallons.

<sup>1</sup> Where nicotine sulphate is mentioned in the formula a solution containing 40 per cent nicotine is understood.

Afterwards it was ascertained by Mr. M. M. High, working in Texas and Indiana, that the solutions that have been most successfully used are formulas No. 2 and No. 3.

*Formula No. 2.*

Nicotine sulphate.....	3.2 ounces.
Cresol soap.....	3 pints.
Water.....	50 gallons.

*Formula No. 3.*

Nicotine sulphate.....	4.3 ounces.
Whale-oil soap.....	4 pounds.
Water.....	50 gallons.

In the case of formula No. 2 some time is saved because it is not necessary to dissolve the soap, it being a liquid. With No. 3 the whale-oil soap must be shaved into small particles and heated before a solution is formed. Where a semiliquid or "potash" soap is used, this difficulty is not encountered. The cresol soap is somewhat the better as a "spreader," but should be purchased with care and the correct strength obtained (85 per cent cresol soap) in order to secure the best results. A good quality of whale-oil soap gives good results, and it is only a question as to which soap is more available on the instant needed and how valuable time is with the grower. When spraying is once begun it should be continued at intervals of from 7 to 10 days, in case there is no heavy rainfall during this period, and no surrounding breeding host for the species. The spraying should, as a rule, be continued up to 3 or 4 weeks of harvest time.

In spraying for thrips the nozzles should be held well down upon the plants and the spray applied with as much force as possible. The addition of soap is chiefly for action as a spreader and as a "sticker" or adhesive, and the nicotine acts better at this strength. It does not adhere to the plants when used alone. The soap is also insecticidal.

Plants sprayed with nicotine sulphate combination present a striking contrast to those which are not so treated. In Maryland, near the District of Columbia, a single spraying of nicotine sulphate gave similar results, the plants doing better and the insects being killed to a larger extent than by the use of other insecticides. Kerosene emulsion has sometimes proved a failure in Colorado and elsewhere and is, moreover, difficult to make with hard or alkaline water. Experiments with other nicotine solutions, 1 part to 128 parts of water, gave in one case as high as 86 per cent of young thrips killed.

The practice of growing onions by starting them in sets is one of the chief causes of early injury by the onion thrips. Considerable

injury, however, may be prevented by dipping the sets, about a week before planting, in nicotine sulphate at about the same strength as is used in spraying, and then giving two dippings in the same insecticide

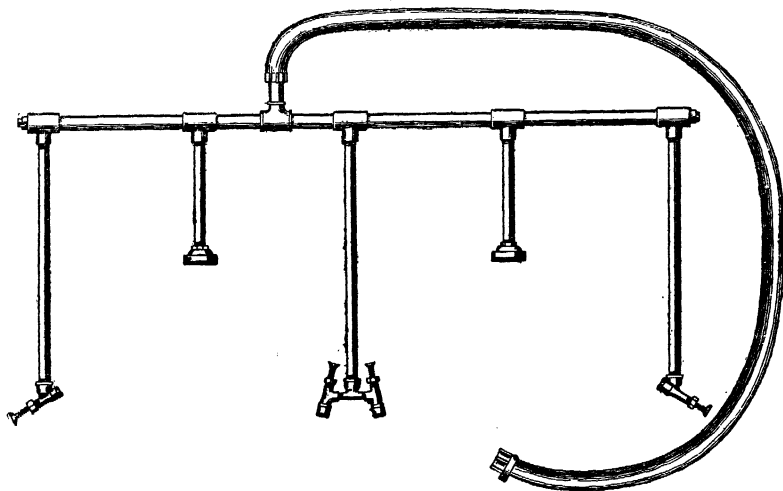

FIG. 4.—Two-row arrangement of nozzles, ready for spraying onion thrips. Reduced. (Original.)

at planting time, or in almost any other of the solutions which have been mentioned, including kerosene emulsion.

Knowing the preference which the onion thrips displays toward cabbage and cauliflower, neither of these two crops should be grown contiguous to onions. Plate XXVII, figure 1, shows plainly the

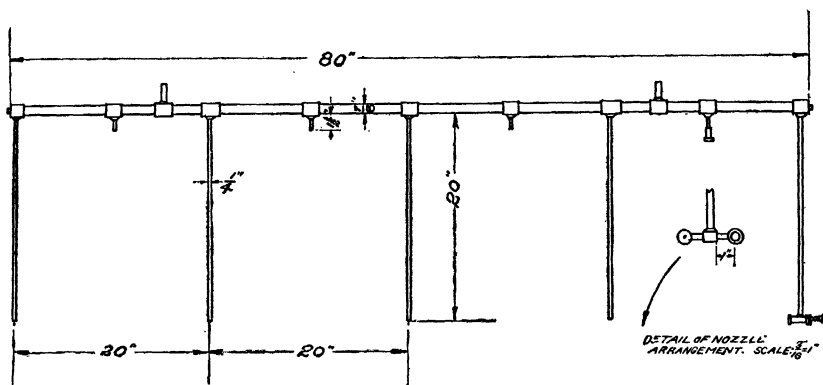

FIG. 5.—Four-row attachment for onion sprayer. (From Marsh.)

undesirability of this, as each serves as a breeding place for the onion thrips, and if the thrips first attack the onions they will pass over to the cabbage fields adjoining. Such combination will prove, other things being equal, that the thrips will have abundant opportunity for wintering over to attack the early plants of the next year.

A high-growing crop like corn may be used as a protection for a field of onions from another field infested by the thrips.

The value of irrigation and the use of other remedies are shown in illustrations which follow.

Plate XXVII, figure 1, is a good illustration of the tops of onions nearly dead (at the left) and the thrips migrating, feeding, and spreading to the adjoining cabbage and shows the undesirability of growing onions alongside of cabbage.

The question of the best spraying machines, nozzles, and other portions of an outfit for use on onion fields has not been quite satisfactorily solved. What will do well in one district may not be so efficient in another. Plates XXIX and XXX, figure 1, illustrate a single horse or mule hand-sprayer used at Rocky Ford, Colo., by Mr. Marsh, which has been found by him the most suitable for use against the onion thrips in that locality, while Plate XXX, figure 2,

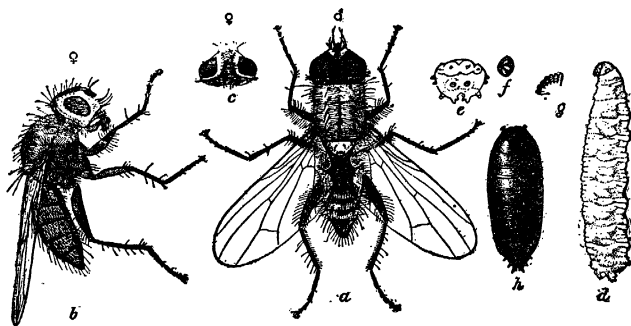

FIG. 6.—Seed-corn maggot (*Pegomya fusciceps*): a, male fly, dorsal view; b, female, lateral view; c, head of female from above; d, larva, from side; e, anal segment of larva; f, anal spiracles; g, cephalic spiracles; h, puparium. All much enlarged. (Author's illustration.)

a two-horse power-sprayer, is shown in operation against onion thrips, with nozzles properly held. This was used successfully by Mr. High in Texas.

Two-row and four-row attachments for an onion sprayer are shown in figures 4 and 5, and the types of nozzles most suitable for use on an onion sprayer in Plate XXVII, figure 2.

#### ROOT MAGGOTS.

Several forms of root-feeding maggots have a special tendency to attack onions; some of them, however, are general feeders. The imported onion maggot (*Pegomya cepetorum* Meade) is very destructive to nearly all forms of the onion family. Nevertheless there are quite as many, if not more, records of the seed-corn maggot doing the more abundant injury to onions, as well as to root crops in general and to many seeds.

## THE SEED-CORN MAGGOT.

*(Pegomya fusciceps Zett.)*

The seed-corn maggot (*Pegomya fusciceps* Zett.) has been so named because it was first observed attacking the sprouting seeds of corn, but it often attacks onions and cole crops, working in the roots and stalks beneath the earth's surface. When seeds are found which fail to develop, the grower, if careful, will discover a small white maggot of this species or of the related cabbage maggot. It is about equally injurious to beans and has been named the "bean fly." Other plants which it particularly injures are cabbage, turnip, radish, peas, beets, seed potatoes, and many others. The insect has been introduced from abroad and is well diffused throughout the United States, from Maine to Washington State and southward. It resembles the common house fly very much in appearance. It is evident that this species, since its first coming into prominence, in about 1902, although known here many years before, is greatly on the increase.

In its earlier stage the seed-corn maggot resembles the house fly. The maggot is footless and cylindrical, presenting in profile the appearance of the letter *d*. It measures, when clear, about 0.25 inch in length and about 0.04 inch in width. The color is pale yellowish or white. The maggot transforms to a dark larval puparium, shaped as shown in figure 6 at *h*. The difference between the sexes is quite prominent, as evidenced by figure 6, *a* and *c*.

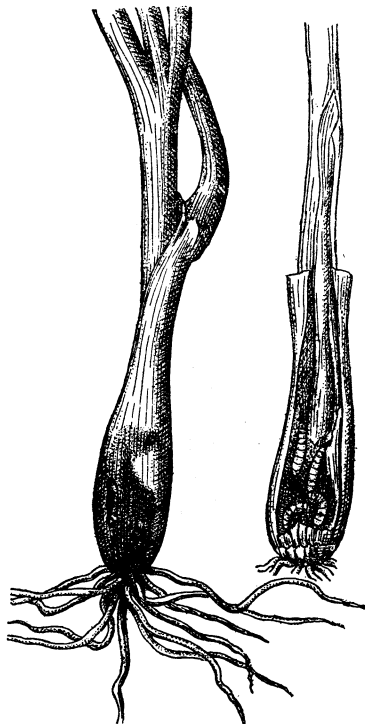

FIG. 7.—Young onion plant, showing imported onion maggots at work in the bulb; at right, plant exposed slightly, showing the same. (Original.)

## THE IMPORTED ONION MAGGOT.

*(Pegomya cepetorum Meade.)*

The imported onion maggot is nearly as troublesome in the northern belt as is the seed-corn maggot. Its injury, which constitutes a very important drawback to the culture of onions, is accomplished

by the consumption of the bulb (fig. 7), inducing subsequent decay of the affected portions and their very frequent destruction.

The fly (fig. 8, *a*) and the maggot resemble the preceding species, although their average size is a little larger. The length of the fly's

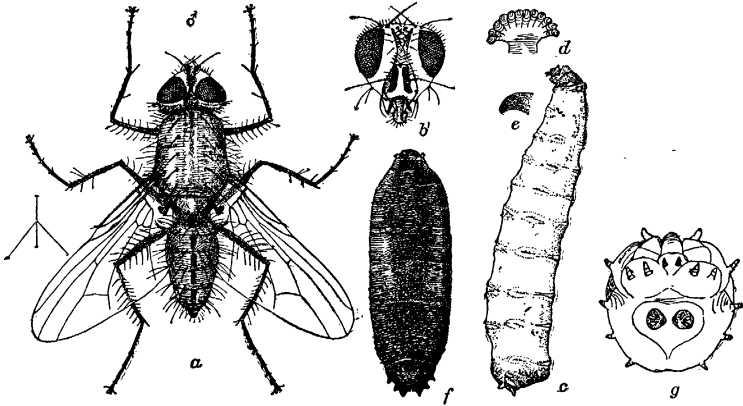

FIG. 8.—Onion maggot (*Pegomya cepetorum*): *a*, Male fly; *b*, head of female; *c*, larva; *d*, prothoracic spiracles of same; *e*, cephalic hook of same; *f*, puparium; *g*, anal extremity of larva. All much enlarged. (Original.)

body is about three-sixteenths and the wing expanse nearly three-eighths of an inch. The male is gray, with black bristles and hairs; he has a white face with black hairs, and there are three dark lines on the body between the wings and a row of black spots on the abdomen. The female is a little the larger, and inclined to dark

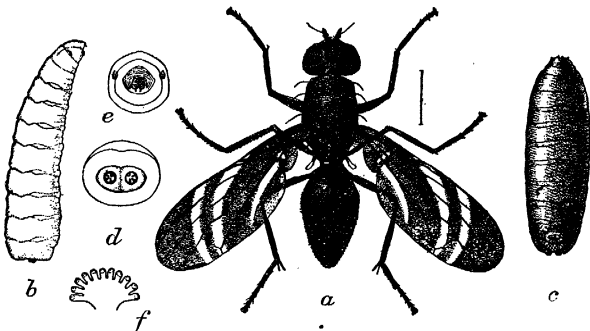

FIG. 9.—Black onion fly (*Tritoxa fleaa*): *a*, Fly; *b*, larva; *c*, puparium; *d*, anal extremity from below; *e*, cephalic extremity, face view; *f*, cephalic spiracles.

yellowish, with a pale yellowish face. The other stages, with particulars, are also illustrated by figure 8.

Two or three generations annually are evidently the rule.

The methods of control prescribed for maggots in general (p. 331) are about all that are necessary for this species. In case of severe



NORMAL ONION PLANTS GROWN IN LARGE POT TO PREVENT INFESTATION BY THRIPS IN VICINITY. (ORIGINAL.)



INFESTED ONION FIELD, SHOWING DEFECTIVE BULBS COMPARED WITH NORMAL BULB. REDUCED. (ORIGINAL.)



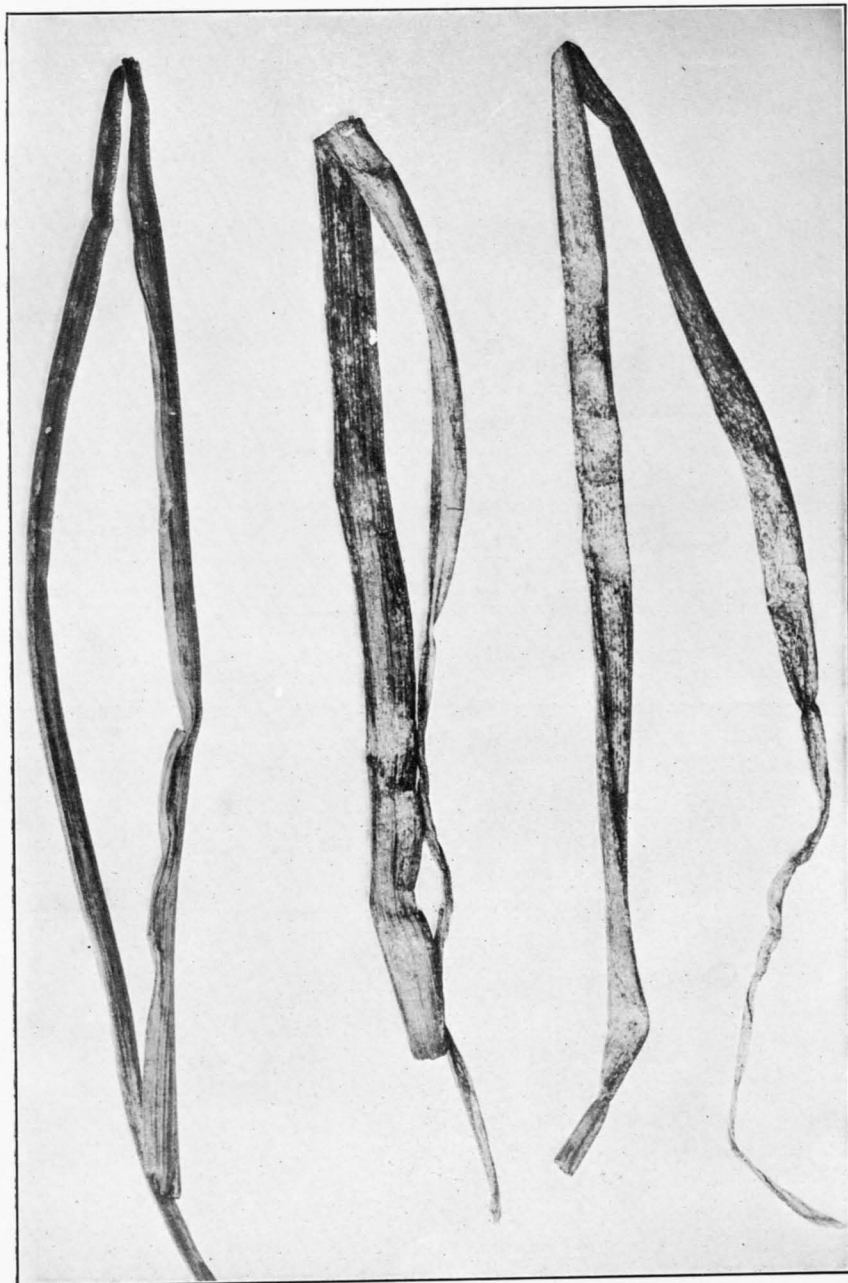

ONION LEAVES SHOWING INJURY BY ONION THRIPS AT RIGHT, UNINJURED LEAF AT LEFT, AND LEAF INJURED BY RED SPIDER AT MIDDLE. (ORIGINAL.)



FIG. 1.—ONION AND CABBAGE FIELDS ADJOINING, EACH SERVING AS A BREEDING PLACE FOR ONION THRIPS. \* (ORIGINAL.)

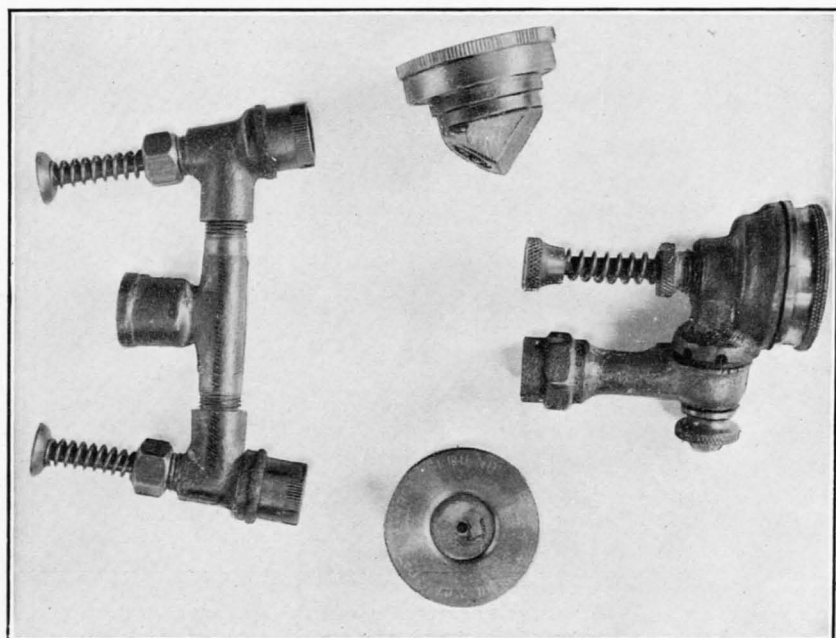

FIG. 2.—TYPES OF NOZZLES USED IN SPRAYING FOR THE ONION THRIPS. REDUCED. (ORIGINAL.)



FIG. 1.—ONIONS WHEN FIRST INFESTED BY MIGRATING THRIPS IN JUNE. (ORIGINAL.)



FIG. 2.—ONIONS IN CRATES, WITH THE TOPS LEFT IN PILES HIGHLY INFESTED WITH THRIPS EGGS AND ADULTS. (ORIGINAL.)



TWO-ROW FIELD SPRAYER USED AGAINST THE ONION THRIPS. (ORIGINAL.)



FIG. 1.—TWO-ROW FIELD SPRAYER IN ACTION AGAINST THE ONION THRIPS. (ORIGINAL.)

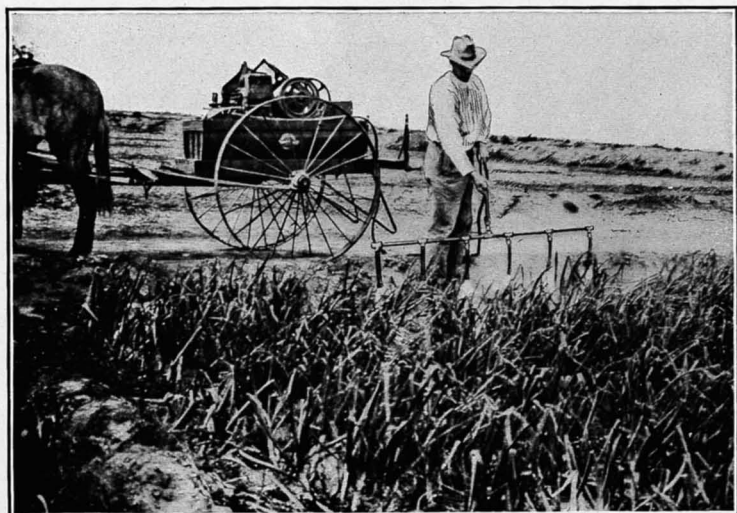
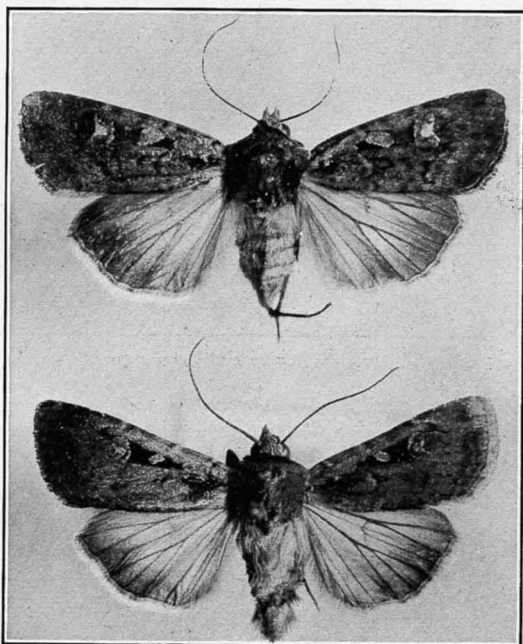

FIG. 2.—POWER SPRAYER IN OPERATION AGAINST THE ONION THRIPS, THE NOZZLES PROPERLY HELD. (ORIGINAL.)



CUTWORM MOTH.

[The form shown below is one of the commonest forms of *Euxoa*, known as *E. tessellata*. The upper form is known as *E. punctigera*. Enlarged. (Original.)]





ONION PLANT FROM KNOX, IND., SHOWING SO-CALLED PATHOLOGICAL CONDITIONS AFTERWARDS FOUND TO BE DUE TO WORK OF WIREWORMS AT ROOTS. REDUCED. (ORIGINAL.)

infestation other remedies might be necessary. The flies are probably attracted to old onion beds and to crop remnants; hence clean field methods are advisable.

THE BLACK ONION FLY.

(*Tritoxa flexa* Wied.)

The black onion fly (*Tritoxa flexa* Wied.) has been noted as an enemy to onions as early as 1865, which fully accounts for its ravages. The probabilities are that it is often confused with the other two species which feed on onions, *Pegomya fusciceps* Zett. and *Pegomya brassicae* Bouché, as it is likely to be mistaken for them unless a strong lens is employed. The fly was given its scientific name by Wiedemann in 1830. Its injury to onions in this country was first noted in Illinois. Unlike most of the other species, it is native and is recorded as occurring in New Jersey, Ohio, Illinois, Pennsylvania, and Minnesota. It is evidently nearly restricted to the Northern and Middle States, and no injuries have been observed in New Jersey to the writer's knowledge. The adult belongs to the family Ortalidæ. It is almost entirely black, with the exception of three narrow, oblique, hyaline white stripes on each wing. The body is slender, as are also the legs, head, and eyes, the latter being somewhat prominent. The fly measures fully one-third inch in length and has a wing expanse of one-fourth inch. Its appearance is sufficiently indicated in figure 9, at *a*, the larva at *b*, and the pupa at *c*. The cephalic tubercles shown at the apex number 11. This species differs practically from the others which have been and will be mentioned by the fact that it continues to live in onions in storage, and also that it appears to be restricted to this plant, with the possible exception of garlic.

In regard to remedies, it is reported that water applied boiling hot to the young onion plants will destroy the maggots without harming the plants. Another suggested remedy is the pulling up of affected plants when, from their drooping state, it becomes manifest that maggots are at work in their bulbs, the pulled plants to be promptly destroyed by burning.

Although no test of remedies has been found possible in this bureau, we can conveniently assume from analogy that remedies advised for root maggots (p. 331) will be found of value. When the insects are attacking stored onions bisulphid of carbon can be used as a fumigant.

THE BARRED-WINGED ONION FLY.

(*Chætopsis anea* Wied.)

The barrel-winged onion fly is evidently, like the seed-corn maggot, a species which may breed normally in decomposing vegetation, but



which at times, and less frequently than in the case of the species just cited, is injurious to useful crops. Its first identification with injury was to oats in Ohio in 1886. It is frequently associated with injuries by other species, following the attack of more injurious insects, such as the sugar-cane beetle<sup>1</sup> in corn and cane. Until a decade ago (1902) known injury was confined to cereals, including wheat, but during 1899 onions were considerably injured by this maggot in southern Michigan.<sup>2</sup> One grower at Climax, Mich., composted 700 bushels of onions because of the ravages of this insect. His entire crop for 1900, amounting to 2,000 bushels, was destroyed, and he was obliged to abandon onion raising for a time. Other onion growers in that region experienced similar trouble with this pest.

This species belongs to the dipterous family Ortalidæ. The adult is a common, metallic, grayish-black, two-winged fly, with the wings banded. The larva is whitish or yellowish and measures about five-sixteenths of an inch in length; and the puparium is darker, polished brown in color.

The insect ranges from Canada on the north to Cuba and the Bermudas in the south, and from the Atlantic to the Pacific.

The eggs have been observed in central Ohio during the second week of May, and, according to the observations of Mr. W. B. Alwood, they are inserted just under the edge of the leaf sheath in groups of from two to five, and sometimes singly. The egg is pearly white, five times as long as wide, and tapers to a point at each end.

As soon as the maggots are hatched they distribute themselves under the sheath, sometimes to the number of 10 or 15, thus exhausting the juices of the plant, the outer leaves becoming brown and seared, after which the whole stalk finally withers away. Here they transform to puparia and in due time issue as adults.

The observations conducted on this insect by Prof. R. H. Pettit in Michigan show that the maggots pass the winter inside of the onions, and since adults are to be seen at widely different seasons this affords evidence that the insect, like other root-feeding maggots, may produce several generations annually.

The remedies mentioned as of greatest value in the treatment of maggots in general (p. 331) are indicated for this species. As soon as plants show infestation they should be pulled up and destroyed. The fact that hibernation takes place inside the onions makes it desirable to destroy, in the fall, all onions too much injured for food, and to disinfect the better ones with bisulphid of carbon.

<sup>1</sup> *Ligyus rugiceps* Lec. See article, *Insect Life*, Vol. VII, pp. 352-354, 1895.

<sup>2</sup> R. H. Pettit, *Bul.* 200, Mich. State Agr. Exp. Sta., pp. 206-208, 1902.

## REMEDIES FOR ROOT MAGGOTS.

Owing to the difficulty of destroying root maggots and other subterranean pests and the cost of chemicals for the purpose, growers depend largely upon methods of prevention. To be thoroughly effective these methods should be employed *before the fly's eggs are laid*.

A common method for deterring the parent flies from depositing eggs consists in placing sand soaked in kerosene—a cupful (6 fluid ounces) to a bucket of dry sand—at the base of the plants, along the rows. This mixture will also kill young maggots attempting to work through it.

For all forms of root maggots which we are considering a carbolized form of kerosene emulsion is effective. This is prepared by adding to 1 pound of soap, boiled in 1 gallon of water, one-half gallon of crude carbolic acid, and diluting the whole with from 35 to 50 parts of water. This mixture is applied about the stalks of the plants affected. It is best to use it a day or two after the plants are up, or are transplanted, and to repeat every week or 10 days until about the third week in May in the North. Farther south these applications must be made earlier in the season.

Mineral fertilizers are useful as deterrents, particularly when employed just before or after a shower has thoroughly wet the ground. The principal fertilizers for this purpose are kainit, nitrate of soda, and sulphate or chlorid of potash. They may be used as top dressings before planting, or if not employed until afterwards they should be applied as nearly as possible to the roots, the earth being turned away from the plants for this purpose. These fertilizers, also, by stimulating plant growth, facilitate recuperation from root-maggot attack.

There is great danger in the use of other fertilizers, such as stable manure, cottonseed meal, and organic fertilizers comprising moldy leaves, dead plant life, and even fish scrap. In an account of this species published several years ago the writer stated that numerous instances had come to his notice—and still more noticeable instances have accumulated lately, and a long list could be furnished—where the presence of the insect could be traced to the causes above mentioned. It is advisable, therefore, to avoid the use of manure of any kind, rotted leaves, or other organic fertilizer, and, above all, to avoid further planting in fields which have been infested or contain diseased onion plants, or where cabbage, cowpeas, or any other plants have been turned under.

As soon as seed fails to appear at the proper time or the plants show signs of wilting and maggots are found to be present, the seed

may be hoed out or the injured plants pulled and destroyed, together with the younger maggots.

Most of the methods mentioned above have been used with success against onion maggots and other root-feeding species, and are all that are required in many cases of ordinary infestation of vegetable roots.

Other remedies have been tested; mostly, however, without avail.

#### CUTWORMS.

Onions are subject to serious attacks by certain cutworms. These appear sometimes in great numbers in spring and early summer and frequently do severe injury before their ravages are noticed. Their method of attack is to cut off young plants at about the surface of the ground, and as cutworms are voracious feeders, they may destroy many plants in a single night, frequently more than they can devour. During the past two years these insects, working generally throughout the United States, destroyed hundreds of thousands of dollars worth of crops. By the timely application of remedies in some of the principal trucking regions, e. g., in southern Texas, in the vicinity of Rocky Ford, Colo., in California in the vicinity of Sacramento, in Stark County, Ind., and in some other regions, these insects were readily controlled, large areas being successfully treated.

Of the cutworms which were most injurious in Stark County, Ind., the most abundant in 1911 was *Euxoa punctigera* Walk. Of other species, *Euxoa tessellata* Harr. and *Euxoa messoria* Harr. occurred in about equal numbers but were not so numerous as the one first mentioned. The last is called the dark-sided cutworm, and has been an important onion pest, to our knowledge, since 1885. Another very injurious species in some years is the variegated cutworm (*Peridroma margaritosa* Haw.). No very careful attention has been paid to the principal species injurious to onions in other regions. There is perhaps a slight difference in the habits of all of these species in regard to the time of attack. The adult, or moth, of *Euxoa punctigera* is shown in Plate XXXI, above, and the adult of *Euxoa tessellata* in the same plate, below.

The usual method of control is by the use of poisoned baits. To a bushel of bran 1 pound of arsenic or Paris green is added and mixed thoroughly into a mash with 8 gallons of water, in which has been stirred half a gallon of sorghum or other cheap molasses. After the mash has stood several hours it should be scattered in lumps of about the size of a marble over the fields where injury is beginning to appear and about the bases of the plants set out. It should be applied late in the day, so as to place the poison about the plants over night, which is the time when the cutworms are active. The application should be repeated if necessary.

When cutworms occur in unusual abundance, which happens locally, and sometimes generally in some seasons, they exhaust their food supply and are driven to migrate to other fields. This they do, literally in armies, assuming what is called the army-worm habit. At such times it is necessary to treat them as army worms. While the methods which have been advised are valuable in many cases, they may be too slow to destroy advancing hordes of cutworms, and other methods must then be employed. These include trenching, ditching, the plowing of deep furrows in advance of the traveling cutworms to trap them, and the dragging of logs or brush through the furrows. If the trenches can be filled with water, the addition of a small quantity of kerosene, so as to form a thin scum on the surface, will prove fatal. In extreme cases barriers of fence boards are erected and the tops smeared with tar or other sticky substance to stop the cutworms as they attempt to crawl over.

Clean cultural methods and rotation of crops are advisable, as also fall plowing and disking. Many cutworms can be destroyed where it is possible to overflow the fields. This is particularly applicable where irrigation is practiced.

Cutworms caused considerable damage to onions in northern Indiana in 1911 and 1912 just after the plants had emerged from the soil. In the sections where injury was greatest the growers were no more familiar with the cutworm problem than with the culture of onions—this being their first year in growing this crop for market. In the regions where onions were grown previously the cutworms were prevalent also, but were controlled by the use of the bran-mash bait that was used so successfully last year in the same fields. About 1,000 acres were treated for cutworms by the use of the bran mash, the formula being as before, 1 pound white arsenic, 1 bushel bran, and from  $\frac{1}{2}$  to 1 gallon corn sirup with enough water for moistening. Some used Paris green instead of the white arsenic and obtained excellent results. Some growers suffered a loss of from one-third to one-half of their crops from cutworm ravages alone. This could have been averted by the use of the bran mash in time.

#### WIREWORMS.

The term "wireworm" is applied to numerous forms of elongate wirelike creatures, the larvæ of snapping beetles or "snap bugs,"<sup>1</sup> and is given them because of their firm texture, so different from that of many insect larvæ.

There are many species of these insects and quite a number of them have shown some preference for onions. More often, however, they do their greatest damage to truck crops following land which has

<sup>1</sup> Coleoptera, family Elateridæ; genera *Drasterius*, *Melanotus*, *Cardiophorus*, et al.

been in grass or meadowland. One of these species, known as the wheat wireworm (*Agriotes mancus* Say), has been found very injurious to onions in Stark County, Ind. It is shown in figure 10 about four times natural size. The life histories of the different genera have not been thoroughly worked out. Wireworms injure plants by the destruction of the roots and are very difficult to treat satisfactorily. Among direct applications some forms of salts and even brine, not too strong, have been used successfully in some regions. Salty fertilizers, such as kainit and nitrate of soda, are of value. (See p. 331 for discussion.) Clean cultivation, crop rotation, and poison baits, the latter discussed on page 332, are always to be recommended, as for cutworms. According to recent observations made by Mr. J. E. Graf on the sugar-beet wireworm in California, clean culture against the adults, compelling them to seek shelter elsewhere and exposing them to the attacks of their natural enemies such as birds, appears to be for that species the most practicable remedy, the efficiency of which may be in-

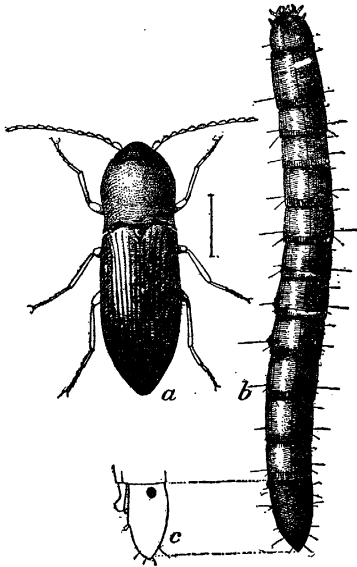

FIG. 10.—The wheat wireworm (*Agriotes mancus*): a, Beetle; b, larva; c, anal segment of larva in profile. About four times natural size. (Author's illustration.)

creased by fall plowing and early planting.

In Plate XXXII an injured onion plant is illustrated to show so-called "pathological conditions," found afterwards to be due to wireworms at the roots.

#### OTHER INSECTS.

Onions at present are little injured by insects other than those which have been mentioned in the foregoing columns. We might add such common pests, however, as the tarnished plant-bug, some forms of true bugs, and the strawberry thrips. The last-mentioned has, however, been frequently misquoted in mistake for the onion thrips, the two species being quite different.

## CONDENSED AND DESICCATED MILK.

By LEVI WELLS,

*Dairy Inspector, Dairy Division, Bureau of Animal Industry.*

### INTRODUCTION.

Milk is a bulky product, expensive to transport, and very susceptible to contamination, which in a short time renders it unpalatable. In its natural state it contains about 87 per cent of water, which is a comparatively worthless constituent.

Efforts to reduce the water content of milk, leaving the solids in a more concentrated form without destroying their food value, and at the same time improving the keeping qualities, have resulted in developing the manufacture of both condensed milk and desiccated milk or milk flour. The condensing processes now used reduce the volume of milk to one-half or one-fifth its original bulk, and if the product is carefully sterilized or preserved with cane sugar and sealed in air-tight containers it becomes easily transportable and keeps for long periods in any climate.

The desiccating processes now perfected remove practically all the water in milk, leaving a dry powder soluble in water. In the manufacture of this product whole milk is reduced to about one-eighth, and skimmed milk to about one-eleventh the original volume. By this means the volume is reduced to a minimum, and the keeping quality, particularly of dried skim milk, is superior.

### CONDENSED MILK.

Removing a portion of the water from milk, leaving a product of good keeping quality which may be restored to its normal consistency without injuring its natural flavor, is a problem that has been studied for many years. It is claimed that during the first half of the last century foreign inventors evaporated a part of the water from milk, and, with the addition of cane sugar, made what was then known as condensed milk (see *Scientific American*, export edition, July, 1905). The early patents of De Heine (1810), Newton (1835), and Grimwade (1847) show that much attention was given to the subject before the present generation was born. The successful manufacture of condensed milk on a commercial basis, however, dates from 1856,

when Gail Borden, who has been called the father of the condensed-milk industry, built the first milk-condensing factory at Wolcottville, Conn.

During the last 25 years great strides have been made toward perfecting various processes for successfully producing condensed and evaporated milks. The industry is no longer in its experimental stage, but has reached a point where, with proper equipment and skilled operators, there is no uncertainty about obtaining a satisfactory product. During this time the industry has attained vast proportions, and there are now in this country over 300 milk-condensing plants, located in 24 States, and representing an investment of over \$15,000,000 in buildings and equipment. These plants have a capacity of over 15,000,000 pounds of milk daily. Census reports show that the value of condensed milk made in the United States during the year 1909 was \$33,563,129, and that during the period from 1880 to 1905 the production of condensed milk increased 1,202 per cent.

The term "condensed milk" is generally applied to milk from which a portion of the water has been removed, thus reducing its bulk and weight, and increasing its density and percentage of solids. It is made from whole milk or from partially or wholly skimmed milk, according to the use for which it is intended. In trade circles, however, the term "condensed milk" is applied to milk that is concentrated and preserved with cane sugar. The term "plain condensed milk" is applied to milk that is concentrated and sold in bulk without being sterilized or preserved with sugar, and the term "evaporated milk" is applied to milk concentrated and preserved in cans by sterilization. Evaporated milk contains nothing but normal milk reduced to about one-half of its original bulk, while the sweetened condensed milk contains fully one-third cane sugar. Evaporated milk has, to a large extent, taken the place of sweetened condensed milk.

Before the pure-food laws prohibiting misbranding were in force, unsweetened concentrated milk was frequently labeled "Evaporated cream," but as the product was made from milk and sometimes from skim milk, it was plainly a violation of such laws, and the practice was finally discontinued.

Besides evaporated milk put up in cans, large quantities of plain condensed milk made from skimmed or partially skimmed milk are manufactured. The keeping qualities of this class of goods are about equal to those of pasteurized milk or cream and range from a few days to a week or two, depending on the temperature at which it is held. This product is usually shipped in 40-quart milk cans and is used largely by confectioners and ice-cream manufacturers.

To produce a condensed milk of good flavor and keeping quality the milk to be treated must be of a superior grade. This is so

important that the large concerns engaged in the business employ trained men to examine the herds and ascertain that there are no diseased cows, that the stables and surroundings are in good sanitary condition, that the attendants who do the work are healthy and cleanly attired, and that the milk is properly cared for and cooled before it is delivered to the condensery.

To make doubly sure that the quality of the milk received is right, an expert, with a keen sense of taste, inspects every can of milk received, and if any unnatural flavor is detected the can of milk is rejected and returned to the producer. This extreme care is absolutely necessary, because any objectionable flavor becomes intensified and can not be eliminated during the various processes to which the milk is subjected. Milk is usually condensed in a vacuum pan, although a few concerns concentrate milk in an open pan in the following manner: The milk is run through a centrifugal separator and the cream removed. The skim milk is then pasteurized and run into rectangular vats provided with several pipes by means of which air is forced through the milk by a blower. During the process the skim milk is held at about 140° F., and the air, which is often heated by passing over steam coils, carries off the moisture in the milk, thus reducing its volume to the required consistency, usually about 4 to 1. After being thus treated it is known as concentrated skim milk. If concentrated whole milk is desired the cream which has been pasteurized is restored and emulsified in an agitator.

The equipment of a condensing plant using a vacuum pan depends upon the kind of product made, although the process used and the machinery required are similar for all condensed-milk products.

For the manufacture of "plain condensed milk" the equipment consists of a boiler, engine, scales and weigh can, receiving vats, milk heater, hot wells, vacuum pan and condenser, vacuum pump, cooling tank, and cans. If skimmed milk is condensed, a separator is necessary, as well as vats, pasteurizers, and coolers for handling the cream.

In the manufacture of sugared condensed milk the same equipment is necessary as for plain condensed milk, and in addition a tank is sometimes provided for dissolving sugar before adding it to the milk in the vacuum pan. If the product is put up in cans, machines for filling and sealing cans are necessary, also for making cans when they are not purchased from outside can manufacturers.

For making evaporated milk an equipment similar to that used in the manufacture of plain condensed milk is required, except that a tubular cooler is used for cooling the product instead of the cooling tank, and machinery for filling and sealing cans is also required; also a device for sterilizing the product in the cans, and a shaker for violently shaking the filled cans after sterilization.



A late innovation in equipping a milk condensery is the homogenizer. Difficulty is sometimes experienced by those engaged in producing evaporated milk in preventing a separation of the solids after it has been kept for a time, the lighter solids going to the top and the heavier ones to the bottom. As homogenizing normal milk prevents (partially at least) cream from rising, it is claimed that it will have a like effect on milk to be evaporated.

The granulation of the milk sugar, which gives evaporated milk the appearance of containing some kind of an objectionable grit, is also said by some to be overcome by the use of a homogenizer. This machine, however, has not been in use sufficiently long definitely to determine its value for the purposes mentioned.

The equipment of condenseries is quite uniform, but considerable variation is noted in operating, especially in the temperatures used. It is evident that no hard and fast rules can be laid down to follow under varying conditions. The following description of the process used in making the different grades of condensed milk and the cost of equipping was contributed by a gentleman who has had extensive practical experience in its manufacture and in manufacturing and installing such machinery, and probably is as nearly correct as can be obtained:

“ Plain condensed milk ” is made from whole milk, from part whole and part skimmed milk, and from skimmed milk. To get the desired density it is necessary to condense the whole milk 3 to 1 and the skimmed milk about 4 to 1.

The milk to be condensed is put into hot wells and heated with steam to a temperature of 150° to 156°. It is then drawn into the vacuum pan and condensed, if whole milk, to 10° Baumé, and if skimmed milk to 14° Baumé. As soon as the desired density is reached the milk is then superheated by blowing steam into the milk in the vacuum pan until the milk becomes thick. The temperatures used in this process vary from 175° to 200°.

As soon as the milk is sufficiently thick the steam is shut off and water is run into the condenser to secure the proper consistency. The vacuum pump is then started slowly, and the vacuum drawn up to about 26 inches. The vacuum is then released, and the milk is drawn into 10-gallon cans and placed in the cooling tank and cooled to 36° or 38° F. by first cooling as cold as possible with water and then shutting off the flow of water to the cooling tank and turning the brine or ammonia through the coils in the side of the cooling tank.

Sugared milk to be put up in cans is made from whole milk and is condensed 4 to 1 and 1 pound of sugar added to each 3 quarts of milk condensed. The milk is heated in the hot wells as hot as possible by steam blown into the milk through a heater head. It is then drawn into the vacuum pan and condensed. There are different methods used in adding the sugar to the milk. Some manufacturers have a separate tank, where the sugar is dissolved either in hot milk or hot distilled water, and the sirup so made drawn into the vacuum pan gradually with the fresh milk; others draw nearly all the milk into the vacuum pan and dissolve the sugar in the hot wells in the milk left there for that purpose. It is then drawn into the vacuum pan after the milk is condensed.

Sugared condensed milk to be sold in bulk is made from part or all skimmed milk in the same way as the canned goods, except that 1 pound of sugar is added for each 4 quarts of skimmed milk to be condensed. This class of goods

is used by bakers and confectioners, and is made with any desired per cent of butter fat from whole milk to full skimmed milk.

Evaporated milk is made from whole milk and is heated in the hot wells the same as for sugared condensed milk. This milk is condensed in the vacuum pan until it has the required percentage of solids and butter fat desired by the manufacturer. After the milk is condensed it is run over a pipe cooler and cooled to about 60° and is then put into small cans and sealed. As soon as it is sealed it is put into the sterilizer and heated to about 240°. While in the sterilizer the milk is kept in motion, so that the contents of the cans will be heated through evenly. The time required depends upon the size of the cans and the condition of the milk and varies from 18 to 45 minutes. As soon as the milk is sterilized it is immediately cooled in the sterilizer, and when cold it is removed from the sterilizer and shaken in a shaker until it is smooth.

A small condensed-milk plant for making plain and bulk-sugared condensed milk with a capacity to condense 10,000 pounds of milk a day can be built complete for about \$7,500; a 20,000-pound capacity plant will cost about \$13,000, and a 40,000-pound capacity plant will cost about \$20,000. The above estimate is based upon complete equipment and plain but substantial building.

The cost of the plant to make canned goods depends largely on how completely it is equipped and whether the cans are manufactured in the plant or purchased from some can-manufacturing company. The cost of canned-goods plants ranges from \$20,000 to \$200,000, depending on the size and style of the equipment and building. It is not practical to make canned goods where the milk supply is less than 15,000 pounds per day.

#### DESICCATED MILK.

##### DEVELOPMENT OF THE DESICCATED-MILK INDUSTRY.

Practical processes of converting cows' milk into dry milk powder are of comparatively recent discovery. According to the best authority, descriptions of such processes were first published in 1901, although it is claimed that skim-milk powder had been successfully made prior to that time.

A consular report from Sweden dated November 20, 1901, refers to a process reported to the Academy of Agriculture held in Stockholm, Sweden, that month, and the New York Produce Review and American Creamery, dated January 1, 1902, refers to a similar process used in America and claims its discovery prior to the Swedish process. Since that time the processes have been considerably improved and several different systems have been evolved. Several factories have also been established, both in this country and in Europe, for the manufacture of this product on a commercial scale.

#### MARKETS.

The market at the present time is mainly with bakers and confectioners, but when the nutritious properties and keeping qualities of dry milk are better known it may become a household article of common use.

## SCOPE OF THE INDUSTRY.

In May, 1911, there were 10 factories engaged in desiccating milk in the United States, located in five States, namely, Vermont, New Jersey, New York, Michigan, and California. The amount of milk powder produced in the calendar year 1910 by the various plants in the country was approximately 8,500,000 pounds. The capacity of the plants then in operation was 891,000 pounds of liquid milk per day of 10 hours, or 325,215,000 pounds per year. Assuming the yield of dry milk to be at the rate of 9 pounds to 100 pounds liquid milk, the yearly capacity of dry milk for the plants then in operation was 29,269,350 pounds.

## MACHINERY.

The machinery for drying milk is specially constructed for the purpose under various patents, and is, therefore, expensive. Factories are often equipped with apparatus made by mechanics in the vicinity of the plant, although there are manufacturers who make such machinery on order. The various systems are generally protected by patents, and already more than 60 patents have been issued covering devices for making this product.

## PROCESSES.

Drying milk from which the fat has been removed seems to be a success. It converts a wholesome and nutritious article of food into a condensed form, convenient to handle and transport, and ready at all times and under any circumstances for immediate use whenever and wherever wanted. Milk is changed by the drying process from a quickly perishable, bulky, and inconvenient substance to transport into a product requiring comparatively little space, and its keeping qualities are practically unlimited.

Probably over 90 per cent of the milk powder produced at the present time is made of skim milk. From 100 pounds of whole milk of average quality 3.5 pounds of butter fat and 9 pounds of dry skim milk can be secured. Dry skim milk powder has the appearance of ordinary flour made from grain. It absorbs moisture readily, which must be avoided by using containers that are as nearly as possible air tight and moisture proof and by storing in cool, dry places. This grade of dry milk possesses in a condensed form all the valuable properties of fresh sweet skim milk. It can be used in the dry form by bakers and confectioners, or, if desired, it can be converted back to its original liquid state by adding the amount of water that has been extracted from it. In drying whole milk more difficulties are encountered. The keeping qualities of dry whole milk

are not equal to those of skim milk. The fatty part has a tendency to become rancid, and, where rancidity does not develop, when some months old it loses its freshness and lacks the fine flavor of fresh milk; at least such has been the case with samples tested under the writer's observation. Its keeping qualities are superior to those of liquid milk, however, and it is a very desirable substitute when fresh milk can not be obtained.

Besides milk powder from whole milk and from skim milk, there are upon the markets intermediate grades, frequently sold under coined names. It may be well to state that dry whole milk of average quality contains about 27 per cent fat, varying somewhat according to the richness of the milk. In some instances whole milk reinforced with cream has been dried which contains from 30 to 40 per cent butter fat.

Two distinct methods of drying milk are in use, from which several systems have been evolved. In one method the milk, in the form of a spray, is forced into a chamber of hot air, with an air current driving the dry particles against a screen, which arrests the solid portions and allows the air to pass on. A more general device is the heated cylinder, to which milk is caused to adhere in a film, quickly drying, and, as the cylinders revolve, the dried matter is scraped off in sheets or ribbons. These are collected and, if necessary, further dried and then reduced to a fine powder. In most instances the milk is partially condensed in a vacuum pan before entering the drying machine.

The following extracts from authorized descriptions of some of the various systems in use will give a general idea of the modification of the two methods above described:

#### EKENBERG SYSTEM.

As the milk is received at the factory it is filtered through cotton as it passes to the receiving vat. From this vat the milk passes directly through a heater, where the temperature is raised to 90° F., and without stopping in its flow it passes to a battery of separators, which remove the butter fat and at the same time further clarify the milk. The cream from the separators passes to a pasteurizer, which not only heats but promptly cools again. The cream is at once run into cans and placed in cork-insulated pools, which are cooled to a low temperature by brine coils supplied by an artificial ice plant. The cream is later taken from the pools and reunited with the separated milk for the higher grades of powdered milk. The separator milk flows directly to a pasteurizer and, after being reduced to a low temperature, flows at once to an insulated tank, from which it is drawn directly to the exsiccators. The exsiccator

is the name given to the machine invented by Dr. Martin Ekenberg for the purpose of removing the water content of milk and other liquids. It is not necessary to go into the minor details of the construction of this machine, and it would be difficult to do so, as some of its parts are exceedingly complicated. Briefly, however, it consists of a large vacuum chamber in which is hung a milk cylinder which nearly fills the vacuum chamber. This cylinder is supported at its axes by trunnions, one of which extends outside of the chamber, providing a means to revolve the cylinder. Connected with the vacuum chamber and in front of it is another chamber, also under vacuum. This chamber is known as the products chamber, and is separated from the vacuum chamber by a series of gates, the use of which permits the maintenance of a constant vacuum in the vacuum chamber and the opening from time to time of the products chamber.

There is also attached to the vacuum chamber a milk chamber which is constantly under vacuum, and into which the milk is drawn from the outside. Another important part of the apparatus is a specially constructed condenser to which is attached the suction pipe of a large vacuum pump, and this is also provided with a large stream of water, which, passing constantly through the condenser, cools the vapors, reducing them to water, which is carried away.

To the milk chamber is attached a pump which forces the milk through a spray pipe on to the revolving cylinder. The cylinder is heated slightly by exhaust steam, and on account of the high vacuum the thin layer which is deposited by the spray pipe upon the cylinder is quickly dried upon the surface of the cylinder, and a series of silver knives removes this film of dried milk. It passes directly into the products chamber, and by manipulating the gates it may be removed from the products chamber without the loss of the vacuum in the remainder of the apparatus.

The temperature of the milk at no time has thus far gone above 120° F., and in fact it rarely exceeds 110° F.

When the dried film of milk reaches the outside air it is slightly moist and flexible, and in order to crystallize the lactose or milk sugar which comprises from one-third to one-half the total weight of the dried milk it is necessary to place the product in a heated chamber at 90° F. from 20 minutes to an hour.

When removed from the drying chamber the product is in the form of dry, crisp chips and ribbons as thin as paper and as brittle as a wax wafer. It is then reduced to a very fine powder by specially constructed mills, which grind without heating or in any way injuring the delicate elements of which the milk is composed. As the milk powder comes from the mill it is packed ready for the consumer.

## ATOMIZING AND HOT AIR SYSTEM.

Robert Stauf, of Posen, Germany, devised a process for producing dry powders from blood, milk, etc., by atomizing these liquids into supplementary regulated currents of heated air. The amount of air and heat supplied was sufficient to completely absorb and vaporize the moisture of the liquid and the resulting dry powder was separated from the moisture-laden air by means of a screen. The screen retained the powder and the air passed off through the screen. The Stauf process was the first spray drying process to be commercially used in the United States.

## THE JUST SYSTEM.

The drying machine is comparatively simple, being composed of two polished metal cylinders placed side by side and slightly separated from each other. They are mounted in a heavy, solid iron framework, and revolve inversely at the rate of about six revolutions per minute. They are heated in the interior by superheated steam, at a pressure of about 45 pounds to the square inch, which makes the outer temperature of the rollers considerably above 212° F. The milk is introduced into the machine by a pipe which runs between the rollers, about 6 inches above their convergence, and as soon as the milk strikes the rollers evaporation commences. The milk passes gradually between the cylinders and is carried in a thin, uniform layer upon each, the layer being thinner than the thinnest tissue paper. Whatever water is not evaporated at the point of convergence is dried out of the layer in its passage on the revolving hot cylinder, until the film reaches a knife held in contact with the cylinder, which removes the milk in long, continuous sheets, which fall into a receptacle below, where they are broken into innumerable small pieces by the fall and rapidly cool. To collect and carry off the steam arising from evaporation the machine is provided with a large hood leading into a pipe. On an upper floor an exhaust fan is located connected with all these different pipes, thus carrying the steam rapidly out of the hoods and keeping the building absolutely free of it. As soon as the boxes into which the sheets or rather broken pieces of dry milk fall from the rollers are filled, they are wheeled to a brushing machine, where the product is reduced to a uniform powder, and after having been spread on large hardwood tables to cool thoroughly, is ready for packing and storing or shipping.

## THE CAMPBELL SYSTEM.

The milk is pumped into a large round copper vessel, where it is agitated and heated by sterilized air blasts preparatory to its being pumped into rectangular concentrating vessels. These concentrat-

ing tanks are provided with a circulating medium of hot water surrounding them and coils in their interior. They are also provided with pipes and fan-shaped nozzles for the introduction of sterilized air below the surface of the milk. This air is under pressure and is allowed to escape when the tanks are charged with milk, and causes the water vapor to be driven off. The milk here has a violent rolling motion. As the product becomes concentrated the temperature is lowered. The opening of a valve permits the mass to fall into the large roller drums with tapered ends, which are located on a lower floor. These roller drums are tin plated and are perfectly smooth on the inside, with cone-shaped ends. An air blast is then introduced into the head of the drum. The latter revolving about two turns per minute carries the pasty product up on its side, and as it approaches the top it falls back through the dried atmosphere, the air thus carrying away the moisture. This paste soon becomes too heavy to be carried up by the revolving of the drum and rolls into a large mass, the cone-shaped ends causing it to move unequally, and twisting and grinding it into small particles. These are then conveyed to the drier drums, where the desiccation is completed. These drier drums have a novel construction. Sterilized air is forced through a central shaft having lateral arms extending down into the mass, where the constant rolling of the drum exposes all parts to the desiccated air. When the product is bone dry, it is conveyed to a grinder, which brings it to about the consistency of corn meal, and it is then packed.

#### THE PASSBURG SYSTEM.

The Passburg dryer is a large steam-heated iron drum revolving in a vacuum chamber. The milk is fed to it cold, and is scraped off by a steel knife, in thin sheets, and is perfectly dry when taken from the receiver.

# HOW THE PRODUCE DEALER MAY IMPROVE THE QUALITY OF POULTRY AND EGGS.

By H. C. PIERCE,  
*Food Research Laboratory, Bureau of Chemistry.*

## INTRODUCTION.

In marketing poultry and eggs there is an enormous preventable loss in quality and value between the producer and the consumer. It has been conservatively estimated that this loss amounts annually to \$75,000,000 in poultry and \$45,000,000 in eggs. While this loss falls upon all who handle poultry and eggs it is borne chiefly by the producers and the consumers. The producers' loss, caused by a decrease in price, under present conditions represents that due to spoilage or poor quality. The consumers' loss is due to a curtailed supply because of the pounds of poultry and dozens of eggs that are either of poor quality or a total loss; hence the consumer has to pay a higher price for that portion which finally reaches him.

While these losses are increased at all stages of handling by the producer, the country storekeeper, the produce dealer, the railroad, the commission man and jobber, and the retailer, the greatest preventable loss occurs before the produce dealer obtains the goods, that is, while the poultry and eggs are still on the farm or in the hands of the small country storekeeper, whose responsibility is moral rather than financial. The produce dealer, in paying a flat rate for poor and good poultry and bad and good eggs, offers no incentive for any improvement in quality by the producer nor conservation of quality by the storekeepers who take poultry and eggs in trade for groceries or supplies. As the produce dealer controls the price paid for poultry and eggs in the country districts, he is the one best fitted to aid in the improvement of quality and increase in quantity of these products.

It is the purpose of this article to point out a few of the many ways in which the produce dealer may work for better quality in poultry and eggs in his district.

## BUYING ON A QUALITY BASIS.

The quickest way to arouse a desire in the producer to raise better chickens and supply better eggs is to show him that good quality poultry and eggs are worth more than those of poor quality; the



produce dealer must pay more for large, clean, fresh eggs than he does for those which are small, dirty, and stale. Otherwise there is no financial incentive for the farmer to improve his output, or the storekeeper or other intermediate handler to market his eggs frequently. It costs the farmer more to produce large, clean, fresh eggs than it does to produce small, dirty, and rotten eggs, for the hens' nests must be kept clean, and the eggs must be gathered frequently and marketed often. Unless he receives an increase in price for his good eggs it is not good business for him to perform the extra labor necessary to conserve the quality of his goods.

#### DIFFERENCES IN PRICE.

The difference in prices paid for the different grades of eggs varies with the season and the market prices for the different grades in the consuming markets. In the spring, when egg production is at its flood, and eggs are cheapest, the difference in price may be as low as 2 cents a dozen. In the fall, when the hens are not laying freely and the prices for strictly fresh eggs are soaring, the price may differ as much as 14 cents a dozen between the highest and lowest grades of marketable eggs. As an example of the variations that may be paid, one southern poultry shipper in November, 1912, paid 35 cents a dozen for large, clean, absolutely fresh eggs; 28 cents for a second grade which were slightly smaller, but clean and a little less fresh; and 21 cents for a third grade, consisting of small, dirty, and stale eggs; rotten eggs were not purchased at any price. The average market price for eggs in his vicinity at the time was 27 cents. Thus the producer of the highest grade eggs received an increase of 28 per cent over the market price and 66½ per cent over the price paid for the lowest grade. Such variations gave the produce dealer a profit on all grades and made it worth while for the farmer to produce better eggs. Where eggs are bought at an average price the dealer must sell his lower grades for less than he paid for them and make up this loss and procure his profits from the sale of the higher grades.

#### KNOWLEDGE THE DEALER SHOULD HAVE.

Some produce dealers say that it is impossible for them to buy eggs on a graded quality basis because their competitors pay a flat rate. That this is not true is proved by the several firms throughout the country that are buying on a quality basis and making a profit thereby. The produce dealer must know, however, how to candle and grade eggs so that he may buy intelligently, and must



CANDLING EGGS AT THE FARMER'S GATE.

make an effort to show the people from whom he buys how these different grades are determined. Whenever this quality method of buying has been pursued the quality and quantity of eggs produced has rapidly improved and increased.

In poultry also different kinds and weights bring different prices. As a rule mature fowls weighing over 4 pounds are worth more a pound dressed than birds under this weight. Therefore, some dealers pay from 2 to 4 cents more a pound for large than for small fowls. This varies with the market, as in the case of eggs, but enables the producer to receive a fair difference in price and the dealer to make a profit on both grades.

It is only fair to the producer that if a produce dealer sells eggs and poultry on a graded basis he should buy on that basis also. Furthermore, it means that the dealer can make a profit on all of the stock he buys instead of on only the best.

#### POULTRY EDUCATION.

While buying poultry and eggs on a graded quality basis increases the desire on the part of the producer to supply more and better poultry and eggs, it does not, in itself, teach him how to do so. Thus, having shown the producer that better poultry and eggs mean more money, the produce buyer will find it profitable to do what he can to help the farmer to secure aid and knowledge in the production of better stock. Fortunately there are now many ways in which this aid and instruction may be given.

#### EGG-CANDLING DEMONSTRATIONS.

From time to time the produce dealer may hold candling demonstrations for the benefit of his buyers, the storekeepers, and farmers. He should be able to show the difference between fresh eggs, stale eggs, heated eggs, blood rings, mixed rots, black rots, and mold spots before the candle, and then break the eggs to show the quality of their contents. The causes of deterioration are then explained. These demonstrations may be held on stated days, when farmers come to town, or in connection with county fairs, farmers' institutes, poultry shows, and country schools. If a buyer goes from farm to farm, he may explain the different grades by candling the eggs before leaving the farm. Plate XXXIII shows such a buyer candling eggs at the farmer's gate and showing the difference between a fresh egg and an egg that has developed a blood ring because it was fertile and kept in a warm place for several days. His "candle" is made from a pasteboard egg case flat, rolled into a tube, through which he

looks at the egg to determine the quality by the sunlight transmitted through it.

#### HELPFUL HINTS TO FARMERS.

Several produce dealers have distributed among their customers printed pamphlets containing brief items on the selection of breeding stock, incubation, raising of chickens, feeding of laying hens, construction of poultry houses, gathering and care of eggs, prevention of diseases, extermination of vermin, etc. One man, interested in turkeys especially, reprinted a Government bulletin on the raising of turkeys and distributed it to all of the turkey raisers in his section. These pamphlets usually bear the name of the firm and serve as an advertisement as well as aid in the production of better poultry. The material for these sheets or booklets is obtained from poultry publications of the United States Department of Agriculture, bulletins of the various State agricultural colleges, poultry journals, and the experiences of successful poultry raisers.

#### COUNTY FAIRS AND POULTRY SHOWS.

One of the best opportunities whereby the produce dealer may improve the quality of poultry and eggs in his vicinity is the offering of prizes and arranging of demonstrations at the county fairs and poultry shows. As most fair directors are anxious to have as much money as possible for prizes, the produce dealer may encourage the production of those breeds of poultry which he deems best by offering special prizes for specimens bred in his locality and for the best dozen white or brown eggs. One firm in Iowa, desirous of large fowls for sale in eastern markets, offered at local shows prizes of \$5 each for the best pullet pens, consisting of one cockerel and four pullets of the most popular variety of Plymouth Rocks, Wyandottes, Rhode Island Reds, and Orpingtons. In five years the production of pure-bred birds of these breeds increased enormously, and the farmers were able to pack a much better grade of poultry than their competitors, for which they secured higher prices. Other firms also, by offering prizes on eggs, have increased the quantity of pure-bred poultry kept and the number of eggs produced.

Fairs and shows offer opportunities for the produce dealer to arrange displays of the different grades of eggs showing the variations in value, good and poor breeding stock, desirable types of poultry, foodstuffs for poultry, models of poultry houses and appliances, charts, demonstrations in the grading of eggs, and many other similar exhibits.

## DISTRIBUTION OF BREEDING STOCK AND EGGS FOR HATCHING.

As the domestic fowl reaches maturity in one year and has great powers of reproduction, the quality of the flock may be rapidly improved by the introduction of pure-bred stock. This has been most generally done in the past by the distribution of pure-bred males by the dealer to the farmer, who mates them with his best hens. It should be stipulated that all scrub males are to be eliminated from the flock, the pure bred only being used for breeding.

Although the flock will be lifted above the scrub variety by this method, it will not consist of anything above grades. An entire substitution of pure blood for scrubs can be accomplished only by hatching eggs from pure-bred stock. Pure-bred breeding pens, consisting of females and one male, cost more than the average dealer can afford for general distribution. It will, however, pay him to furnish a few farmers with such flocks, on the condition that the stock shall be kept pure and the eggs laid during the breeding season be available for wide distribution at approximately market prices. If the dealer furnishes the farmer with one or more settings from a pure-bred flock, with the understanding that the chickens are to be raised in increasing numbers from this pure-bred stock, at the end of three years the flock should consist entirely of pure-bred fowls.

Since fowls which have been given by dealers to farmers have not been appreciated and have brought disappointing results, it has been found best to sell them for a cash price, or exchange them for an equal amount of common poultry. The eggs should be furnished in the same way, a satisfactory basis of exchange used in the country breeding stations in Ireland being to furnish a dozen hatching eggs for a dozen ordinary fresh eggs plus a shilling, approximately 25 cents in American money.

Such an improvement in the quality of his flock enables the farmer to obtain higher prices for his poultry, because of its larger size or increased egg production. The dealer profits by the greater amount and better quality of poultry and eggs handled by him.

## COUNTRY SCHOOLS.

The produce dealer should be one of the first to take an interest in the rapidly rising tide of agricultural education now flooding the country and see that poultry receives its share of attention. There is no better way of improving the methods of handling poultry and eggs on the farm than by interesting the children in the country schools, since they are often the caretakers of the poultry. Fowls are an especially good subject for use in agricultural teaching, because they are more generally raised on the farms of this country than any other kind of live stock. They are also cheap, easily kept,

and, with their eggs, furnish good material for studies such as embryology, physiology, anatomy, reading, writing, and arithmetic, as well as the care of poultry itself. Every country school should have a flock of chickens cared for by the children.

The produce dealer may encourage activity in poultry lines by furnishing the schools with eggs for hatching, small flocks of hens, poultry houses, incubators, etc.

#### FARMERS' INSTITUTES.

In many of the States the legislatures, through the boards of agriculture or agricultural colleges, have provided funds for the holding of farmers' institutes. Poultry talks should be upon every program of such gatherings. Most States have experts who may be secured to give these addresses, provided their expenses are paid by the meetings which they attend, their salaries being paid by the State. The value of these talks to the produce dealer is usually worth more than the cost of securing the services of such an expert. Therefore it is a good investment for the dealer to guarantee these expenses personally, if the institute has insufficient funds for this purpose.

#### PUBLICATIONS OF THE UNITED STATES DEPARTMENT OF AGRICULTURE AND STATE EXPERIMENT STATIONS.

While many buyers of poultry and eggs know that the U. S. Department of Agriculture and the State experiment stations have conducted investigations relative to the raising and handling of poultry and eggs, very few of them know how to secure these publications. For publications of the U. S. Department of Agriculture requests should be sent to the Superintendent of Documents, Washington, D. C. If requests for available poultry publications are sent to the directors of agricultural experiment stations at the addresses given on page 352 much valuable information can be obtained.

Most of the publications referred to are available for free distribution; on some a price is charged to nonresidents of the State wherein they are issued. Much valuable information from these sources may be copied and distributed by the dealer to the farmers, or a list may be distributed telling the poultry raiser how to secure these bulletins.

Every dealer should get in touch with his own State experiment station and follow closely its poultry work. The poultry workers in experiment stations are anxious to aid in the development of the

industry in their States and appreciate heartily the cooperation of dealers and farmers, whose interest increases the appropriations that may be secured for the advancement of the work. In the few States where the experiment stations do no work on poultry problems the produce dealer should do what he can to aid in the establishment of such work by cooperating with his competitors, arousing interest among legislators, farmers' organizations, and State officials.

#### POULTRY SHIPPERS' ASSOCIATIONS.

Although all of the suggestions offered in this article have been practiced at different times by many shippers with excellent results, what has been accomplished has been because of individual efforts on the part of the shippers. Much more could have been accomplished if they had been put into effect by all of the shippers in unison, as through an organized effort of poultry shippers' associations. For his own good every shipper should belong to one or more of the several shippers' associations throughout the country, which are frequently addressed by the foremost handlers of poultry and eggs, as well as by Government and State experts, and are centers from which radiate many progressive ideas. They create confidence among shippers, give each man a broader view of his own business, and tend to increase his profits by aiding in the prevention of his losses. Through these organizations experts may be employed to aid the farmer in solving his poultry-raising problems and give greater publicity to the value of the poultry industry. This tends to create a realization on the part of the farmer that poultry is more than a mere side line on the farm and to increase his output, thereby aiding the consumer to secure a larger quantity and better quality of nutritious food.

*Post-office addresses of the agricultural experiment stations.*

Auburn and Tuskegee Institute, Ala.	Bozeman, Mont.
Sitka, Alaska.	Lincoln, Nebr.
Tucson, Ariz.	Reno, Nev.
Fayetteville, Ark.	Durham, N. H.
Berkeley, Cal.	New Brunswick, N. J.
Fort Collins, Colo.	Agricultural College, N. Mex.
New Haven and Storrs, Conn.	Geneva and Ithaca, N. Y.
Newark, Del.	Raleigh, N. C.
Gainesville, Fla.	Agricultural College, N. Dak.
Experiment, Ga.	Wooster, Ohio.
Island of Guam, Guam.	Stillwater, Okla.
Federal Station, Honolulu, Hawaii.	Corvallis, Oreg.
Moscow, Idaho.	State College, Pa.
Urbana, Ill.	Mayaguez, P. R.
La Fayette, Ind.	Kingston, R. I.
Ames, Iowa.	Clemson College, S. C.
Manhattan, Kans.	Brookings, S. Dak.
Lexington, Ky.	Knoxville, Tenn.
Baton Rouge, La.	College Station, Tex.
Orono, Me.	Logan, Utah.
College Park, Md.	Burlington, Vt.
Amherst, Mass.	Blacksburg, Va.
East Lansing, Mich.	Pullman, Wash.
University Farm, St. Paul, Minn.	Morgantown, W. Va.
Agricultural College, Miss.	Madison, Wis.
Columbia and Mountain Grove, Mo.	Laramie, Wyo.



# A SUCCESSFUL METHOD OF MARKETING VEGETABLE PRODUCTS.

By L. C. CORBETT,

*Horticulturist, Bureau of Plant Industry.*

## INTRODUCTION.

In order to discuss satisfactorily any improvement on or modification of the present method of marketing perishable crops, such as vegetables, it is necessary to review briefly existing practices. The present method of marketing vegetables may be spoken of as that of independent action. In a country like the United States any criticism or suggested modification of a system of independent action would seem to be a criticism of the fundamental principles of our Government, but a criticism of the method of independent action in connection with the marketing of a perishable product is by no means a criticism of our system of Government. The system of independent action, so far as it applies to the marketing of vegetable crops, is open to the following criticism: Independent action means wide variation in types of packages, as is exemplified in our markets at the present time. Packages of all sizes and descriptions are received in the markets from various districts, so that a quotation on a basket, hamper, or container in one market may mean little in another section. The packing of the product is done according to the ideas of the individual directing the work; the grades are founded upon his personal notion of what constitutes a first, second, or third grade, judged by the product he himself handles and not by any market-standard.

Shipments are, for the most part, by local freight or express. Sometimes a grower is able to load a few cars from his own field, but this is the exception rather than the rule. The result is that any brand which he may adopt appears in the market at uncertain intervals, remains but a short time, and disappears until the succeeding year. It is very difficult under such conditions to build up a reputation for one's product and to establish a standing for a brand or style of package which will serve to assist in the sale of the crop the following year. Such shipments must, of necessity, be consigned to commission merchants, and in some instances are sold at auction

and in others at wholesale in the regular channels of trade. A new, untried, or unknown brand, no matter how good it may be, is at a decided disadvantage in auction sales and at a slightly less disadvantage in the regular wholesale trade. As a rule, large lots of recognized grade and brand can be sold at the early auction and return greater profits than small lots which have to wait for the later trade.

A product, after it has reached the city and before it is ultimately delivered to the consumer, may go through any or all of the following agencies designed to promote trade: After reaching the commission merchant or receiver, it may be purchased by a jobber or handler, or go to a broker, by whom it is sold to a retailer, from whom it goes to the consumer. The receiver, jobber, broker, or retailer may, however, place the product in a warehouse or in cold storage. The factors, therefore, which may enter into the ultimate cost of the product to the consumer are:

(1) Cost of transportation, including (a) freight or express; (b) terminal or switching charges, and (c) drayage; (2) commission; (3) jobber's or dealer's profit (change of ownership); (4) storage charges; (5) distributor's profit (change of ownership); (6) the cost of growing, packing, and hauling to the shipping point is never taken into account in determining the cost of the product to the consumer, except in so far as the return made by the commission merchant, jobber, or dealer affects this price. The farmer has an investment in land, labor, and product which is never considered in modern trade because he is never a party to any transaction, unless, perchance, he is able to sell his product f. o. b. shipping point, and even then he does not fix the price, but simply accepts or rejects the price offered. The question of the cost of production plus a fair profit is not taken into account in agricultural transactions as in other productive enterprises. In fact, farmers themselves, with few exceptions, have no idea of the cost of producing many of the crops they offer for sale. The cost of production in any single year should not, however, be taken as the basis for the cost of a given product. Seasonal variations are so great that the only just basis for determining the cost of any product is its average cost on a given farm over a series of 5 to 10 years.

A careful analysis of trade conditions indicates that from 33 to 36 per cent of the price which the consumer pays for a perishable product reaches the producer. This must cover the cost as well as the risk of growing, and must also provide the profit on the "know how" and money invested. About 26 per cent of the cost to the consumer is required for transportation and from 5 to 10 per cent for commission. Dealers' profits range from 50 to 100 per cent, for it is maintained that every time perishable goods change hands the

selling price must double the purchase price in order to meet losses. As the retailer receives the goods he again adds 100 per cent or thereabouts to the cost to the consumer. It is easy to see how high costs necessarily follow such methods of marketing. If, in addition to these costs, terminal-storage and cold-storage charges are added, as is often necessary in order to maintain even distribution, and the retailer sells the goods by telephone and delivers them by horse or motor vehicle, all of these so-called conveniences must ultimately be paid for by the consumer. Under the present system it is possible for some of the common perishable products to carry eight distinct charges before they reach the consumer, all of which are legitimate; and as these charges on perishable products must be high in order to fortify the owners against loss, the reason for high prices for standard vegetable crops is easily explained. So long as society is constituted as it is and demands the services it now requires of the tradesman, little relief can be expected after the products are delivered to the dealer.

#### THE COOPERATIVE SYSTEM.

##### REGULATION OF PRODUCTS.

A system of marketing, based on cooperative action rather than on independent action, has been developed in some localities and at the present time is attracting much attention in others. Up to the present cooperative activities have been confined almost exclusively to the fields of production, transportation, and first sales. It is difficult for the producer to go beyond the first change of ownership unless he has a cooperating consuming public. Now that the consumer really feels the stress of high prices and has come to realize and appreciate some of the factors which enter into them, it is clear that the task of solving the problem of cheaper food products lies with him as much as with the producer.

Cooperation among growers solves the problems of the package by making it uniform and standard, it guarantees the pack by employing competent inspectors, and insures uniformity of grade. Cooperative action enables the cooperators to act as an independent individual, and since they employ a uniform package, a standard pack, and uniform grades a given product of a community can be shipped in carload lots at a lower rate than is possible by local freight or express, thus effecting a decided saving. A uniform package and a standard pack and grade give a product a standing in the market which enables it to be sold for what it really is, because the guaranty of the association is behind it.

Another advantage which often follows is a local or direct sale, f. o. b. shipping point. In the eastern portion of the country the

f. o. b. sales have been made on the basis of New York prices current. The distribution of products to many consuming centers rather than congestion in a few is one of the most valuable results secured by cooperative action. Cities which are large enough to handle a single commodity in carload lots when it is purchased from the producer receive their goods direct rather than by a diverted shipment or by reshipment. The product reaches the market quicker and in better condition, and as the dealer in the small town must of necessity pay for the reshipment of the product from the distributing center it is quite as economical in most instances to purchase the product f. o. b. shipping point and pay freight as it is to purchase f. o. b. distributing point and pay freight. The price to the consumer or to the handler in the small town is reduced by one freight charge and sometimes also by the cost of commission or jobber's profit. One association has been able to sell over 90 per cent of the truck handled by it f. o. b., and this has resulted in a saving of over \$150,000 annually on a \$2,000,000 business. In other words, the freight charges were paid by the purchaser instead of by the producer, thus saving to the community the cost of transporting their products to the centers of consumption or distribution.

Towns too small to handle "straight" cars of a single commodity, with the possible exception of potatoes, can be served in the same manner as large towns by a system of loading which has been devised by some of the railways receiving products from the trucking districts. This system consists in loading mixed cars to order, so as to supply the needs, as near as may be, of the town to which the shipment is made. This method of handling mixed cars accomplishes a very desirable result, in that it widens the distribution of the product by reaching towns too small to handle solid cars of a single commodity and enables the dealers to purchase direct from the producer, thus insuring all the advantages of direct shipment possible by any other system of carload shipments. By the adoption of a carefully planned cropping system in the several producing centers from which such shipment is to be made a very satisfactory arrangement for both the producer and the consumer can be worked out.

If the products of various centers are to follow in succession to the same markets and are to be handled on the basis of sales f. o. b. shipping point, the producers must not only maintain standard packs and grades which are uniform, but they must also be in touch with the markets in such a way as to insure prompt and satisfactory disposal of their products. At present this is accomplished by wide-awake, active dealers who know the markets and the producers as well, and by purchasing in one locality in January, in another in February, and so on from season to season, thus keep their customers supplied from the beginning to the end of the period. Neither inde-

pendent producers nor associations of growers with fixed fields of production can do this. They reach the market only during the period their crops are moving. What is accomplished by the independent dealer might, however, be accomplished by cooperation among various local associations of producers. Through a federation of such associations a marketing expert might be maintained who would move with the season from one center to another. By so doing the markets would deal continually with the same individual, the grades and packs would be calibrated, because censored by the same authority at each loading point. In this way the community might accomplish for itself what is now taken advantage of by shrewd and wide-awake dealers.

#### REGULATION OF PRICES.

Under the system of independent action producers are creatures of circumstances over which they have no control. At harvest time they have little conception of the competition they will have to meet in the market, unless the crop is so short that it has become a matter of comment. As a rule the dealers see to it that the reports on crop prospects are high enough to enable them to buy the harvest at a reasonably low figure. It is never discovered that the crop is a little short until after it has all left the hands of the grower and is safe in the storerooms of the dealers.

Dealers keep an accurate forecast of the crop and as a rule have a good basis for their action. Growers have not done this except in a few instances, and then with marked advantage. Cooperative growing associations should establish through some central organization a plan by which accurate forecasts of crop prospects can be furnished. These forecasts should begin with the acreage in each crop zone and end with a statement of the harvest. These reports should be made at frequent intervals and should be based on accurate personal canvass by competent judges. A few seasons' records for any given locality will suffice to furnish a basis for determining the safe acreage for that section and to fix the planting and harvest dates, as well as to indicate the normal product which may be expected from a given acreage. Statistics of this character would provide a basis for working out a rational system of crop rotation and crop production.

Cooperative action with products which can be stored enables the producer to distribute the product throughout the consuming period in such a way as to meet the requirements of the market without overloading it and depressing prices. With vegetable products, such as Irish potatoes, sweet potatoes, and squashes, this is a very important consideration; the trade quickly determines the center of supply, and as soon as the markets create a

demand the supply can be forthcoming in a regular, systematic manner, so as to cause the least loss to producer, handler, and consumer. Under this system storage products should never be compelled to beg a market; the demand will always find the supply. The chief advantages, therefore, of cooperative action are standard grades, standard packs, uniform packages, shipment in carload lots, f. o. b. sales, a controlled rate of dispersal, predetermined destination, dispatch in the settlement of claims, and regulation of rates of transportation and of sales, so as to give each producer a standard price for a standard product.

To accomplish this is a difficult task. Human nature is the most variable and the least controllable commercial commodity. Cooperation means united action, and true cooperation in the sense in which it is used in this connection means united action for the benefit of all concerned—the producer as well as the consumer. Experience has demonstrated that the results derived from true cooperation are sufficiently important from a commercial standpoint to justify the method even though no other result were obtained.

#### COOPERATIVE ORGANIZATION.

Cooperation which involves financial risk and financial responsibility has never proved successful when based on fraternal agreement alone. To succeed in any business enterprise which requires the concerted action of individuals of different training and different temperaments, there must be a common bond of union of sufficient importance to give them a common interest. This can be secured in the business world only through a money consideration. In order, therefore, that cooperative action involving the growing, handling, transportation, and sale of perishable products may be successful it must carry a financial obligation sufficient to command the interest of the cooperators. It is true that in an association of this character the participants place at stake the return of their labor in the form of the crop produced, but in order to insure the patronage and the loyalty which is necessary to the stability of any cooperative action a membership requirement must be made sufficiently large to prevent a member withdrawing from the association for slight cause. A method which has been successfully used in some of the associations is to require a cash membership fee sufficient to raise the required capital for conducting the business of the association.

The amount of capital stock will vary with the character of the association, whether it be a growing and distributing organization or a growing, distributing, and purchasing organization. In order to purchase supplies for its members the organization will require a much larger capital than will be necessary for a growers' and distributors' association only. The minimum capital for a growers'

and distributors' organization would be in the neighborhood of \$2,000, while the stock necessary to add the purchasing and handling feature must be from \$10,000 to \$50,000. The cash membership fee should in few instances be less than \$25. If the requirements of the association demand larger capital the membership fee must be increased proportionately. In addition to the cash membership requirement a bond should be given in the form of a promissory note executed by each member in favor of the association, this bond to be held in trust as long as the member remains in good standing, to serve as a guaranty for faithful adherence to the constitution and by-laws of the association. If the organization be a producing and distributing one only, this bond will never need to be used except for the purpose of personal guaranty. If, however, the organization purchases supplies for its members, these personal bonds may be used by the association as collateral to guarantee short-time loans which from time to time may be needed to cover the expenses of purchasing fertilizer, packages, or other consumable supplies.

The association should in no instance lend money to its patrons or members for permanent improvements. Its business should be confined to providing consumable supplies. By this method the community represented by the association becomes security for the loan which is needed, and by this method so-called dynamic money or short-time loans can be secured for the benefit of persons who at the present time can secure money only with the greatest difficulty and at the highest rate.

Besides the benefits to be derived from cooperative growing, marketing, and purchasing, there might also be included banking and cooperative insurance, which is already an important factor in many rural communities. The bond which has already been mentioned in connection with the obligation of members can be used as the basis of the reserve or guaranty fund for the insurance feature. In a community where the cooperative insurance plan is already in operation the other features needed by the society might be gathered about it, as the parent society. Where cooperative growing and marketing organizations exist, they can be extended to include the purchase, loan, and insurance features. In most instances it will probably be wisest to inaugurate one feature of this comprehensive plan and develop it to a high state of perfection before adding the others.

The benefits of cooperative action in growing, transporting, and selling farm products can not be fully realized unless the members of the association each and severally consider themselves delegated to protect the interests of the association from criticism or dissension from within which would tend to limit the usefulness of the association, and they should also safeguard their community interests by discouraging the formation of competing associations. Cooperative

competition is equally as destructive as individual competition. Unfortunately, in some instances growers have not realized that the formation of competing organizations, although each of them is cooperative in its nature, is destructive to the best interests of the community as a whole. In fact, the organization and development of factional or competing associations in a community have been one of the favorite devices of those antagonistic to the success of the cooperative movement.

#### BUSINESS METHODS.

The basis on which the association secures its revenues is an important consideration, as is also the method of settlement with its members. Revenues are essential to meet salaries and legitimate operating expenses. The income of the association may be derived from a commission on sales or from a flat rate per package for goods handled. Either of these systems will prove satisfactory. The one which seems to meet best the requirements of a particular association should be adopted. Purchases should be treated the same as sales. The price to members should include first cost, transportation, handling, and a sufficient profit to yield the necessary revenue to cover the expense to the association. Even when this is done experience proves that a very substantial saving can be made. In some instances the moneys received from the sale of products, less a commission or deduction for the charge of selling, are returned direct to the individual furnishing the products. In other instances, where the products are given a uniform brand and are sold on grade so that the individual's product is lost sight of, the returns for a given period are pooled and are prorated among those contributing to the sales during that particular period. In most instances it will be found best to sell products under brand and grade, and to pool the shipments for a given period—the period necessarily being short, not to exceed two or three days—and to prorate the sales among the shippers on the basis of the number of packages and their grade during that period.

A short pooling interval is desirable in order that growers who succeed in producing early crops, which often command a higher price, may be given the benefit of this advantage. A long pooling period would give the tardy harvest the advantage of a portion of the reward which should go to the early crop. This difficulty in the distribution of the returns, even where crops and returns are pooled, can be overcome by a short pooling period.

The business of the association should be handled by a manager under the direction of a board of directors who really direct. Important transactions should be governed by the concerted judgment of the board of directors and the manager, rather than be left to the judgment of the manager alone. An association which does not



maintain a board of directors of, say, three persons who really manage the business should never find fault if that business is not well transacted. The officer of the association upon whom responsibility devolves should be paid a liberal compensation for the services rendered. The business ability, foresight, and energy of the business manager, under the control of a board of directors, determine the success or failure of any cooperative enterprise as surely as the business ability of the head of any firm determines the success or failure of that firm. The business manager employed should, therefore, be the best man obtainable, and the salary compensation should be adequate to command his entire thought and energy.

Since high-grade talent must be secured in connection with the successful development of the cooperative-marketing system, most organizations have found it advantageous to extend the activities of the institution to the purchase of consumable supplies—in dairy districts, to the purchase of grain and feed; in fruit and truck areas, to the purchase of packages, fertilizers, implements, etc. The object is to provide profitable continuous employment for a competent manager, rather than to attempt to operate on an intermittent plan. Competent executives can not be had except on a permanent basis. It is evident, therefore, that unless the activities are extended few associations will be able to afford high-grade management. All officers' handling moneys for the association should be bonded and made responsible in every possible way.

#### SCOPE OF OPERATION.

The activities of cooperative associations should be extended to cover all important money products of the community, and the territory included should be the extent of the zone or district, as determined by some natural boundary, rather than by arbitrary or community lines. Products which are grown in restricted areas are more easily handled by local exchanges than commodities having a general distribution. With products such as Irish potatoes, cereals, and forage crops, State-wide or district organizations can be made more effective than small local units. The local unit is necessary, but it should be affiliated with and receive its general direction from a central organization, through which the total production of a large area is handled. This will overcome any competition which might arise between small cooperative units. It would prevent the use of methods which, the writer is sorry to say, have been employed by unscrupulous dealers in attempting to disrupt cooperative organizations. Rivalry and competition are not cooperation. Nothing pleases the unscrupulous dealer better than to stimulate competition where there should be cooperation, and nothing is so destructive to the interests of the community as a whole as the competition which

exists where the independent method of action is in vogue and where competition can be stimulated between local cooperative organizations. To avoid this, all local cooperative organizations should affiliate with community-wide or State-wide organizations.

#### SUMMARY.

Experience proves that it is within the power of the producer to cooperate in the sale of vegetable crops to the extent of standardizing the pack and the package and guaranteeing the grade, to reduce the cost of transportation by shipping in carload lots, and to reduce the cost of sales by establishing a reputation for a product, so that it can be sold f. o. b. shipping point.

Cooperative management facilitates business with common carriers and expedites the settlement of claims against both carriers and dealers.

Cooperative action between producers and distributors insures a quicker delivery and decreases the cost to the consumer by saving one freight charge and sometimes also commission or brokerage.

Cooperative interests enable growers to purchase consumable supplies, to secure short-time loans, to provide their own insurance, to conduct a system of crop reporting which will give them an accurate idea of the condition of the crop and of the market at any time, and, when conducted on a broad basis, to prevent depression of the market by unwise distribution and untimely shipments.

## THE CHESTNUT BARK DISEASE.

By HAVEN METCALF,

*Pathologist in Charge of Investigation in Forest Pathology,  
Bureau of Plant Industry.*

### HISTORY AND DISTRIBUTION.

To Mr. H. W. Merkel, forester of the New York Zoological Park, belongs the credit of first clearly recognizing, in 1904, the potential seriousness of the disease now known as the chestnut bark disease or chestnut blight. Observations reported later by other persons indicate that the disease was present on Long Island some years earlier. Apparently the disease has spread from this general vicinity; at least no centers of infection have been found elsewhere which are as old as those about New York City.

The disease is now distributed from Merrimack County, N. H., and Warren County, N. Y., on the north, to Albemarle County, Va., on the south. In New York the western border of distribution, so far as known at present, is sharply delimited by an area without chestnut trees—a natural “immune zone”—which extends southward along the eastern borders of Fulton, Montgomery, and Schoharie Counties nearly to the Pennsylvania line in Delaware County. Consequently in New York the range of the disease is at present practically limited to the valley of the Hudson. In Pennsylvania the western limit of general infection is roughly along a curved line extending from the northwest corner of Susquehanna County to the eastern border of Clearfield County and on to the southwest corner of Fulton County. West of this line the advance infections have been cut out by the Pennsylvania Chestnut Tree Blight Commission. The disease has not yet been found in Ohio or North Carolina. The infections farthest west, most of which have now been cut out, are those in Livingston County, N. Y., Warren and Somerset Counties, Pa., and Randolph County, W. Va. All of these appear to owe their origin to diseased chestnut nursery stock.

It is difficult to estimate the financial loss which the above distribution represents, as we have no exact statistics on the value of

standing chestnut timber. The estimate of \$25,000,000 made in 1911 as representing the loss up to that time was probably much too conservative. But the total loss to date is insignificant compared with the loss which will ensue if the disease once attacks the fine chestnut timber of the South Appalachians. The bark disease has killed all the chestnut trees in those localities where it has been present long enough, and there is not now the slightest indication that it is decreasing in virulence or that the climate of any region to which it has spread is having any appreciable retarding effect upon it.

#### CAUSE AND SYMPTOMS.

The chestnut bark disease is caused by the growth in the bark and outer wood layers of a parasitic fungus, *Endothia parasitica* (Murr.) A. and A.

When any spores of this fungus gain entrance into a wound on any part of the trunk or limbs of a chestnut tree they commonly give rise to a concentrically spreading canker which soon girdles the tree. (Pl. XXXIV.) Not only is the bark and cambium destroyed, but the fungus quickly infects the outer layers of sapwood, penetrating more deeply at the center of the canker. If the part attacked happens to be the trunk, the whole tree is killed, sometimes in as short a time as a single season. If the smaller branches are attacked, only those portions beyond the point of attack are killed, and the remainder of the tree may survive for several years. In Plate XXXVI, figure 3, the lower large limb on the left-hand side is still healthy, as the canker which girdled and killed the rest of the tree is situated on the trunk immediately above this branch. Plate XXXVI, figure 1, shows the ragged appearance of the tree, due to the fact that some branches are not yet girdled and still have normal foliage, while others are dead.

Some of the symptoms are quite prominent. Limbs and trunks with smooth bark which are attacked by the fungus soon show cankers in the form of dead, discolored, sunken areas (occasionally with a raised margin), which continue to enlarge and soon become covered more or less thickly with yellow, orange, or reddish brown spots about the size of a pinhead. (Pl. XXXIV.) These spots are the pustules of the fruiting fungus. Following a rain, or in damp situations, masses of minute spores (conidia) are commonly extruded in the form of long, irregularly twisted strings or horns, which are at first bright yellow to greenish yellow, or even buff, becoming darker with age. If the canker is on the trunk or a large limb with very thick bark there is no obvious change in the external appearance of the bark itself, but the pustules show in the cracks, and the bark often sounds hollow when tapped. After the limbs or trunks

are girdled the fungus continues to grow extensively through the dead bark, sometimes covering the entire surface with reddish brown pustules. These pustules produce mostly the type of spores called ascospores, although occasionally long strings of conidia are also produced, even on bark that has been dead at least a year. If the proper conditions of moisture are present the fungus will continue to grow on the bark of chestnut logs and even upon bare wood.

When a branch or trunk is girdled the leaves above change color and sooner or later wither. (Pl. XXXVII.) These prematurely killed leaves often remain on the branches, forming, together with the persistent burs, the most conspicuous winter symptom of the disease. The most conspicuous symptom at all times of the year is the occurrence of sprouts at the base of the tree, on the trunk, or on the branches. (Pl. XXXV; Pl. XXXVI, figs. 1 and 2; also Pl. XXXVII.) Sprouts may appear below every canker on a tree, and there are often many such cankers. These sprouts are usually very luxuriant and quick growing, but rarely survive their second or third year, as they in turn are killed by the fungus. The age of the oldest living sprout, as determined by the number of its annual rings, is an indication of the minimum age of the canker immediately above. The annual development of sprouts from the base of a tree sometimes continues vigorously for at least six years after the tree is dead, which fact affords clear evidence of the healthy condition of the roots. If infection of these basal sprouts could be prevented, they would develop into a much better type of coppice than is usually seen, since they are rooted in the ground. After the tree is dead the dead sprouts, together with the scars left by cankers on the outer layers of wood, serve to show what killed the tree long after the bark has completely decayed and fallen away.

The fungus apparently does not penetrate to any considerable distance below the ground; nor does it attack the green leaves or the greenest of the young wood. Late in the season it will readily attack wood of the current year. This is observed, however, most commonly on sprouts.

Regarding the virulent parasitism of *Endothia parasitica* there is no possible question. It is easy to demonstrate this by making artificial inoculations in healthy trees. Plate XXXVII shows such an inoculated tree. The conidia, or so-called summer spores of the fungus, were put into a slit in the bark near the base of this little potted chestnut tree and a canker promptly developed. The typical symptoms of the bark disease, as they occur in large trees, followed—girdling of the trunk, withering of the leaves above, and prompt development of sprouts from below the canker. Some weeks after the photograph (Pl. XXXVII) was taken the sprouts were all killed by the downward growth of the canker.

## MEANS OF SPREAD AND INFECTION.

Recent investigations show that the ascospores are commonly ejected during and after a rain, and on account of their small size may be blown by the wind for a distance of at least 50 feet, in spite of their sticky character. The strings of sticky conidia are instantly dissolved by rain, and are washed down over the surface of the tree. It is conceivable that they may be blown by the wind as far as rain or spray is blown or, mingling with dust at the foot of the tree, be blown about with the dust. There is strong evidence that the sticky conidia and ascospores may become attached to the various forms of animal life—insects, birds, squirrels, etc.—which frequent the diseased trees, and so be carried by them to other trees. That the disease is carried bodily for great distances in diseased chestnut nursery stock, unbarked ties, poles, or other timber, tanbark, etc., is a demonstrated fact.

When the spores have once been carried to a previously uninfected tree they may develop in any sort of wound or injury in the bark that is reasonably moist, and produce a canker. There is, indeed, some slight evidence that under certain conditions the fungus may gain entrance through apparently uninjured bark; but it is not necessary to assume that such entrance is common in nature, for the bark of the typical chestnut tree is covered with all sorts of injuries through which the fungus can readily find entrance.

No evidence has been adduced up to the present time to show that a tree with reduced vitality is more susceptible to infection or that the cankers develop more rapidly in such a tree than in a perfectly healthy and well-nourished tree of either seedling or coppice growth, except in those cases where such reduced vitality is accompanied by bark injuries through which spores can gain entrance. Nor has any evidence yet been adduced to show that weather or soil conditions within the present range of the disease exert any appreciable effect upon it, beyond the fact that wet weather in general favors the distribution of the spores.

The American chestnut, the chinquapin, and the cultivated varieties and hybrids of the European chestnut are all subject to the bark disease, although apparently varying in susceptibility. The Japanese, Korean, and Chinese varieties appear to show decided resistance. Unfortunately, these varieties are, so far as known, too small to be of value except as lawn and nut-producing trees. In America true examples of these varieties are rarely seen. What passes in the market as the Japanese chestnut, for example, is almost invariably a hybrid between the Japanese and some American or European variety.

Recently *Endothia parasitica* has been reported on three species of oaks. Although such occurrence appears to be rare, the spread of the bark disease to oak trees presents an unpleasant possibility.

#### LINES OF INVESTIGATION AND CONTROL.

The history of the investigation of the chestnut bark disease with reference to its control is a long story of procrastination. Undoubtedly present on Long Island in the nineties and doing conspicuous damage in the largest city of the United States as early as 1904, the disease is, nevertheless, not mentioned in scientific literature until 1906. It is not mentioned in any economic publication until 1908, and then without any appreciation of its seriousness. The impression was allowed to prevail that the disease was due to weather conditions and would soon disappear of itself, and hence was not worthy of serious attention. So in attempting control of the disease we find ourselves handicapped at every step by lack of knowledge, although there would have been ample time to secure this knowledge if practical investigations had been begun even as late as when Merkel noted the serious character of the disease.

#### CUTTING OUT ADVANCE INFECTIONS.

Many scattered advance infections have been cut out, including all of those in Pennsylvania. That State has taken the lead not only in cutting out advance infections and utilizing dead chestnut trees, but also in all lines of investigation of the disease. The results of this work are awaited with profound interest, not only by such States as Ohio and West Virginia, which are in part protected by the action of Pennsylvania, but also by those more distant Southern States that still have time to profit by the experience of Pennsylvania.

#### UTILIZATION OF DEAD AND DYING TREES.

The utilization of dead and dying trees is a forestry problem of the utmost importance. In the neighborhood of New York City all chestnut trees are dead; as we go from there in any direction we find areas of dead trees, corresponding to old points of advance infection, surrounded by more recently infected trees. Between these areas are occasional "islands" of still healthy trees. But the number of trees that should be immediately utilized is enormous and will increase annually. They should be used to save the timber, to reduce infection, and to prevent possible increase of injurious insects. Since the wood of a diseased tree is rotted only immediately under the cankers, a tree that is cut promptly may be expected to make practically as good timber as a sound tree. However, if

cutting is delayed until long after the tree is girdled, the timber will necessarily be open to the same objections as that from any dead tree.

The Pennsylvania Chestnut Tree Blight Commission has induced certain railroads in that State to make a discrimination in freight rates in favor of products from diseased chestnut trees, which enables these products to be used more cheaply than those of other species. Unless some such plan can be brought about in other States also, it is difficult to see how a great glut in the market for chestnut products can be avoided.

#### IMPROVEMENTS IN FOREST MANAGEMENT.

The work on the bark disease in certain States has been made the occasion of a general forest survey. Everywhere it will result in more careful management of the surviving trees. In localities where the chestnut is already past saving, this species must be discriminated against. While change of management of chestnut woodland may not affect the course of the disease, except in so far as it involves the cutting out of infected trees, constructive forestry is bound to be stimulated by the work done on this disease. Methods of control of this and other forest diseases, which are visionary now, will be in daily use in 20 years. We do not now realize how rapidly forestry in the Eastern States is becoming as intensive as that of Europe.

#### TREE MEDICATION.

The possibility of controlling disease in trees by special fertilization or by direct chemotherapy, that is, by the introduction of chemicals or immunizing substances directly into the tree, has long been a fascinating ideal. The method has been discredited by the number of "fake" remedies which are supposed to be applied in this way. Nevertheless, the basal idea is fundamentally sound. The Pennsylvania Chestnut Tree Blight Commission, in cooperation with the United States Department of Agriculture, is making extensive experiments along this general line. From this work very valuable scientific results are to be expected, whether the method becomes a practical success or not, and the results obtained may be expected to be in some measure applicable to other species of trees, including fruit trees.

#### BREEDING RESISTANT TREES.

The apparent resistance of various Asiatic chestnuts suggests that if resistant individuals of these varieties are crossed with the American and European chestnuts, hybrids might be produced with the desirable nut characters of one parent and the resistance of the other. So far no resistant individuals of the American chestnut have been found. Trees of both American and Asiatic species of the genus *Castanopsis* could possibly also be used as resistant parents, at least





Shull-

A TYPICAL GIRDLING "CANKER" OF THE CHESTNUT BARK DISEASE.



FIG. 1.—COMPLETE DESTRUCTION OF CHESTNUT TREES IN MIXED STAND.



FIG. 2.—CHESTNUT TREES KILLED BY THE BARK DISEASE.  
[Note healthy condition of trees of other species.]

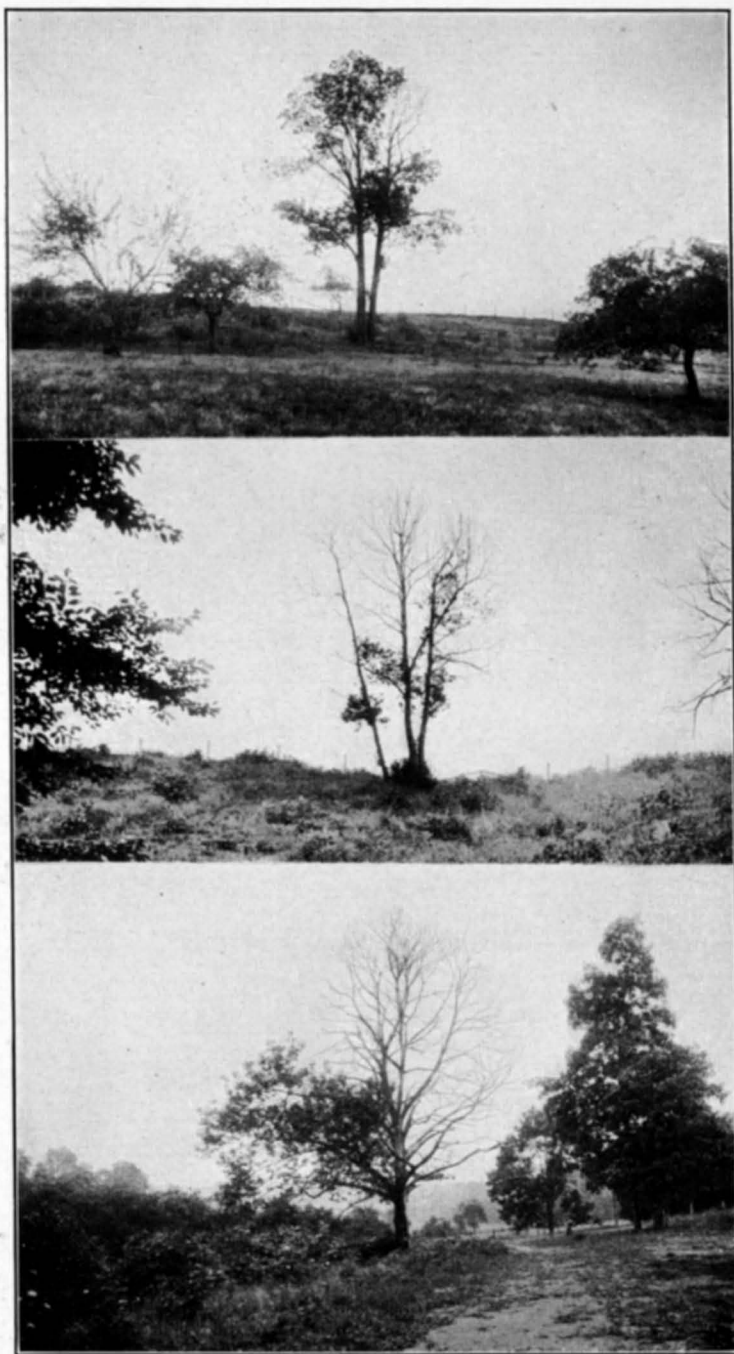

ORNAMENTAL CHESTNUT TREES DYING WITH THE BARK DISEASE.





SMALL CHESTNUT TREE IN POT ABOUT THREE MONTHS AFTER ARTIFICIAL INOCULATION WITH SUMMER SPORES FROM A PURE CULTURE OF THE FUNGOUS PARASITE.  
[Tree girdled at base, leaves above withered; vigorous suckers growing up from below girdled point.]

for trees to be grown in the South. Resistant timber trees, as well as nut trees, could doubtless be produced. Many experiments along this line are already in progress. In the long run the results of breeding will probably be the most profitable outcome of the struggle against the bark disease. Sooner or later we must begin to breed forest trees systematically, and the chestnut is on many accounts a good tree to start with.

## INSPECTION OF DISEASED NURSERY STOCK.

As has been indicated, diseased chestnut nursery stock in the past has been an important factor in the spread of the bark disease. On account of a well-grounded fear of this disease much less chestnut nursery stock is being moved now than formerly, but there is still enough to constitute a serious source of danger. It is therefore obvious that every State in which the chestnut grows, either naturally or under cultivation, should as speedily as possible pass a law putting the chestnut bark disease on the same footing as other pernicious diseases and insect pests, such as peach yellows and the San Jose scale, against which quarantine measures are now taken. Many inspectors already have the legal power to quarantine against the bark disease on chestnut nursery stock, and they should now take special care that no shipment, however small, escapes their rigid inspection.

The most serious practical difficulty in inspecting nursery stock for this, as for other fungous diseases, lies in the fact that practically all State inspectors are necessarily entomologists and are usually not trained in recognizing the more obscure symptoms of fungous diseases. Nursery trees affected by the bark disease rarely show it prominently at the time when they are shipped; the threads of conidia or the yellow or orange pustules are rarely present, and usually all the inspector can find is a small, slightly depressed, dark-colored area of dead bark, usually near the ground, which is easily overlooked or mistaken for some insignificant injury. Upon cutting into such a spot the inner bark shows a most characteristic disorganized "punk" appearance quite different from that of any other bark injury. Occasionally a yellowish brown or reddish band or blotch, either girdling or partly girdling the young tree, may be seen, which is very characteristic.

If infected trees are set out they develop the disease with its characteristic symptoms the following spring. On account of their small size such trees are girdled and die before the end of the summer. Meanwhile they become a source of danger to neighboring orchard and forest trees. Orchardists and nurserymen purchasing chestnut trees are therefore warned to watch them closely during the first season, no matter how rigidly they may have been inspected.

## INDIVIDUAL TREATMENT OF DISEASED TREES.

Where valuable ornamental, shade, or orchard chestnut trees become infected in one or more spots their life and usefulness can be prolonged for several or for many years, depending largely upon the thoroughness with which the recommendations herein given for cutting out the cankers are carried out. Better results will be obtained with small, thin-barked trees than with large ones.

The essentials for the work are a gouge, a mallet, a pruning knife, a pot of coal tar or good paint, and a paint brush. In the case of a tall tree a ladder or rope, or both, may be necessary, but tree climbers should not be used, as they cause wounds which are very favorable places for infection. Sometimes an ax, a saw, and a long-handled tree pruner are convenient auxiliary instruments, though practically all the cutting recommended can be done with a gouge having a cutting edge of 1 or 1½ inches. All cutting instruments should be kept very sharp, so that a clean and smooth cut may be made.

By cutting with the gouge into a diseased area a characteristically discolored and mottled middle and inner bark is revealed. All of this diseased bark should be carefully cut out for an inch or more beyond the discolored area, if the size of the branch will allow it. This bark should be collected in a bag or basket and burned. If the cutting is likely to result in the removal of the bark for much more than half the circumference of the branch or trunk it will probably be better to cut off the entire limb or to cut down the tree, as the case may be, unless there is some special reason for attempting to save the limb or tree. The fungus usually, though not always, develops most vigorously in the inner bark next to the wood. When the disease has reached the wood not only all the diseased bark and an inch of healthy bark around it must be removed, but three or more annual layers of wood beneath the diseased bark must also be gouged out. Special care should be taken to avoid loosening the healthy bark at the edges of the cut-out areas. Except in the early spring, this is not difficult after a little experience in manipulating the gouge and mallet, provided the gouge is kept sharp. Small branches which have become infected should be cut off, the cut being made well back of the diseased spot.

All cut-out areas and all the cut ends of stubs should be carefully and thoroughly painted with coal tar. A good grade of paint has been recommended by some authorities as superior to tar, but it is more expensive. If the tar is very thick the addition of a little creosote will improve it for antiseptic purposes as well as for ease in applying. If the first coat is thin a second one of fairly thick tar should be applied within a few weeks or months. Other coats should be applied later whenever it becomes necessary.

The entire tree should be carefully examined for diseased spots and every one thoroughly cut out and treated in the way described. In case suspicious-looking spots appear, a portion of the outer bark can be cut out with the sharp gouge as a test. If this cut shows the characteristically discolored bark, the spot is diseased and should be cut out accordingly; if the cut shows healthy bark, it need merely be treated with tar or paint, as other cuts are treated. In examining a tree for diseased spots it is always best to begin at the base of the trunk and work up, for if the trunk is girdled at the base it is useless to work anywhere on the tree.

A tree which is being treated for individual infections must be carefully watched and the diseased spots promptly cut out as they appear. For this purpose each tree should be examined very carefully two or three times at least during the growing season. If all the mycelium in the bark and wood has not been removed reinfection is certain to follow.

#### ADVICE TO CHESTNUT ORCHARDISTS.

In view of the uncertain future of the chestnut tree the United States Department of Agriculture advises against planting chestnuts anywhere east of Indiana, at least for the present.

West of the natural range of the American chestnut, however, the situation is quite different. Obviously the western chestnut orchardist has before him a great opportunity. No matter how successful efforts to limit the bark disease may be, the nut crop will be reduced for some years, and the business of growing fine orchard chestnuts in the East will be depressed for the same length of time. There is no apparent reason why, with rigid inspection of purchased stock and of the orchards themselves, all chestnut orchards and nurseries from Indiana to the Pacific coast can not be kept permanently free from the bark disease; therefore, all persons interested in growing the chestnut in the West are earnestly advised to be sure that stock from any source is rigidly inspected, to watch continually and with the utmost care their own nurseries and orchards, and to destroy immediately by fire any trees that may be found diseased.

#### ADVICE TO OWNERS OF ORNAMENTAL CHESTNUT TREES.

Until the future of the chestnut tree is better known, the owners of chestnut-timbered land available for building should pursue a very conservative policy. Houses should not be located with sole reference to chestnut groves or to isolated ornamental chestnut trees. Buyers of real estate should discriminate against houses so located in so far as the death of the chestnut trees would injure the appearance of the place.

When ornamental trees become diseased they had better be cut down at once and, if practicable, large trees of other species moved in to take their places. In expert hands the moving of large trees is a perfectly practicable and successful procedure and, although more expensive, is much more satisfactory than waiting for nursery trees to grow.

#### ADVICE TO OWNERS OF CHESTNUT WOODLAND.

Owners of chestnut woodland that is thoroughly infected are advised to convert their trees into lumber as soon as possible. The trees which are not already killed will soon die in any case, and the timber rapidly deteriorates in quality. Such trees are a continual source of infection.

Owners of chestnut woodland outside the area of general infection are counseled to watch for the first appearance of the disease and when it appears to cut down immediately all affected trees, bark them, and burn the bark and brush, over the stump if practicable. Such procedure will distinctly retard the spread of the disease in that particular woodland, even if no concerted efforts at elimination are made by neighboring owners or by the State.

It is almost needless to add that with the present outlook chestnut woodland is a poor investment. Furthermore, in forest management, as in improvement cuttings, etc., there should be discrimination against the chestnut.

#### THE OUTLOOK.

Disease is expected in cultivated plants, grown as they are under unnatural conditions and usually in a strange environment; but a fungous disease as serious as this, attacking a hardy native tree over hundreds of square miles in the heart of its natural range, is, so far as known, without precedent. It is, then, idle to attempt to prophesy what will be the future course of the disease. But whatever the outcome is, we may be sure that the results of the study of this disease will in the end justify all present efforts. We may be certain that this is not the last devastating disease of forest trees to appear, and in the future we shall need all the knowledge and experience that can be gained from this malady. With the increase in the value of timber and with the rapid development of intensive forestry, methods now impracticable for controlling tree diseases will come into regular use, and the practicable methods of the future can only be developed by years of scientific research and field experience on a large scale.



## SOME USEFUL WEATHER PROVERBS.

By W. J. HUMPHREYS, Ph. D.

*Professor of Meteorological Physics, United States Weather Bureau.*

It can be argued, of course, and apparently with good reason, that weather proverbs can not now have any practical use, since nearly every country has a national weather service whose forecasts, for any given time and place, are reliably based upon the known immediately previous conditions all over a continent—conditions that are followed from hour to hour and day to day; that are minutely recorded and carefully studied.

It is true that when one is supplied with such information his horizon becomes world-wide; that he sees the weather as it is everywhere; knows in what directions the storms are moving and how fast, and that therefore he can predict the approximate weather conditions for a day or more ahead. But in general it is not practicable officially to forecast for definite hours nor for particular farms and villages. In the making, then, of hour-to-hour and village-to-village forecasts, though often of great value, one must rely upon his own interpretation of the signs before him. Besides, in many places it is impossible to get, in time for use, either the official forecast or the weather map upon which to base one's own opinions, and under these conditions certain weather signs are of especial value—signs which everyone uses to a greater or less extent but with an understanding of their significance that, according to such experience as only real necessity can give, varies from the well-nigh full and complete to the vague and evanescent.

Thus the fisherman to-day, as in the past, will weigh anchor and flee from the gathering storm when to the uninitiated there is no indication of anything other than continued fair weather; and the woodsman, as did his remotest ancestors, will note significant changes and understand their warning messages when the average man would see no change at all, or if he did, would fail to comprehend its meaning.

The prescience of these men is phenomenal, and it is with some of the useful weather proverbs they know so well, the causes of the phenomena they describe, and the relation of these phenomena to others they precede that the following is concerned.

#### THE SEASONS.

Naturally everyone asks: "What of the coming season?" And especially is this an important question for the farmer, for a correct answer to it would tell him what crops to plant and where; whether upon hill or lowland, in light or heavy soil, and how best to cultivate them—vital points, every one, for his success. But whatever we may hope ultimately to accomplish, seasonal forecasting to-day is beyond the pale of scientific meteorology, though proverb meteorology is full of it. However, a few of the seasonal proverbs that deal with results rather than types of weather are rationally founded. Among them we have:

Frost year,  
Fruit year.

Year of snow  
Fruit will grow.

Or, in still another form:

A year of snow, a year of plenty.

That these and similar statements commonly are true is evident from the fact that a more or less continuous covering of snow, incident to a cold winter, not only delays the blossoming of fruit trees till after the probable season of killing frosts but also prevents that alternate thawing and freezing so ruinous to wheat and other winter grains. In short, as another proverb puts it,

A late spring never deceives.

A different class of proverbs, but one meaning practically the same thing as the foregoing and justified by substantially the same fact—that is, that an unseasonably early growth of vegetation is likely to be injured by later freezes—is illustrated by the following examples:

January warm, the Lord have mercy.

If you see grass in January,  
Lock your grain in your granary.

January blossoms fill no man's cellar.

January and February  
Do fill or empty the granary.

There are hundreds of other proverbs dealing with seasonal forecasts, but, except those belonging to such classes as the above, they have very little to justify them. Many are purely fanciful and others utterly inane.

#### THE SUN.

While proverbs concerning the seasons, in the most part, are built upon the shifting sands of fancy and of superstition, many, but not all, of those that concern the immediate future—the next few hours or, at most, the coming day or two—are built upon the sure foundation of accurate observation and correct reasoning. Among these perhaps the best are those that have to do with the color of the sky and the appearances of the sun, the moon, and the stars, for we see the first because of our atmosphere and the others through it, and therefore any change in their appearances necessarily means changes in the atmosphere itself—changes that usually precede one or another type of weather. A familiar proverb of this class runs as follows:

A red sun has water in his eye.

Now, the condition that most favors a red sun is a great quantity of dust—smoke particles are particularly good—in a damp atmosphere. Smoke alone in sufficient quantity will produce this effect, but it is intensified by the presence of moisture. The blue and other short-wave-length colors, as we call them, of sunlight are both scattered and absorbed to a greater extent by a given amount of dust or other substances, such as water vapor, than is the red; and this effect becomes more pronounced as the particles coalesce. Hence when the atmosphere is heavily charged with dust particles that have become moisture-laden we see the sun as a fiery red ball. We know, too, that this dust has much to do with rainfall, for, as was first proved many years ago by the physicist Aitken, cloud particles, and therefore rain, will not, under ordinary conditions, form in a perfectly dust-free atmosphere but will readily form about dust motes of any kind in an atmosphere that is sufficiently damp.

A red sun, therefore, commonly indicates the presence of both of the essential rain elements—that is, dust and moisture; and while the above is not the whole story, either of the meteorological effects due to dust in the air or of the formation of rain, it is sufficient to show how well founded the proverb under consideration really is. And also this other one, that says:

If red the sun begin his race,  
Be sure the rain will fall apace.

## SKY COLORS.

There are many proverbs, ranging from the good and useful to the misleading and absurd, concerning the color of the sky at sunrise and sunset. From Shakespeare we have the well-known lines:

A red morn that ever yet betokened  
 Wreck to the seamen, tempest to the field,  
 Sorrow to the shepherds, woe unto the birds,  
 Gusts and foul flaws to herdsmen and to herds.

Besides these stately verses, there are many proverb jingles that express substantially the same idea. One of them puts it thus:

Sky red in the morning  
 Is a sailor's sure warning;  
 Sky red at night  
 Is the sailor's delight.

But in many ways the most interesting of all those proverbs that have to do with red sunrise and red sunset is the one which, according to Matthew, Christ used in answer to the Pharisees and Sadducees when they asked that He would show them a sign from heaven.

He answered and said unto them, When it is evening, ye say, It will be fair weather: for the sky is red.

And in the morning, It will be foul weather to-day: for the sky is red and lowering.

It will be noticed that an evening red is here declared to indicate exactly the opposite type of weather from that indicated by a morning red. This, however, is only an apparent contradiction, for the origin of the red is not the same in the two cases; but the full explanation of the physical difference, while well known, is too long to include here.

If the evening sky, not far up, but near the western horizon, is yellow, greenish, or some other short wave-length color, then all the greater is the chance for clear weather, for these colors indicate even less condensation and therefore a dryer air than does red. Hence we can accept the following lines from Shakespeare as the expression of a general truth:

The weary sun hath made a golden set,  
 And by the bright track of his fiery car  
 Gives token of a goodly day to-morrow.

If, however, the evening sky has none of these colors, but is overcast with a uniform gray, then we know that numerous water droplets are present, and that the dust particles, in spite of the heat they absorbed from sunshine, have become loaded with much moisture. Obviously, then, to produce this effect the atmosphere, at considerable

elevations, must be practically saturated, a condition that favors rain and justifies the familiar proverbs:

If the sun set in gray  
The next will be a rainy day.

If the sun goes pale to bed  
'Twill rain to-morrow, it is said.

Additional good examples of weather proverbs based on sky colors are as follows:

Evening gray and morning red  
Make the shepherd hang his head.

An evening gray and a morning red  
Will send the shepherd wet to bed.

Evening red and morning gray  
Two sure signs of one fine day.

Evening red and morning gray  
Help the traveler on his way;  
Evening gray and morning red  
Bring down rain upon his head.

#### CORONAS AND HALOS.

Many proverbs foretelling rain and bad weather are based on the appearance of solar and lunar halos and coronas, and as these form only when there is much moisture in the air and some condensation, the proverbs of this class are well founded.

Coronas are the small colored rings of light that encircle any bright object when seen through a mist, though the term commonly is used to designate only the colored rings around the sun and moon. They are due to diffraction (the bending of light at the boundary of an object into its geometric shadow) caused by water globules, and have one or another angular diameter, depending on the size of the droplets that produce them, in the sense that the larger the droplets the smaller the corona. Hence a decreasing corona implies growing drops and the probability of an early rain.

Halos, on the other hand, are the rings of large diameter, usually colorless or nearly so, due to reflection and refraction by ice spicules, and are often seen in the high cirrus clouds that have been caught up from the tops of storms and carried forward by the swiftly moving air currents that always prevail at such elevations. It is this usual position of halos relative to storm centers—that is, in front of them—that makes them the good indicators they are of approaching bad

weather. Typical of such proverbs is that of the Zuñi Indians, who say:

When the sun is in his house it will rain soon.

Several others refer to the apparent diameter of the circle. Thus we have:

Far burr, near rain.

The bigger the ring, the nearer the wet.

When the wheel is far the storm is n'ar;

When the wheel is n'ar the storm is far.

These latter can not refer to the corona, which actually does change in angular size, because in that case just the reverse is true; the bigger the ring the farther off the storm. Clearly, then, they apply only to the halo, and as the apparent size of an object of constant angular diameter depends upon its seeming distance away, it follows that the supposed changes referred to are optical illusions, due to erroneous impressions of distances. A good illustration of this kind of illusion is furnished by the moon as seen by different people, or as seen by the same person at different elevations above the horizon. When high in the heavens, where it appears to be comparatively near, it looks smaller than it does when close to the horizon, where it seems to be farther away; and yet careful measurements show but little change in its angular diameter, and that little just the reverse of appearances.

Hence, when the actual distance to a halo is less than it seems to be, as often happens when the clouds are low, it appears to be unusually large; and, conversely, when the clouds are very high a halo in them, because the distance to it commonly is underestimated, impresses one as being correspondingly small. Now, the higher the clouds the swifter the winds that carry them along and the farther removed they become from the storm center. Hence, a halo that appears small is due to clouds far removed from the storm that produced them, while one that seems large, since it is caused by relatively low and therefore slow-moving clouds, usually indicates that the storm is comparatively near.

#### THE MOON.

Many people have supposed, and some still hold, that the moon appreciably controls the weather, and there are numerous proverbs based on this assumed relation. But careful study of the records shows that the moon's influence on the weather, beyond a very small tidal effect on the atmosphere, as indicated by the barometer, is

negligible, if indeed it has any influence at all. As has been well said:

The moon and the weather  
 May change together;  
 But change of the moon  
 Does not change the weather.  
 If we'd no moon at all,  
 And that may seem strange,  
 We still should have weather  
 That's subject to change.

However, the appearance of the moon depends upon the conditions of the atmosphere, and, therefore, proverbs based upon phenomena of this nature are more or less sound and have much value. Thus,

Clear moon,  
 Frost soon,

Moonlit nights have the heaviest frosts,

and others of this class are true enough, because on the clearest nights the cooling of the earth's surface by radiation is greatest, and hence most likely to cause, through the low temperature reached, precipitation in the form of dew or frost.

The meaning of halos and coronas about the moon has already been explained, and the proverbs connected with them foretelling bad weather fully justified.

The following is a somewhat interesting moon proverb:

Sharp horns do threaten windy weather.

When the air is clear, bad seeing is due to atmospheric inequalities which the free mixing caused by winds will eliminate. When the moon's horns, then, appear sharp—that is, when the seeing is good—we know that these inequalities do not exist, and the natural inference is that they have been smoothed out by strong overrunning winds, which later may reach the surface of the earth.

#### THE STARS.

The stars, like the sun and the moon, have furnished a number of proverbs concerning the weather, and, while most of them are only nonsense, a few have decided merit, as, for instance,

When the stars begin to huddle,  
 The earth will soon become a puddle.

This proverb furnishes, in general, a correct forecast. It also affords a curious illustration of the ignorance that once was—perhaps it would not be far wrong to say still is—so prevalent in regard to stars.

When a mist, due to the beginning of condensation, forms over the sky the smaller stars cease to be visible, while the brighter ones shine dimly with a *plur* (really a faint corona) of light about them, each looking like a small, confused cluster of stars. Hence the idea, as above expressed, that stars can huddle together at one time—before a rain—and be scattered asunder at another.

There is also some ground for the proverb that declares the number of stars within a lunar halo to be the number of days before a storm, for the nearer the storm the denser the condensation, and therefore the smaller the number of stars seen through it. However, as an entire day is a pretty long unit of time to use in sign forecasting, it would be better simply to say that the fewer the stars within the ring the nearer the rain, though even in this form it is not very trustworthy, owing to the fact that the brighter stars are unevenly distributed.

An entirely different star phenomenon that has given rise to a few proverbs is twinkling, or the irregularities with which they shine. This fluctuation in their light is caused mainly by irregular refraction, due to numerous inequalities in the distribution of temperature, such as necessarily accompanies the over and under running of air currents of different temperatures and different humidities, a condition that often precedes a storm. Hence the justification of the prosaic proverb that says:

When stars flicker in a dark background rain or snow follows soon.

#### THE WIND.

There are numerous proverbs based on the directions and changes of the wind, but their value, in the main, is only local, except when taken in connection with the height and rate of change of the barometer. However, in middle latitudes the direction of ordinary undisturbed winds is from west to east. Therefore a radically different direction commonly indicates an approaching, or, at any rate, not very distant storm. There is, then, some justification for such proverbs as the following:

When the smoke goes west,  
Gude weather is past;  
When the smoke goes east,  
Gude weather comes neist.

When the wind's in the south,  
The rain's in its mouth.

The wind in the west  
Suits everyone best.



## THE CLOUDS.

The height, extent, and shapes of clouds depend upon the humidity and upon the temperature and motion of the atmosphere, and consequently they often furnish reliable warnings of the coming weather. One proverb correctly says:

The higher the clouds, the finer the weather.

The formation of clouds is caused mainly by cooling due to convection, the rising mass of air expanding and losing heat because of the work it does in lifting the weight that presses upon it. Now, the greater the height reached the colder, correspondingly, is the air, and hence we correctly infer that high clouds are formed only at the expense of much cooling, and therefore that the amount of moisture they contain can not be great enough to produce falling or bad weather.

This proverb must be restricted to stratus and other of the more common clouds. It does not apply to those thin wispy or cirrus clouds, the highest of all, that float from 5 to 8 miles above sea level, for, as everyone knows:

Mackerel scales and mares' tails  
Make lofty ships carry low sails.

Part of the air that forms the strong upward currents near the center of a storm rises to great heights, where, in middle latitudes, it gets into the swiftly eastward-moving layers that carry it and its ice particles far ahead of the rains. There are other ways by which such clouds can be formed, but that just explained is one of the most common, and as in this case they are only the overrunning portion of a storm that is coming on in the same general direction, the proverb just quoted evidently is well founded.

When the air is rather damp and the day is warm, great cumulus or thunderhead clouds are apt to form, as a result of strong convection, and produce frequent local showers. Hence the following proverb:

When clouds appear like rocks and towers,  
The earth's refreshed by frequent showers.

Another interesting phenomenon, familiar to all who live among the mountains, is the formation of a cloud along the highest ridges, due, of course, to the upward deflection of the wind as it blows against their sloping sides. This mechanical or forced convection produces the usual cooling, which, when the air is damp, results in the formation of cloud. Hence the truth of the proverb that tells us:

When the clouds are upon the hills,  
They'll come down by the mills.

## SOUND.

When the air is full of moisture its temperature tends rapidly to become equalized; the colder places are warmed by condensation and the warmer cooled by evaporation. In this way the atmosphere is freed from the innumerable temperature irregularities that prevail during dry weather, irregularities that, as Tyndal showed many years ago, strongly reflect and dissipate sound. We see, then, that when the air is homogeneous, which it is far more likely to be when damp, it will convey sound much better than it will when filled with inequalities, and hence there is good reason to accept the proverb, and other similar ones, that says:

Sound traveling far and wide  
A stormy day will betide.

Not only the hearing, but the seeing as well, is improved by the homogeneity of the atmosphere; and this, too, has its appropriate proverbs, of which the following is a good example:

The farther the sight the nearer the rain.

## MISCELLANEOUS.

Under this heading one could include a great variety of proverbs—mostly foolish. However, there are two causes, decrease in atmospheric pressure and increase in humidity, that have led to a number of well-founded proverbs, or rather accurate observations, for they are seldom jingled in the typical proverb manner.

Thus we find it stated that the approach of a storm is marked by the rising of water in wells, by the more abundant flow of certain springs, by the bubbling of marshes, by the bad odors of ditches, and by various other phenomena, all of which are due to that decrease of atmospheric pressure that ordinarily precedes a storm.

The increase of humidity—favorable to precipitation—is noted by the gathering of moisture on cold objects, the collection of perspiration on our own skins owing to diminished evaporation, and the dampness of many hygroscopic substances. The last effect is illustrated by the packing of salt, the tightening of cordage and of strings of musical instruments, the dull or damp appearance of stone walls and columns, the settling of smoke, and by a number of other similar phenomena, all of which have been appealed to, with more or less justification, as evidence of a gathering storm.

Of course, many other weather proverbs, of which those quoted in this article are typical, might be given and explained, but it is hoped that enough from each class have been justified to indicate their importance in all those cases and circumstances where, unfortunately, a weather service can not take the place of weather signs.

# SOME IMPORTANT INSECT ENEMIES OF LIVE STOCK IN THE UNITED STATES.

By F. C. BISHOPP,  
*Bureau of Entomology.*

## HOW INSECTS AFFECT LIVE STOCK.

Although, ordinarily, the insect enemies of live stock do not cause death of animals or even complete disability, the damage is by no means inconsiderable, and the watchful care of the stockman is essential to prevent even more serious loss. Death may be produced either by direct attack, by the introduction of disease germs into the animal through bites, or by accidental self-destruction caused by worry. Animals may be so weakened as to cause certain mild or latent diseases to become acute. Loss of weight and reduced productiveness may be caused by worry, or loss of blood, or both.

The ticks and mites are among the foremost enemies of domestic animals. The former are important as parasites, and one of them, the North American cattle tick, acts as the sole transmitter of splenic or Texas fever in cattle. Among the mites two forms are especially injurious to live stock, one of these producing the well-known sheep scab and the other causing mange in cattle. Among the true insects there are in the United States about 200 species which commonly attack domestic animals. It will be possible to discuss only a few of the more important ones in this article.

The flies constitute by far the most important insect enemies of animals in this country and throughout the world. Most of our injurious species have been introduced from other countries, and many of them have practically a cosmopolitan distribution. The traffic in live stock between practically all parts of the world, together with the rapid-breeding and free-flying habits of most of the flies, has made possible the fast spread and wide distribution.

### THE BUFFALO GNAT.

(*Simulium pecuarum* Riley.)

The buffalo gnat, so called on account of its resemblance in shape to a buffalo, is a widely distributed insect. It has been found to occur in Alaska and throughout the eastern half of the United States, but it has not been known to appear in great numbers outside of the Mis-

Mississippi Valley from southern Illinois to about the mouth of the Red River in Louisiana. In this region it has been a dreaded pest to live stock, at least since the early fifties. Outbreaks have been recorded in 1861, 1862, 1863, 1864, 1866, 1868, 1872, 1873, 1874, 1881, 1882, 1883, 1884, 1886, and 1887.



FIG. 11.—Larva of buffalo gnat (*Simulium peculiarum*). Much enlarged. (From Riley.)

All domestic animals are attacked by these gnats, though mules are more likely to succumb to the attacks than are horses and cattle. Animals with long, shaggy hair are most susceptible to attack, as the insects crawl beneath the hair, which offers protection and aids them in clinging to the animal. Cattle are greatly annoyed, lose flesh, and the milk supply is greatly reduced and in some cases rendered unfit for consumption. Hogs and poultry are often killed, or if not, their growth is materially affected. Even man is not exempt from attack.

The buffalo gnats are very dark-grayish insects about one-sixth of an inch in length and of peculiar form, as shown in figure 12. They are strong fliers and when abundant appear in swarms. The females only are fitted with piercing mouthparts.

The species breeds in running water, preferably where the current is strong. The eggs are placed on various objects, such as trees, logs, and shrubs just above the water level. They hatch within a very short time, and the young larvæ enter the water. The larvæ are peculiar looking objects (fig. 11), elongate in shape and rather less than one-half inch in length when full grown. When growth is complete they transform beneath the water to the pupal or resting stage, which lasts about 10 days. There is but one generation a year. The adults emerge during the first warm spring days and soon afterwards deposit their eggs. The

The buffalo gnats are very dark-grayish insects about one-sixth of an inch in length

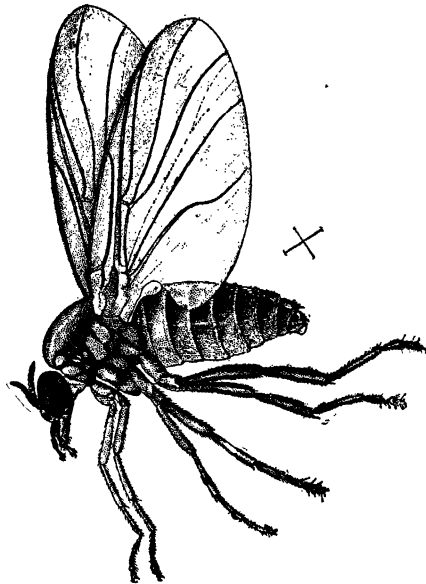

FIG. 12.—*Simulium peculiarum*, one of the buffalo gnats: Adult. Much enlarged. (From Riley.)

resulting larvæ develop slowly and only reach maturity the following spring. The outbreaks vary in duration from a few days to over a month and usually occur in March and April.

The infrequency and lessened severity of outbreaks during the last 15 years well illustrates the value of the improved and extended levee system along the Mississippi and its tributaries in the control of this insect. In addition to the improvement of the levee system, clearing out logs and débris in stream beds reduces the number of places for attachment of the larvæ and thus somewhat reduces the possibilities for breeding.

The destruction of larvæ is impractical, except in small streams, where phenotas oil has been shown to be quite effective. Work animals should be kept in good condition, the rough-haired ones being clipped early in the spring. The maintenance of smudges around fields and in barnyards, and the application of mixtures of fish oil and oil of tar, greases, or substances such as sirup, mud, or resinous combinations, which coat the animals, are valuable in protecting them from the swarms of gnats. Dark stables also afford protection. Where the attack has been so severe as to produce grave symptoms, relief may be secured by immersing the animals in running streams or rubbing them with water of ammonia, as well as by administering carbonate of ammonia and whisky at 3 or 4 hour intervals.

#### THE TURKEY GNAT.

(*Simulium meridionale* Riley.)

The distribution of the turkey gnat, like that of the preceding species, is very wide. The insect occurs in practically all the eastern and southern States from New Hampshire south to Texas and New Mexico. In many cases this and the preceding species have been known to swarm at the same time and attack animals simultaneously. In addition to the dates of invasion given under the discussion of the preceding species, Professors Webster and Newell noted the occurrence of this species in abundance in Wayne County, Ohio, during May, 1901, and Dr. W. E. Hinds recorded the appearance of turkey gnats in injurious numbers in Alabama in April, 1912.

The species derives its common name from the fact that it is a severe pest to turkeys. It is usually not such an important pest to the larger domestic animals as is the buffalo gnat, but poultry are often killed by it, and man is greatly annoyed. In Virginia, where this insect is known to cause thousands of dollars worth of damage to poultry nearly every year, the effects of its injury have been described as a more or less chronic illness which ultimately terminates in death. Brooding chickens and turkeys usually leave their nests,

and in many cases where relief is not secured the poultry succumb within a very few hours.

The flies of this species are somewhat smaller than those of the buffalo gnat. The life history of this insect is not greatly different from that of that species, but its breeding is confined mainly to the smaller, more rapid streams. The development of the larvæ requires about a year, thus permitting of only one generation each season. In general, the swarms of this insect occur later in the spring than do those of the buffalo gnat. They usually appear during April and early May, but have been found as late as the middle of June.

The same preventive and remedial measures recommended for the buffalo gnat are for the most part applicable to this species.

#### HORSEFLIES, GADFLIES, AND EARFLIES.

The members of the group of horseflies are distributed throughout all portions of the United States and are known to every stockman. Some of the species are widely distributed, while others are more or less restricted in their range. Their life history and habits are varied, but the methods of attack and many of the methods of control are similar. There are about 150 species of this family in the United States. The females are all provided with long, piercing mouth parts which inflict painful wounds. During their rapid darting flight they produce a buzzing which often terrorizes nervous animals. While their bite is painful, it appears that the after-effects are less severe than in the case of mosquitoes, gnats, and many other insects. In wooded districts, especially near streams and ponds, these flies often become very serious annoyers of live stock, and although seldom numerous enough actually to cause the death of animals, the constant worry produced by their biting results in loss of flesh and milk production in cattle and a lowering of the condition of horses.

One of the most widely distributed and familiar forms of this group is the black gadfly (*Tabanus atratus* Fab.). This fly does not often appear in great numbers, but its large size and long beak make it a pest which is dreaded by all live stock. Among the smaller horseflies are several species which are very widely distributed and the most numerous of the group. These insects are commonly known as "green-heads." The two species *Tabanus costalis* Wied. and *T. lineola* Fab. (Pl. XXXIX, fig. 5) are among the most important of this group. They are about three-fourths of an inch in length and of gray color. A number of reports have been made of the death of animals caused by these insects, but this appears to be of rare occurrence. Prof. C. E. Sanborn states that in 1896 and 1897 there was a severe outbreak in the northern part of Oklahoma. In this instance the flies were so numerous that harvesters were compelled to run

mainly at night or to have smudges about the fields to protect the teams.

There is little doubt that members of this family are concerned in the transmission of certain blood diseases of live stock. Among the most important of these is the very deadly disease known as anthrax.

The habits of the larvæ of these species, of breeding in water and mud, render their control in this stage very difficult. Numerous repellent substances have been tried with greater or less success against the attack of the flies. Among those which have been recommended are train oil and other malodorous substances. The protective power of all of these is, however, of short duration. The adults are known to have a habit of flying down to the surface of pools of water to drink. Many flies may be killed by covering the water in such pools with a film of kerosene. The use of horse nets aids greatly in the protection of animals which are used for work purposes. Where the earflies abound the net should be made to cover the ears as well as the rest of the body.

#### BOTFLIES.

Among the most important of the flies are the bots of horses, cattle, and sheep. All of these insects are almost world-wide in their distribution. In the United States horses are attacked by three distinct species, cattle by one species, and sheep by another.

By far the most common of the species attacking horses is known as *Gastrophilus equi* Clark. The principal injury is caused by the attack of the larval stage in the stomach of the animal. (See Pl. XXXVIII, fig. 3.) Where the bots become very numerous there is no doubt that digestion is impaired and a considerable loss is due to the quantity of food required to supply the larvæ as well as to the irritation produced by their attack. In some cases they have been known to become so numerous at the exit of the stomach as to stop the passage of food and thus kill the animal.

The female of this species (Pl. XXXVIII, fig. 2) is about three-fourths of an inch in length, with a very hairy body and rather long, pointed abdomen. The fly sticks its eggs to the hair of the host (Pl. XXXVIII, fig. 1). The young larvæ seem to become fully matured within the eggs in about two weeks. At this time the end of the eggshell comes off readily when the animal touches it with its tongue, and the larva is thus swallowed and attaches itself to the lining membranes of the stomach. The development of the larva proceeds slowly through the fall, winter, and following spring, when it becomes fully grown and releases its hold. It passes out with the excrement and soon transforms to the pupal or resting

stage, either in the manure or in the ground beneath it. It is several weeks before this stage transforms into an adult fly.

Remedial measures thus far tried have not been altogether satisfactory. Various oils have some value in repelling the flies at the time of egg laying. The use of certain substances, such as one of the creosote dips or weak carbolic acid, rubbed over the eggs at two-week intervals destroys many of the young larvæ within the eggs. A better plan, however, in the case of animals which are handled frequently, is to keep the eggs groomed off with the currycomb, or to cut off the hair with clippers, or to scrape the eggs off with a sharp knife. Where it is suspected that horses are heavily infested with bots certain substances may be used to cause their expulsion. There is no doubt that where poultry have access to the fresh droppings a large percentage of the bots is destroyed by them.

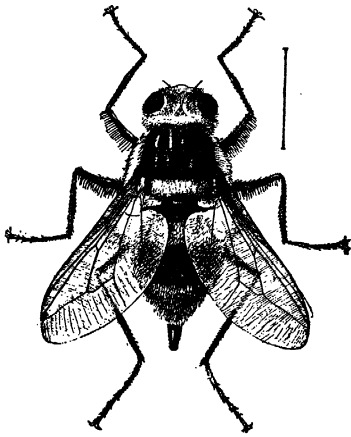

FIG. 13.—The ox bot or heel fly (*Hypoderma lineata*): Adult. Enlarged. (From *Insect Life*.)

The losses due to the ox bot or heel fly (fig. 13) are brought about in several ways. The damage to hides is probably the most important, hides offered for sale being discounted from 25 to 50 per cent, according to the amount of infestation. Cattle frequently destroy themselves by entering mire holes in an endeavor to escape from the worryment caused by the presence of the adult in depositing eggs and the pain produced by the larvæ (Pl. XXXIX, fig. 6) when escaping from the skin. Another important source of loss is the dimi-

nution of the milk supply, as well as the reduction in the flesh of the animals. Prof. Herbert Osborn has estimated the loss due to this pest at \$2.50 per head. This would make a total loss of \$173,596,895 in the United States, based on the total number of cattle as given in the 1900 census.

The life history of this species is quite different from that of bots attacking horses. By a careful investigation of this botfly Dr. Cooper Curtice found that infestation is brought about by larvæ which are taken in on the tongue of the host when licking itself. The young larvæ penetrate the lining membranes of the esophagus and work their way through the muscles until they ultimately reach the region of the back, where they form small tumors and grow quite rapidly to full size. The larva cuts a hole through the skin and, when fully grown, wriggles its way out, drops to the ground, and, after burrowing into it a short distance, transforms to a pupa, from which



an adult fly emerges in a few weeks. There is but one generation of this insect annually. In the South, at least, the eggs are usually laid in the spring or early summer. The early stages of the larvæ prior to their reaching the subcutaneous tissue of the back are of long duration, the grubs usually becoming noticeably large under the skin in the late fall. Emergence from the skin appears to continue from about the first of January to the first of June, according to latitude.

Repellent substances have been recommended as a means for preventing adult flies from depositing their eggs on cattle. Some authorities, however, have found this to be of very little value, and it is not practical on the large ranges in the West. Where cattle are stabled the introduction of a little kerosene or mercurial ointment in openings through which the larvæ breathe has been found to destroy them when they are small. Another method is to squeeze the grubs out and kill them. Should these practices be followed carefully for a few years there is no doubt that the number of warbles would be greatly reduced.

The sheep bot or head maggot (*Estrus ovis* L.) is the most important insect pest with which sheepmen have to deal. This insect is of world-wide distribution and occurs quite commonly on all of the sheep ranges in the United States and Mexico. Loss due to this bot has been much confused with that caused by gid or staggers, which is produced by a parasitic worm. It is therefore difficult to estimate the amount of damage chargeable to this pest. The symptoms are more or less severe, according to the number of grubs in the head of the host, a few being considered of practically no importance. The trouble arises mainly from the irritation to the mucous membranes in the upper nasal regions produced by the hooks or spines with which the larvæ are covered. The larvæ feed on the mucous membranes as well as upon the secretions from them, and there is no doubt that in some cases suppuration is produced and the bone may be destroyed so as to allow the grubs to reach the brain.

The adult flies of this species deposit living maggots in the nostrils of the sheep, mainly during June and July. These larvæ work upward through the nasal passages into the sinuses. When full-grown the larvæ work their way out through the nose and enter the ground for pupation. The adult fly emerges a month or two later.

Preventive practices which have their advocates are the placing of tar on the nose of the sheep and the upturning of soft dirt in pastures in which the sheep may bury their noses to escape the flies. When sheep become infested the larvæ are often expelled by sneezing. This may be induced by the use of lime dust. Where valuable animals are infested it is best to have the larvæ removed by a veterinarian, who usually accomplishes it by trephining the skull.

## THE HORN FLY.

*(Lyperosia irritans L.)*

The horn fly is one of the most widespread and injurious insects in this country. It was introduced into the United States between 1885 and 1887, and its spread has been exceedingly rapid. In 1889 it had invaded most of New Jersey and a considerable part of Pennsylvania, Maryland, and Virginia. New York, Ohio, Kentucky, Georgia, and Mississippi became infested about 1891, and in 1892 the insect had spread northward to Connecticut and Canada and westward to Michigan, Ohio, Indiana, Iowa, Louisiana, and Texas. Apparently it was first recorded from Colorado in 1894. Prof. W. B. Herms states that as nearly as he can determine the fly reached California in 1895. Two years subsequently it was transported with live stock to Hawaii, where it soon became a serious pest. Its spread northwestward appears to have been slower. Prof. J. M. Aldrich states that it reached Idaho in 1901, and there are certain sections in Montana where the fly has become established within the last two or three years.

This insect (Pl. XXXIX, fig. 7) is related to the house fly, but it is smaller and provided with lancelike mouth parts. The ox is its principal host, although the horse is sometimes quite severely attacked. The losses sustained are entirely due to the worryment and irritation produced by the bites of the fly and by extraction of blood. This worryment results in loss of flesh and great reduction in milk production. Sores are sometimes produced by it which may become infested with screw worms.

In the Southwest the flies usually become very abundant in the spring and again in the fall, the hot summer weather checking breeding. Rainy springs and falls are the most favorable and cause the insects to appear in greater numbers. The flies spend the greater part of their existence on the animal, leaving only for a few seconds at a time to deposit eggs in freshly dropped cow manure, in which the larvæ develop rapidly. They usually work downward to the surface of the earth and there transform to reddish-brown pupæ, from which the adult flies emerge in from 10 to 20 days from the date the eggs were deposited.

Under ordinary conditions, and where few animals are kept on the farm, breeding can be largely prevented by scattering the manure every three or four days. This allows it to dry out and thus prevents development of immature stages. The use of manure spreaders has been found to be well adapted for the distribution of manure from dairies or farms where a considerable amount of it is accumulated. Where animals are under control repellent substances, such as train oil, placed on the parts most attacked have given fair satis-

faction. All such substances have to be applied at frequent intervals, thus entailing much trouble and expense. It has been found that where dipping of cattle is practiced against the Texas fever tick, mange, or lice the vats may be provided with splashboards along the sides so as to turn the spray over the animals as they plunge into the dip and thus destroy a large percentage of the flies which are on them.

#### THE STABLE FLY.

(*Stomoxys calcitrans* L.)

The stable fly is probably even more widely distributed than the horn fly. It is known to occur in practically all parts of the world, and in the United States is found wherever domestic animals are kept. In importance it is scarcely second to the horn fly.

This insect (Pl. XXXIX, fig. 2) is also a relative of the house fly, and is often mistaken for that insect on account of the close resemblance. It is readily distinguished from the house fly, however, by its prominent piercing mouth parts. It is slightly larger than the house fly, and when on an animal usually remains with the head pointing upward. The horn fly, on the other hand, always alights with its head pointing downward, while the house fly may be seen in various positions.

The stable fly seldom becomes sufficiently numerous to cause serious annoyance until the middle or latter part of summer. After that its attack is continuous up to cold weather. All animals, including man, are attacked. As with the horn fly, the injury caused by this species is attributable to the irritation produced by its bite, which is extremely painful, and to the loss of blood, which is by no means inconsiderable when the pest is abundant. This insect has been shown to be the carrier of a species of round worm which infests cattle and it is also concerned in the transmission of a disease called surra, which is prevalent among live stock in certain tropical regions. In this country it is probable that it conveys anthrax from one animal to another. It has recently been shown that these flies may transmit infantile paralysis, and there is some reason to suspect them of being connected with the transmission of pellagra in man.

The most serious outbreak of this insect which has been observed in this country occurred during the latter part of the summer of 1912. The worst injury was experienced in the north-central part of Texas and in southern Oklahoma, although the pest was extremely abundant in parts of western Kansas and Nebraska. The flies appeared in myriads about the middle of August and attacked mules, horses, cattle, sheep, and hogs. They continued very numerous for about two months, during which time in a few counties in northern Texas fully 300 head of cattle, mules, and horses were killed by them. In many

cases the worryment induced the development of acute Texas fever in cattle which already carried the disease organism in their blood. Mules and horses were so annoyed that field work was largely prevented, and in many cases teams were caused to run away. All animals were greatly reduced in flesh, and the production of milch cows was reduced from 25 to 60 per cent, or even more.

The adult flies have been found to breed in several substances, including straw and manure of various kinds. The female deposits 200 to 300 elongate whitish eggs (Pl. XXXIX, fig. 1) on any of these substances which are found to be moist. These eggs hatch in from one to three days into minute maggots, which feed upon the decaying matter. When full-grown they transform to reddish-brown pupæ (Pl. XXXIX, fig. 3), from which the adult flies issue in about 22 days from the time the eggs are deposited. During the severe outbreak above described the flies were found to be breeding in great numbers in decaying straw stacks. The grain crop of 1912 was unusually heavy, producing a large number of straw stacks, which were thoroughly moistened by heavy August rains, thus forming numerous and attractive breeding places. When the flies are not very abundant their attack is confined largely to the lower parts of the legs of the animals (Pl. XXXIX, fig. 4), but when large numbers occur they feed on all parts of the host. Most of the flies leave the host as soon as they are filled with blood.

Repellent substances were found to be of little value in protecting horses and cattle. Mixtures of fish oil and tar seemed to be the most effective, but were not lasting. Work horses were much protected by placing burlap over their necks and backs and old trousers on their legs. When not at work the animals may be largely protected by placing them in dark or well-screened barns. The prevention of breeding is the most important step in the control of this species. Such straw as is desired for feeding animals should be stacked so as largely to keep out the rain, or, better, baled and stored under cover. Other straw should be burned or scattered over the fields and plowed under. The same procedure as is recommended for checking the breeding of the horn fly—that is, scattering the manure over the field every few days—is also advisable in combating this species.

#### THE SCREW WORM.

(*Chrysomyia macellaria* Fab.)

The screw worm is a common pest throughout the tropical and subtropical parts of North and South America. In this country it occurs as a pest as far north as Kansas and Tennessee and very rarely in Nebraska.

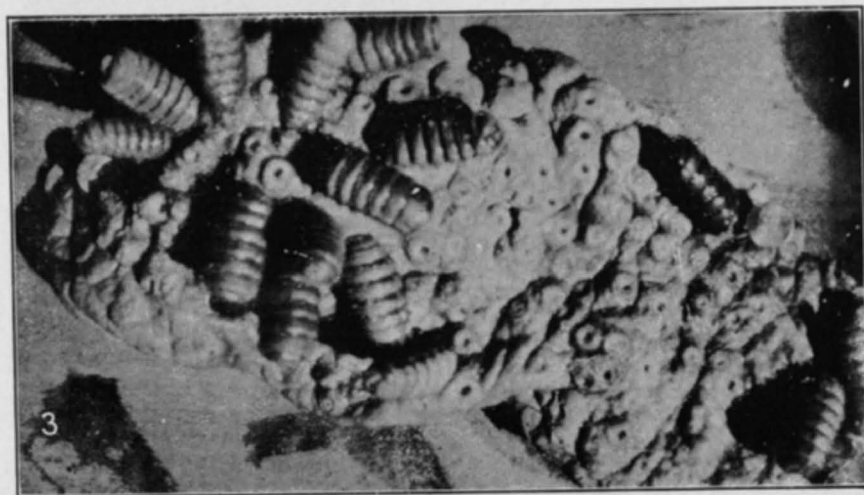

## INSECT ENEMIES OF LIVE STOCK IN THE UNITED STATES.

Fig. 1.—Horse bot (*Gastrophilus equi*): Eggs on hair on horse's leg. Fig. 2.—Same, adult female ( $\times 3\frac{1}{2}$ ). Fig. 3.—Same, portion of horse's stomach with bots attached and wounds produced by them. (Figs. 1 and 2, original; Fig. 3, after Osborn.)

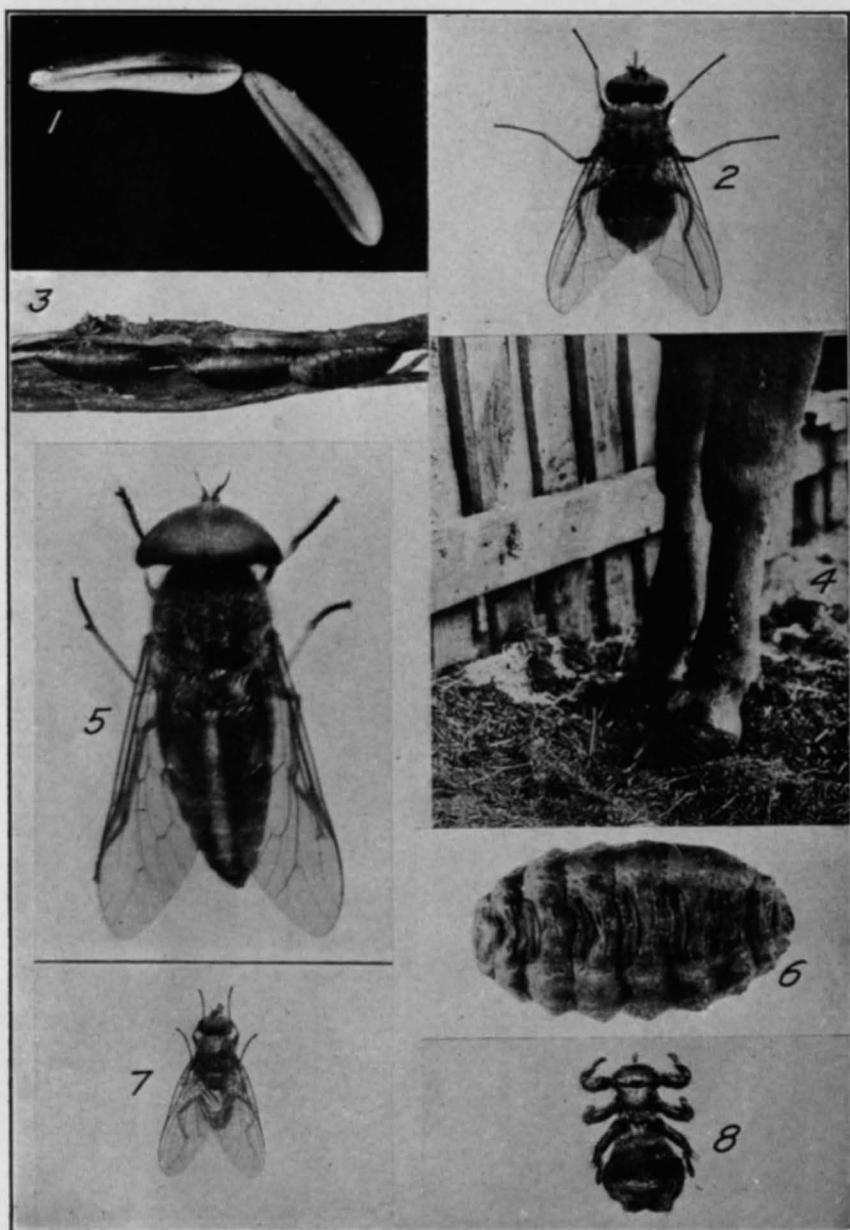

## INSECT ENEMIES OF LIVE STOCK IN THE UNITED STATES.

Fig. 1.—Stable fly (*Stomoxys calcitrans*): Eggs ( $\times 50$ ). Fig. 2.—Same, adult ( $\times 3\frac{1}{2}$ ). Fig. 3.—Same, puparia in straw ( $\times 3\frac{1}{2}$ ). Fig. 4.—Same, attacking legs of an ox. Fig. 5.—Green-head (*Tabanus lineola*): Adult ( $\times 3\frac{1}{2}$ ). Fig. 6.—Ox bot (*Hypoderma lineata*): Larva ( $\times 2$ ). Fig. 7.—Horn fly (*Lyperosia irritans*): Adult ( $\times 3\frac{1}{2}$ ). Fig. 8.—Sheep tick (*Melophagus ovinus*): Adult ( $\times 3\frac{1}{2}$ ). (Original.)

In certain parts of Texas this is by far the worst pest with which the cattle raiser has to deal. Cattle are probably the most subject to its attack, although horses, mules, sheep, goats, hogs, dogs, cats, and various wild animals are frequently infested. Man is far from exempt, as attested by the numerous references to this pest in medical literature. The injury in the case of this insect is produced entirely by the larvæ, which hatch from eggs deposited by adult flies on any sore or cut. The form of injury varies according to the character of the wound and place where it occurs. The larvæ burrow into the flesh and if not soon treated may permanently maim or even kill the host. The flies appear to be most numerous and cause the greatest injury in those parts of southern Texas where there is a dense growth of underbrush. In such sections many stockmen have been compelled to abandon the rearing of calves. In these localities yearlings are shipped in and no brood cattle are kept. The larvæ often penetrate the body at the navel, but in many cases they work through the tender hide on all parts of the calf and its death results in a very short time. Other common forms of injury are caused by the infestation of calves' mouths when teething, and the entrance of the larvæ into the teats and udders of cows suckling calves. As high as 99 per cent of newly castrated calves have been observed to be infested in certain parts of southern Texas. In some instances the larvæ gain entrance through the wound produced by branding or ear marking of calves. Mr. J. D. Mitchell states that he has seen cases where horses had lost one of their legs from the attack of these worms.

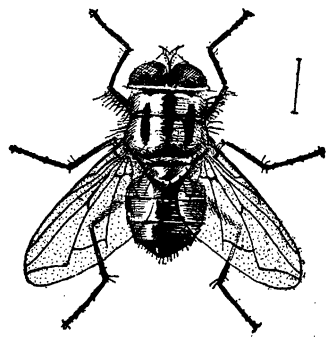

FIG. 14.—The screw-worm fly (*Chrysomya macellaria*): Adult. Enlarged. (From Howard.)

The flies are present in parts of Texas practically throughout the year, but the latter part of the summer and fall is the time when they become most injurious. The fly (fig. 14) is a bluish-green species with dark lines on the thorax. The eggs hatch very quickly, and the young maggots begin penetrating the flesh immediately. The maggots complete their growth in 5 or 6 days and then drop to the ground, burrow into it, and transform to the pupal stage. The flies emerge about 8 or 10 days later. The fly often lays its eggs in great numbers on dead animals and sometimes on moist decaying vegetable matter.

As with most insect pests, preventive measures are of much importance in controlling this insect. Since the larvæ often develop in

dead animals, it is essential that all carcasses should be burned or deeply buried after the death of the animal. Care should be taken to prevent animals becoming cut on barbed wire or allowing work horses to develop harness or saddle galls. The destruction of ticks by means of dips will greatly lessen the chances of infestation following the mashing of the engorged ticks on the host. In order to prevent the infestation of the scrotum of calves following castration it is advisable to treat them with tar or some other repellent substance. When infestation has already taken place the larvæ should be removed as thoroughly as possible and the remaining larvæ killed by putting chloroform into the wound. After the infestation has been killed out, the wound should be protected from the flies by a coating of tar or some other repellent substance. It has been found that some arsenical dips are very effective in destroying screw-worm larvæ in infested animals. In southern Texas Mr. J. D. Mitchell has observed cases where a large percentage of newly castrated calves which had become infested were dipped in an arsenical solution. The maggots were entirely destroyed, and no reinfestation took place.

#### THE BEDBUG AND THE MEXICAN CHICKEN BUG.

Among the true bugs the common bedbug (*Cimex lectularius* L.) and the Mexican chicken bug (*Hæmatosiphon inodora* Dugés) are the only two species which are of any considerable importance as animal pests, chickens being the principal hosts. Bedbugs and chicken bugs, being very closely related, are scarcely distinguishable. The former is found throughout the United States as well as practically all parts of the world, while the latter is restricted in its distribution and is found in the southwestern part of the United States and Mexico.

In chicken houses these two insects breed under similar conditions. They are usually to be found around the ends of the roosts and in the nests, though in case of heavy infestations the roof and walls are often infested. Both of these species are night feeders, and their presence is often overlooked. Through their attack egg production is reduced, and in some cases chickens become weak and die, owing to loss of blood. Brood hens are often driven from their nests, and thus successful hatching is interfered with. Where development in chicken houses is not checked they sometimes enter adjacent barns and become a source of annoyance to live stock.

In order to control these pests it is necessary thoroughly to renovate the chicken house, burning the straw in the nests, and removing unnecessary boards and boxes which offer them hiding places. All places where they are found to be breeding should be sprayed with kerosene or crude petroleum at frequent intervals.



## SUCKING LICE.

Nearly all animals are subject to attack of sucking lice. These small but often injurious little parasites spend their entire existence on their respective hosts. All of these insects are widely distributed, being spread throughout the country along with the animals which they infest.

Two species of sucking lice commonly attack cattle; one species is found upon the horse, and sheep, goats, and hogs are each attacked by distinct species. The two species which attack cattle are called the short-nose ox louse (*Hæmatopinus eurysternus* Nitzsch) and the long-nose ox louse (*H. vituli* L.). Both of these insects are small bluish creatures which are peculiarly adapted to living on animals, being provided with claws and spines with which they cling to the hair.

It is well known among stockmen that where these pests become numerous cattle get poor and are more likely to succumb during hard winters, though the pests are not likely to produce death if animals are properly cared for. With the thousands of specimens on animals the loss of blood must be considerable. This, together with the irritation, affects the condition of the animal as well as the milk supply.

The louse (*Hæmatopinus asini* L.), which commonly infests horses, also attacks donkeys and mules. Where horses are well fed and carefully groomed this insect is of little or no importance, but on range stock it is sufficiently numerous greatly to reduce their condition.

The hog louse (*Hæmatopinus urius* Nitzsch) is one of the largest and most common lice met with in this country. Although it occurs in practically all parts of the United States, it often becomes sufficiently numerous greatly to stunt the growth of hogs, especially those which are allowed to run free without special care. Like all of the other members of this group, the eggs of this species are laid on the hair of the host, where they remain firmly attached even after the young lice have escaped from them.

The members of this group of insects are easily destroyed by applications of insecticides to the host animal. Comparatively weak solutions of any of the standard sheep dips, the tobacco and sulphur dip used against the scab mites, and the arsenical solutions used against ticks, are all effective in killing the lice. The eggs, however, are more resistant, and it is advisable to dip or spray the infested animals a second time after an interval of 10 days or 2 weeks. Where only a few of the stock are infested the greasing of the animal with a mixture of kerosene, lard, and sulphur is sufficient.

## BITING LICE.

Nearly all animals, including the very small mammals and birds, are infested with one or more species of the curious, flattened para-

sites known as biting lice. These insects may be distinguished from the sucking lice by the broad, rounded head and biting mouth parts.

Like the sucking lice, the entire development of these insects is passed on the host. Chickens suffer more from the attacks of these insects than any other domesticated species. Although the biting lice of chickens are widely distributed in this country, they become of much greater importance as pests in the Southern States, where it is not uncommon for full-grown fowls to be greatly reduced in flesh and even killed by their attack, while the young birds are even more susceptible.

The best method of keeping the flock clean is to start with incubator chickens only and not allow the young and old chickens to be associated. When lice are present, an application of kerosene and lard or carbolated vaseline is sufficient to destroy them. Brooding hens should be thoroughly dusted with pyrethrum shortly before the eggs are expected to hatch.

Among the larger domestic animals, goats, sheep, horses, asses, mules, and cattle are each subject to the attack of biting lice. The same remedies used against sucking lice are effective in the control of these pests.

Among the other insects which affect live stock the fleas (particularly the chicken flea), the sheep tick (Pl. XXXIX, fig. 8), horse tick or forest fly, and mosquitoes are of considerable importance. These insects, as well as the other species discussed, are treated in some detail in Bulletin 5 of the Bureau of Entomology and will receive special treatment in future publications.

## RELATION OF BIRDS TO GRAIN APHIDES.

By W. L. MCATEE,

*Assistant Biologist, Biological Survey.*

### INTRODUCTION.

Several species of aphides or plant lice habitually feed on growing cereal crops. None of them ever attracted much attention in the United States, however, until the first serious outbreak, in 1890, of an imported species (*Toxoptera graminum*) now commonly known as the "green bug." Widespread and disastrous irruptions of the green bug occurred also in 1901, 1903, and 1907. In the last-named year the wheat and oat crops of Kansas, Oklahoma, and Texas fell about 50,000,000 bushels short of the average.<sup>1</sup>

In 1909 grain aphides were excessively abundant and injurious in parts of North Carolina. One badly infested locality near Winston-Salem was visited by the writer for the purpose of learning the relations of birds to the pests. Here the birds in the grainfields were studied daily from March 29 to April 4, and more than 150 stomachs, representing 13 species, were collected for detailed examination. Most of the investigation was made on the farm of Mr. G. W. Hinshaw, to whom acknowledgment of many courtesies is due.

### DESCRIPTION OF THE OUTBREAK.

The writer's visit immediately followed a period of hard driving rain, during which the number of aphides was very materially reduced. Some rye plants that had been sheltered by a tobacco barn in course of construction were pointed out as typical of conditions before the rain. These plants bore from 60 to 75 aphides each. Unsheltered plants, however, as was learned by test counts in various parts of the 100 acres of young wheat and rye on the farm, bore on the average not more than one aphid each. An oat field some miles away, which probably was not reached by the heavy rains, was very densely populated with aphides, and as the result of their attacks most of the plants had turned reddish or brown.

---

<sup>1</sup>Bul. 110, U. S. Bur. Entomology, p. 40, 1912.

## APHIDES PARTICIPATING IN THE OUTBREAK.

While the green bug was well represented on the grain plants, it was not the most abundant species. That rank was taken by another common and widely distributed species (*Macrosiphum granaria*). Still another aphid (*Siphocoryne avenae*), often referred to as the European grain louse, was present. While these two species undoubtedly are injurious to growing grain and sometimes destroy parts of fields where they become extremely abundant, it seems well established that their power of destruction is greatly inferior to that of the green bug (*Toxoptera*). Whether the latter has a toxic effect upon the plants or whether its greater harmfulness is due to some other cause, observations and the experiments thus far performed show that *Toxoptera*, although smaller than *Macrosiphum*, is much more destructive to the host plants.<sup>1</sup>

## EXAMINATION OF BIRD STOMACHS.

The discrepancy in economic importance of the aphides concerned in the infestation made it desirable to learn, if possible, the exact numbers of *Toxoptera* eaten by the birds. Much time was spent in seeking a practicable method of distinguishing the three genera of aphides in the condition in which they were found in the bird stomachs. The attempt was unsuccessful, however, and consultations with specialists revealed the fact that they could not separate all, or even the good specimens, without an entirely disproportionate expenditure of time and effort. Nor is this surprising when we reflect that any of the stomachs might contain a mixture of all stages, from the smallest young to the perfect adults of all three genera. Moreover, plant lice are so extremely fragile that the greater number in almost every stomach were ground up beyond specific recognition. We were forced, therefore, to be content with a simple enumeration of the specimens and the knowledge that probably all of them belonged to one or another of the genera of grain aphides. However, among the adult specimens in more perfect condition all three of the species mentioned above were definitely identified.

While it is unfortunate that we are unable to state in exact terms the relation of birds to the more injurious *Toxoptera*, we run no risk of mistake as to the economic value of the birds, because all of the aphides are injurious, and birds preying upon them must be given credit for good work.

---

<sup>1</sup> Bul. Univ. Kans., Vol. IX, No. 2, p. 98, 1909.

## RECORD OF THE BIRDS BY SPECIES.

The stomachs of three species of birds that contained food yielded no aphides. These species are the chickadee and pine warbler, which, from their arboreal habits, would hardly be expected to feed on grain aphides, and the robin, a bird rather above the size for aphis-eating.

It should be borne in mind throughout that complete enumeration of the plant lice was possible in very few cases. In the majority of instances the finely ground remains of aphides probably represented as many, if not more, individuals than we were able to count among the better preserved material.

**GOLDFINCH** (*Astragalinus tristis*).—Of all the species of which a considerable number of stomachs were collected, the goldfinches (fig. 15) made the best use of their opportunities for aphis-eating. Aphides were found in all but 5 stomachs out of a total of 25 collected. No fewer than 325 plant lice were counted in the contents of one stomach, and the average number of countable aphides in the 20 stomachs was 132.5. They constituted, on the average, 82.75 per cent of the total food. This is a splendid record for this charming little bird, which is popularly known as the wild canary, thistle bird, or lettuce bird. A flock of goldfinches frequented the vicinity of a telephone line running through the farm, and from their perches on the wires the birds were continually flying down among the rye for aphides.

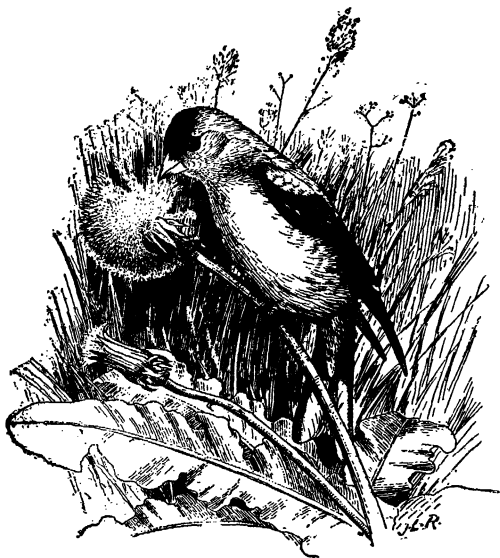

FIG. 15.—Goldfinch.

**PINE SISKIN** (*Spinus pinus*).—Only one pine siskin was collected. It had eaten more than 80 aphides, which composed practically the entire stomach contents.

**VESPER SPARROW** (*Poocetes gramineus*).—This was the most abundant species of regular occurrence on the farm. Twenty-two stomachs were collected, 15 of which contained plant lice. The average percentage of the food composed of aphides was 19.5, and the largest number counted in any stomach was 42. Manifestly the vesper

sparrow was not so fond of plant lice as most of the other sparrows. It ate about as large a proportion of beetles as of aphides.

**SAVANNA SPARROW** (*Passercubus sandwichensis savanna*).—Thirteen out of 20 savanna sparrows collected had eaten aphides. The largest number secured by any one bird was 130 and the average number 63.5. Aphides composed an average of 25.3 per cent of the stomach contents of birds of this species.

number 63.5. Aphides composed an average of 25.3 per cent of the stomach contents of birds of this species.

**CHIPPING SPARROW** (*Spizella passerina*). — The familiar “chippy” (fig. 16) was common and proved to be a good aphid-consumer. Thirty-five birds out of 48 collected had eaten plant lice. The largest number taken by any individual was 260; the average number 94.76. A little more than 45 per cent of the total food of these birds consisted of grain aphides.

**FIELD SPARROW** (*Spizella pusilla*).—Only 6 field sparrows were collected. Three of them had eaten plant lice to the average extent of 96 per cent of

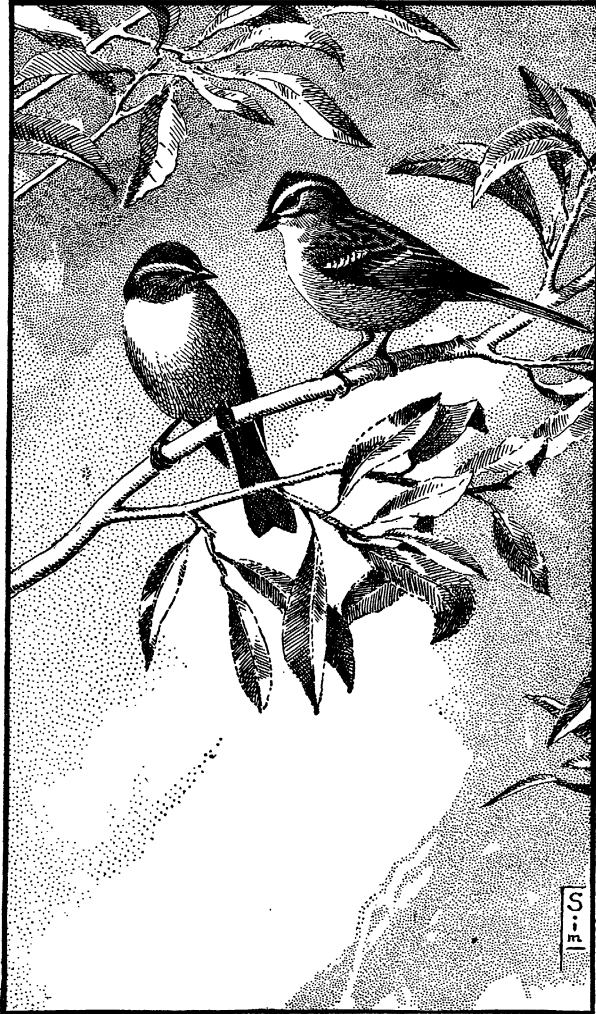

FIG. 16.—Chipping sparrow.

their food. The numbers of aphides that could be counted in their stomach contents were 87, 180, and 196, an average of 154. This is a praiseworthy showing, and it would be interesting to know whether it would have been maintained had a larger number of specimens been examined.

**SNOWBIRD** (*Junco hyemalis*).—Only 7 snowbird stomachs out of a total of 17 contained aphides. The plant lice could be counted in only one instance, 14 being distinguished. The average percentage of the food composed of aphides was only 5.2, quite the lowest record of any of the aphis-eating birds.

**SONG SPARROW** (*Melospiza melodia*).—Two song sparrows (fig. 17) were collected, of which one had eaten about 50 plant lice, which composed 80 per cent of its food.

**TITLARK** (*Anthus rubescens*).—A very large flock of titlarks visited the farm one day during the investigation. Only one could be collected, but it had eaten 100 or more aphides, which constituted about 70 per cent of its food.

NUMBER OF APHIS-EATING BIRDS ON THE FARM.

While working over the Winston-Salem farm the writer endeavored to take a fairly accurate census of the bird-population, including, however, only those birds spending

most of the time among the aphis-infested grain. The results are as follows: Goldfinch, 300 individuals; vesper sparrow, 2,590; savanna sparrow, 70; chipping sparrow, 245; field sparrow, 20; snowbird, 70; and song sparrow, 6.

The number of song sparrows, and probably also of field sparrows, is not above the normal for the nesting season, and hence is at the minimum for the year. All of the others were far more abundant than they would be in the breeding season; in fact, two species, the vesper sparrow and snowbird, do not breed in the vicinity of Winston-Salem. The period of observation was in the height of the migration of such species as the chipping, vesper, and savanna sparrows. The activity of migration at the time is further evidenced by the occurrence on one day each of a flock of 100 pine siskins and one of about 5,000 titlarks.

NUMBER OF APHIDES EATEN BY THE BIRDS.

In estimating the quantity of food consumed by birds feeding on a mixed diet of average digestibility we usually regard the day's



FIG. 17.—Song sparrow.

subsistence as about five or six times the average amount found in the stomachs. It is evident that we can not compute the consumption of plant lice by the same formula, as these minute, soft-bodied insects are so delicate that they are digested in a small fraction of the time required for hard insects and seeds. To get a proper idea of the number of meals of plant lice taken in a day we must consult the actual records of some of the Winston-Salem birds. In most cases it is evident that the birds ate about as many aphides at one time of day as another. This is well illustrated by the records of the goldfinch and the chipping sparrow, as follows:

*Record of aphides eaten by the goldfinch and the chipping sparrow.*

Goldfinch.				Chipping sparrow.			
Hour.	Number of stomachs. <sup>1</sup>	Average per cent of aphides.	Average number of aphides.	Hour.	Number of stomachs. <sup>2</sup>	Average per cent of aphides.	Average number of aphides.
10	10	88.8	120.9	10	1	32.0	100.0
11	.....	.....	.....	11	6	59.3	114.1
12	1	100.0	150.0	12	3	43.0	73.3
1	.....	.....	.....	1	2	60.0	52.5
2	2	48.0	97.0	2	.....	.....	.....
3	2	84.0	137.5	3	4	48.0	97.7
4	3	91.0	185.6	4	1	42.0	9.0
5	.....	.....	.....	5	1	54.0	85.0

<sup>1</sup> 2 stomachs in which aphides were not counted.

<sup>2</sup> 15 stomachs in which aphides were not counted.

In the case of the chipping sparrow we have specimens representing more hours of the day than for any other species. The record shows that at all hours from 10 a. m. to 5 p. m., excepting one unrepresented and one showing only a few aphides eaten, chipping sparrow stomachs contained large numbers of plant lice in good enough condition for counting. The fact that they were not far digested proves that they were recently swallowed, certainly within an hour.

We are justified, therefore, in considering that at least one meal of plant lice is taken each hour; probably several are. At the time of year the stomachs were collected, birds, if they so desired, could feed during a period of about 14 hours per day. We are distinctly on the safe side, therefore, in reckoning one meal of aphides to each of 10 hours in the day. If, therefore, we multiply by 10 the average number of aphides eaten per meal by the birds of any species, we shall arrive at the daily consumption per individual. We are further justified in regarding the proportion of aphid-eating birds to be



the same for all the individuals of a species on the farm as among the individuals whose stomachs were examined. Hence the daily consumption of plant lice per individual, multiplied by the proper proportion of the birds of each species, will give the total daily destruction of aphides per species. As the number of aphides that can be counted is in nearly every case far under the number actually represented in the stomach, and as we reckon 10 meals when probably more than 14 are taken, it must be admitted that our estimates are conservative.

*Estimated number of aphides eaten daily by birds.*

Bird.	Number present.	Number eating aphides.	Average number of aphides eaten.	Total number of aphides eaten per day.
Goldfinch.....	300	240	132.5	318,000
Vesper sparrow.....	2,590	1,761	22.5	396,225
Savanna sparrow.....	70	45	63.5	28,570
Chipping sparrow.....	245	178	94.7	168,560
Field sparrow.....	20	10	154.3	15,430
Snowbird.....	70	28	14.0	3,920
Song sparrow.....	6	3	50.0	1,500
Grand total.....				932,205

In addition to the aphides destroyed by the birds present throughout the investigation, we must reckon those taken by the transient flocks of siskins and titlarks. To be on the safe side we will assume that during their brief visits these birds consumed only half as many meals per day as the other species. It will be more accurate also to use the averages of the other species as to the number of birds eating plant lice (61 per cent) and the number of aphides consumed (75.9 per cent) rather than the higher records for each of those birds which are based upon single stomach examinations. Upon this basis their records are as follows:

*Estimated number of aphides eaten by the pine siskin and the titlark.*

Bird.	Number present.	Number eating aphides.	Average number of aphides eaten.	Total number of aphides eaten.
Pine siskin.....	100	61	75.9	23,145
Titlark.....	5,000	3,050	75.9	1,157,475
Grand total.....				1,180,620

## SUMMARY.

The birds frequenting about 100 acres of grainfields near Winston-Salem, N. C., from March 29 to April 4, 1909, certainly destroyed about 1,000,000 grain aphides daily. These birds are all members of the sparrow family and are not usually given much credit as destroyers of insects.

A flock of about 5,000 titlarks spent part of one day on the farm, and it is probable that in that time they ate more than a million grain aphides.

It must be admitted that these numbers, representative of migration time, are far above the possibilities of the normal bird population of the farm. It is true, on the other hand, that nearly all of the sparrows had been abundant on the farm and carrying on their good work since very early spring. What is more important, this is the season of the year when the aphides are freest from other natural checks, and the repressive influence of the birds therefore has its maximum value. The grain aphides can reproduce at a temperature about 16° F. below that which will permit the increase of their most important parasite. This means that in the vicinity of Winston-Salem the plant lice can breed unmolested for about a month in spring, probably from about the 10th or 15th of February to a corresponding date in March.

Sparrows are abundant throughout this period and their destruction of 10,000 aphides per acre per day, the rate ascertained in 1909, reduced by an incalculable number the aphid infestation in the grain-growing region of North Carolina. All of the birds found preying upon the aphides at Winston-Salem are common in winter throughout the Southern States, in all of which they no doubt render equally important service to grain crops.

## NATIONAL FOREST TIMBER FOR THE SMALL OPERATOR.

By WILLIAM B. GREELEY,  
*In Charge of Silviculture, Forest Service.*

### USERS OF NATIONAL FOREST TIMBER.

Three thousand small logging operators and users of timber are now supplied with their raw material by the National Forests, through purchase from the United States; 25,000 more obtain timber for their own needs without charge. The small operator is the industrial agent sought by the Forest Service to manufacture the timber on the National Forests and distribute it to the consumers. At the same time the utilization of the Forests requires many large operators. Numerous bodies of timber can not be developed without large investments of capital or logged without a business organization and equipment of corresponding scale. The physical conditions on the National Forests afford opportunity for business enterprises of every size, from the shake maker, equipped with a wagon and half a dozen tools, who buys, fells, and rives a single tree, to the large lumber company, which must construct and operate a two-band sawmill and 50 or 60 miles of logging railroad for the development of a large body of timber, which without this equipment would be wholly inaccessible. Good administration of the National Forests requires the encouragement of all classes of operators—the small logger or millman, wherever he is able to put the stumpage of the Government upon the market in the form of commercial products; the larger lumberman, where the resources of the Forests can not be put to use without his business organization and capital.

### HOW THE PRINCIPLE WORKS.

The sales on the Deerlodge National Forest, of central Montana, show how this principle actually works. This Forest supplies 119 timber operators, one of which is a large company, logging in the higher valleys near the Continental Divide, where extensive investments are required for flumes, roads, and other equipment beyond the means of the individual operator. The rest are small loggers, cutting

in the lower, more accessible regions, where the timber can be marketed by short flumes or hauled out by wagon or sled. The combined annual output is 16,000,000 feet of scale timber, 6,000 cords of fuel wood, and 336,000 pieces of mine props, poles, and lagging, practically all of which is used in the great copper mines of Butte.

#### PROPORTION OF SMALL OPERATIONS.

Small operators handle the bulk of timber cut from the National Forests; 99 per cent of the 5,772 sales made last year were for amounts under \$5,000 in value, and 97 per cent were for amounts under \$1,000. Operators of this class cut, all told, 273,935,000 board feet, or 63 per cent of the total amount removed from the Forests under sales during the year. While the large operator must be encouraged to exploit the less accessible areas where costly improvements are necessary, the small logger and millman will continue to be the chief customer of the public in the disposal of its timber.

#### OPPORTUNITIES FOR THE SMALL OPERATOR.

The National Forests afford opportunities of two broad classes to the small timber operator. He may either supply some local market which is more or less isolated from the competitive lumber trade, or he may cut and sell timber for wider consumption where the kind of products or the logging conditions of the locality may make him a successful competitor of the large lumberman, or give him a distinct place in the industry in cooperation with large operators or manufacturers. The first, cutting for near-by industries or communities, is distinctly and almost exclusively a field for the small operator. Such purchasers now cut annually 213,000,000 board feet for local supply. For the lumberman of limited capital this is the best chance offered. Not only do local market and industrial conditions favor the small operator in this field, but the future of his business, in so far as the available supply of timber is concerned, is directly protected by the National Forests. A permanent supply of timber ample for all local needs, and hence for a permanent local industry engaged in its logging and manufacture, is the first concern of the Forest Service. It is worth while to show how this supply is maintained.

#### LOCAL USES PROVIDED FOR.

The timber resources of the National Forests, aggregating 600,000,000,000 feet of merchantable material, besides large areas of young growth not yet of commercial size, are administered by natural units determined by topography, markets, and transportation facilities. The amount of wood produced annually on each unit by the growth

of the trees determines the amount which can be cut. More than this can not be removed without depleting the supply. Out of this annual cut, which can be maintained for all time, provision is made first for the needs of the locality and for the industries of all kinds which are in or near the Forests and which depend upon them for a supply of timber. No sales for outside markets are made unless it is clear that the Forest is growing more timber than the localities surrounding it can use, both now and under any anticipated future development. On a number of Forests like the Sioux in South Dakota, the Modoc in California, the Madison in Montana, and the Pocatello group in southern Idaho local uses require the entire output of the National Forests. Sales for shipment into the general lumber markets of the country are not permitted. Elsewhere, as in heavily forested regions of northern Idaho, the west slope of the Cascades in Oregon and Washington, and the Sierras in California, the production of timber on the public Forests is far in excess of the amount required by adjacent regions. Here sales for the general lumber trade of the country form the only means of utilizing the ripening timber which must be cut.

Under present conditions, half a billion feet of National Forest timber is reserved for the aggregate yearly supply of near-by industries and communities. For this supply local operators have first claim. The permanency of their industry is assured, as far as it is possible for the Government to do so, and is limited only by the permanency of the markets which they supply. These markets are scattered over a wide area and form innumerable little units or local centers of demand. The demand may come from a mine, a railroad seeking ties near at hand, a salmon-packing factory on the Alaskan coast, a community of settlers, an agricultural valley which has outgrown its pioneer days and is demanding more and better buildings, an irrigation project, a new hydroelectric power plant, a town wood yard or lumber yard, or a fruit district needing trays and boxes. Nine small sawmills in the valleys tributary to the Madison River at the head of the Missouri drainage in Montana are supplied from the Madison National Forest. Their cut is divided between grain and stock growers and local mines. Yet 23 other operators are busy for considerable portions of the year on this Forest, in taking out house logs, fence posts, cordwood, and other material in the round. Five small sawmills are maintained by the Helena National Forest, in the same State, cutting for farms and mines. Last year they sawed 387,000 board feet of lumber. The annual product of this Forest, which supplies 68 local operators, includes 1,400 cords of fuel for the city of Helena and 532 cords for ranches and mines, 105,000 board feet of mining stulls, 46,500 pieces of mine lagging, and 2,000 fence posts and poles.

## EXAMPLES OF LOCAL USE.

The Modoc National Forest, in northeastern California, furnishes the supply for 54 local timber operators. Their output last year totaled 1,086,000 feet of lumber, 336,000 cords of fuel, and 29,658 fence posts, besides small quantities of poles, shingles, and shakes, or long shingles rived by hand. These operators supply three-fourths of the local demand of the entire country adjacent to the National Forest, an area of 4,100 square miles, with a population of 6,000 people. They furnish 784 farms with building and fence material and fuel, and a number of local mines with the timber needed.

The varied industries in the foothills adjoining the Tahoe National Forest in California maintain 18 operators in Forest timber, cutting lumber, fuel, cedar fence posts and poles, mine lagging, shakes, and hydraulic blocks for use in placer mining. The Pike National Forest, near Denver, located in a region of many varied industries and demands for forest products, has 99 small operators, who cut each year nearly 5,000,000 board feet of lumber, railroad ties, mine props, and poles.

Many Forests are identified through their local operators with industries peculiar to the regions in which they are located. Small mills on the Sierra, in central California, cut yearly some 800,000 board feet of trays for the Fresno raisin district. Practically the entire cut on the Toiyabe, employing 50 contractors and aggregating 1,275,000 board feet annually, goes to supply the mining industry of central Nevada. Four small mills on the Trinity National Forest in northwestern California are operated by mining companies, solely for the production of boards and timbers required in their mines. The Alaskan Forests now produce nearly 43,000,000 board feet a year, cut by over 100 loggers and mills, which partly supplies the salmon-packing industry, and furnishes the piling required in constructing wharves and landings, and props for a number of mines, as well as the needs of many settlers and communities for building material and fuel. The principal product of the Bear-tooth National Forest is round props used in mining the coal measures of the Red Lodge district, Montana. Over 100,000 of these props are now cut annually from this unit by a dozen different loggers.

Small operators cut annually over 300,000 railroad ties from the National Forests of Colorado and Wyoming, which form the logical supply for the railroads traversing those States, and over 120,000 from the Forests in Montana.

Rarely, as in the case of the copper mines at Butte, are large timber-operations required for the supply of local industries or com-



A "FARMERS' SAW MILL" ON THE WEISER NATIONAL FOREST, IDAHO, OPERATED BY RANCHERS DURING SLACK PERIODS ON THEIR FARMS.



FIG. 1.—A SMALL MILL ON THE BOISE NATIONAL FOREST, IDAHO, THE PRODUCT OF WHICH IS USED CHIEFLY FOR PLACER MINING.



FIG. 2.—A SMALL MOUNTAIN SAW MILL WHICH SUPPLIES LOCAL SETTLERS ON HOLY CROSS NATIONAL FOREST, COLORADO.





FIG. 1.—TAKING OUT MINING TIMBERS FROM THE BEARTOOTH NATIONAL FOREST, MONTANA.



FIG. 2.—A SMALL NATIONAL FOREST SAW MILL IN COLORADO WHICH CUTS LUMBER, SHINGLES, AND RAILROAD TIES FOR LOCAL USE.

munities. In these markets, often isolated from the general channels of supply and directly accessible to National Forest areas, the small millman or logger is strongly entrenched. This local lumbering industry, maintained and protected by the National Forests, should expand steadily with the advancing settlement and industrial development of the West.

#### OTHER OPPORTUNITIES FOR THE SMALL OPERATOR.

The second class of opportunities for the small operator is in cutting Forest products for the general trade. The competitive markets are controlled mainly by the large sawmill because it manufactures cheaper and usually better lumber than the small plant. There is, however, a place for the small operator in the general lumbering industry of the West, as well as in lumbering for local uses. Small mills and logging outfits now cut 60,000,000 board feet annually from the Forests for the outside trade. The mountain areas within the Forests contain many small basins or gulches of timber cut off from other bodies by rugged topography. Such units do not warrant the investment or organization of a large operation. They can be exploited only by small mills with inexpensive equipment cutting a few hundred thousand feet annually and hauling their product by wagon to the nearest railroad or market. Many little logging units of this nature have been tapped by wagon roads, and now support small mills, cutting chiefly for local supply, but to some extent also for the general trade. A vastly greater number are still to be developed. These await the small operator.

In other regions, particularly those traversed by drivable streams, the small operator finds his logical place in the industry as a logger, buying stumpage from the Government, hauling the timber to water, and selling his logs at the river or mill pond to the manufacturer. But little capital is required for such operations, which can be conducted on almost any scale from a few thousand board feet to 5,000,000 or 10,000,000 annually. Ten million feet are cut yearly from the Kootenai National Forest in northwestern Montana in operations ranging from 2,000,000 feet down, and sold on the bank of the Kootenai River to a large downstream mill. Many other small loggers are buying National Forest stumpage tributary to the Coeur d'Alene and St. Joe Rivers in Idaho and driving their logs down those streams for sale to mills on Coeur d'Alene Lake. Priest River, draining the Kaniksu Forest in northern Idaho and forming a ready channel to the mills on the Pend Oreille River, is another logging nucleus where a considerable part of the cut is handled by small jobbers.

## SPECIAL FOREST PRODUCTS.

Still other opportunities are afforded in cutting and marketing special forest products which require no great investment and can be handled advantageously in small quantities. Railroad ties, hewed by hand, are cut in small sales on at least 30 National Forests. Some 25 or 30 small operators are employed on the National Forests of western Montana and northern Idaho in cutting red-cedar telephone and telegraph poles, fence posts, and shingle bolts, and many more in the Cascade Forests of western Washington and Oregon. The National Forests of Arkansas support 35 small operators who cut all told nearly 6,000,000 feet of timber annually for outside consumption. This cut is distributed over an interesting variety of products, including shortleaf-pine lumber, hardwood lumber, oak wagon stock, and white-oak barrel staves and heading. The cutting of high-grade oak cooperage is the most distinctive industry on this Forest. A number of portable mills are operated by small manufacturers who cut rough-sawed staves, haul them to the railroad, and sell to finishing mills or middlemen. Still other small operators or settlers within the Forest buy small quantities of white oak and employ their slack time in riving staves by hand. These are sent in the rough to finishing mills. Further illustrations are unnecessary to indicate the varied opportunities for small timber operators in the National Forests.

## OPPORTUNITIES FOR EASTERN OPERATORS.

Many unused locations are available for eastern operators whose supply of timber is now cut out, men who have small amounts of capital backed by experience in woods or mill work. Under the policy followed in the administration of the National Forests, these locations have a guaranteed future supply of timber such as has never existed in any of the old lumbering centers of the United States. Sites are available for small sawmills, of the single circular saw and edger type, cutting from 5,000 to 10,000 board feet per day. Four or five teams are required for logging and hauling lumber, trucks or sleds for woods work, and wagons for the lumber haul. Such enterprises are practicable with an investment of from \$10,000 to \$15,000, allowing a reasonable working margin over the cost of equipment. The average mill of this type, running 200 days in the year, turns out a million feet of lumber in the year's operation. Under ordinary conditions the operator should secure a profit of \$2.50 or \$3 per thousand board feet, which insures a fair return on the investment and on the time and effort given to the enterprise.

## HAND-WORKED TIMBERS.

Other opportunities requiring less capital are offered in logging and selling timber in the round or logging combined with ax work, as in the production of timbers hewed or rived by hand. There is a wide range in the character of such enterprises and in the amount of money required to conduct them. At one extreme is the cordwood operator or producer of mine lagging or props, who requires only a wagon and team besides his ax and crosscut saw. Buying small bodies of National Forest timber and building their own roads into the areas purchased, many men are now making an independent livelihood by woods work on even this limited scale. The cutting of hewed crossties affords many opportunities for similar enterprises of somewhat larger scope. With a capital of \$5,000, sufficient to secure five or six teams with sleds or trucks and woods tools and to provide a working margin for carrying the current bills, it is practicable under average conditions to handle from 3,000 to 5,000 ties per month at a profit of about 5 cents per tie. A little larger investment, from \$6,000 to \$7,000, on account of the greater margin necessary to cover current expenses, would be sufficient for a logging operation in saw timber or cedar poles. With five teams and the necessary equipment of chains and tongs, sleds, etc., from 500,000 to 800,000 feet of logs can be handled under ordinary conditions in a winter's operation, and their sale at the nearest drivable stream or road should net the operator a profit of \$2 per thousand feet. Such operations can be increased in scale practically without limit, with a corresponding increase in the capital and equipment necessary.

## SMALL INVESTMENT REQUIRED.

An important factor in all of these operations is that scarcely any preliminary investment in stumpage is required. The timber is paid for in small installments, from \$50 to \$300, each in accordance with the amount purchased, in advance of cutting. The operator buying \$1,000 worth of stumpage to be cut in 5 months is required to deposit \$200 or \$250 at the outset, making a second deposit of the same amount when timber to the value of the first has been cut, and so on to the end of the sale. The purchaser is thus relieved both from the initial investment which must be made whenever privately owned timber is purchased and from the carrying charges on such investments in the form of interest and taxes. This is of special importance to the operator of limited capital, who must restrict his investment as far as possible and turn it over as often as he can.

## BENEFITS ACCRUING TO FARMERS AND SETTLERS.

Aside from the opportunities for loggers and millmen who make their livelihood by timber operations, the farmers and settlers in the vicinity of the Forests are greatly benefited by the sale policy pursued by the Forest Service. This is an important factor in the desirability of farms and homesteads in or near the National Forests.

The free use of Forest timber for ordinary farm improvements and fuel is provided to settlers and others who need this assistance. At least 125,000,000 feet are now cut annually from the National Forests by settlers, prospectors, and other local residents without charge for their own use. Timber for farm uses and improvements not provided under the free-use regulations may be purchased from the Forests at the actual cost of administering the sale. Farmers in the vicinity of the National Forests are thus guaranteed all of the timber which will be required in the improvement of their land or for personal use, either wholly without charge or at a purely nominal price. A large number of small mills in the Forests are owned and operated by farmers who utilize their slack time on the farm for logging or milling either for their own needs or for sale. (See Pl. XL.) An excellent illustration of such use of the Forests and of the cooperation of farmers in procuring the timber needed for their homesteads is found on the Manti Forest in Utah. The territory surrounding this Forest is well settled, the principal livelihood of the people being agriculture. The average land ownership of the region is about 36 acres. Such small holdings make it necessary for the ranchers to do their own timberwork as far as possible in order to reduce the cost of farm improvements. These men, as a rule, own their own teams and wagons and the other equipment necessary for logging under simple methods. Many of them cut independently from the Forest the material required on their ranches; others cooperate in running small sawmills in seasons of the year when farm work is slack. A permanent supply of timber for the needs of such localities is always reserved by the Forest Service on the areas which are most accessible to the ranches to be supplied.

## WINTER EMPLOYMENT FOR FARMERS AND TEAMS.

Aside from securing material needed for ranch improvements, many farmers in National Forest regions find winter employment for themselves and their teams during the months when there is little or nothing to do on the farm in cutting logs, railroad ties, poles, and other products for sale. In heavily timbered regions where large mills are established, as on the National Forests in western Montana and northern Idaho, many ranchers find profitable

winter employment as logging jobbers or contractors. In other districts, as on the Deerlodge and Helena Forests, in central Montana, winter employment for ranchers and their teams is furnished in cutting and hauling cordwood for city yards, lagging and mine timbers for the copper and coal mines, converter poles for the smelters, and round house logs and other timbers for sale to their neighbors. The additional employment thus furnished through the National Forests is often of great assistance to homesteaders during the first hard years of developing their claims. Hundreds of western ranchers have found a profitable and practicable combination in farming during portions of the year and cutting timber under small sales on the National Forests during other portions. (See Pls. XLI and XLII.)

#### PURPOSE OF THE NATIONAL FOREST REGULATIONS.

The timber on the National Forests is put to use. It is not locked up. The aim of the Forest regulations is to permit such use with the greatest simplicity and dispatch consistent with regard for the public interests involved and with the least possible formality, "red tape," or inconvenience to the user. Sales under \$100 in amount are made directly by the local rangers and supervisors on the Forests at the verbal or written request of the purchaser. According to law, sales for larger amounts must be advertised for 30 days in advance of sale. A minimum price is agreed upon with the applicant and published as the "upset" (lowest) price which the Government will accept. Bids are then submitted by the applicant and any others who may desire to bid. The timber is awarded to the highest bidder unless this would result in monopoly, as in cases where an independent operator owning no timber is outbid by an established lumber company with extensive holdings. Following the award of the timber a very simple contract is prepared, which states the price, the period within which the timber is to be removed, and the other conditions with which the purchaser must comply. As soon as this contract is executed cutting may begin.

#### HOW PRICES ARE FIXED.

In determining the upset price placed upon National Forest timber it is the purpose of the Government to arrive at the actual market value of the standing stumpage, considering its quality, its accessibility, the cost of logging and manufacture, and the market value of the final products. A careful estimate of all of these factors is made, including a profit to the purchaser of from 15 to 25 per cent of the amount invested in each thousand feet of timber in the process of taking it from the stump to the railroad or market. In sales to

small mills or loggers the price is based upon the methods of logging and manufacture which are practicable for the type of operation concerned. It is realized that a millman or logger who cuts but small quantities is often required unavoidably to use more costly and less efficient methods than a large, well-equipped plant which operates on a much larger scale. These factors are taken into account, the aim being to secure only a fair return to the United States based upon the methods which are actually possible for the purchaser in each instance, and allowing him in all cases a liberal profit for the effort and capital which he puts into the enterprise.

#### SALES UNDER THE NEW LAW.

In accordance with a recent act of Congress, National Forest timber will hereafter be sold to farmers and settlers for use on their own land at the actual cost of making the sale. This is a significant development of the policy of the Government to make the timber resources of the Forests available under the simplest and least burdensome conditions possible for the use and benefit of local residents and industries, and particularly of the small operator. In each instance the amount of timber sold is determined by the requirements of the purchaser and the rate of cutting which is practicable for him. Sales to small mills usually cover from two to five years. Where, however, the purchase of a larger quantity with a longer cutting period is necessary to justify the investment which must be made in mill, roads, or other improvements or equipment, the Forest Service is glad to contract the amount required and to make the contract cover a longer period. In sales recently under consideration, where a large investment was necessary and the local market to be supplied permitted a cut of but 3,000,000 or 4,000,000 feet a year, the sale in one contract of a sufficient amount to supply the mill for 10 years has been approved. In such contracts provision is made to readjust the stumpage price by three or five year periods, the new rates being based upon the current market value of the products cut under the sale. This principle of increasing the amount of timber sold where the investment and markets and organization of the business require it accords with the fixed policy of encouraging permanent industries built upon the utilization of Forest resources and of providing a permanent supply of timber for the communities which such industries serve.

#### SIMPLICITY OF REQUIREMENTS.

The requirements imposed in sale contracts on the National Forests, while departing radically from the methods ordinarily followed in logging private lands, are exceedingly simple and always

enforced with regard to the practical requirements of the operator. Their object is solely to leave the cut-over land safe from fire and in such a condition that it will promptly produce a new crop of timber. The trees to be cut are always marked in advance by Forest officers. From one-fourth to one-third of the timber is reserved from cutting, consisting of young, thrifty trees wherever possible, as a nucleus for a second cut on the area and to insure its restocking. The operator is required to utilize the timber cleanly and to pile the slash for subsequent burning, in order that an otherwise serious fire danger will be eliminated. He must also handle his teams and trucks and logs so as not to destroy any more than is necessary of the young timber and seedling and sapling growth.

#### NECESSITY FOR CONTINUED NATIONAL CONTROL.

The opportunity of the small operator and the security of his business rest absolutely upon continued public control of the National Forests. If such control is abandoned, the future history of these areas will be one with that of similar timberlands which were not placed in National Forests. First comes entry under the timber and stone or homestead law; next, transfer of title to lumber corporations as soon as patent issues; and lastly, the locking up of the lands, in large holdings, from any form of development or use except as the business interests of a few powerful lumber companies may dictate. This is the unvarying story of unreserved timberlands all over the West. It has been repeated in every elimination of heavily timbered lands from the National Forests forced by local or political pressures. Heavily timbered land is not entered for farming. It is entered for the speculative value of its timber. It is often entered fraudulently by dummy claimants who are agents of lumber companies. Subsequently it is thrown together in larger and larger holdings. The timber corporation possesses the land. The independent operator disappears or becomes an employee.

If public control were withdrawn from the National Forests, the number of timber operators maintained in business on these areas would steadily diminish. As the land passed through the inevitable circuit, ending in a comparatively few large holdings, the independent operators, large and small—the men who own no timber and compete with the vested lumber interests—would disappear. No other course would so certainly eliminate the small operator from the lumbering industry. No other course would so surely restrict the possibility of competition or so surely extend the control of a few large corporations over the production of lumber in the United States.

On the other hand, nothing can so effectively conserve the opportunity of the small lumberman as public control of the Forests.



With such control there will always be a place for the small logger and manufacturer, and for more of them, not less, every year. Public control does not mean locking up, but using these resources; thousands of timbermen are using them now; and wherever he can be found, the independent operator is the agent sought by the Government for their use.

Finally, no form of public control can be so effective as that of the Federal Government. It is not so likely to be influenced by vested interests, which would do away with all public control and break up the Forests if they could. It is better able to meet the necessary cost of protection and administration to avoid sacrificing the permanency of these resources for immediate returns. It is more stable in its policies. Its purpose and methods are tried and known. No such uniform or certain results could be obtained under 20 separate State administrations or any other form of local control. It is to the Federal Government that the small timber operator should look for the sure and enduring protection of his interests in the National Forests.

# TRUCK SOILS OF THE ATLANTIC COAST REGION.

By JAY A. BONSTEEL,  
*Scientist in the Soil Survey.*

## THE TRUCKING DISTRICT.

The great winter garden which supplies the cities of the north-eastern States with the fresh vegetables demanded for consumption during the latter months of winter and those of early spring stretches in a narrow belt along the Atlantic coast from the vicinity of Savannah, Ga., to the southern portion of New Jersey. (Fig. 18.)

## CLIMATIC CONDITIONS.

The existence of this particular belt of territory, favorably situated with respect to intensive vegetable production, is the result of the concurrent existence of a number of favoring factors. In the first place, the climatic conditions within this belt render its successive portions from south to north earlier in the date of maturity for the different crops than any other regions in the eastern States which are located in the same latitudes. This arises from the fact that the land area of the region lies at low altitudes. From Savannah, Ga., to Camden, N. J., along the Atlantic coast there are no high lands. The coastal land areas rise from sea level with gentle slopes, and the vast Coastal Plain presents a low, nearly level, and unrelieved surface throughout what is known as the "flatwoods" section.

The streams of the region consist chiefly of narrow, tortuous tide-water embayments, in whose channels the tide rises to points removed 40 to 75 miles from the actual coast. The interstream land areas rise abruptly from these estuaries, either in the form of successive low river terraces, lying at altitudes of 10 to 35 feet above stream level, or in a single low bluff not more than 20 feet in altitude. These lower lands constitute narrow bands along one or both banks of the streamways. The more extensive upland areas, between streams, are monotonously level, or only slightly relieved by low, rolling swells and narrow sandy ridges. The entire coastal

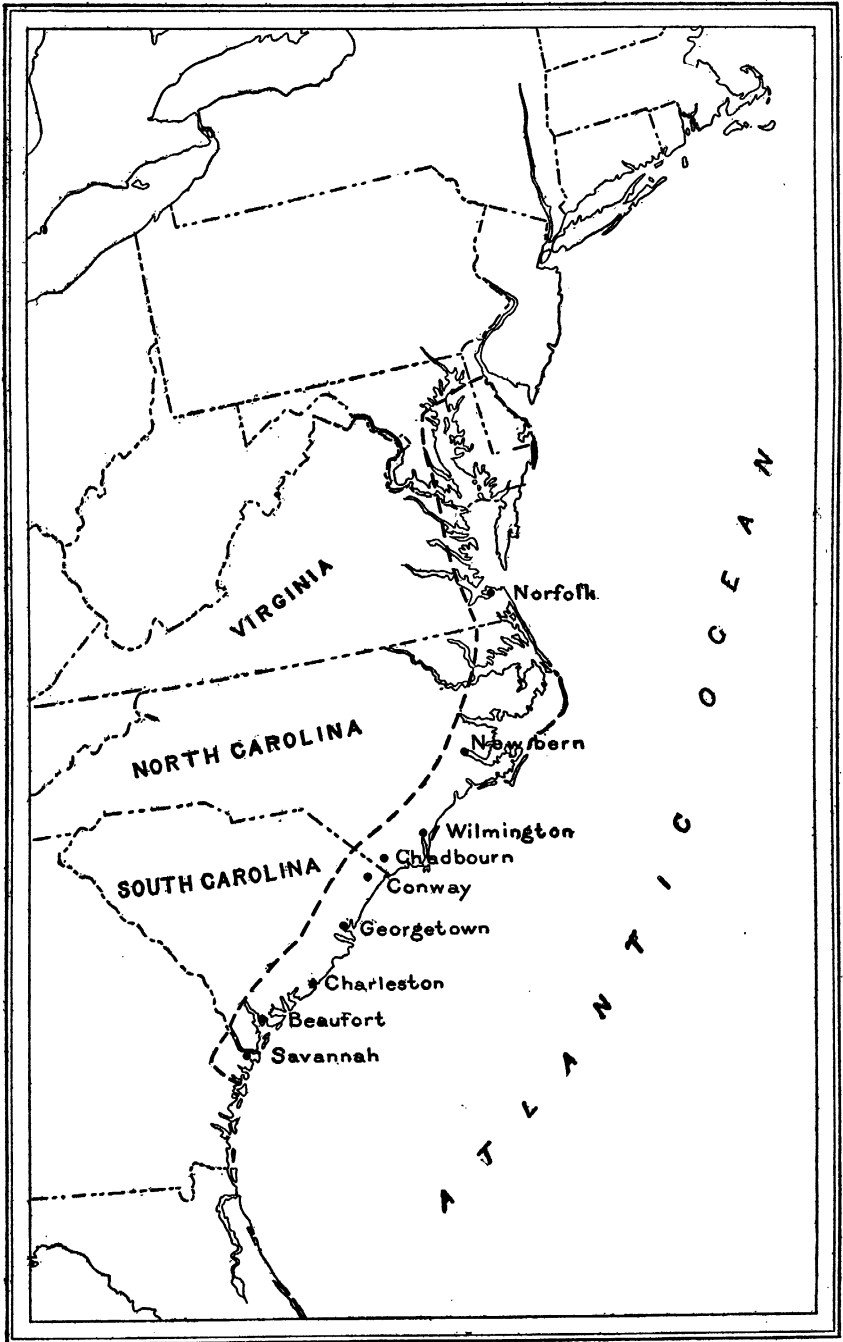

FIG. 18.—Sketch map showing location of the trucking district.

section slopes seaward from a line about 75 miles from the coast, with a decline of not more than 2 feet for each mile, until the land surface sinks below the waters of the ocean or of the marginal land-locked waters of the numerous sounds and bays. (Pl. XLIII.)

From these circumstances of topography the entire region lies at altitudes which insure the warmest possible climatic conditions for the respective latitudes. The same locations, if elevated to an altitude of 1,000 feet above the level of the tide, would be correspondingly placed in cooler climatic surroundings with a shorter growing season and greater danger from unseasonable frosts.

The presence of tide water, not only along the entire coast but at frequent intervals within the land area itself, lends an added influence to the favorable and protective climatic surroundings. These bodies of water lengthen the total growing season by periods which are to be measured by days and weeks, dependent upon the size of the protective water body. They also give a great stability to the annual changes of climate and reduce the tendency toward the occurrence of sharp destructive frosts at an unduly late date in spring or one correspondingly unseasonable in fall or early winter. They serve to lengthen the season over that of areas not so protected and to render the succession of seasonable conditions more dependable.

Added to these normal influences of low altitude and of protective water influence there is the great fact of the presence of the warm waters of the Gulf Stream, at no point far distant from this portion of the Atlantic coast and, in its middle section, approaching closely the actual shore line. The amount of added warmth which is contributed by this factor of local climate can not be accurately estimated, but it is one of the prominent factors in establishing this great out-of-doors greenhouse.

#### TRANSPORTATION FACILITIES.

The same physical features which contribute to the climatic availability of the region for vegetable production also favor the establishment of transportation lines for the delivery of the product to the market. The vegetables here grown are produced chiefly for the consumption of city dwellers in the more rigorous climates of the north. Transportation therefore plays a great part in the establishment of trucking regions and in the profits to be derived by the individual truck farmer. So rapidly do the factors of transportation alter the availability of lands for truck growing that lands otherwise equally adapted to vegetable crops are frequently valued at less than one-tenth the normal gardening price if they are located more than 6 or 7 miles from the point of primary shipment.

The low, level topography of the country along the middle Atlantic coast permits of the easy construction of rail lines for through traffic and the cheap construction of spur lines to intermediate territory wherever the agricultural capabilities of the new region are demonstrated and the prospect of tonnage appears good. This is well illustrated by the scores of miles of spur track which have been built into territory not served by trunk lines, but so favorably situated with regard to climate and soils that the trucking industry has preceded the track laying or has developed at the same time.

Land transportation is well supplied at present throughout the greater part of this long, narrow belt. It is not, however, the sole dependence of the truck grower. Some of the most extensive trucking districts are also well served by rapid and frequent steamboat transportation to northern ports. The two classes of service constitute factors which have given a somewhat local aspect to the development of established trucking areas. These occur in clusters around the principal seaports, since water transportation is there available and the rail lines naturally have terminal lines to the seaport cities.

#### CLIMATE AND TRANSPORTATION.

The two great influences affecting the establishment of southern vegetable growing have been well recognized from the inception of the trucking industry. They are the normal conditions which affect all crops and all classes of agricultural development.

#### GROWTH OF THE TRUCKING INDUSTRY.

The growth of the trucking industry has been relatively slow, covering a period dating from about 1840 to the present time. The earlier attempts at winter vegetable growing were very decidedly of an experimental nature. The men who undertook the work assumed great risks and many were but partially successful. They were either men who had removed from more northern localities and who needed to become familiar with new surroundings or they were men who had become habituated to the handling of crops other than the special vegetables of the trucker's business. The latter were familiar with the extensive tillage of large acreages, but they needed to acquire a new fund of experience with regard to the intensive management of small areas of vegetables. Consequently the last 30 or 40 years have constituted a period within which the trucking business has been experimentally developing a knowledge of soils, of crop adaptations, of soil-management methods, and of fertilizer practice. These problems have affected the development of territory already recognized as lying within the trucking zone, and very

strongly the occupation of virgin territory supposed to possess latent capabilities for the establishment of the trucking industry.

Recently it has been possible, through the completion of soil surveys in the potential trucking regions, to accumulate a fund of information regarding basic soil facts which will supplement the climatic and transportation information already at hand and thus serve to indicate the most available areas for the extension of vegetable production, the soils best suited to the growing of each of the special crops, and, to a degree, the methods of soil management which are requisite for the most economical utilization of such added lands. A very important function has also been performed by these soil surveys in forecasting the extent of the available trucking lands under any present conditions of demand for their products and of skill in their management.

#### TRUCKING SOILS.

##### SOILS OF THE NORFOLK SERIES.

Among all the truck soils in use or available along the middle Atlantic coast the Norfolk fine sandy loam easily occupies the premier place both with regard to its total extent and to its wide range of possible products. This soil has been formed as a sedimentary deposit, laid down under the waters of a more extended marine occupation, and later elevated to become a portion of the present land area. The mineral particles which constitute the soil and subsoil have been derived from a great variety of sources within the present Appalachian Mountain Region, the Piedmont Plateau, and the older and more elevated sections of the Coastal Plain. In consequence, the mineral sources of its soil fertility consist of a mingling of nearly all classes of minerals which may contribute to the nourishment of plants. Its inherent fertility has been well provided for through natural process of formation.

It is not so well provided with the organic remains which are usually denominated as "humus." In fact, one of the great problems in the management of this soil is that of incorporating organic matter in the surface soil.

Physically, the Norfolk fine sandy loam is almost ideally constituted for the intensive growing of crops and the easy mechanical handling of a soil mass. The surface soil to a depth which varies from 6 to 15 inches is a mealy, fine-grained, fine sand. It possesses enough material finer than sand to render the whole mass somewhat cohesive when moist, but not enough to cause the surface to bake and become compacted after spring or summer rains. It rarely or never forms clods, no matter in what condition of moisture it may be plowed or cultivated. These physical properties are of the ut-

most importance in the intensive cultivation of tender vegetables and in securing a proper surface and internal drainage of the surface soil.

The surface soil of this type grades imperceptibly downward into a more cohesive and dense subsoil, which, at a depth of 2 feet or more, becomes sufficiently consistent to be termed a sandy loam or sandy clay loam. This retentive subsoil is also a great factor in the control of the tillage methods and the use of the type. It serves to retain, at a reasonable depth, an abundant supply of soil moisture for crop use in the latter portion of the growing season without at the same time rendering the soil type poorly drained and water-logged. It serves to aid in the retention of the very soluble fertilizers, like nitrate of soda, which are commonly used to a considerable extent in vegetable forcing. It is favorable to the growing of many of the salad vegetables and for all plants which depend upon their foliage or fleshy substance for their commercial value.

As a result of these properties, the Norfolk fine sandy loam is of prime importance for the production of cabbage, lettuce, early Irish potatoes, cucumbers, radishes, turnips, carrots, beets, eggplant, and peppers. It may also be used for the growing of sweet potatoes, cantaloupes, tomatoes, peas, beans, strawberries, and squash. Other types should be preferred for the best development of quality and for early maturity of these latter crops.

The Norfolk fine sandy loam is so well suited to cabbage culture that it is locally known as the "cabbage soil" in the vicinity of Charleston, S. C. It is the chosen soil for lettuce growing in the vicinity of Wilmington, N. C. It is easily the premier soil for the production of large yields of Irish potatoes in all of the more northern portions of the trucking region. Farther south it is excelled by some other soils. It will not mature this crop at a period quite so early as the more sandy soils of the same and other soil series, but this is usually compensated by larger yields per acre.

The soil survey has encountered no less than 4,682,992 acres of this one soil type in the Southeastern and Southern States, and it is probable that a total area of 20,000,000 acres will ultimately be found to exist. Not one-tenth of 1 per cent of this total area is now occupied for truck-crop production, and it is probable that not 25 per cent is used for any agricultural purpose, aside from possible grazing.

The Norfolk fine sand is probably the earliest type of soil upon which the trucking industry is safely conducted. It owes this distinction of quickly maturing the crops planted to the fact of its physical composition. It is derived by the same processes and from the same materials as the Norfolk fine sandy loam, but it differs from that type in its texture of soil and subsoil. The surface soil to an average depth of 7 or 8 inches is a mellow fine sand. It is rarely

sufficiently loamy to be cohesive, unless immediately after a thorough wetting. This surface soil is underlain by a somewhat more compact fine yellow sand to a depth usually in excess of 2 feet. At this greater depth the subsoil materials grade into the characteristic sandy yellow loam or brittle sandy yellow clay which is characteristic of all of the loam members of the group.

The greater depth of fine sand as compared with the Norfolk fine sandy loam permits the absorbed rainfall to drain into the subsoil more completely, and the surface temperatures of the Norfolk fine sand are, therefore, somewhat higher than in the more loamy type. It is a soil which retains a moderate amount of soil moisture during the growing season, but is so well drained as to be warm and early in maturing its crops. It does not lend itself to quite so great a vegetative growth as the Norfolk fine sandy loam, but it is more valuable for the growing of crops which produce a seed or fruit for market uses. It is the best soil in the region for the production of early peas, snap beans, cantaloupes, watermelons, and extra early sweet potatoes.

Early Irish potatoes, eggplant, cucumbers, and even lettuce and cabbage are grown, but this is not the preferred soil for any of the latter crops. For extra early truck production it is doubtful if the Norfolk fine sand can be excelled in the more southern portions of the Atlantic coast region.

It is even less extensively developed agriculturally than the Norfolk fine sandy loam, from the fact that its uses as a trucking soil are only coming to be appreciated, and its low water-holding capacity has led to its incomplete development for the growing of the general farm crops. It has been encountered to the extent of 2,014,334 acres in the soil surveys already completed in the Southern and South-eastern States, and probably exists to a total extent of 10,000,000 acres in the Atlantic and Gulf seaboard States.

For the more northern areas, lying from the latitude of Cape Charles to the vicinity of New York City, the Norfolk sand has a high value for truck-crop production. It is even more coarse textured, porous, and completely drained than either of the two types already described. It is the most droughty and at the same time the warmest soil which may be occupied for successful trucking in any of the more northern truck-growing districts.

The too great porosity of the Norfolk sand may be artificially counteracted through the application of large quantities of stable manure and the plowing under of green manuring crops. This is a common practice where the type is used for trucking work. Then, moderate yields of very early maturity are secured from this soil. It is best suited to the growing of asparagus and watermelons, but may also be used for cantaloupes and sweet potatoes. With other



crops irrigation is a prerequisite for the production of a satisfactory acreage yield.

It is probable that less than 10 per cent of all the area of the Norfolk sand in the Atlantic States is used for any agricultural purposes, and that less than one one-hundredth of 1 per cent of its available acreage is utilized for vegetable growing. It possesses great possibilities for further development where water is available for irrigation and where a near-by market will assimilate the possible products.

All three types of the Norfolk series occupy upland positions and are among the soils naturally well drained in the region where they occur. This does not mean that every acre of each of these types is adequately drained for trucking uses. It simply means that the soils of the Norfolk series possess drainage advantages over most of their associated types and series of soils.

#### SOILS OF THE COXVILLE SERIES.

The soils of the Coxville series usually occur in close association with those of the Norfolk. Their surface soils present much the same appearance, although rather darker in color as contrasted with the pale yellow of the Norfolk soils. The subsoils of the Coxville series are, however, totally different. They almost invariably consist of rather compact sandy clays, mottled gray, yellow, and red, as contrasted with the yellow subsoils of the Norfolk series. The Coxville soils usually lie at somewhat lower elevations in the Coastal Plain than the Norfolk and occur extensively in the seacoast sections of Georgia, South Carolina, and North Carolina. They rarely attain an elevation of more than 50 feet above tide level and usually lie at an altitude of 5 to 25 feet above adjacent drainage ways.

The Coxville fine sandy loam is most extensively used for the production of truck crops of all soils of the series. The surface soil to an average depth of 6 to 10 inches is a gray or black sandy or fine sandy loam. It is well charged with partly decayed organic matter, and it is usually soft and friable and not liable to bake or clod. Immediately under the surface soil there is usually a gradation into a gray or drab sandy clay layer which, at depths greater than 2 feet, becomes a mottled gray, yellow, and red compact sandy clay. The colorations of both surface soil and subsoil are certain indications of less complete drainage than is possessed by the soils of the Norfolk series. The accumulation of organic matter in the surface soil shows a moist to swampy surface condition, while the gray and mottled colors of the subsoil indicate that the access of air has not been sufficiently free to oxidize or "rust" the iron-bearing minerals to the characteristic yellow or red colors. That the subsoil is now possessed of a fair degree of internal drainage is shown by the partial mottling of the subsoil where air has penetrated into crevices within it.

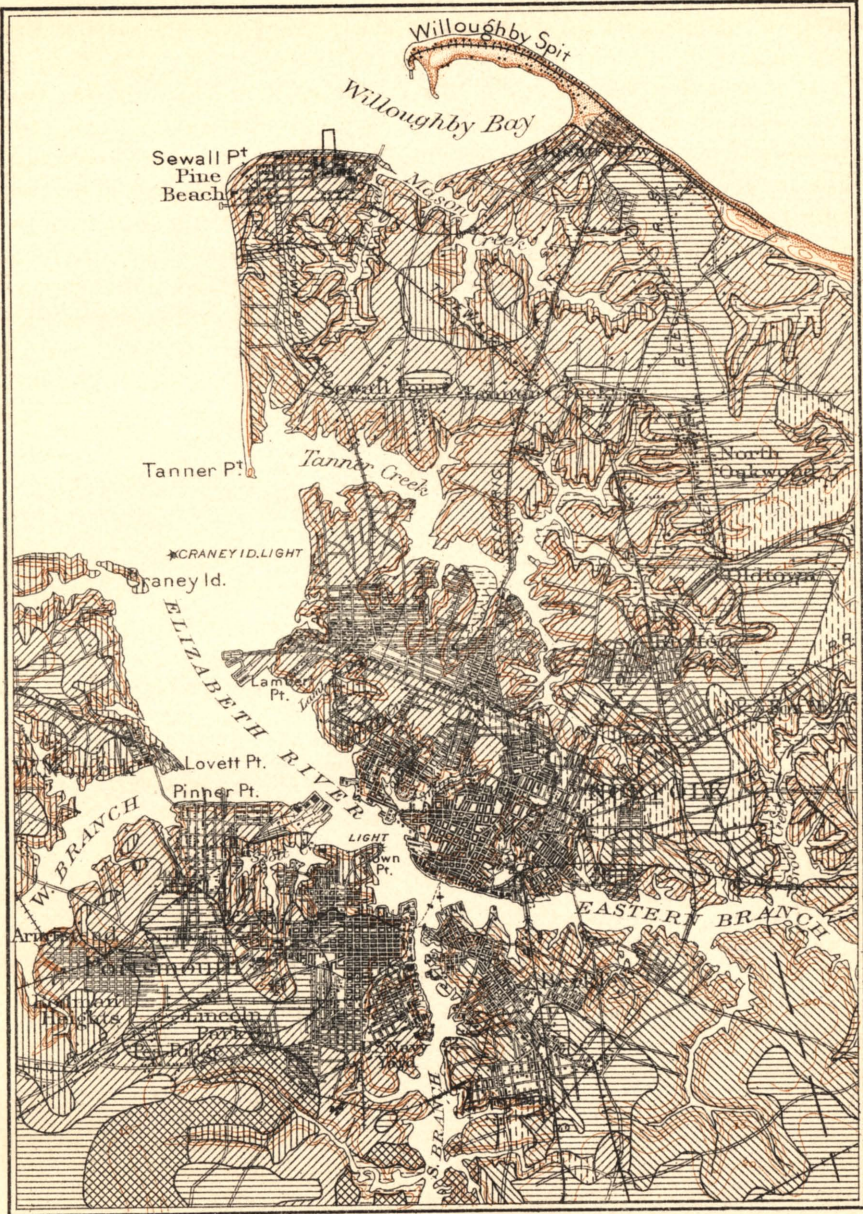

**CHARACTERISTIC LOCATION OF THE TRUCKING SOILS OF THE NORFOLK AND PORTSMOUTH SERIES.**

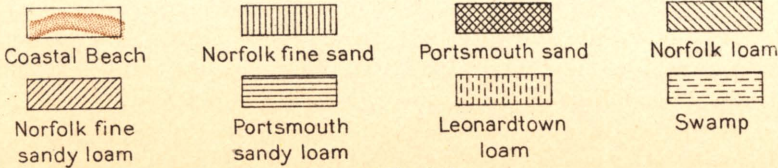

JULIUS BIEN CO. LITH. N.Y.



FIG. 1.—A CROP OF EARLY IRISH POTATOES ON COXVILLE FINE SANDY LOAM, MYRTLE BEACH, S. C.

[Cotton is planted between the rows of potatoes just before they are harvested.]

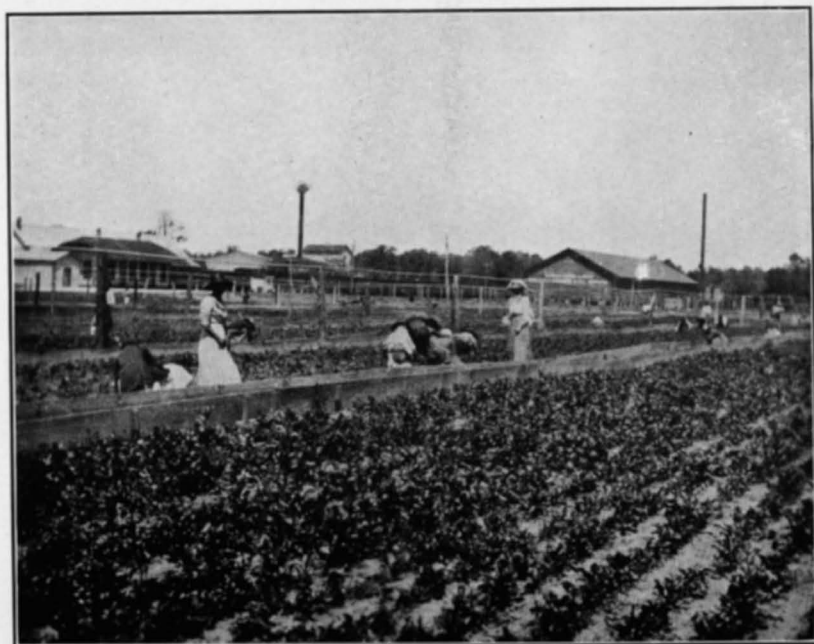

FIG. 2.—THINNING BEETS, BEAUFORT, S. C.

[A crop of bed lettuce has already been harvested from this ground.]



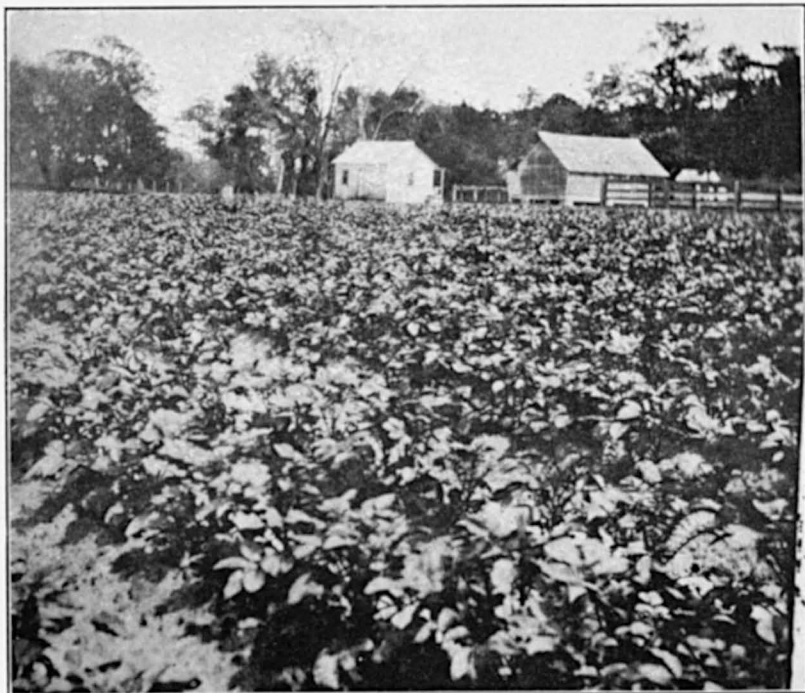

FIG. 1.—EARLY IRISH POTATOES ON NORFOLK FINE SANDY LOAM, NEAR CHARLESTON, S. C.  
[This is one of the leading crops of the Charleston trucking district.]



FIG. 2.—WINTER CABBAGE ON NORFOLK FINE SANDY LOAM.  
[The "cabbage land" near Charleston, S. C.]



FIG. 1.—HARVESTING FIELD LETTUCE ON NORFOLK FINE SANDY LOAM NEAR CHARLESTON, S. C.

[This is an important though subordinate crop in this trucking district.]



FIG. 2.—HARVESTING FIELD OF BEETS ON NORFOLK FINE SANDY LOAM, CHARLESTON, S. C.

[Used in succession cropping with winter cabbage and cucumbers and cantaloupes as summer crops.]



FIELD LETTUCE, CASTLE HAYNE, N. C.  
[Nearly 40,000 heads were grown upon this area.]



FIG. 1.—KLONDYKE STRAWBERRIES ON COXVILLE FINE SANDY LOAM NEAR CONWAY, S. C.  
[The Klondyke berry is particularly suited to production on this soil type.]



FIG. 2.—UNCLEARED SAVANNAH LAND, NORFOLK FINE SANDY LOAM, IN EASTERN NORTH CAROLINA.

[Worth less than \$10 per acre in this condition, but capable of producing \$1,000 worth of truck crops per acre in a single year.]

Owing to its low-lying position, to the large amounts of organic matter usually present in the surface soil, and to the presence of a compact and clayey subsoil near the surface, the Coxville fine sandy loam is decidedly retentive of soil moisture. It is, therefore, best suited to those truck crops which occupy the land for a long growing period, and for those classes of vegetables which produce succulent foliage or fleshy tubers or roots. It has been used with great success for the growing of early Irish potatoes at some points in South Carolina. (See Pl. XLIV, fig. 1.) The common practice is to plant the potatoes in rows spaced  $5\frac{1}{2}$  to 6 feet apart. The hills are set 18 inches apart in the row. The rows are ridged and the fertilizer applications are made in the crown of the row at the time of planting. The crop is cultivated until the first blossoms appear. At that time a row of cotton or of corn is planted midway between the rows of potatoes and allowed to mature after the potato crop has been harvested. This system of double cropping is applicable over nearly all of the area of the Coxville fine sandy loam, and its successful development has given a high commercial and agricultural value to the type.

For the best results in crop yields it is found necessary to under-drain the Coxville fine sandy loam. This may be accomplished through the laying of tile drains at intervals not greater than 100 feet between lines of tile and at a depth not less than 2 feet from the surface. Such tile drains may have their outlets into open ditches or into larger main lines of tile ultimately discharging into some of the numerous natural drainage ways which intersect practically all of the region chiefly occupied by the soils of the Coxville series.

The Coxville sandy loam has not been extensively used for the production of truck crops, but it offers opportunities of great value. The surface soil consists of a somewhat coarser and more porous grade of sand than that of the Coxville fine sandy loam. Otherwise the two soils are very similar. The Coxville sandy loam would also constitute a very good Irish potato soil and would be well adapted to crops of cabbage and of lettuce. These would mature at a somewhat later date than upon the soils of the Norfolk series in the same localities. It is an especially good soil for the growing of certain varieties of strawberries, particularly the Klondyke. This berry is successfully grown upon both the Coxville fine sandy loam and the Coxville sandy loam. It is not so successfully produced upon any soil of the Norfolk series. The great berry-producing sections which center around Conway, S. C., and Chadbourn, N. C., are developed chiefly upon these two soils of the Coxville series.

The berries are principally grown under the matted-row system, with the rows laid off  $3\frac{1}{2}$  feet apart and the plants set at intervals of about 20 inches in the row. The best growers usually pre-



cede the setting of a field to berries by the cultivation of cowpeas, vetch; or some other leguminous crop. Large quantities of commercial fertilizer are applied at the time of setting the plants and, in some cases, during intervals between the growing seasons. The berries are shipped from this territory from the middle of April to the first of June.

When crop yields are normal and prices for the fruit are well maintained during the shipping season the best growers frequently harvest from \$350 to \$500 worth of berries per acre, and the high record of \$1,000 worth of strawberries has been attained.

The soils of the Coxville series await more extensive drainage operations before they will attain the importance as truck soils which their inherent capabilities warrant.

#### SOILS OF THE PORTSMOUTH SERIES.

The soils of the Portsmouth series are closely associated with those of the Norfolk and Coxville series throughout the Middle Atlantic coast section. They usually occupy depressions in the upland portions of the territory along the immediate coast line and for a distance of approximately 50 miles inland. The mineral matter which constitutes the basis for the soils of this series has been derived from the same sources and deposited in the same manner as in the cases of the Norfolk and Coxville soils; the subsequent history of the soil-forming material has been totally different. Owing to the flat surface of the country and to its slight elevation above the main drainage channels, the tributary streams are infrequent and have not become sufficiently established rapidly to remove the accumulated rainfall. This gives rise to extensive areas of true swamp lands and to far greater areas which remain in a semiswampy condition until well into the drier months of summer. Such areas occupy the shallow depressions with obstructed drainage, the margins of the true swamps, and such areas as are included within the low swells or ridges which are characteristic of a considerable portion of the region under discussion.

Within such wet areas there has been a long-continued accumulation of the remains of an abundant vegetation. This surface deposit of vegetable matter gives a uniformly black or very dark-gray appearance to all of the soils of the Portsmouth series. In fact, all of these surface soils may be termed "mucky" or are at least well charged with partly decayed organic matter. With this accumulation of vegetable remains is mingled a considerable amount of mineral matter in various stages of subdivision, and a group of mucky soils results.

In practically all cases the subsoil of the Portsmouth group consists of an ash-colored or pale-gray sand, sandy loam, or clay.

Drainage has been so incomplete there has been little or no admission of air into the deeper subsoil, and it retains its uniform gray color without any "rusting" and oxidation of the iron-bearing minerals. In fact, this coloration is sometimes even emphasized through the leaching effect of the surface waters, which penetrate the subsoil in a condition highly charged with organic acids and which, consequently, tend to dissolve and to remove any iron coloration which might otherwise exist.

Until they are reclaimed by artificial drainage the soils of the Portsmouth series are rarely available for any utilization for the growing of the truck crops. This removal of surplus water may be accomplished through the establishment of open ditches which lead into local drainageways. Complete drainage, adequate for the successful production of intensively tilled crops, can be accomplished only through the installation of rather complete tile underdrainage.

The soils of the Portsmouth series in their natural state are usually covered with a thick growth of deciduous trees and a dense undergrowth of shrubs, vines, and rushes. They are consequently expensive to clear and also to drain. This has resulted in the preferential development of other soils for general and special agriculture in the region of their occurrence. It is only where other more easily subdued lands have been occupied that there is any great demand for these soils. In such areas as have been rather completely developed a considerable progress in the utilization of the Portsmouth series soils has been made. This is particularly the case in the more northern portions of the Atlantic Coastal Plains. Thus, in the vicinity of Norfolk, Va., and upon the eastern shore of Virginia and Maryland, as well as in Delaware, the Portsmouth sandy loam has come to be used extensively for the growing of certain truck crops. Among these the Irish potato takes first rank. The crop does not mature at as early a date as upon the associated Norfolk soils, but the yields secured are even greater than in the case of the Norfolk fine sandy loam, especially where the Portsmouth sandy loam has been well drained and fertilized. Yields of 50 to 60 barrels an acre are not unusual. The potatoes are sometimes of inferior quality, being liable to cook to a dark color and to be hollow. This arises from excess organic matter in the soil and from an excess of moisture during the last few days before digging. It is a fault which is reduced or eliminated by proper drainage and the use of the proper fertilizers, notably the sulphate of potash. This soil is, therefore, capable of more extended use as a medium-season potato soil.

Strawberries are extensively grown upon well-drained areas of the Portsmouth sandy loam in the southern part of Delaware. The Gandy berry is the variety which has been used most extensively.

The type may be said to be better suited to the growing of a fine quality late berry, with heavy yields, than to the production of an early berry which depends for its value upon early marketing. It is not uncommon for experienced berry growers to secure a crop giving a net income of \$200 per acre from the Portsmouth sandy loam, while this value is frequently exceeded under the most favorable conditions.

The Portsmouth sandy loam has not been used to any extent for other truck and small-fruit crops, but it is certain that cabbage and lettuce may be successfully grown upon it where the market demands justify the production of a rather late crop. It should be available for the growing of fall crops of these vegetables in all of the more northern localities where it occurs.

It is probable that not 10 per cent of the total area of Portsmouth soils has been reclaimed and used for any agricultural purpose. The amount used for truck production is so insignificant as not to permit of any numerical estimate. The usable area of the soils of this series is therefore very great, and the crops which may be grown depend rather upon the adequacy of drainage than upon any other factor aside from transportation facilities.

#### TRUCKING DISTRICTS.

It is difficult to secure any definite estimate of the total area of land now devoted to the production of winter and early spring vegetables in the Atlantic coast region. This arises from the fact that the crops are grown in rapid succession upon the same land, and the same acre may bear a crop of winter lettuce, a spring crop of radishes, a summer crop of cucumbers or melons, and another fall crop of lettuce. This multiple cropping of the land gives rise to a report of many more acres of the various crops than there are acres of land devoted chiefly to trucking. Another difficulty in making a just estimate of the lands so used lies in the fact that the areas are annually expanded or restricted to a very considerable degree through climatic accidents, particularly those of precipitation. If the planting or transplanting season for the early spring crops happens to be either excessively wet or excessively dry the acreage in any one locality may be seriously reduced for that year, and general farm crops may be used to occupy the trucking lands. In a succeeding year favorable climatic conditions and a heavy market demand may give rise to much more extensive planting. It is therefore practically impossible to give other than very general estimates of acreage, and these may be stated only for the longest established and most uniformly stable trucking districts.

It is probable that approximately 1,500 acres of land are devoted to truck and market-garden crops in the vicinity of Savannah, Ga. The chief acreage is devoted to early Irish potatoes. Snap beans and garden peas are also grown. Strawberries are produced chiefly for the local markets. Some onions are grown, while sweet potatoes and melons are produced for local consumption. The soils suited to trucking and market gardening exist to the extent of 90,000 acres in Chatham County alone, and the facilities for transportation to market include both rail and boat transportation. It may be said that there is an excellent opportunity for the development of this class of agriculture, not only in that county, but also in other nearby counties of eastern Georgia.

Around Beaufort, S. C., a thriving trucking business has been built up during the last 10 years. The soils and climate are well suited to this industry, and the progressive truckers of the region have improved upon natural conditions by a rather general use of overhead irrigation systems. Such a system is shown in Plate XLIV, fig. 2. Lettuce is the chief crop grown. Beets, radishes, peas, beans, and early potatoes are also raised. Possibly 6,000 acres of land are now occupied for trucking purposes in the Beaufort district. Less than 5 per cent of the available land has yet been utilized. Transportation facilities are fairly good.

The Charleston (S. C.) trucking district is one of the older localities, and it has established a well-deserved reputation for the growing of early spring cabbage and of cabbage plants for both fall and spring planting at more southern and more northern cabbage-growing points. Millions of cabbage plants are annually shipped from the Charleston trucking district to all of the Eastern States. It is estimated that an acreage in excess of 20,000 acres is annually devoted to truck crops upon the mainland and the sea islands around Charleston. The largest acreage is given to Irish potatoes (Pl. XLV, fig. 1); the next and nearly equal acreage is occupied by cabbages (Pl. XLV, fig. 2); cucumbers, beans, peas, and sweet potatoes also occupy acreages ranging from 500 to 2,500 each. Asparagus is harvested from nearly 1,000 acres of land. The total value of the crops harvested has been estimated at \$3,700,000 by the Charleston Chamber of Commerce. This is in excess of \$150 per acre for all classes of vegetables and for all conditions of crops, from the best to those which were practically failures. Excellent crops of field lettuce and of shipping beets are shown in Plate XLVI, figs. 1 and 2.

The opportunity for the extension of trucking acreage around Charleston is good. The soil survey of a restricted area, made in the vicinity of the city in 1905, shows that there are more than 100,000 acres of Norfolk fine sand and Norfolk fine sandy loam within the area of the survey. The area included only a part of

Charleston County. It is thus easy to estimate that the present trucking area of this district could be doubled if only the most accessible and best suited lands were used.

Trucking has only recently been established as an important industry in the other seacoast counties of the State, yet Georgetown County shows over 400 acres of strawberries alone in the census year. A field of Klondyke berries is shown in Plate XLVIII, fig. 1. Horry County grows approximately 2,500 acres of strawberries each year, and Columbus County, immediately across the line in North Carolina, produces berries from a considerably larger acreage. Some other truck crops are also grown in all of these counties. Yet less than 1 per cent of the farm-land area of the general region is used for truck production. It is almost literally true to estimate that, so far as land area is concerned, the undeveloped trucking lands of these coast counties of North Carolina and South Carolina number hundreds of thousands of acres.

The trucking industry around Wilmington, N. C., has been established since 1875, but the chief growth of the area did not commence until 10 years later. The Wilmington district is especially noted for its bed and field lettuce crops. The former are grown under canvas cover to prevent their injury by the mild winter frosts. The lettuce matures in early March. The field crop matures a month to six weeks later. From a half acre of bed lettuce one grower harvested lettuce to the value of \$1,756, or at a rate in excess of \$3,500 per acre, in the spring of 1912. Numerous crops of field lettuce have yielded at the rate of \$1,200 per acre when climatic and market conditions were both favorable. One of the best of these fields is shown in Plate XLVII. The field lettuce does not command so high a price, and the cash returns are correspondingly less, although the yields may be as large or larger.

Early Irish potatoes are an important crop in this district, and the spring crop is harvested in time for the production of a forage or cotton crop during the summer season. The yields from the Norfolk fine sandy loam range from 40 to 65 barrels per acre. In one instance a progressive trucker combines winter and spring trucking with the production of summer forage crops for the feeding of a fine herd of dairy cattle. All but a portion of the grain ration is raised on the farm, and a trucking business is combined with good dairy farming, to the financial benefit of both. The maintenance of the crop-producing power of that land is assured.

A variety of other truck crops are grown in small acreages, and it is estimated that 6,000 to 7,000 acres of land are occupied for truck and fruit crops. Soil surveys in the district have shown the existence of 40,000 acres of available land for trucking in New Hanover County alone, while several times that amount of such soils exists in the near-by counties of North Carolina.

Trucking has been entered into as a specialized form of farming at numerous other points in the State, particularly near Newbern. Some of the northeastern counties of the State are now developing trucking lands. Yet throughout eastern North Carolina it may be said that there are 100 acres of good trucking soil undeveloped for every acre that has yet been utilized.

The Norfolk, Va., trucking area is probably the best known as well as the oldest trucking district of the Atlantic coastal region. It is estimated that nearly 35,000 acres of land are devoted to truck crops in this district, which comprises parts of Princess Anne, Norfolk, Nansemond, and Isle of Wight Counties, in Virginia. The gross returns from this business exceed \$8,000,000 each year.

The early Irish potatoes are the chief crop in acreage and value. The value of this crop usually exceeds \$2,000,000. Strawberries are next in importance, giving an annual return in the vicinity of \$1,000,000. Kale and spinach, grown as winter crops, are harvested to a value of nearly \$1,000,000 each year. Cabbage, peas, and beans constitute the other more important crops, although cucumbers, radishes, beets, melons, and sweet potatoes are grown on a considerable acreage.

It is probable that the available land supply for trucking purposes has been more nearly utilized in the Norfolk district than in any of the other trucking regions of the Atlantic coast region. Yet there exists in the northern portion of the counties named an area of the Portsmouth and Norfolk series in excess of 110,000 acres and in the vicinity of the port of Norfolk not less than 250,000 acres of these peculiarly truck-soil types. The extension of the trucking industry in the district is more dependent upon the furnishing of adequate drainage and added local transportation facilities than upon available soil acreage.

In the absence of detailed soil surveys of the counties of eastern Virginia and southern Delaware, it is not possible to give a detailed statement of the unused but available trucking lands of the Virginia-Maryland-Delaware Peninsula. Yet it is known that not 1 acre in 50 available for vegetable and small-fruit production is yet utilized for growing these crops. The soils are well adapted to trucking, and the climate is fairly favorable, while the transportation facilities are excellent, and both the time and distance of the haul to the great city markets are small.

#### AVAILABLE TRUCKING LANDS.

While it is still impossible to give an accurate and detailed statement of the acreages of land suited to the production of winter and spring vegetables in the Atlantic coast region, it may be stated posi-

tively that the areas now utilized for such purposes constitute only a fraction of 1 per cent of the total land area which may ultimately be made available.

The first requirement for the development of these lands will be a market demand which shall justify the increased production, through paying a price for the product commensurate with the expenditures and risks undertaken by the producer. This may be attained through the natural increase in the consuming population and, to a more marked degree, through the extension of the markets to hundreds of thousands of city dwellers who never taste the fresh vegetable products at the periods of the year when these crops are placed upon the market. A reduction in city price is essential to secure this latter extension of the business. This constitutes one of the greatest problems of food distribution remaining to be solved.

Added transportation facilities will probably be furnished as rapidly as a stable increase in production is assured. This has been the history of the development of the trucking business for the last ten years. Extension of transportation lines into new territory will accompany the general development of the territory.

Extensive community and private drainage works must be undertaken before some of the best soils for trucking are rendered available in this section. The level savannah lands, the pocosons, and the swamps imperatively require drainage. (See Pl. XLVIII, fig. 2.) The more elevated uplands will frequently be benefited by more complete drainage, and many of the tidal swamps, occurring along the streams and at the estuarine mouths of the larger rivers, may be reclaimed, ultimately, for the production of concentrated forms of human food.

It may be said that capital for development and human labor for the working of the lands are the chief local problems attendant upon the wide extension of food production in the general region. There is land enough and climate sufficiently favorable to return the vegetable and fruit supplies required by many times the present population of the country. Lack of suitable lands is eliminated for many generations, and further development awaits upon the solution of economic problems rather than upon the discovery of suitable soils.

## SEED COLLECTION ON A LARGE SCALE.

By HENRY H. FARQUHAR,

*In charge of planting, District 1, Forest Service.*

### UNPRODUCTIVE FOREST LANDS.

There are within the National Forests approximately 15,000,000 acres of land at present unproductive but capable of supporting tree growth. These areas will serve their highest use only when made to produce forests; now they are covered with worthless brush or are bare of vegetation. In many places fires have swept the forest away, and on these lands, scattered throughout the forests from Florida to Alaska, trees will come again through natural reforestation, and in a reasonably short time if fire is kept out. At least half of the area, however, aggregating 7,500,000 acres, can be reforested only through artificial planting, either of seed sown directly where the new forest is to grow, or of young trees raised in nurseries and set out as soon as they are sturdy enough to withstand the hardships with which they have to contend.

### QUANTITY OF SEED NEEDED.

No matter which of these two methods is used to get the new stands of timber, it is plain that a vast lot of seed is needed. During 1911, as a case in point, the Forest Service sowed seed on over 23,000 acres, and planted over 2,000 acres with young trees. While the seed of different species have widely differing weights, it is fair to say that the sowing averaged not less than 6 pounds to the acre; and to raise the young trees which were set out, about 2 pounds of seed went for each acre of planted trees. There were required, on this basis, 143,401 pounds of seed. As a matter of fact, the Forest Service had on hand 161,880 pounds of seed, of which the stupendous quantity of 107,780 pounds, or more than 53 tons, had been collected on the National Forests in the fall of 1910. The remaining 54,100 pounds, mostly of European species suitable for introduction into this country, were purchased in the open market. In 1911, which was not a good seed year, the Forest Service collected 63,061 pounds of seed.



The aim is to restore to the National Forests the most valuable timber trees suited to each region—conifers in general and the pines in particular, because they grow rapidly and yield good lumber. Taking the pines as a whole, the seeds run about 30,000 to the pound, and it takes about a bushel of cones to yield 1 pound of cleaned seed. These figures are only approximations, but they serve to show the magnitude of the task of collection. For example, to store the seed gathered for the planting of 1911 would require a hypothetical bin 10 feet square at the ends and more than a quarter of a mile long.

#### MAGNITUDE OF THE TASK.

At the rate of 30,000 acres a year it would take almost three centuries to complete the task of reforestation now before the Forest Service. This rate, however, will be greatly accelerated; the plantings which have been accomplished are, in the light of the work still to be done, merely experimental. This experimental work alone has required scores of tons of seeds; the work to come is going to take hundreds of tons.

Where, then, will all this seed be got? To purchase it, even if it could be had of dealers, would cost an immense amount of money. Experience has shown that it can be collected by the regularly organized force of the Forest Service much more cheaply than it can be bought in the open market. Yet it can be collected at small cost only because the work is carefully organized and painstakingly supervised as to the smallest details. Many of the heavier tasks of seed collection are carried on as distinct lines of work, because much concentration is required to gather from 5,000 to 15,000 pounds of seed of a single species, especially when the seed of that species ripens and falls in a short time and the cones must be gathered before they open. On the other hand, some of the collecting needs no peculiar organization, and forms a part of the routine duties of the forest rangers and guards.

#### WHOLESALE OPERATIONS REDUCE UNIT COSTS.

It has been found that a large force concentrated on seed collecting, especially when seed is plentiful, materially reduces the cost. For instance, in the use of horses in the transportation of cones the weight of the load is no great matter, and the greater the quantity of available cones the smaller the cost per pound of seed.

The cost of seed of the species most used, when gathered by the Forest Service, averages about \$1.65 per pound. The average cost of the same species from seed dealers is \$3. Western yellow-pine seed has been the cheapest, at 80 cents a pound, but during abundant seed years it has cost much less than that. Western yellow pine costs about

\$1.65 from the dealers, and at its lowest does not sell for less than \$1 a pound. Thus it can be seen that the seed from commercial houses costs about twice as much as that gathered by the Forest Service. It is not too much to expect that with improved methods and with even greater efficiency in organization the cost of seed collecting on the forests can be further reduced. (See Pl. XLIX.)

#### FORETELLING THE CROP.

The first step in any campaign for seed collecting is to forecast the crop. This is necessary, because forest trees do not bear seed crops every year, nor do they have a definite periodicity in any region. With some species, for example, while it may be said that there is a seed crop at 7-year intervals, as a matter of fact the period between good crops may be from 3 to 11 years. Conifers, in particular, are very irregular in seed production; and while a few cones may be borne each year, heavy crops come with no regularity, but vary with climatic and other external conditions. During scant years not only is the seed produced in small quantities, but there is a concentrated demand on it by birds and rodents, so that it is hard to get. What can be had, too, is likely to be of poor quality because of an additional concentrated attack by insects.

With many species the plans for seed gathering can be made a year in advance, because the cones take two years to ripen; that is, they are small and green the first year and remain on the trees to grow and ripen in the fall of the second year. Even with seeds that form and ripen in one season the forecast is made not later than the middle of July, when the rangers throughout the country report, on a special form, the prospects of the crop, what species are abundant and on what particular areas, the accessibility of the areas and the cones, and the probable cost of collecting. In addition to reports on these general points they give specific information that might be of service. If, for example, an area of good seed production is to be logged at the time the seeds ripen, there is an excellent opportunity to collect the cones from the felled trees.

#### GATHERING THE CONES.

If it is decided to collect the cones on a large scale on any given area, crews have to be gathered, camps established, a commissariat provided, and a wagon or pack train organized to carry the gathered cones to the most convenient point for storage or seed extraction.

There are three principal methods of getting the seed—from squirrels' hoards, from the standing trees, and from felled trees.

## SQUIRRELS HELP THE HARVEST.

Squirrels' caches afford a supply that is quickest and easiest to get, and which is most likely to be good, because the canny little beasts know which cones have the plumpest seeds. (Pl. LI, fig. 1.)

Without the intervention of man squirrels are an enemy of the forest; with man's efforts at reforestation they become a help, because they lay by an enormous supply of food. In fact, when cones are abundant squirrels lay by a great store—much more than they can eat during the winter. When the cones are getting ripe on the area where there is a big crop, there is a continual dropping of cones, even from trees on which they ordinarily hang tight for several years. The squirrels are cutting them off and dropping them to the ground, to lie there until a great lot are scattered beneath the trees. At this time the collecting is easiest. When most of the cones are down the small harvesters transfer their operations to the ground and scurry the cones off to their hiding places. (Pl. L, fig. 2.)

These caches are cleverly hidden and well chosen to keep the cones during the winter. Generally they are in moist places in order that the cones may not dry out and open to spill the seeds. They are in hollow logs or stumps, or beside down trees, and usually, to the great convenience of the cone gatherers, there are cones of only one species in each store.

The cones are not merely thrown into these caches, but are packed carefully in an orderly array, so that each hoard contains a great many more cones than one would think from a glance at the top layers. The officers of the Bitterroot National Forest report that the squirrels there actually store the cones under water.

## CONES FROM STANDING TREES.

When cones are collected from standing trees it means hard, slow work at climbing to cut off or knock off the cones; or they may be knocked off low, bushy trees in the open with a pole in the hands of a man on the ground. With these low-spreading trees a long-handled tree pruner is an excellent implement, because with it the outermost branches, which bear the largest number of well-filled cones, can be clipped off and the cones taken from them on the ground. Very rarely, indeed, are trees cut for the cones they bear. In the first place, it is slow and laborious, and in the second place the seed secured would scarcely be worth the price of the tree, unless the tree itself were a poor specimen, or one whose removal would benefit the surrounding forest. On an average, a single tree bears no more than  $2\frac{1}{2}$  bushels of cones, or  $2\frac{1}{2}$  pounds of seed. For tree climbing there is needed a good pair of climbing irons such as telegraph

linemen use, and a pair of heavy gloves to protect the hands from the spiny cones as they are pulled off. (Pl. L, fig. 1.) At best, however, the climbing method is not only unsatisfactory but dangerous.

#### CONES FROM FELLED TREES.

Where trees are being cut in logging operations and are full of cones there is an excellent chance for the seed collectors, and one of which advantage is always taken. It is a cheap and rapid operation to go from tree to tree, pulling the cones from the tops as they lie on the ground and putting them in bags.

As the cones are gathered they are tied tightly in the sacks by the collectors and left beside trails in the woods to be taken up by teams or pack horses and transported to a central station where storage bins are provided. From these bins they go to the drying houses and from there to plants where the seed can be extracted by some thrashing process when that is necessary.<sup>1</sup>

The aim of the Service is to get as much seed as possible at the lowest cost. It means that the organization of an army or of a big industrial concern has to be put into effect in a short time and for a very brief period—or during the interval between the ripening of the seed in the late fall and the coming of severe winter weather which stops operations. Everything is calculated to a unit basis of cost per pound of seed or bushel of cones.

#### ONE EXAMPLE OF BIG COLLECTING.

A single example of a big seed-collecting campaign and its organization was furnished on the Kaniksu National Forest, Idaho, in the fall of 1911.

It was a good seed year for western white pine (*Pinus monticola*), and 20,000 bushels of cones were needed for the plantings anticipated in 1912. Reports from six National Forests, three in Montana and three in Idaho, indicated excellent opportunities. Since it was best to center on one forest, these six were further reconnoitered to find out which one offered the best chance. The Kaniksu was chosen because it gave in one area the best combination of favorable factors—abundant seed; large, contiguous bodies of the single desired species; easy topography; good and sufficient roads and trails; ranchers who might furnish labor, teams, and food; nearness to centers of labor and commissary supplies.

The cone crop was not only exceptionally large, but the cone-bearing trees were not confined to the lower levels, but extended up

<sup>1</sup> For an account of these further processes, see Forest Service Bulletin 98, Reforestation on the National Forests, by William T. Cox.

the long, gentle slopes to the tops of the divides. Moreover, the squirrels whose hoards were to furnish the supply had to confine their cone-cutting to the one species because all the others had poor seed crops.

The Forest Service trails were in good shape, and there were other roads and trails that needed only a little working to make them available; the few temporary roads needed in addition to the existing ones were readily constructed because of the easy grades. These trails not only aided the pickers in moving about from place to place, but they served as lines of deposit for the filled sacks, ready of access to pack trains. (Pl. LI, fig. 2.) Also, there were logging roads and roads to mining camps. The location, too, was comparatively near a railroad which brought in help and supplies.

#### THE LABORERS EMPLOYED.

In the immediate vicinity there were two ranger stations and the homes of nine ranchers. These ranchers furnished the most reliable labor—men who were at home in the woods and were in familiar territory. More than all, the ranchers were indispensable in furnishing hay, vegetables, and fresh meats to the camps, at reasonable prices. They could furnish only a small part of the labor necessary to collect the cones before the winter would set in, so it was necessary to call on outside help. The logging camps in the vicinity had not yet opened for the winter, so it was possible to get other men familiar with the woods from the ranks of the lumberjacks. They were glad to have a month's work at this time, though it was at labor which they had never done and of which they had never heard.

#### ORGANIZING THE CAMPS.

It is estimated that the cones ought not to cost more than 75 cents a bushel; the harvest was to be 20,000 bushels; therefore \$15,000 was allotted for the work.

The time spent on the reconnoissance of the six Forests, to determine which offered the best opportunities, was well spent, though it deferred the start of the operations so that there was not a great deal of time for organization. The fall rains set in generally by October 15, and the collecting had to start a month earlier. It promised to be a big operation and on a scale never before attempted, so the problem had to be attacked without any helpful precedents. It turned out that the weather continued good well into November.

Headquarters were established in a tent at a strategic center. An emergency telephone was installed to bring operations under closest possible surveillance, and a clerk was hired to keep records and time slips and look after the commissariat.

There were four camps besides the headquarters, and each of the four had its foreman, cook, "cookee," one or more haulers and packers, and about 25 pickers. The men were paid in cash, on a sliding scale, according to the quantity of cones picked.

Each foreman was responsible for the hiring and discharging of the men and for all the work of his camp. Without exception they did excellent work, and though none had ever done any seed collecting they entered heartily into the spirit of the work and handled masterfully the difficult labor situation with which they had to deal. Each picker was designated by number, and all of his work was recorded by that number. At first an effort was made to allot the men to certain areas, but they did not like the plan and, without such allotment, worked without any duplications or disputes. A man turned in a sack full of cones, with his number on the tag it bore; the sacks were checked up at the bins. Since the haulers and the checker at the bins did not know the names of the individuals, there was no chance for favoritism and no object in making false reports to credit one man with another man's pick. If the tallies did not agree the picker was paid by the hauler's report, and when figures were corrected was paid any excess that was due him.

In order to induce the men to stay, they were paid by the day, with a charge for meals if they stayed less than two weeks. For more than two weeks they got their board also. After a short time, during which a fair day's work was ascertained, each man was required to pick 6 sacks (12 bushels) each day to obtain the minimum wage, \$2 per day and board. Fifteen bushels brought \$2.25 a day; 17½ bushels meant \$2.50; and 20 bushels \$2.75.

Notices in five nearest post offices brought the applications for work, and in two days after they were posted the first camp was in full blast. Then the second camp was filled—and overflowed—at once. It was a task to get utensils and supplies; the men had to double up in the tents, and a first and second table had to be established to make the camp dishes go around. Under this arrangement the finest diplomacy was required to keep the cooks, but though the situation was much strained the breaking point was never quite reached. The ranchers' houses were used as additional sleeping quarters, and this increased costs. But the cones kept coming in, and 20,000 bushels was the goal.

#### WORK DONE AT TOP SPEED.

At first the men had much-difficulty in finding the squirrel hoards. When the work started the cones had not yet been cached, but were simply piled on the ground ready for hoarding. But with a little help the men soon learned to look in the likely places, and those who

were instructed soon showed the new ones that it was not the squirrels' cunning but their own lack of observation that kept them from rapidly filling their sacks. There was a natural rivalry to be "high man" each day, and this rivalry was fostered by a bonus; a man was hard put to it to retain the leadership for any length of time. Unsuccessful ones gradually dropped out and those who stayed redoubled their efforts. With about 100 men at work, cones poured in at the rate of more than a thousand bushels a day.

This had some drawbacks. The hauling got behind and sacks gave out. Work was started with 1,700 sacks, quickly augmented by 1,000 more; in the end there were more than 1,000 for each camp, 4,200 in all. The bins, which were constructed for this particular project, could not be built fast enough to take care of the cones. (Pl. LII.) The men began putting in poor cones and skimmed the sacks. Close inspection soon stopped this, however, and on the whole the quality of the cones was high.

One camp lost a half day looking for a "lost man," who had simply left his blankets and gone back to town without them or his pay. Several men actually did get lost, and in some cases were out all night, in spite of persistent searches. This time lost in searching cost \$36.39, or two-tenths of a cent for each bushel of cones; but it was money well invested, because it made the men less timid about striking through unknown woods—they were sure that they wouldn't be left lost very long.

#### THE WORK OF INDIVIDUALS.

There were all sorts and conditions of men, of whom the local ranchers were best. There were lumberjacks, college men, plain "hoboes," barbers, ex-convicts. But they stayed on the job; wages and food were good, and it was a time of slack work in the woods. One crew of five Swedes, lumberjacks, performed marvels. They worked together, and no matter how long the walks or how difficult the country, they gathered, with a regularity that baffled the best efforts of the others, from 14 to 20 bushels each a day. Each was as strong as a mule and equally a stranger to fatigue. Once a great crackling in the underbrush that portended a bunch of grizzlies turned out to be these five Swedes, each with five sacks of cones on his back. The pack horses carried only seven. The cones weighed about 20 pounds to the bushel, and each sack held nearly 2 bushels. Besides being heavy, they were somewhat unhandy. The average pick of these five men was  $17\frac{1}{2}$  bushels a day for each man, and their camp's daily average was nearly 2 bushels more than the average of all the camps. While these men were in a class by themselves, and made the race somewhat hopeless for the others, their influence was of inestimable worth.



WESTERN YELLOW-PINE SEED GATHERED ON THE BLACK HILLS NATIONAL FOREST, SACKED FOR SHIPMENT, CUSTER, S. DAK.

[The sacks contain \$4,300 worth of seed. Cats are indispensable in protecting the seeds from mice.]



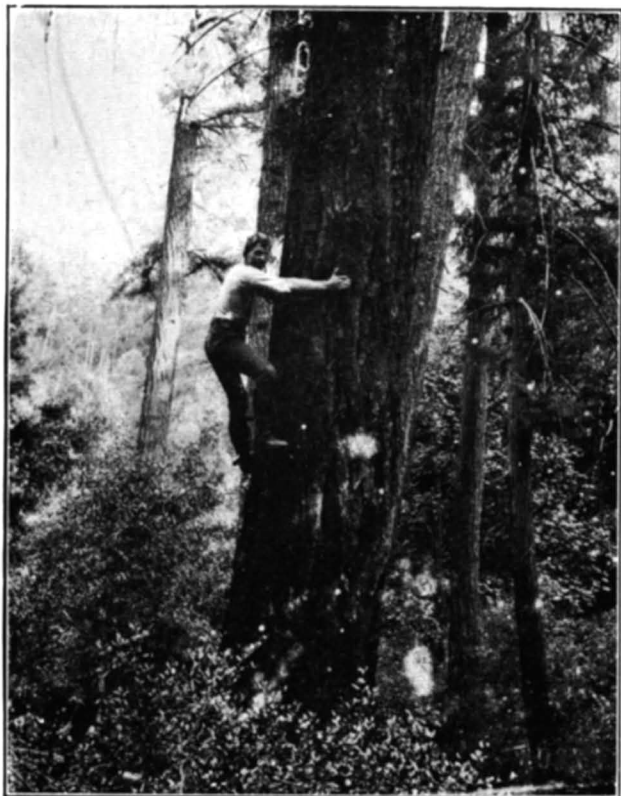

FIG. 1.—A GOVERNMENT FORESTER EQUIPPED WITH LINEMAN'S IRONS, CLIMBING AFTER CONES OF BIGCONE SPRUCE.



FIG. 2.—A SQUIRREL GETTING READY TO CUT OFF CONES OF DOUGLAS FIR, SO THEY WILL DROP TO THE GROUND.

TWO TYPES OF CONE GATHERERS.



FIG. 1.—A SQUIRREL HOARD.

[Only top cones show before the squirrels hide it all under litter. This store contained 10 bushels.]



FIG. 2.—GOVERNMENT PACK TRAIN ON THE KANIKSU NATIONAL FOREST WITH SACKS OF CONES TAKEN UP FROM TRAILS WHERE THEY WERE DEPOSITED.

[They are packed to a wagon road and then hauled by wagon to the storage bins.]



A PARTIALLY UNLOADED WAGON AT THE CONE BINS, SHOWING CONSTRUCTION OF BINS TO INSURE VENTILATION.  
[A boy tallied the sacks by the number of the pickers.]

## SQUIRRELS NOT LEFT DESTITUTE.

The squirrels were by no means left destitute. The country which was picked over was thoroughly covered, but within less than a mile of the stripped areas there were other areas which because of lack of trails or too rough topography were untouched. Then, too, only white-pine cones were gathered, and those of all other species were left for the squirrels. Even in the most closely picked localities there were some caches that the pickers missed, and since the supply was many times greater than the squirrels could use, there was no privation for them. Toward the end the squirrels began to forsake their natural source of supply and learned to hunt for the sacks alongside the road in preference to going to the tree tops. As one old French Canadian put it: "Zee leetle thief; I swipe heem one sack, and heem swipe me two sacks!"

## LESSONS FOR THE FUTURE.

There were some losses of time; there were not enough pack horses and it was impossible to secure more. As a result the sacks stood long enough to be attacked by the squirrels. There should be, in future operations, one man whose sole duty it should be to supervise all the hauling work, which was not under any one of the camps. The teamsters' work would have been lightened and made more effective.

In computing costs the aim was to secure safe, conservative figures. The average quantity of cones per sack was placed at  $1\frac{3}{4}$  bushels, since actual measurements showed that it was somewhat less than 2 bushels. In reducing the figures to unit costs this was the basis.

Item.	Total cost.	Cost per bushel.
Supervision, salaries of forest officers.....	\$850.49	\$0.041
Foremen, in charge of camps.....	354.96	.017
Telephone, temporary construction.....	25.88	.002
Packing sacks, Government pack train.....	120.22	.006
Food supplies and cooking.....	3,000.74	.140
Hauling cones, wages and team hire.....	1,515.62	.071
Picking cones, wages and quarters.....	4,502.95	.210
Office, clerk, supplies.....	142.25	.001
Cone bins.....	671.26	.031
Moving camp.....	120.32	.006
Work in camp, cutting cordwood, etc.....	138.26	.007
Lost men, time spent in search.....	36.39	.002
Repairing roads.....	158.04	.008
Cutting trails.....	52.81	.003
Shipping equipment, bags, etc.....	155.00	.007
Miscellaneous.....	102.86	.005
<b>Total.....</b>	<b>11,948.05</b>	<b>.557</b>

In all, 21,440 bushels were gathered, according to corrected reports. Some cones were lost to the squirrels; in the last few days they worked with surprising rapidity and recaptured, in all, some 350 bushels. Several sacks were lost and were covered with snow before they could be found. All the camps together covered 20,676 acres, which gave an average of 1.04 bushels of cones to the acre.

The costs, which were easily tabulated, came well within the allotted \$15,000, and the quantity of cones exceeded the original estimate by nearly 1,500 bushels. The cost figures are given in the table on page 441.

This made an average cost, for picking alone, of 21 cents a bushel, and about 55.5 cents a bushel counting all costs. This could be reduced on another operation of the same sort in the light of experience gained in this one. The hauling charge might be materially reduced, and a larger equipment of bags, supplies, and tents at the outset would have reduced the costs still more. As it was, the cost was less than half the previous average cost for collecting western white-pine cones.

# IMPROVED METHODS OF HANDLING AND MARKETING COTTON.

By CHARLES J. BRAND,

*Physiologist in Charge of Farmers' Cooperative Cotton Handling and Marketing,  
Bureau of Plant Industry.*

## INTRODUCTION.

One of the most vital subjects before the country to-day is the efficient and economical handling and marketing of the products of the farm. It presents a problem of the first magnitude both from an agricultural and economic standpoint. Upon its correct solution hinges in great part the reduction of the high cost of living. Present systems of distribution of many agricultural products are indirect, wasteful, expensive, and even destructive. In this respect cotton suffers fully as much as any other crop. A complex commercial mechanism has been developed, many elements of which are distinctly not in the interest of the producer, the manufacturer, or the ultimate consumer. It is not too much to say that our present method is susceptible of a great deal of improvement at every step from field to factory. It has been estimated by close students of the question that the present slipshod and wasteful system entails an annual loss to the growers of from \$25,000,000 to \$70,000,000. It is impossible to do more than approximate the total loss, but it is certainly exceedingly large.

It so happens that cotton, the purest known natural form of cellulose, will bear more abuse than any other crop material and still retain a large proportion of its value. It is so stable and enduring that it demands little care and gets less. Corn, because of its perishable nature, demands better treatment and gets it. If our billion-and-a-half-dollar corn crop were treated half as badly it would no doubt shrink in value fully a half billion dollars annually. There are corn cribs on the farm and elevators and warehouses at the railroad stations and primary and secondary markets for the protection of our corn crop. Still, 10 bushels of corn, worth usually at primary market prices only from \$5 to \$6, require as much space for storage as a bale of cotton worth from \$50 to \$60.

## COOPERATIVE ORGANIZATION AMONG COTTON GROWERS.

Cotton planters persist in growing too many varieties in each community, and are careless in many things, including picking and the care of both unginmed and ginned cotton on the farm. Through

lack of thorough cooperation and organized business methods they share with too many middlemen the profits that are rightly theirs. Nevertheless, in a broad sense the individual farmer is absolutely unable, because of the complexity of the system and the industrial character of the crop, to cope with the great problems that exist. Most of the abuses about which spinners, especially foreign spinners, complain against the American farmer arise after he has parted with his cotton and when he no longer has any voice in its treatment. These facts must be clearly recognized, as necessary and permanent reforms can be brought about only by united community action among farmers and by cooperation between growers, ginners, compress men, common carriers, bankers, buyers, spinners, and merchants. In no department of agricultural activity is the formation of growing and marketing associations likely to secure greater advantages than in cotton.

Permanent and necessary improvement can be brought about only when communities handle and market their product as a whole. The same is true as to fundamentally improved conditions in cotton production.<sup>1</sup> The individual farmer can rarely sell a few bales of cotton as advantageously as a community organization could sell uniform lots of 50 or more bales. The individual can not afford to construct the necessary warehouses, nor can he as readily secure needed credit and many other things which organization would bring within his reach.

The California citrus-fruit organizations are handling about 50,000 carloads of fruit per annum. They have established packing houses, cold-storage and precooling plants, and have their own selling agencies all through the United States and in certain foreign ports. Their activities have revolutionized the business of marketing citrus fruits by controlling the supply placed on the market and by avoiding its glutting. They have given the country better fruit without increasing the cost to the consumer, and at the same time have increased their profits. They have also brought about greatly reduced freight rates on their products and more uniform prices have been maintained than would otherwise be possible. Before citrus exchanges were established 15,000 carloads of fruit were being marketed with greater difficulty than are 50,000 at the present time.

The grain-growing farmers of the Northwestern States have organized more than a thousand cooperative elevator companies and handle annually possibly as much as \$250,000,000 worth of grain. A single farmers' elevator company in South Dakota handled over a million bushels of wheat in 1910.

---

<sup>1</sup>A discussion of the benefits that may accrue to cotton communities which will unite in the growing of single varieties and in the adoption of improved methods of breeding appeared in the Yearbook of the Department of Agriculture for 1911 in an article entitled "Cotton Improvement on a Community Basis," by Mr. O. F. Cook.

The cotton growers of the South have the same need, if not a greater need, to organize for the purpose of marketing their product to the best advantage as have the grain and fruit growers. Furthermore, especially in comparison with the fruit growers, the imperishable nature of their product should make handling and marketing problems easier. Something has already been accomplished along the line of cooperation in many localities through the educational work of such organizations as the Farmers' Union, the Grange, the Alliance, and other less widespread movements. Many people are inclined to think that most of these organizations have proved flat failures. This is not true, for even where after a period of years they have become moribund, the educational work they have done has been eminently worth while and will be a factor in bringing the fruits of cooperation home to the cotton farmer.

Many cooperative activities have failed, but some have succeeded. There are several cotton enterprises in the hands of farmers that are being operated with such success as to leave no doubt that others could do the same if they had the same determination and the same willingness to put self aside to some extent for the common good. Farmers are extremely individualistic, and naturally so; hence, the greatest trouble has been not that the farmers were slow to organize, but that they were altogether too willing to fall out with one another when matters did not go to their liking.

At Montgomery, Ala., the farmers have constructed a ginnery and warehouse, and conduct a general store. In marketing cotton they have operated successfully in both domestic and foreign business. Some of the members of the organization haul their seed cotton as far as 20 miles in order to have it ginned and handled through the farmers' company. They have two batteries of four gins each, one of which is connected with a square-bale gin compress. Warehouse facilities are furnished at reasonable rates. Gin-compressed bales are stored the first month free of charge, while flat bales are charged 25 cents per month, with a fairly low rate for the season. Direct connections have been established with Liverpool cotton buyers, and most of their gin-compressed cotton is shipped directly to England.

At Glendora, Miss., a group of planters has its own oil mill, which has been operated at a distinct profit to its membership. In fact, in a market that paid \$17 per ton for the planters' seed they netted about \$22 per ton through carrying out the manufacturing process as far as the crude oil. At Greenwood, Miss., the same group of farmers in part organized a cotton buying and selling company, dealing in about 4,000 bales over and above what they themselves produced. Their profits on this business ran into a number of thousands of dollars.



At Purcell, Okla., there is a cooperative gin and elevator owned by the farmers that has been operated successfully for several years. In this case no marketing of cotton is carried on, but considerable grain is sold for the members of the organization.

The cotton growers of the Imperial Valley, in California, who organized an association less than a year ago, already have accomplished several things of substantial benefit, not only to their own members, but also to those producers of cotton who for various reasons have not joined the organization. Even before they organized they subscribed for more than \$60,000 worth of stock to bring an oil mill and ginnery into the valley. Unfortunately, in a way, their plans were on such a scale and the type of plant erected so expensive that it was necessary to call upon outside capital for additional help; as a consequence, the business, while in the hands of men who show every inclination to further cotton growing in the valley by dealing fairly, is not actually under the control of the growers. Without united action the required equipment could scarcely have been secured.

Early in the season of 1912 the growers organized an exchange, which has made banking arrangements for its members that enable them to secure loans of \$35 per bale on their short and \$60 per bale on their Egyptian cotton at a moderate rate of interest. As soon as the cotton has been ginned the grower places it in the custody of the exchange at the cotton yard. There is less need for warehouses in the desert country than in the humid cotton areas. The cotton is then classed at a fixed charge per bale by a grader secured through the exchange. A certificate is issued to the farmer, upon which, as collateral, the loan is obtained. There is no better security than cotton adequately protected and insured. The loan is enough less than the actual value of the cotton to give no undue encouragement to holding beyond a reasonable time.

The securing of a capable grader who is disinterested, representing neither side of the market, is a distinct service that every organization could perform for its membership.

The Imperial Valley growers also secured by united action the installation of a suitable equipment of roller gins for handling their Egyptian crop. The selling end of their organization has not been tested as yet, but promises to be successful. In case of direct sales to certain mills or to mill buyers the 50 cents commission usually paid to brokers will be paid to the exchange.

The southern California cotton industry is new and comparatively small. In 1911 something less than 10,000 bales were produced. Now excellent arrangements have been made for concentrating the seed cotton. Loading facilities have been provided along the railroads, a reasonable freight rate has been granted, and the seed cot-

ton is to be loaded into cars at the nearest station and shipped to the central ginnery. This system should prove to have many advantages and should also make it possible for the central plant to install facilities for compression at the gin. There is an important point to be considered in every community where an organization is effected. Each grower, whether he joins or not, is benefited in many ways by the existence of a properly conducted association. The burden of costs should not be borne by a few of the beneficiaries. All cotton growers in the territory should join, and they should conduct their business on a partnership and not a competitive basis.

The establishment of an adequate system of agricultural credit would benefit the cotton planter greatly, especially as he progresses in the formation of cooperative cotton handling and marketing organizations.

#### FORMS OF COOPERATIVE ORGANIZATION.

In connection with the cotton handling and marketing work of the Bureau of Plant Industry some study has been made of suitable methods of organization. The laws of very few States provide adequately for cooperative business activities; hence proper care should be taken to insure the legality of any form adopted and, so far as may be found desirable, additional or remedial legislation should be sought. The Wisconsin law is pronounced by experts in cooperation to be admirable and might serve as a basis of legislation in other States. It is, of course, desirable that the laws governing the matter in all of the cotton States be as uniform as possible, as cotton, particularly, is an interstate crop.

The true cooperative plan of organization will probably prove the most satisfactory and effective in the long run. Under this each person has but one vote, regardless of the number of shares held. A reasonable, limited, and uniform rate of interest is paid to all who invest capital in the stock of the cooperative organization. Division of expenses and profits is made purely on the basis of the amount of business done with or through the organization.<sup>1</sup> Satisfactory financial responsibility is absolutely essential to every cooperative organization. Direct or semidirect dealing will be possible only to such extent as the just claims of spinners can be settled promptly and equitably. Where organizations are to act together merely in the growing and handling of their crops, without owning any particular property, gins and the like, the form of organization used so successfully by a number of mutual insurance companies in various parts of the country is suggested. The basic idea of this method, when adapted to cotton, is for the farmer to give the association his note

<sup>1</sup> Those desiring a full discussion of the organization of cooperative associations should consult the article entitled "Cooperation in the Handling and Marketing of Fruit," by G. Harold Powell, in the Yearbook of the Department of Agriculture for 1910, pp. 391-406.

each year for a stated number of dollars per bale of lint or per ton of seed, to bear interest at a certain fixed per cent. The rate of interest and the valuation basis will depend upon the cost of conducting the business of the association. Assuming the assessment rate to be \$10 per bale of lint, the same per ton of seed, and the rate of interest 6 per cent, if a farmer produces and proposes to market through the association 100 bales of cotton and 50 tons of seed, he would make his note to the organization for \$1,500 at 6 per cent. The principal of these notes is not collected and the notes are canceled and returned to the makers at the close of each season. They simply guarantee his responsibility for just claims. To provide for any extraordinary losses that might arise, he would obligate himself in addition for a further assessment of interest, the extent of which would be determined by the board of directors, with the concurrence of a majority vote of the members. The cotton could be bulked and pooled in the seed and ginned to get even running lots, or the bales could be numbered so that in case of complaint against any particular lot adjudication could be made and the individual who furnished that bale would pay the claims against it or the amount involved would be taken from his credit with the association.

Probably in most cases it will pay ultimately for organizations to own their gins, warehouses, seed houses, and possibly oil mills, obligating all members of the organization legally to have their work done at their own ginnery and sold through their own selling agencies. When this is determined upon they should by all means, whenever a good plant can be purchased, buy one already in existence, for it is altogether likely that one of the troubles with the cotton industry at present is that there are too many gins with too low an average output and too high an expense account. Proportionately, it takes much more labor to conduct a one-stand ginnery with an output of 500 bales a year or less than it does one with an output of 1,000 or 1,500 bales a year. There is already a strong tendency toward a reduction in the number of active gins. The census figures show that between 1906 and 1911 the number of gins was reduced by more than 2,000—from more than 28,000 to about 26,000.

#### IMPROVED HANDLING OF COTTON ON THE FARM.

Work in two distinct directions is needed in cotton. The first should aim at the ultimate attainment of a general cooperative system of growing, handling, and marketing the crop. The other should have for its purpose the improvement of present methods in every possible way. No amount of work along either line will greatly lessen the need of all possible development along the other. The changes in present methods, discussed later, are all desirable under any conditions, and can be brought about most readily in

those sections where the development of community action has made the greatest progress.

There are many changes needed which the farmer alone can not bring about; others are within his own reach. Cotton should be accorded, to the required degree, the same good treatment that is given corn. Seed-cotton storage houses should be built, holding from 5 to 25 bales or more, according to the needs of the individual farmer. Facilities should be provided so that cotton after it is picked can be placed in these houses and left from two to five weeks. The desirability of this procedure is urged more especially on growers of staple varieties. The farm storage of seed cotton will benefit both the cotton and the farmer in a number of ways. In the first place, it is the consensus of opinion that the luster and strength of the lint is improved measurably. In some experiments conducted by the Office of Cotton Standardization, in the Bureau of Plant Industry, an increase of several per cent in strength was noted in the case of cotton stored in the seed as compared with the same growth of cotton ginned immediately. That the luster of the fiber is improved by a sweating-out process is not surprising, and it is possible that both of these beneficial results may be due to the slight diffusion of the oil in the seed through the mass of the cotton. Still another benefit accruing through the storage of seed cotton on the farm is a reduction in the amount of time now wasted by men and teams in hauling the seed cotton to the ginnery and standing in line awaiting their turn. It is true that commonly the least valuable boy or man drives the team. Nevertheless, the time spent standing at the gin in many parts of the country represents a very heavy item of cost chargeable to the bale. With seed-cotton storage houses in common use much of this could be obviated. Another important benefit would be secured in maintaining the uniformity of the individual farmer's cotton. As ginning is done at present, a farmer with a low-grade bale may precede one with a high-grade bale at the gin, or a farmer with a three-fourths staple may stand just ahead of one with an inch and an eighth staple. The gin is rarely thoroughly cleaned out, with the result that the farmer who grew the better grade or staple gets a plate of poorer cotton, varying from a few to 20 pounds in weight, on his better bale. As a result of this careless method the buyer, sampling both sides of the bale, calls it a "mixed" bale and refuses to pay what it is really worth. Cases like this result in great injustice to the growers of better grade and longer staple cotton, and in the course of a season in the country at large cause much loss to the very class of cotton growers who deserve the greatest consideration. Another benefit that would appear under this method is that farmers producing from 50 bales upward may thereby produce commercial lots of even-running cot-

ton, which they should be able to market to much better advantage than the odd lots which the present system forces them to offer.

Many ginners who buy cotton in the seed claim that a higher yield of lint is secured after storage, owing to cleaner ginning from the seed. It is possible that the ripening or curing out that takes place in storage causes the fiber to loosen from the seed more readily.

Another great benefit from storing seed cotton on the farm and then having it ginned in quantity is that it will more readily enable each individual farmer to keep his seed pure. Under the present system the same difficulties exist in keeping seed pure as in preventing "plated" bales. The conveyors and feed roll are not completely cleaned out and the last of one farmer's seed is mixed with the first of the next farmer's. This is of great importance to all farmers who are growing staple varieties in short-staple districts. It is difficult and sometimes almost impossible for the ginner to clean out his machines completely after each load of cotton. The loss of time would constitute a heavy charge against his outfit and probably reduce the number of bales which he could turn out in a day. In case of stored cotton this would partly be compensated for by the fact that it can be ginned at a higher speed without gin cutting or other injury than can newly picked cotton.

Another benefit that would accrue is the even distribution of moisture through the mass of seed cotton in the farm storehouse. When the pickings of the morning are thrown upon the drier pickings of the previous afternoon the excess moisture will distribute itself evenly and not be a menace to the ginning quality of the fiber. Cotton with any noticeable degree of moisture should, of course, be dried to some extent before it is put in the storage house.

In an experiment in South Carolina in the season of 1912, 40,000 pounds of thoroughly ripe seed cotton were stored in a single body for several weeks without "heating" in the least. Early-season pickings are most likely to heat. They should be watched carefully and either ginned immediately or forked over.

Farmers should begin at once a far more general practice of sheltering properly all bales retained on the farm. Platforms with galvanized roofs can be constructed at small expense, and much country damage, which in the aggregate is a great drain on the industry, can be obviated. Furthermore, such shelters will enable the grower who can afford to do so to hold his cotton without wasting fiber or danger of injury to its spinning value. A respectable appearance of the bale could also be maintained. It is a noticeable fact that in the cotton country, generally, bales are left exposed to all sorts of untoward conditions, but that spinners have substantial brick warehouses for the protection of the staple. Plate LIII, figure 1, shows the condition in which bales often reach the railroad platform.

## THE HOLDING OF COTTON BY FARMERS. \*

Discussion of facilities for protecting the fiber from injury on the farm naturally brings up the general question of the holding of cotton by farmers. Any form of storage, whether in the seed or after ginning, should tend to do away with the present sharp drop in the price of cotton which usually begins late in September and continues until November. Having no adequate means of storage and being usually in need of money, the farmer rushes into the market as soon as cotton-picking time arrives and acts as the greatest bear on his own product. Ordinarily, by the middle of November from two-thirds to three-quarters of the crop has been ginned and the greater part of this has passed to the hands of middlemen and spinners. In other words, under present conditions as soon as ownership of the major portion of the crop passes from the farmer the price begins to rise. It is impossible, even after a careful study of the statistical movement of prices from month to month for a period of years, to say definitely to what extent "holding" is a paying venture under present conditions. The average gain in prices in the leading Upland markets during the last 15 years indicates that October and November ginnings might be expected to increase in value about  $5\frac{1}{2}$  per cent if held for 6 months. Taking into account insurance and other costs, including loss of interest on the money tied up in cotton and the fact that the farmer's money comes high when he borrows it unsecured by real estate, it seems that the profits of holding cotton, while decidedly worth while, would not be excessively large. The whole question of holding must necessarily depend upon the cost of production to the farmer as compared to the price offered. Each farmer should determine this cost as accurately as possible for his individual conditions. Only in this way can the question of holding be settled. If it costs a farmer 8 or 10 cents per pound to produce his cotton he can far better afford to hold it, provided suitable warehouse facilities are available, than can any middleman or spinner who pays 10 or 12 cents per pound for the same cotton. This general fact is modified, of course, by the prevailing rate of interest paid by the two classes of holders.

Holding merely for the purpose of raising the price when the prevailing price is fair and when the supply is ample and equal to the demand is bad economics and probably wholly indefensible. Any widespread movement to bring about excessively high or fixed prices will certainly result in the stimulation of cotton culture in foreign countries and the ultimate restriction of the market for American cotton. Storing in the seed, holding to secure a fair price considering the cost of production, or any other methods that tend to stabilize the price or improve the quality of the staple are desirable and proper and should be practiced by all who can afford to do so. It is

good economics to hold over the surplus of a year of big production to another year of lesser production. This is done at present by those into whose hands the cotton passes on leaving the farmer. In June, 1911, when the farmer no longer had cotton to sell "middling" brought about 15½ cents; in the previous November, when the farmer was selling his crop, the average farm price was reported as 14 cents per pound.

#### MORE CAREFUL GINNING.

Cotton often reaches the mills badly gin cut. This reduces the value to the spinner and may result in claims and losses and attendant expenses, especially if the cotton has gone into the export trade. Such injury is probably most common when long-staple cotton is ginned with the ordinary saw-gin installation at the usual high speed. Eagerness to utilize fully the capacity of all machines is natural, and for the most part commendable, but it should be remembered that increased output will not represent any real gain if the fiber has been injured. When longer staple cottons are ginned with saw gins lower speeds and looser gin rolls should be employed, and the longest staple cottons should probably always be ginned with special gins. This bad practice rests largely with the ginner himself, as do many others. Nevertheless, there center at the gin other bad practices for which the ginner is in no wise responsible and which must be brought home to the farmer. Perhaps the worst of these is the delivery of cotton for ginning which is too damp to gin properly. If morning finds the cotton damp it should be properly dried out before it is offered to the ginner. The sale of morning dew as cotton is very likely to injure the staple and reduce the value of the bale.

A second prolific source of complaint at the gin is due to an excess of various kinds of dirt in the cotton. A great deal of sand and earth is considered perfectly legitimate in cotton. It is regrettable that this is the case, as the grade of the cotton and hence the price given for it will always depend to some extent upon the presence of this waste. There are farmers who object to cleaning attachments and cleaner feeders because they remove sand and dirt, which they would otherwise hope to sell as cotton or cotton seed. However, in fairness it should be said that while individual farmers indulge in a few bad practices the farming community is by far the greatest sufferer in our present wasteful system of handling and marketing the cotton crop. It happens altogether too often that a man who goes to a gin that has the proper equipment of cleaners receives no more for his lint than his neighbor who goes to an outfit where cleaners are not in fashion and where sand and dirt go in part into the bale and in part into the seed. It is very rarely indeed that the farmer who exercises great care in producing and picking his cotton receives the consideration that the better quality of his product deserves. The

present system puts a premium on carelessness. In some markets, even during the season when the highest class of staple is being harvested, no grade above "strict middling" is recognized.

Ginners frequently allow their plants to get out of repair, defective saws and worn-out brushes are used, and the speed of the brush is not properly regulated. A complete modern gin plant is shown in Plate LIII, figure 2. In the eastern and older part of the cotton belt especially, out-of-date types of machinery are still in general use. Many improvements in the way of feeders, cleaners, huller breasts, condensers, and the like have been devised in recent years. Their use is recommended, and farmers should give their business to the ginner who is most progressive in giving his patrons the advantage of modern equipment and the better style of cotton that results.

Gin press boxes are made in different sizes by different manufacturers. After being used for a time all boxes expand in varying degrees, depending on construction and kind of usage. This adds to the lack of uniformity that has resulted already from the great variation in the quantity of cotton put in bales. The standardization of gin boxes is exceedingly desirable. State departments of agriculture could advantageously have one or two competent gin inspectors on their staffs, who could investigate equipments and suggest needed changes and improvements. In addition, the farmer must educate himself, and be educated as to what constitutes satisfactory ginning.

#### THE INADVISABILITY OF SELLING COTTON IN THE SEED.

Selling cotton in the seed is a sort of game of chance based on the law of averages and should be discouraged. The practice is confined almost exclusively to the western end of the cotton belt. The better class of buyers base their calculations of lint percentages in making their offers for cotton on the comparative yield from day to day of lint to seed in their own gin or the one which they patronize. As a result the farmer who grows a better variety yielding a higher percentage of lint gets only the average price; the one who grows a "sorry" variety will in most cases receive some of the benefits that belong to his more progressive neighbor. Oil-mill ginners are most likely to urge this method of selling upon farmers, but the better class are willing to help terminate the practice, and some of them are already taking steps toward educating the farmer to a more universal practice of having cotton custom ginned.

#### NEED OF A WAREHOUSE SYSTEM IN HANDLING AND MARKETING COTTON.

The most important step to be taken in the direction of permanent improvement in cotton-marketing conditions is the establishment of a general warehouse system, and the gradual marketing of the crop. Farm storage of ginned cotton as at present practiced is in large



part wholly undesirable. It means leaving the bales out in the weather, sometimes on platforms or boards, but often also flat on the ground. This way of "storing" is the most prolific source of country damage, and occasions a large waste in the industry. Farmers who can afford to hold their cotton without facilities for obtaining loans on it should construct suitable shelters and thus save the cost of warehousing. The cooperative organizations which must be formed before we can go far with improvement work should build gin or primary market warehouses, properly located and equipped for economical handling to cars. Concrete platforms with galvanized iron roofs can be constructed at reasonable cost in most sections. They will be fireproof to a great extent and will usually furnish desired protection from country damage and deterioration.

The warehouse alone is not sufficient. Growers must have the interest and support of their local banks in a far greater measure than is now the case. Negotiable warehouse receipts, covering adequately insured cotton that has been graded, stapled, and properly certified, should command their confidence and furnish a tangible opportunity for cooperation between the producer and banker. The latter craves active accounts, the frequent "turning over" of money, collections, exchange, and other revenue-producing forms of banking activity. The interior buyer's account has a greater earning capacity for the bank than has the farmer's; hence its preference. A uniform and efficient warehouse system would not reduce the amount of banking business in the interior, but would spread it over a longer period. Neither would it prevent legitimate middlemen handling the crop, as their functions are necessary and must be performed by some one. The support of the banking interests could be so handled as to attract a large short-time loan business to insured warehouse cotton at reasonable rates. Southern bankers handling cotton accounts can do more for the cotton industry than almost any other element.

From the cooperative standpoint, the warehouse is a necessity for concentration purposes. Here the cotton can be graded while still in the farmer's ownership, and sold at its intrinsic value. Even-running commercial lots, such as the market demands, can be made up and many other advantages realized.

The adoption of a uniform and comprehensive code of laws on the subject of warehouses by the cotton States would do much to assist in a more rational marketing of the crop. There are no accurate statistics covering the point, but it is probably true that available warehouse space would not accommodate more than one-sixth of the crop. This is too low a proportion to have any marked effect in bringing about the gradual marketing that is desired.

The present system has developed largely on the theory that even-running lots of cotton can be secured only by having large concen-

tration points. Concentration is largely synonymous with congestion and delay. The need for it can be removed in considerable part by the installation of better types of cleaning and ginning systems, bulking or pooling seed cotton in certain classes, and the inauguration of means of compressing it at the gin and warehouse.

#### THE NEED OF STANDARDS AND GRADING.

Standards for the proper classification of cotton are, of course, a necessity. In accordance with an act of Congress, official grades were established by the Department of Agriculture in 1909.<sup>1</sup> Although these have been distributed quite widely and have been adopted by a number of exchanges and other cotton organizations, some influential bodies have taken no action on them as yet. Their adoption is purely voluntary. To secure the benefits that the prevalence of one uniform standard for all commercial grades should confer, a unanimous adoption is most desirable. Several different standards are now in use. These are usually referred to by the names of the exchanges which promulgate them, as Liverpool grades, New York grades, Augusta grades, etc. The "middling" of one market is not the same as that of another, and likewise with other grades. Identical names are applied in different markets to cotton that differs in quality, value, and price. The national standards were prepared to remedy this condition. Nine official grades are recognized, as follows: Middling fair, strict good middling, good middling, strict middling, middling, strict low middling, low middling, strict good ordinary, and good ordinary. The grades designated by the prefix "strict" are known in the trade as half grades.

At present the fine distinctions that are drawn between grades arise not when the farmer is disposing of his staple to the first buyer, but in arbitrations between buyers and between buyers and spinners. In other words, the benefits of proper classification are largely lost to the farmer, a condition which deserves correction. He usually gets the basis "middling" price minus charges to port, deductions for tare, and the like. For his best cotton he may get "strict middling," but rarely anything higher. Experience soon gives the buyer a knowledge of grade and staple, which the grower can never acquire in equal detail. The latter is practically compelled to sell his product on a quality basis specified by the person who is purchasing it. The farmer must either know more about grade and staple, or he, collectively as a community, must have some one in his employ who will put him in a position to trade as other people trade in their products. Country buyers are frequently almost as ignorant of

<sup>1</sup>The national standards have been prepared and distributed under the direction of Dr. N. A. Cobb, agricultural technologist, Bureau of Plant Industry, to whom communications with reference to them should be addressed.

grades as planters; hence they "buy safe" to protect themselves. A wide dissemination of knowledge as to grades and grading is necessary. The official grades based on the national standards should be more widely used in the United States; if possible, their adoption by all the more important foreign exchanges also should be secured.

#### BETTER COMPRESSING AND THE INTRODUCTION OF THE GIN COMPRESS.

Under the present system the gin-box, plantation, flat, or uncompressed bale, as it is variously called, has a density of about 11 or 12 pounds per cubic foot. Its usual dimensions are 54 by 27 by 45 inches. An average of 25 flat bales are loaded in cars of ordinary size and shipped to the nearest compress, usually known as a recompress or railroad compress. (See Pl. LIV, fig. 1.) As the usual commercial lot is 100 bales, four cars may be required for the haul. The compress collects its fee for service, amounting usually to 10 cents per hundred pounds of cotton or 50 cents per bale, direct from the railroad company, the latter having included this charge in its freight rate. The producer pays this, as well as insurance, freight, and other charges, all of which are deducted before the price is fixed.

On arrival at the compress platform, which often has insufficient roof to protect more than a small proportion of the cotton on hand, the hundred bales are unloaded, weighed, put on range (that is, lined up side by side with faces out), and sampled. They are now classed, compressed, and patched while in the press, and then are ready for reloading for shipment to port or domestic mill. Compressed bales in good average condition are shown in Plate LIV, figure 2. Compression reduces their thickness one-half or more, bringing them to a density of 22 pounds per cubic foot. Two cars will now accommodate the hundred-bale lot.

Compresses ordinarily employ low-priced labor, and are under pressure to show a large output of bales during the time they are in operation. In the Southeast their earnings must be ample, as the average number of bales handled is relatively large. Georgia, for instance, with a crop averaging 2,000,000 bales annually, has only 35 compresses. Oklahoma has about 36 compresses, with a crop averaging about three-fourths of a million bales.

Although the bad condition of many bales delivered to the compresses furnishes some extenuation, the quality of the work is in many cases unnecessarily poor, because of overcrowding and carelessness. That it can be improved is shown by the better average condition of bales this year, brought about by the new rules of the South Atlantic and Gulf steamship carriers.

Pressure by carriers, legislation, and systematic compress inspection could vastly improve existing conditions. However, no amount of betterment in the present method of handling the crop should be

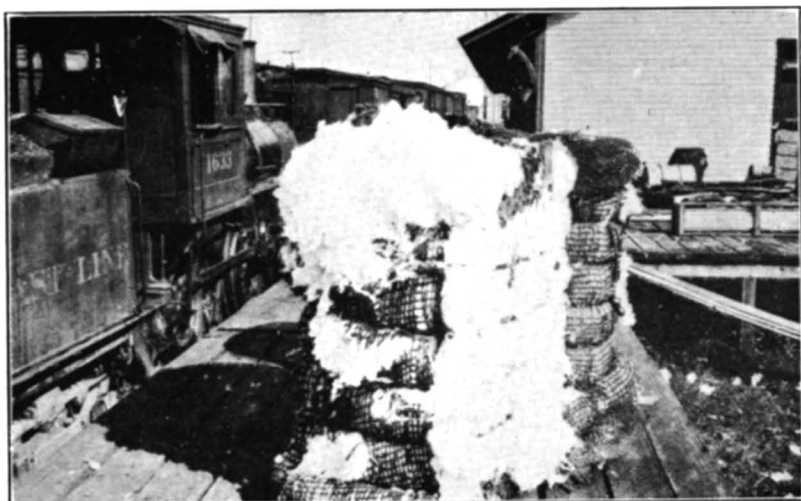

FIG. 1.—ORDINARY FLAT BALE OF COTTON AS IT FREQUENTLY APPEARS AFTER SAMPLING AND ROUGH HANDLING. IT INVITES FIRE, COUNTRY DAMAGE, AND ROBBERY.



FIG. 2.—TYPICAL COMMERCIAL GIN PLANT IN SOUTHERN TEXAS, SHOWING OCTAGONAL STORAGE HOUSE FOR SEED COTTON, WITH MODERN SYSTEM OF PNEUMATIC UNLOADING AND CONVEYING PIPES.



FIG. 1.—RAILROAD COMPRESS AT SHREVEPORT, LA., SHOWING COTTON BALES ON END IN FOREGROUND AND PLACED "ON RANGE" FOR SAMPLING ON PLATFORM.

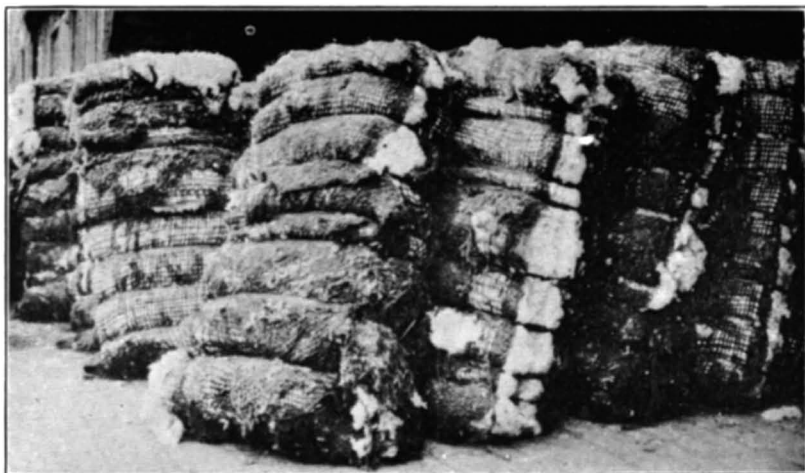

FIG. 2.—ORDINARY COMPRESSED COTTON BALES READY FOR EXPORT, SHOWING PATCHES OF COARSE BAGGING BOUND ON TO COVER SAMPLE HOLES AND TO INCREASE TARE.



FIG. 1.—THE ROUND COTTON BALE, WHICH IS PUT UP AT THE GIN WITH A DENSITY GREATER THAN THAT OF THE COMPRESSED BALE. IT IS ABOUT 3 FEET LONG BY 20 INCHES IN DIAMETER, WEIGHS ABOUT 250 POUNDS, CARRIES 1 PER CENT TARE, AND CAN BE SHIPPED DIRECT FROM GINNERY TO MILL.



FIG. 2.—GIN-COMPRESSED SQUARE COTTON BALES, COMPLETELY COVERED, HAVING A GREATER DENSITY THAN ORDINARY COMPRESSED BALES AND CARRYING LESS THAN HALF THE TARE. THOSE SHOWN ARE FOR SHIPMENT DIRECT FROM GIN PLATFORM TO BREMEN, GERMANY.



FIG. 1.—FARMERS' COTTON BALES IN DILAPIDATED CONDITION, FOR WHICH THE FARMER IS NOT RESPONSIBLE, DUE CHIEFLY TO THE USE OF SECOND-HAND BAGGING BY THE GINNER, A CONDITION MORE PREVALENT IN THE EAST THAN IN THE WEST.



FIG. 2.—FARMERS' COTTON BALES PRODUCED BY THE BEST CUSTOM GINNERIES, SYMMETRICAL AND COVERED WITH NEW BAGGING, ALTHOUGH THE LATTER IS VERY COARSE AND HEAVY.

allowed to prevent the gradual introduction of gin compression in all communities where conditions are suitable. As gins make replacements of out-of-date and worn-out equipment, one of the several proved types of gin compresses should be installed with the new system of gins. Under prevailing conditions it seems probable that gin plants with an output of less than 1,500 bales can not afford to put in square-bale compresses, while the round-bale press may be used to advantage. The character of bales produced by a round-bale gin compress is shown in Plate LV, figure 1. The ever-increasing world's consumption of cotton makes it likely that a gradual change to a new basis can be made with little or no actual money loss, even to the old-line compresses. There will always be competition for the business, and a large number of cotton ginneries will never be able, because of their small output, to use the gin compress.

As already pointed out, the use of six ordinary freight cars is involved in moving 100 plantation bales from the primary market to port or mill. The completion of the bale in final form at the gin would reduce this number to two, or, by the use of one of the slightly larger cars, to one. This means a great saving of rolling stock, motive power, labor, and time. Such reductions in transportation expenses should call for a measurably corresponding reduction in transportation charges. These have not yet been granted by the carriers. In fact, in the eastern part of the cotton belt the compress fees are not remitted. As a broad matter of policy it will work to the ultimate advantage of the carriers to encourage the introduction of all improvements in the cotton industry that make for economic efficiency. In the West the railroads deduct these fees from their freight charges when either round or square bale gin-compressed cotton is offered for shipment.

Formerly there was some prejudice against round-bale cotton, which is put up in 250-pound bales. The ground for this has apparently been removed, and now it is taken freely by foreign spinners. There has never been any great criticism of the square gin-compressed bale, which is similar to but much better than the present recompressed bale. Gin-compressed square bales are shown on the platform ready for shipment in Plate LV, figure 2. When covered with burlap or other closely woven material they resemble bales of cotton goods. The density of these bales ranges from 28 to 35 pounds per cubic foot, against 12 pounds for the plantation and 22 pounds for the railroad-compress bale. There are several types of both square and round bale gin compresses on which thousands of bales are made yearly. Hence, their practical operation is no longer open to question. The prices at which the square ones are offered stand in the way of their general adoption. Round presses are handled mostly on a lease basis, to which frequent objection is heard.



Gin compression has many advantages which can not be touched upon in the confines of a Yearbook article. A comparison of the farmers' bales as delivered to a railroad platform in South Carolina, shown in Plate LVI, figure 1, with the gin-compressed bales on the plantation, shown in Plate LV, figure 2, summarizes the difference in results under the two methods. The gin-compressed bale as now handled is not ragged, has no sample holes and no patches; is completely covered, and is sold on net weight, doing away with the vicious 6 per cent tare provision under which exporting is done at present. It commands a lower insurance rate, economizes warehouse space, and is shown preference in ocean shippers' rates.

#### PRESENT TARE PRACTICES AND THE STANDARDIZATION OF TARE.

The character of the American cotton bale, both as to condition and covering, has been a source of complaint and criticism for many years. The blame is quite generally laid at the farmer's door. He in reality is merely the victim of an out-of-date, incorrect, and oppressive method of arriving at the net weight of cotton in a bale. The buyer, whether for domestic or foreign trade, does not pay cotton prices for the bagging and ties placed on bales at the gin, although many farmers are of that opinion. Southern mills using locally produced cotton usually buy it flat (i. e., uncompressed) on a tare basis of 22 pounds per bale. New England mills allow 24 pounds for tare, while practically all export cotton is sold on Liverpool terms of "c. i. f. and 6 per cent," which means a deduction of 30 pounds for every 500-pound bale.<sup>1</sup>

Allowance for tare always is figured in some form in the price offered to farmers for their cotton. In other words, a 500-pound bale is considered as containing 470 pounds of cotton. If the "middling" price in Liverpool is 12 cents, the bale is worth not \$60 but \$56.40. As the buyer purchases on a gross-weight basis he must protect himself against the tare rule; hence his offer to the farmer, profit and other items of expense having already been reckoned in, is \$56.40 divided by 500 pounds, or 11.28 cents per pound. The above represents the logical working out of the terms of the contract. As a matter of fact, in a majority of cases the actual method of applying the rule to cotton suspected of being overtared does not coincide with the stated terms. Instead of weighing the bagging and ties and determining whether they amount to more than 6 per cent of the gross weight, an arbitrary allowance of 9 pounds for bands and  $3\frac{1}{8}$  per cent of the remaining 491 pounds for bagging is substituted.

<sup>1</sup> The provision "c. i. f. and 6 per cent," referring to the contract form under which American cotton is sold in Liverpool, means that the seller bears all costs, including land and marine insurance and interior and ocean freight, and accepts a deduction of 6 per cent for tare. A detailed discussion of this subject may be found in a bulletin entitled "Cotton Tare," issued Sept. 3, 1912, by the Bureau of Corporations, Department of Commerce and Labor.

The latter amounts to  $17\frac{1}{2}$  pounds, so that the actual allowance for tare is only  $26\frac{1}{2}$  pounds, instead of 30. Although much cotton is now handled under terms that modify the 6 per cent clause, this anomalous condition results in gross injustice to the American shipper. Immediate steps should be taken to correct it.

The effect of the whole tare situation is vicious. Its net result is to introduce complications and confusion in all cotton transactions from planter to spinner. The farmer rarely knows whether his fleecy staple is destined for foreign or domestic sale, and, if the latter, whether it will go to New England or to some of the many southern cotton mills. In other words, he does not know whether he should put on 22, 24, or 30 pounds of tare. As a matter of fact, he practically always puts on the same amount of bagging and ties, weighing usually from 19 to 22 pounds. If he attempts to "tare it up" he is met by a notice from the large cotton-buying firms that operate in his section or from mill buyers if in southern mill sections, that they will not purchase cotton that carries more than the usual amount of bagging and ties (6 yards of bagging and 6 ties), or if they do buy his bales they will be penalized in the price paid.

In the interest of good, straightforward business and for the protection of farmer, cotton merchant, and spinner the present diversity in assessing tare and in making tare calculations should be terminated. The economic waste involved in the purchase of millions of pounds of extra canvas, on which freight and handling charges must be paid, should be stopped. The reason or excuse for using old bagging and for plastering cotton bales with old fertilizer sacks and similar fabrics in order to bring the tare up to the limit of protection which the contract calls for should be removed. These and many other reforms could be brought about much more readily if compression at the gin were put into general practice. The use of old bagging is more prevalent in the East than in the West. The common result is shown in Plate LVI, figure 1. Plate LVI, figure 2, shows the best type of gin or plantation bale covered with new jute bagging.

The present gin-box bale, after frequent and often very wasteful sampling, must be recompressed and the sample holes patched. Slashing bales completely across the front and back is unnecessary. Some universal rules in the matter of sampling should be adopted, to cover the length and location of the cut and possibly also to limit in a measure the number of holes permissible. It should also be practicable to devise automatic sampling mechanisms that would be both dishonesty proof and "fool proof" and could be attached to gins, thus doing away with the need of much later cutting. Sampling abuses, with their attendant pickings and city crop, do not amount to much in individual cases, but in the aggregate result in a large and partly preventable waste. The most likely cure for the

tare troubles of the present system lies in the use of more closely woven and probably lighter bagging, preferably a burlap, such as is used on the Egyptian bale, and the buying and selling of cotton on net weight. The covering should be made in patterns of standard size and weight, standard patches should be adopted, and a fixed number of ties of standard weight and length should be used. There are practical difficulties in the way of all changes and even the most beneficent reforms encounter strong opposition. It is believed that the greater part of the cotton industry is ready to assist in any sane and practical changes that will put cotton transactions on a net-weight basis. Experiments are in progress on the standardization of tare. The needed reforms should be brought about by mutual consent of all parties. Failing in this, legislation might be resorted to.

There are students of cotton economics who profess to believe that general net-weight buying will result in the bale becoming wholly uncovered. In other words, that the tare rules are the only reason why the planters put bagging on the bales. The writer's observations throughout the cotton belt discredit this opinion. Even if it were true, the penalization which is so effective at present to prevent overtaring would be just as useful to compel proper wrapping.

#### IRREGULARITIES IN WEIGHING.

Complaint is heard so frequently of the weights declared by compresses, public weighers, and some warehouses as to force the conclusion that "there must be some fire where there is so much smoke." Most of the cotton States have adequate laws covering weights and measures and properly constituted officers charged with their enforcement. More thoroughgoing inspection and checking up are all that is needed in such States. Other States, among which Texas is most notable, as she produces practically one-third of the American cotton crop, do not have laws or proper administrative machinery for the protection of seller and buyer. The enactment of uniform laws and their just enforcement are highly desirable.

The writer recently purchased for experimental purposes three bales of staple cotton.

	Pounds.
The planter's weight was.....	1, 756
The public weigher's weight was.....	1, 732
The storage-house weight was.....	1, 760

The reason for this variation has not yet been determined. Similar experiences occur in many places. "Safe" weighing to protect buyers appears to be more or less of an institution in the cotton trade. It is usually excused on the ground of variable moisture content and loss of moisture and is indefensible.

## MOISTURE IN COTTON.

The issue of moisture in cotton has not yet been squarely met anywhere. There is some complaint abroad that American cotton contains an excess of moisture. In regard to this it can be said with absolute truth that except in very rare cases of individual dishonesty no artificial dampness is added intentionally to American cotton. So-called "water-packed" bales are due chiefly to leaking pistons resulting from equipment that is out of date or in disrepair.

Cotton changes hands so many times, claims for underweight are made so regularly by both domestic and foreign purchasers, and farmers are penalized so promptly in the price paid them if excess moisture is at all apparent that there is little tendency toward intentional dampening at the gin. In both Egypt and India, on the other hand, humidifying is practiced quite openly and defended as proper and in part necessary. The whole subject deserves careful investigation and subsequent action based on actual findings.

## CONCLUSION.

The conclusion seems warranted that the most desirable and far-reaching reforms and improvements must be based upon changes in ginning practice and must involve laying an increased responsibility upon the ginner.

"Water-packed" and "plated" bales are wholly preventable, and it should be a misdemeanor to produce such a package. The ginner should also be liable in damages to the owner of the cotton thus injured. Gin-cut cotton results either from operating defective equipment, which competent gin inspection could remedy or condemn, or from ginning cotton when too damp. The ginner can readily detect the latter condition and should not be permitted to gin wet cotton even at the request of a valued customer. As a matter of fact most of the wet cotton offered is "rent cotton," or cotton already pledged as the sole security for debts and in the quality of which the grower no longer feels an interest. In such cases the interests of the creditor are entitled to legal protection at the gin. Uniformity in size of bale and in style and quality of covering can come only through the unanimous action of ginner by agreement or by legal requirement. Samples taken at the gin and protected by suitable regulations can be made a satisfactory basis for determining grade and staple and will remove the necessity of cutting the bale for sampling in primary markets.

Coupled with a proper grading system the ginner's sample would be made to furnish an acceptable basis for every necessary transaction between producing and consuming organizations, eliminating the cutting and consequent robbing and deterioration of bales, obvi-

ating the patching and resultant changes in tare at compress points, removing the most common grounds for claims, and reducing to a minimum the city crop, which is a needless tax on the industry.

Through the gin the entire crop must pass and at that point the cotton first comes within the reach of official or trade regulation. From the gins can come the only conclusive statistics of the crop. Through the ginner alone can the careless, ignorant, or dishonest producer be effectively reached. The gin plant is, in short, the vital point in the cotton-handling situation and offers an effective agency through which to bring about improved conditions. Well-organized, responsible cooperative growing and handling associations, acting in concert with the other elements of cotton trade, can ultimately bring about improvements that will save millions of dollars.

## DAIRYING AND ITS RELATION TO AGRICULTURE IN SEMIARID SECTIONS.

By A. K. RISSER,

*Senior Dairyman, Dairy Division, Bureau of Animal Industry.*

### DRY-LAND FARMING.

Agriculture in the semiarid sections, or dry farming as it is generally called, in its early development was devoted almost exclusively to the production of crops. A doubting public had to be convinced of the possibilities of this group of lands. So all thought and energy was concentrated on the important subjects of tillage, conservation of moisture, cropping systems, and the discovery, breeding, and selection of drought-resistant plants. So much attention has been given to the growing of wheat on the dry-land farm that, in the minds of many, dry farming is synonymous with cereal production.

The pioneer work of demonstrating that crops can actually be successfully grown on these semiarid lands has been well done. So well, indeed, that few desirable locations remain to be homesteaded. The problem now presenting itself, and it is a serious one, is how to make this dry-land farming a permanent and enduring agriculture.

### CEREAL PRODUCTION.

The present practice of exclusive grain growing is leading to sure failure. History fails to record an instance where a soil was so fertile that it could indefinitely support a one-crop system. The soil of the semiarid lands is quite fertile in mineral plant food, but is deficient in humus, and so is ill fitted in the first place to support continuous cropping to wheat. Frequently a decline in yield can be noted in the third crop following sod.

The weakness of dry farming lies in the fact that too little attention is given to maintenance of fertility. Before we can legitimately consider these semiarid lands a permanent addition to the agricultural area of our country the present one-crop system must yield to a system of handling which will restore to the soil most of the fertility that is removed in the harvested crop. In addition to this restoration the supply of humus must be augmented. No system of agriculture, dry farming included, can hope to survive under methods which gradually but surely are impoverishing the soil.

## IMPROVEMENT OF THE SOIL.

One way to supply humus to a soil is to plow under green crops, particularly legumes, such as clover and alfalfa, but this is not economical, even in humid sections, and on the dry-land farm is not generally possible. One of the very best as well as most profitable ways to maintain fertility is to feed the bulk of the crops to live stock on the farm and apply the manure to the field. It seems a fundamental principle that for the highest development of either farming or stock growing they must be carried on together. The experience of the dry-farm settler, and the results of investigation as well, indicate that successful dry farming needs the cooperation of live stock. Such cooperation will insure the permanence of dry farming.

As to the kind of live stock to be used, that depends upon the preferences of the farmer, adaptability to locality, and the markets. In the semiarid section of the Great Plains dairying is becoming popular and is being urged by the various experiment stations. Its rapid development is due to several things, but chief among them is the fact that it provides a reliable income.

## WHEAT RAISING UNSUCCESSFUL.

A strenuous effort is being made on the Plains to establish permanent farm homes. The prospect that prompted the early settlers to plow up the range was the hope of quick wealth growing wheat. But it has been demonstrated that wheat growing is a failure about two seasons out of five. Some sections of eastern Colorado and western Kansas and Nebraska have been settled as many as three distinct times. The proceeds of many valuable corn-belt farms have been invested in the Plains area. A settler would bring with him the latest in machinery for farming on a large scale, but would boastingly admit that he had not brought even one cow to supply the family needs. Instances are on record where in as short a time as four or five years these same settlers have accepted charity to enable them to leave the country. In favorable years the returns from wheat farming are big, but averaged over a series of years the income is most unreliable. When several poor years succeed one another, as is often the case, bills have to be carried over, and there is the real pinch of hard times.

## ADVANTAGES OF THE DAIRY HERD.

Compared with the precarious returns from wheat farming the dairy herd yields an income every day in the year. The season is frequently too dry to mature a grain crop, but seldom is it so dry that crops of forage can not be grown. Kafir, milo, sorghum, and



HOME OF JOHN CHRISTENSEN, NEW SALEM, N. DAK.

[The main house and barn are the third set of buildings erected. The small house and barn in the right of picture were the second. The original claim house and stock shelter have disappeared.]



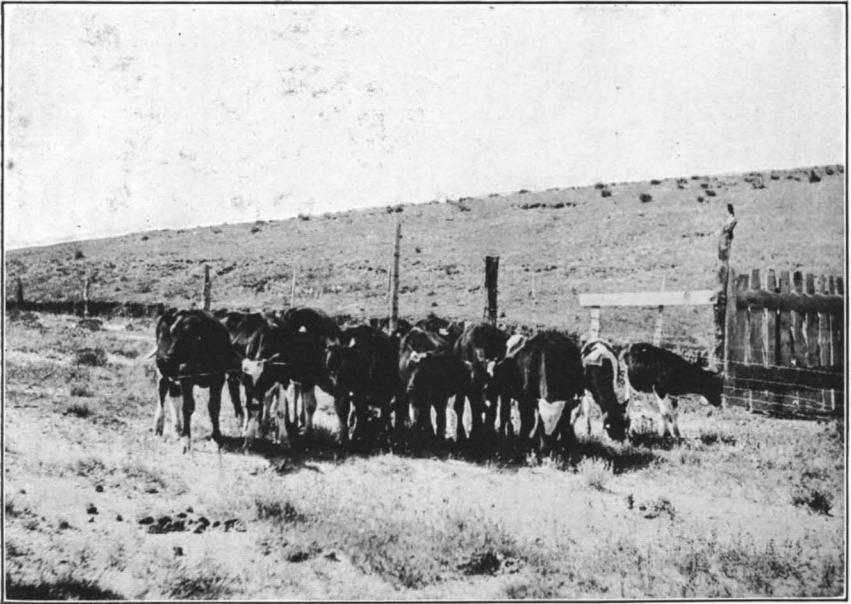

FIG. 1.—HALF-BLOOD HOLSTEIN CALVES FROM NATIVE COWS.



FIG. 2.—OAT HAY, LIMON, COLO, 1912.



FIG. 1.—KAFIR CORN, FLAGLER, COLO., 1912.



FIG. 2.—SORGHUM, FLAGLER, COLO., 1912.

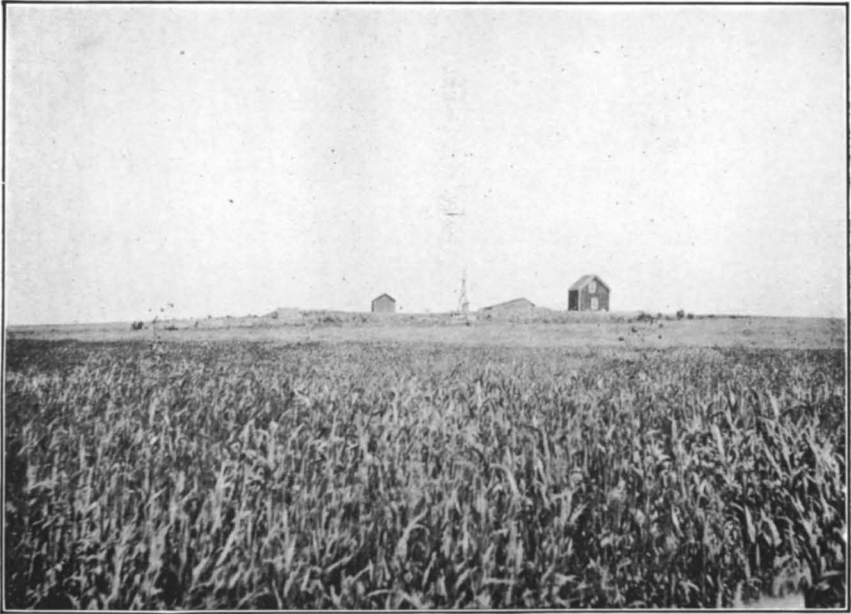

FIG. 1.—MILLET, GENEVA, COLO., 1912.



FIG. 2.—CORN FOR SILAGE, LIMON, COLO., 1912.

corn, while originally introduced for their grain, are reasonably certain as forage crops and can be depended upon practically regardless of the season. In favorable years they will mature grain and the surplus can be marketed for cash or, better, it can be stored for feed in less favorable years. The dry-land farmer is taking up dairying because the income is reliable. It enables him to make plans and to carry them through. Bills can be met and his credit is established.

Several years ago when there was a succession of crop failures a large mercantile company doing business in eastern Colorado refused further credit to its patrons, but made an exception in favor of the settler who was milking cows. Dairying is now well established throughout this firm's territory, and recently they issued a notice that after a certain date all their business would be on a cash basis. This is a hopeful sign. The standard of living is rising, and citizenship is improving. These things are possible because of the steady, dependable income from the sale of cream.

#### DAIRY FARMING PROFITABLE.

In North Dakota, where grain crops failed, two years ago the State legislature passed a bill enabling the counties to bond themselves for the price of the seed necessary to put in another crop. While this was going on generally over the State a dairy community in the western part was loaning money to its less fortunate neighbors, was building silos and barns, and buying automobiles.

It is assumed that primarily the farmer is a home builder and that he is on the farm because he believes that through it he can secure an income which will best give him the comforts of life and his just share of the luxuries. Wherever the dry-land farmer has made dairying the principal feature of his business and the cow a component part of his farm operation he seems fully able to have achieved this aim. (See Pl. LVII.)

One of the major factors contributing toward reliability of income is the ready market for the product. The price offered is not always encouraging, but it will doubtless improve as dairying develops. In towns where the receipts are considerable there are usually several cream-buying agencies, sometimes as many as four. The common practice is to secure a local merchant to act as buyer, who will receive, weigh, sample, and test the cream, and sometimes he issues payment in cash for each delivery. Districts remote from a railroad have their agencies, as well as the towns along the line.

Many of the older dairy communities have their local creamery or cheese factory. When these are located advantageously, they have a good trade with the mountain towns in sweet cream and milk, espe-

cially during the summer months. In a great many cases, though, the local creamery is closed or is being used as a receiving station by some foreign creamery.

Another cause for the popularity of dairying is the efficiency of the dairy cow in converting the crops of the field into concentrated merchantable form. As forage only, the crops of the dry-land farm have no market value and must be converted into a marketable product by feeding to live stock. Hogs are raised and fattened with profit in conjunction with the dairy, but even where alfalfa pasture is available they are not considered very profitable when run by themselves. The kind, and too frequently the quantity, of grain available for finishing is such that it is not possible to compete successfully with the corn belt. For similar reasons it is not generally practicable to attempt finishing beef cattle. The raising of feeders, however, should continue profitable for some time, and at present is conducted jointly with dairying, as most of the cows being milked are selected range stock and of the dual-purpose type. (Pl. LVIII, fig. 1.) In the opinion of those who have had experience the returns from the production of pork, beef, mutton, or butter fat, when averaged over a series of years, show a balance in favor of butter fat.

#### DAIRYING AND GRAIN GROWING NOT INCOMPATIBLE.

The keeping of a small dairy herd sufficient to meet current expenses need not interfere with the grain-growing possibilities of the farm. On the other hand, in good years the wheat crop can be sold for cash and the proceeds invested in improvements instead of being needed to apply on old bills. Dairying will enhance the profits of grain growing in several ways: First, in poor years, when it becomes apparent that the grain crop is going to be a failure as grain, it can be cut and harvested as hay, or pastured; or, if the grain is of a poor grade, it can be fed instead of marketed. Thus a total loss may be converted into only a partial failure because of the dairy herd. Second, results at our dry-land experiment stations show that following a cultivated crop like corn, the yield of wheat is as good, or better, than that following summer tillage. The expense of good summer fallowing is found about equal to that of growing a crop of corn. Fed to a dairy herd as silage, the corn crop is likely to average as profitable as any produced, and in addition, the cost of wheat production is reduced to the extent of the expense of summer tillage. Third, most valuable of all results, though, will be the improved physical, chemical, and biological condition of the soil because of the diversification of crops and the application of stable manure. In favorable years the yield and quality of grain will be improved, and in poor years drought will be less disastrous.

## DAIRYING ON A SMALL SCALE.

Dairying can be conducted profitably on a small scale and is possible to the settler with small capital. Sheep and beef cattle to be handled with profit require considerable investment of capital. A small dairy herd can be handled on every homestead, and the product, regardless of quantity, is marketable for cash at the nearest creamery. Cattle and sheep need to be shipped in car lots and should be of a uniform grade to realize the best market. The advantages of climate and of well water of a uniformly low temperature make it possible to produce a good quality of cream with inexpensive equipment in the way of barns and dairy houses.

## PRINCIPAL CROPS FOR THE SEMIARID REGION.

In the southern half of the Great Plains area the sorghums are the principal crops. Of these Kafir and milo are grown extensively and are used for hay and silage as well as grain. The grain of either has a feeding value about 90 per cent as good as corn. Kafir and milo make a very good silage. It is not the equal of corn silage, but very nearly so. It develops a little more acid than does corn, but this is not objectionable. Kafir is superior to milo as a hay crop, but the saccharine sorghums, commonly called cane, are considered the best for hay. The whole group of sorghums runs high in carbohydrate materials and is deficient in protein. (See Pls. LIX and LX.)

In the northern half of the Great Plains and in the lower altitudes of Utah and Idaho corn is the principal coarse forage crop. In favorable years it yields a crop of grain, but frequently early frost prevents the crop from maturing. Its principal value is as a silage crop. Oats and wheat are cut for hay (Pl. LVIII, fig. 2), and barley and emmer are the principal grain crops grown for feeding purposes. These feeds are all carbonaceous in character and need to be supplemented with a protein feed for best production.

In Utah and other sections of the Great Basin it is not unusual to find large crops of alfalfa being grown on a dry-land farm. During the last few years considerable success has been had in introducing this crop into the Great Plains area. Judging by the progress made, it is reasonable to expect that the work of breeding and selection will result in the general introduction of alfalfa throughout the whole semiarid section. In northern Colorado and northward, Canadian field peas are becoming an important crop. In a limited way Mexican beans and Spanish peanuts are being grown in the more southern sections.

## PASTURAGE.

To the prospective dairyman the pasture situation is perhaps the most discouraging. Where free range is available the native grasses will, in favorable years, supply an abundance of nutritious pasture. Practically every year the native grasses, if available, will support the dry cattle and heifers and keep them in a thrifty condition. Where the land has all been plowed and the native grasses destroyed a grass mixture consisting principally of bromus has been used successfully in providing a pasture. Only in the most favorable years, however, can one expect profitably to pasture the milking herd. The situation calls for all-the-year-round feeding of silage.

## CHARACTER OF THE CROPS.

Taken in the whole, the crops of the Great Plains area are at present largely carbohydrate in character, and for best results it is necessary to import feeds rich in protein. The more progressive dairymen, who are improving their herds and working for increased production, are doing this, but the great majority are depending entirely on dry feeding the home-grown crops.

In the Great Basin, where alfalfa is abundant, it is a common practice to make the ration almost exclusively alfalfa hay. This is not necessary, as the barley and other grains rich in carbohydrates that are grown on these farms are available and should be used in balancing up the ration. It is where alfalfa is grown that the feeding problem is simple and that the industry is most profitable.

## FEEDING.

The feeding practice that prevails on the average dry-land farm is more responsible for the low average production than is the quality of the stock in use. While pasture is available, production is fair, but very few herds are producers during the late winter months. Frequently the unbalanced ration of dry-fed forage brings on digestive troubles that too often prove fatal. The ration alone is not responsible for this, but the poor water supply, so common on the dry farm, is also at fault. The advent of dairying more than any other one thing is giving the careless settler a new interest in getting a good water supply, and it has aroused the whole Plains area to the need of growing legumes.

After going to the expense of time and labor to grow a crop every effort should be made to save that crop in its most useful and valuable form. This should be true where crops are abundant, but is imperative where crops are poor. The efficient and economical handling and storage of forage is the foundation of profit with live stock. The experience of the settler in handling and feeding the

forage crops of the Plains has developed methods that are in themselves fair, but in traveling over the Plains country one can not help but be impressed with the apparent waste. The practice of leaving the sorghum or corn crop in the field in the shock until needed is far too common. The high winds that prevail on the Plains carry away much of the nutritious part of the plant, and the balance is filled with blown soil so that it is not palatable. The loss through field curing is unusually high on the Plains.

#### THE VALUE OF THE SILO.

The general introduction of alfalfa will mark an epoch in the development of dry farming, but equally rich with possibilities is the coming of the silo. To the dairyman of the East the silo means the succulence of pasture all the year round, cheaper feeding, thrifty animals, and increased production. Adopted by the dry-land dairyman the silo loses none of its virtues and in addition becomes his one real effective weapon against drought. Every dry-land dairyman should have three times the silo capacity he expects to need in any one season. In favorable years it provides the extra storage room necessary for saving the large crop, and if several years of drought succeed one another, the reserve supply can be drawn upon to tide over the adversity. This reserve is his insurance against drought.

Destructive droughts sometimes occur when a crop is half or two-thirds grown. At such critical times the silo is of peculiar value for entirely saving the growth made. Under the present system of depending on pasture in summer and dry feeding in winter production is confined almost entirely to the summer months. The dairyman with a silo finds that production is possible all the year round, and that winter production is far more profitable because of the higher prices offered for the product. The silo is revolutionizing the whole feeding practice and is putting it on a sound basis. It awakens the settler to a realization of the benefits to be derived from other improvements, such as better shelter and the breeding up of his herd.

#### THE NEED FOR IMPROVED STOCK.

We have already said that poor feeding was principally responsible for the low average production of cows on the dry farm. The other factor is the limited dairy capacity of the stock employed. The cows are mostly from the old range stock, selected to some extent because of their milking qualities. Very little improved dairy stock has thus far been introduced. It is, perhaps, as well, as very few farmers are equipped to properly shelter and feed such stock. The cows they have are accustomed to the hardships of "rustling"



for much of their food and shelter. Put under the same conditions, improved dairy stock would probably not do as well.

Having a silo, the dry-land dairyman is assured of his feed supply and is prepared to undertake the improvement of his herd. The plan adopted by many, and the one to be recommended, is the purchase of sires of recognized dairy merit and then grading up, using the native stock on hand as a foundation. This is not as rapid as purchasing improved stock, but it is cheaper, and, furthermore, it gives the farmer an opportunity to develop his ability to feed and handle improved dairy stock. Some few registered females are being imported, but most of them are shipped as calves.

The unit of the herd is the individual cow, and intelligent herd improvement must be based on a system of individual cow records. Some few dairymen are keeping such records, but because of the general lack of them it is impossible to give much authentic data as to returns from dry-land dairying. A dairyman in eastern Colorado is able to show gross receipts, averaged for three years, of over \$80 per head, and without the use of a silo. A cow-testing association in North Dakota, about to close its second year, is able to show results even better, but the data of the association are not available for publication in this article. The average Plains cow is probably not producing 100 pounds of butter fat per year. By summing up the year's creamery returns it is possible to average the work of some herds. Such data are not always reliable, yet they would seem to indicate that some herds are averaging over 200 pounds of fat per year.

## AGRICULTURE IN PUBLIC HIGH SCHOOLS.

By DICK J. CROSBY,

*Specialist in Agricultural Education, Office of Experiment Stations.*

### RAPID DEVELOPMENT OF AGRICULTURAL EDUCATION.

More than 2,000 public high schools in the United States are now teaching agriculture; 16 years ago there was not one.

At the beginning of the present administration of the Department of Agriculture, in 1897, there were 61 State agricultural colleges and 9 agricultural schools—70 institutions in which agriculture was taught. Now agriculture is taught in about 2,600 State and private colleges, public and private agricultural schools, and public and private high schools.

This rapid growth of facilities for teaching agriculture has not extended over the whole of this 16-year period, but has been more marked in the last 4 years and most rapid in the last 2 years. Four years ago the agricultural-education service of the Office of Experiment Stations listed less than 350 institutions as teaching agriculture; two years ago, less than 900; now, about 2,600. Between 1908 and 1910 the number of institutions teaching agriculture was practically doubled, and between 1910 and 1912 this number was trebled. And while 16 years ago, or even 10 years ago, the public high schools were hardly thought of as effective agencies for the education of the rural people along vocational lines, at the present time they constitute over 80 per cent of the agencies engaged in teaching agriculture, not including, of course, the one-teacher elementary schools, which have never been listed by the department.

### TYPES OF SECONDARY SCHOOLS TEACHING AGRICULTURE.

There are several types of secondary schools in which agriculture is taught.

First in order of establishment and in value of agricultural equipment are the agricultural schools connected with State agricultural colleges, as in Minnesota and 36 other States. These schools use the land, live stock, farm equipment, and laboratories of the agricultural colleges, and their classes are largely taught by professors and instructors in the agricultural colleges.

Secondly, there are the separate agricultural schools, which include county schools, like those in Maryland, Michigan, Mississippi, North Carolina, and Wisconsin; congressional district schools, as in Alabama and Georgia; judicial district schools, as in Oklahoma; and schools serving larger districts, sometimes a whole State, as in Arkansas, California, Colorado, Massachusetts, Minnesota, New York, Pennsylvania, and Vermont. These schools have been established primarily for the purpose of teaching agriculture.

The third type of school is the public high school in which a department of agriculture has been established or a teacher of agriculture employed or an agricultural course conducted by a science teacher with some agricultural training. These are the schools to be discussed in this paper, and for convenience in this discussion they will be considered under two classes: (1) High schools receiving State aid for instruction in agriculture and (2) high schools teaching agriculture without State aid.

#### STATE AID FOR AGRICULTURE IN HIGH SCHOOLS.

Eleven States have appropriated funds to encourage the teaching of agriculture in existing public high schools, and one or two others have granted subsidies for conducting teachers' training courses in which agriculture is one of the subjects of instruction.

Virginia was first of the 11 States to make a specific appropriation for the teaching of agriculture in public high schools. In 1908 the Virginia Assembly appropriated \$20,000 to enable the State board of education to inaugurate courses in agriculture, home economics, and manual training in at least 1 public high school in each of the 10 congressional districts of the State and in 1912 increased the appropriation to \$65,000, including \$25,000 to aid the schools in providing buildings and equipment and \$10,000 for extension work to be conducted by them. There is nothing in the legislation to indicate how much money each school shall receive, because the number of schools to be aided, and hence the amount available for each, is not stipulated, this whole matter being left to the discretion of the State board of education. At the present time, however, 10 schools, 1 in each congressional district, are dividing the funds equally.

Virginia was followed in 1909 by Maine and Minnesota. At that time Maine gave funds for instruction in agriculture and other industrial subjects in incorporated academies, but two years later an act was passed extending such aid to free high schools—two-thirds of the total expenditure for instruction in agriculture, home economics, and mechanic arts, but not to exceed \$500 a year to any one school. In 1912, 8 schools in Maine received State aid for agriculture.

Minnesota passed an act giving \$2,500 to each of 10 high, graded, or consolidated rural schools maintaining courses in agriculture, home

economics, and manual training, and the work of these 10 schools proved to be so popular that in 1911 the legislature extended State aid at the rate of \$2,500 a year to 20 additional schools and also passed another act giving \$1,000 a year to each of 50 schools to aid in maintaining courses in agriculture and either in home economics or in manual training. The schools of Minnesota were not slow to take advantage of the opportunities for State aid, and as soon as the funds were available a full quota of schools, 80 in all, had qualified to receive them.

In 1910 Louisiana, Maryland, and New York passed somewhat similar laws. Louisiana first appropriated a lump sum—\$25,000 a year—to be used by the State board of education in subsidizing high schools maintaining agricultural departments, but has since doubled the appropriation. The State board of education, having full power to fix the requirements under which State aid would be granted, outlined the following as a minimum: Each school must have a demonstration farm of at least 5 acres, fenced against rabbits, chickens, and stock, and an option on 5 acres more, if needed; there must be a barn with at least five stalls for horses and cattle, a weevil-proof grain bin, fertilizer and tool rooms, and a hayloft; the agricultural departments of approved high schools shall have at least \$100 worth of apparatus for teaching agriculture, in addition to the regular apparatus for such schools, and those not on the approved list must have \$100 worth of apparatus for agriculture and from \$75 to \$150 worth of other apparatus; the school must also have at least \$40 worth of tools and \$140 worth of farm implements, an appropriation of at least \$250 for maintenance annually, and must own a horse or a mule. The teacher of agriculture must be a graduate of an agricultural college, with some practical experience in farming, and must be satisfactory to the department of education; he can not be principal of the school and must not be required to teach any class in the school outside the department of agriculture except in botany and zoology, if these subjects are given an agricultural trend; he must be employed for 12 months in the year. Not more than 20 schools were to be aided the first year, but the number has considerably increased since then, so that in 1912, 25 schools were on the list.

Maryland gives State aid to its public high schools to encourage good salaries for teachers and to stimulate the establishment of courses in agriculture, home economics, and manual training. In the act of 1910 it was provided that high schools of the first group—4-year schools having not less than 80 pupils and 4 teachers—should receive from the State \$400 on account of each of 2 teachers of special subjects (agriculture, home economics, or manual training), and that high schools of the second group—3-year high schools having 35

pupils and 2 teachers—should receive \$400 on account of 1 teacher of a special subject. Six schools qualified for State aid under this act in 1912, and four or five others have qualified for the school year just opened.

Maryland has four or five schools that should be included here in the class of State-aided public high schools, because they receive the same State aid, under the same regulations, as other public high schools of the State, but these schools are also included among special agricultural schools because they were established primarily for the purpose of teaching agriculture.

In New York the legislature of 1910 made provision that any city school or union free school maintaining for a minimum of 38 weeks in a year independently organized schools (here meaning nearly the same as "department" or "course" in other States) of agriculture, mechanic arts, and home making, and employing 1 teacher whose work is devoted exclusively to such school, and having at least 25 pupils, should receive \$500 for each such independent department, and the further sum of \$200 for each additional department teacher. According to the regulations of the commissioner of education, the teacher of agriculture must hold a special certificate and devote his entire time to the teaching of his special subject. Furthermore, "classes of book study only in agriculture and home making are not entitled to the benefits of the law establishing these courses." Seventeen schools qualified under this act and received State aid in 1912.

In 1911 Kansas, Massachusetts, North Dakota, Texas, and Wisconsin were added to the list of States giving aid for the teaching of agriculture and related subjects. In Kansas \$25,000 was appropriated to enable the State board of education to give \$250 for the maintenance of a course in agriculture and home economics in each high school having a normal training course provided for under a previous act. One hundred schools applied for State aid at the opening of the year 1912, and nearly all of them qualified.

The Massachusetts Assembly appropriated \$10,000 to pay two-thirds of the salary of teachers of agriculture employed by cities and towns in "local or district independent agricultural schools consisting only of agricultural departments in high schools." These schools or departments of agriculture must meet the approval of the State board of education "as to organization, control, location, equipment, courses of study, qualifications of teachers, methods of instruction, conditions of admission, employment of pupils, and expenditures of money." The State board has moved rather slowly and cautiously in making its plans for these schools, and has made its requirements so rigid as to type of teacher and cooperation of neighboring farmers in the practical instruction that only four schools have thus far qualified for State aid.

The act passed by the Legislature of North Dakota is almost exactly the same as the Putnam Act in Minnesota, giving \$2,500 to each school maintaining courses in agriculture, home economics, and manual training, but the number of schools to be established in the first year was limited to five.

In Texas \$50,000 a year was appropriated for the purpose of duplicating local appropriations, as follows: In high schools of the first and second class, agriculture, \$500 to \$1,500; home economics, \$500 to \$1,000; and manual training, \$500 to \$1,000; in high schools of the third class, agriculture, \$500 to \$1,000. No school may receive in one year more than \$2,000 from the State, and "such appropriation shall not be made more than twice to the same school." In 1912, 34 schools received State aid under this act.

Wisconsin adopted a plan similar to that in New York, giving to any "free high school or a high school having a course of study equivalent" thereto \$250 for each special department maintained only in the high-school years, or \$350 for each such department maintained in the high school and in "the three upper grades next below the high school." This law is to be administered by the State superintendent of public instruction, and he, in cooperation with the college of agriculture, has outlined an agricultural course involving four high-school units in agriculture and agricultural chemistry. Fifteen schools qualified under this act in 1912.

Thus, with State aid varying from \$250 to \$3,000 to each school, nearly 300 high schools have employed special teachers of agriculture and secured more or less special equipment for the classroom, laboratory, and field work of the students, and are making good progress toward the realization of the hope of many educators that the high school shall ultimately become the people's college.

#### HIGH-SCHOOL AGRICULTURE WITHOUT STATE AID.

While only 11 States give financial aid to the teaching of agriculture in high schools, many more encourage such work, and all but Delaware and Rhode Island have one or more high schools in which agriculture is taught. And it is not always in the States where agricultural instruction is subsidized that we find the largest number of high-school courses in that subject. Ohio, without subsidies, has 335 high schools on our agricultural lists; Nebraska, with 191, is next; and Missouri, with 167, is third, while the largest number in any State that subsidizes agricultural courses is 132 in Kansas and Minnesota—the same number in each State—counting both subsidized and unsubsidized schools.

A study of the geographical distribution of public high schools in which agriculture is taught—both aided and unaided schools—reveals the interesting fact that two-thirds of them are in the 12 States con-

stituting the group known as the North Central States and one-third in the 36 other States. The two groups of States in the Mississippi Valley, known as the North Central and South Central States, contain 1,478 of the 1,910 schools, or more than 77 per cent of them. The remaining 432 schools are about evenly distributed among the other three groups of States, the North Atlantic States having 185, the South Atlantic 129, and the Western 118.

At first thought this distribution seems greatly out of proportion, but it is not so. When we consider the fact that these two central groups of States contain two-thirds of the farm population of the United States it does not seem so very strange that they should have three-fourths of the high schools in which agriculture is taught; nor are we greatly surprised to learn that the agricultural colleges in these States enroll over 64 per cent of the college students in agriculture in the United States. The hopeful thing about it all is the fact that the best agricultural regions are recognizing the value of agricultural education and providing so generously for its support.

*Agriculture in high schools and academies in the United States.*

State.	Receiv- ing State aid.	Without State aid.	Total.	State.	Receiv- ing State aid.	Without State aid.	Total.
Alabama.....		37	37	Nevada.....		3	3
Arizona.....		1	1	New Hampshire.....		6	6
Arkansas.....		14	14	New Jersey.....		2	2
California.....		42	42	New Mexico.....		1	1
Colorado.....		11	11	New York.....	17	25	42
Connecticut.....		1	1	North Carolina.....		20	20
Delaware.....				North Dakota.....		19	19
Florida.....		14	14	Ohio.....		335	335
Georgia.....		9	9	Oklahoma.....		19	19
Idaho.....		10	10	Oregon.....		6	6
Illinois.....		25	25	Pennsylvania.....		85	85
Indiana.....		62	62	Rhode Island.....			
Iowa.....		43	43	South Carolina.....		6	6
Kansas.....	93	39	132	South Dakota.....		12	12
Kentucky.....		5	5	Tennessee.....		34	34
Louisiana.....	25	3	28	Texas.....	34	21	55
Maine.....	8	5	13	Utah.....		19	19
Maryland.....	6	2	8	Vermont.....		6	6
Massachusetts.....	4	26	30	Virginia.....	10	42	52
Michigan.....		38	38	Washington.....		19	19
Minnesota.....	77	55	132	West Virginia.....		20	20
Mississippi.....		12	12	Wisconsin.....	15	103	118
Missouri.....		167	167	Wyoming.....		1	1
Montana.....		5	5				
Nebraska.....		191	191	Total.....	289	1,621	1,910

CHARACTER OF INSTRUCTION IN AGRICULTURE.

The instruction in agriculture in public high schools is becoming almost as varied in character as that in the agricultural colleges. It

now includes the work of the classroom, the laboratory and shop, the field and garden, and the community in which the high school is located.

#### CLASSROOM INSTRUCTION.

The length of time devoted to agriculture in the public high schools varies from one semester to four years, but the tendency is undoubtedly toward a four-year course, particularly in high schools receiving State aid for agriculture.

In the four-year agricultural course it frequently happens that the first year is devoted to a general course in agriculture, the pupils using one of the elementary textbooks, of which there are now a dozen or more adapted to the different geographical regions of the country. When this plan is followed the other three years are usually devoted to the principal divisions of agriculture, with the use of textbooks on special phases of the subject, supplemented by lectures, bulletins, and reference books.

There are two or three excellent textbooks of agriculture prepared with special reference to the needs of the high schools, but the supply of textbooks on special subjects, such as agronomy, animal husbandry, dairying, horticulture, and farm mechanics, is far from being adequate or satisfactory.

#### LABORATORY AND FIELD WORK.

Full recognition seems to be given to the necessity of supplementing the work of the classroom by laboratory exercises and field tests in order to make the instruction in agriculture a thing of vital concern to the school and the community. As a result of this nearly all schools are providing as liberally for apparatus and equipment as their financial means will permit. In the well-equipped high school in which agriculture, home economics, and farm mechanics are taught it is the usual thing to find about three laboratories, one devoted to agriculture, another to home economics, and a third to shop work. In the agricultural laboratory it is not unusual to find some equipment for work in soils and crops, some for dairy work, and possibly a little for work in horticulture.

#### AGRONOMY.

The apparatus for soil work usually includes soil tubes, balances, thermometers, and considerable chemical glassware, besides microscopes, which are also used for work in farm crops. In addition there are frequently collections of soils, seeds, and farm crops, appliances for testing seeds, and some provision for water and gas on the laboratory tables.



The laboratory work in soils and crops includes, usually, a number of exercises in soil physics, the mechanical analyses of soils, and some experiments in pots with soils, fertilizers, and plants. In the farm-crops work, seed testing and grading (Pl. LXI), comparison of types of cereals and forage crops, and a variety of pot experiments cover about the usual range.

The crop work is frequently carried on out of doors to a larger extent than in the laboratory, especially where arrangements can be made for carrying on the work throughout the growing season. School gardens are quite common in connection with high schools (Pl. LXII, fig. 1), corn-breeding plats are maintained by a number of schools (Pl. LXII, fig. 2), and demonstration plats are not uncommon. A few schools have raised purebred seed corn to sell to the farmers of the community.

The field work as carried on at Bonham High School, in Texas, is an interesting example of what can be done by high-school students. The first-year students have complete charge of the school farm of  $5\frac{1}{2}$  acres, and upon them rests the responsibility of preparing the ground, selecting the seed, planning the rotations, and planting the various crops.

The farm is divided into one-fifth and one-tenth acre plats, which are permanently staked and numbered, and their location is accurately indicated on blue prints made by the boys. Under the direction of the manual-training teacher the boys have built a house 16 by 30 feet, with a loft capacity of about 6 tons of cereals or forage. This house is being used for the storage of implements, tools, seeds, and produce, as well as for class work in seed testing, grading, and other indoor activities of the farm.

All of the common cereal, forage, and horticultural crops of the region have been grown, and a series of simple field tests have been started to demonstrate the local application of principles that have already been established elsewhere. Following are some of the demonstrations that have been undertaken: (1) That barnyard manure is valuable and should be utilized; (2) that crop rotation is a necessary feature in successful agriculture and that legumes should occupy a prominent part in these rotations; (3) that winter cover crops are essential in retaining soil fertility in the South; (4) that improved seeds are important for high yields and should be selected annually from the growing crop; (5) that early surface cultivation for conservation of moisture is necessary as a safeguard against possible drought in July and August; (6) that deep plowing rather than shallow is necessary on upland soils to retard erosion; and (7) that the better cultivation of fewer acres and diversified farming involves less risk, distributes the work more uniformly throughout the year,

and in the end is more profitable than straight farming to cotton and corn.

#### ANIMAL HUSBANDRY AND DAIRYING.

The laboratory and field work in animal husbandry usually consists of judging exercises involving the use of the tapeline and score card upon animals owned by neighboring farmers. This work also frequently involves the study of stable facilities for farm animals and the criticism of barns and other structures for beef and dairy cattle, swine, and poultry.

The fact that high-school boys at Hadley, Mass., won first and second prizes in the 1912 State judging contest, after having only such practice as was afforded by neighboring farm animals, is an indication of the value and importance of utilizing the facilities of the home farm in agricultural school work.

In the dairy work of the schools it is quite common to find some apparatus in the agricultural laboratory, such as a Babcock tester, a cream separator, churns, and score cards. The students' work in the laboratory includes the testing of whole milk from different cows in the neighborhood and skim milk from different types of separators, occasionally a few exercises in making butter, and frequent exercises in scoring dairy animals and dairy buildings. It is frequently possible for the enthusiastic teacher of agriculture so to direct the dairy instruction of the school as to bring about great improvement in the dairy herds of the community and improvement in dairy practice as to the feeding of animals and the sanitary handling of milk.

#### HORTICULTURE.

If horticulture is made a feature of the instruction in agriculture, there are not infrequently a small greenhouse (Pl. LXIII, fig. 1), a hot-bed or two, a cold frame, and some facilities for gardening. Many schools make provision for exercises in grafting and budding fruit trees, and some of them have small nurseries of seedling apple and peach trees, which have been grown by the students for practice purposes. (Pl. LXIII, fig. 2.)

The laboratory or greenhouse work in horticulture includes not only grafting and budding but seeding, pricking out, potting, and scoring and judging fruit.

At the Gardena Agricultural School, in Los Angeles, over 2 acres are devoted to horticultural experiments, variety tests, and tests of fruits hitherto unknown to the region. The effort here is to stimulate a comparative study of fruits from different parts of the world for the purpose of finding new things adapted to the climate of southern California, and to encourage the people to acquire a taste for them.

## RURAL ENGINEERING AND FARM MECHANICS.

In the rural engineering phases of instruction there is usually some drainage work, irrigation in semiarid regions, and shopwork. The field work in drainage includes some practice in surveying, planning, and laying out drains, and occasionally in laying drain tile on school farms. In irrigation there are instances where high-school students have put in water systems complete from the making of plans to the distribution of water over the plats. (Pl. LXIII, fig. 3.)

The shopwork as carried on in many of the schools up to the present time savors too much of manual-training exercises in city schools, but there are some schools in which formal exercise work, such as the making of joints, tenons, dovetails, and the cutting of gears and threads, has been reduced to a minimum; in which the making of useful articles for the farm, like gates, fences, and small buildings, has taken the place of cabinetwork and patterns for the foundry; where the work in the forge shop includes the making of rings, hooks, clevises, and other useful articles, and the repair of farm machinery, instead of fancywork for exhibition purposes; where the pupils learn to put in waterworks, plumbing, concrete walks, and foundations; where they make small greenhouses, lath houses, and cloth houses for horticultural work (Pl. LXIII, figs. 4, 5, 6), and actually erect some of the buildings needed by the school. Examples of this new point of view are found at the Bonham High School and the Gardena Agricultural School, referred to above. The board in charge of the latter school recently made an appropriation for a barn on the school farm, and, instead of having it erected by contract, employed a head carpenter and several assistants, not to erect the barn but to supervise the work of the students in the agricultural course in the construction of it.

Progress in this direction, in making the farm mechanics' work of the high schools applicable to farm conditions, is very encouraging. (Pl. LXIV.) There is no reason why work so conducted can not be made just as educational as the more formal manual-training work and at the same time be far more useful to the students in their later work on the farm.

## COMMUNITY WORK.

A new conception of high schools is growing apace with the development of vocational courses in these institutions. People are coming to see in them possibilities for service to all members of the community, to the students in the school, the parents at home, the young people who have left school, and the teachers in neighboring elementary schools. The character of community work that high

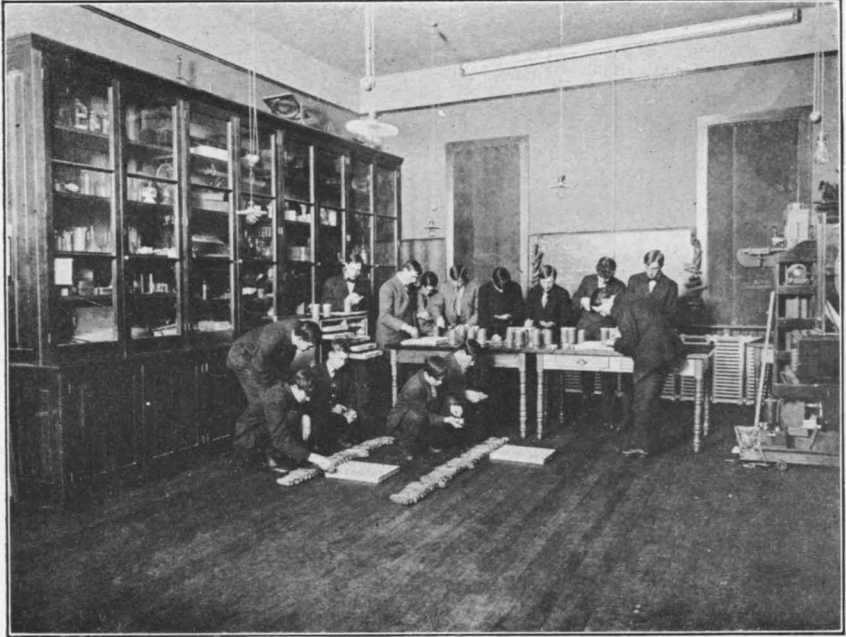

FIG. 1.—HIGH-SCHOOL STUDENTS IN MINNESOTA TESTING SEEDS FOR PURITY AND VIABILITY.

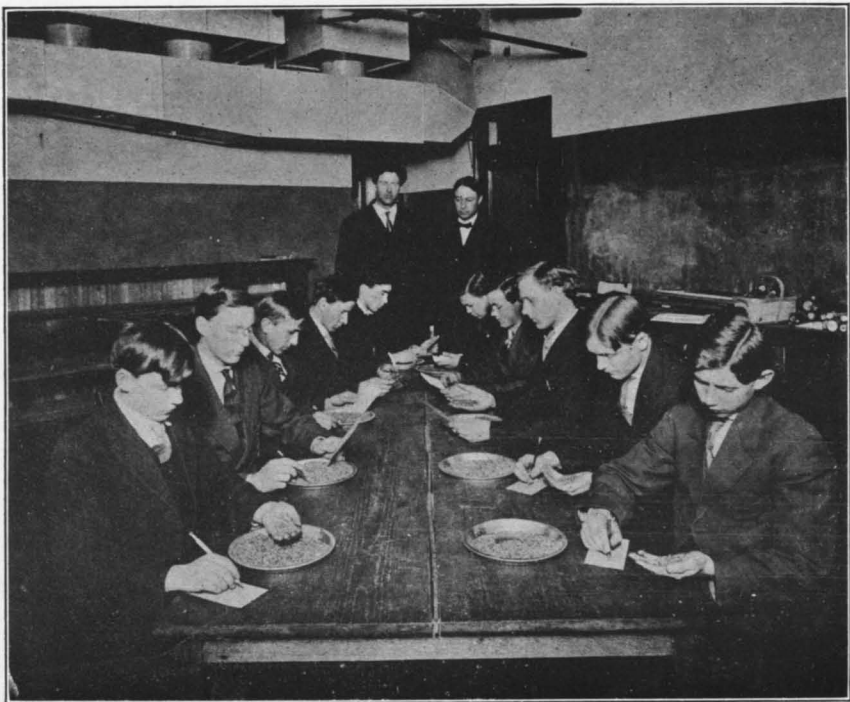

FIG. 2.—MINNESOTA HIGH-SCHOOL STUDENTS JUDGING AND GRADING WHEAT.

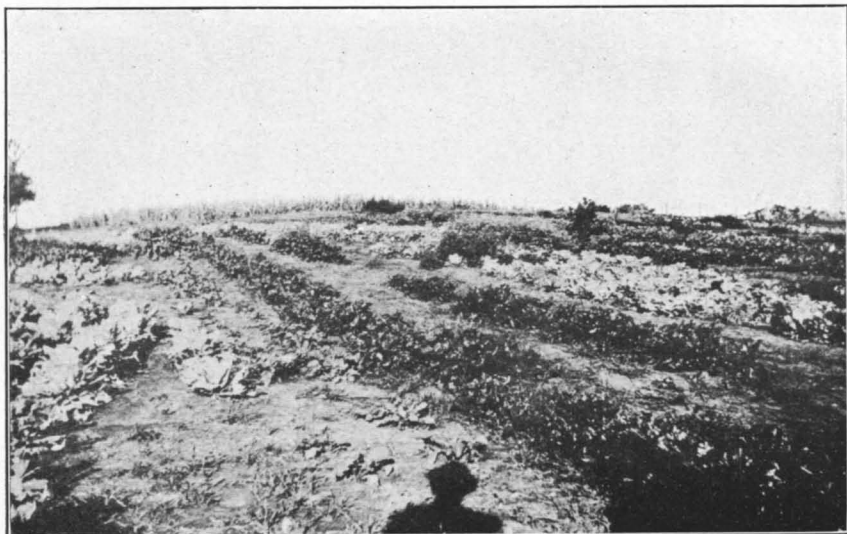

FIG. 1.—FALL VEGETABLES IN HIGH-SCHOOL GARDENS AT COIN, IOWA.



FIG. 2.—COIN HIGH-SCHOOL BUILDING, WITH CORN-BREEDING PLAT AT RIGHT.

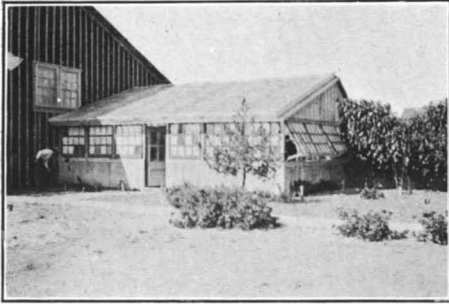

FIG. 1.—GREENHOUSE MADE BY STUDENTS AT OXNARD, CAL.



FIG. 2.—SCHOOL NURSERY AT OXNARD.

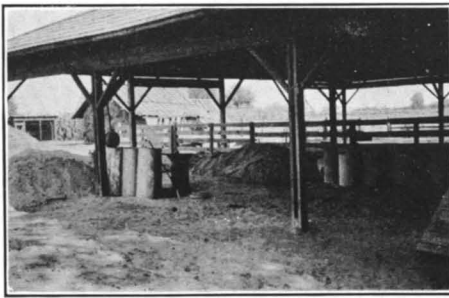

FIG. 3.—IRRIGATING TILE MADE BY BAKERSFIELD, CAL., BOYS.

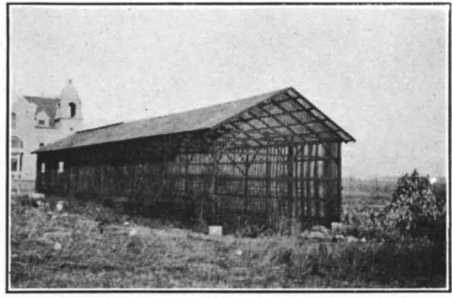

FIG. 4.—LATH HOUSE AT LORDSBURG, CAL.

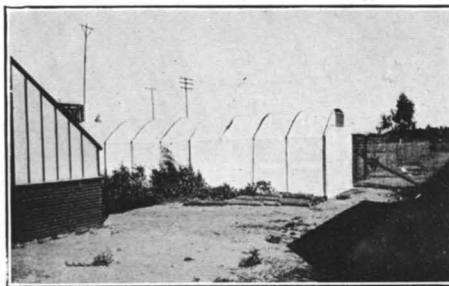

FIG. 5.—CLOTH HOUSE AT GARDENA, CAL.

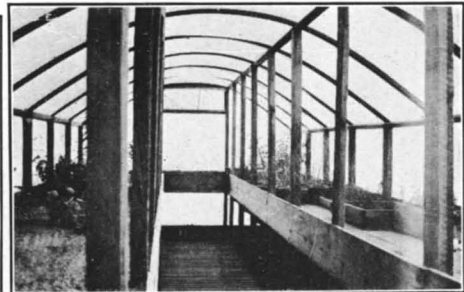

FIG. 6.—INTERIOR OF CLOTH HOUSE.

SHOP AND FIELD WORK OF HIGH-SCHOOL STUDENTS.

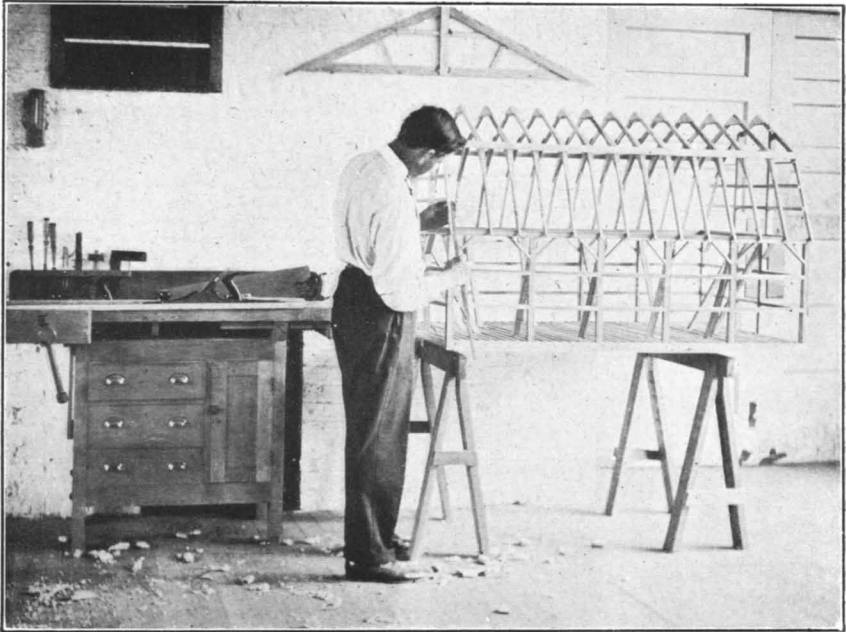

FIG. 1.—FARM MECHANICS IN THE SHOP. MAKING A MODEL BARN FRAME.

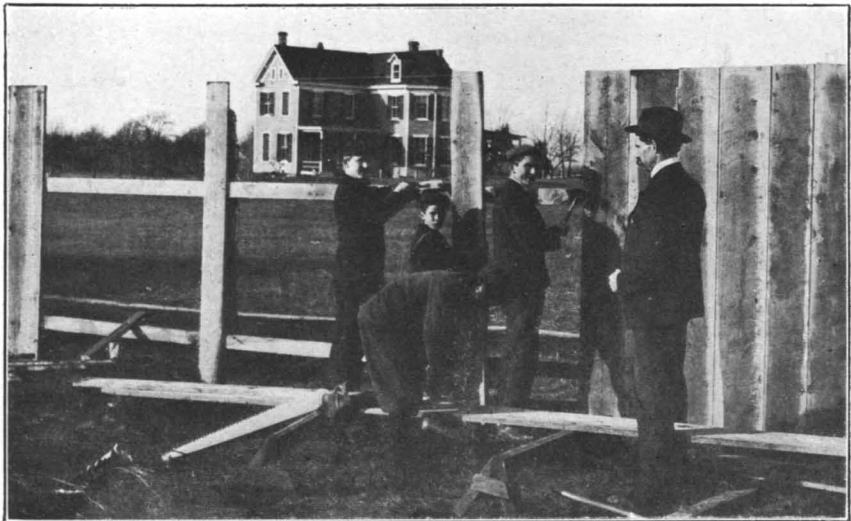

FIG. 2.—OUTDOOR FARM MECHANICS AT MANASSAS, VA.

schools have already undertaken is described at some length in an article entitled "Community Work in the Rural High School," in the Yearbook for 1910, but considerable progress has been made in the development of community work since that time. Examples are on record of high schools cooperating with State colleges of agriculture in running agricultural trains, conducting demonstrations, holding short courses for farmers, and performing various other useful services. One teacher of agriculture got his first hold on his farmer constituents by going to the market place on market days, getting up on a box, and talking to them about the importance of spraying their potatoes, and by demonstrating the use of spraying apparatus and solutions there in the market place.

Boys' and girls' club work has been successfully conducted and supervised by the teachers of agriculture and home economics in public high schools. These teachers have also performed useful services by visiting rural schools and helping the teachers in them to give instruction worth while in nature study and elementary agriculture. They have secured the loan of Babcock milk testers and then passed them around among the rural-school teachers, so that pupils in the grammar grades might learn how to use these pieces of apparatus for the purpose of improving the dairy cattle of the neighborhoods. Wherever a live teacher of agriculture, well prepared and enthusiastic, has studied the local problems in agriculture, there community work of some kind has been done. Seldom is such work patterned wholly after the work of other teachers. The problems of the rural people are so different in one community from those in another that the greatest latitude is given to the ingenuity and resourcefulness of those teachers who are earnestly seeking for opportunities to render the greatest service to the people who employ them.

#### INFLUENCE OF HIGH-SCHOOL AGRICULTURE.

Wherever the teaching of agriculture in high schools has been taken seriously, wherever suitable equipment and capable teachers have been provided, the schools and everyone connected with them have been benefited; the attendance has increased; the school work has assumed a more businesslike air, as if it dealt with the realities of life, with real problems instead of imaginary ones; and the relations between teachers, pupils, and parents have become closer and more sympathetic.

The boys in school have gone about their work more cheerfully; it has seemed to them worth while—a part of the business of life—and they are less anxious to get away from it "to begin doing something," as boys used to say. They stay in school longer; many boys in the agricultural courses are older than those in the other courses—



boys who would be going out to swell the ranks of incompetent, half-educated, half-waged labor if it were not for the appeal of this new scientific and businesslike approach to this oldest but least understood human occupation.

Agriculture, if well taught in the high schools, dignifies an ancient occupation and exalts the home and homely duties; it develops in the boys a thoughtful and studious attitude toward a great business which is likely soon to occupy many of them in the serious affairs of making a home and a living for themselves; it trains them to think and speak more accurately, but to be less dogmatic; it "holds the mirror up to nature" and teaches those who hold "communion with her visible forms" to understand her "various language."

High schools in which agriculture is something more than a new textbook subject, in which it reaches out to the surrounding homes and farms for its problems and illustrative material, soon acquire a hold and exert an influence upon the community such as other schools have never been able to get. The people come to know the school better and are loyal to it. They have a feeling that it is theirs, that it is worth while, and they go deeper into their pockets to support it. They see that it is educating their sons—not for some allurements in the distant future, but for life in the world to-day, in the home neighborhood, in another State, or wherever they go. Moreover, they feel that the school is a school for everybody—of educational, social, and pecuniary benefit to all.

To these people it is not so important that a new subject has been added to the curriculum as that the school has changed front. Instead of trying to educate a select few for high professional positions, it is endeavoring to make a better people and a better land.

## THE SETTLEMENT OF IRRIGATED LANDS.

By CARL S. SCOFIELD,

*Agriculturist in Charge, Western Irrigation Agriculture, Bureau of Plant Industry.*

### INTRODUCTION.

The utilization of arid lands by means of irrigation has gone on in this country during the last half century with greatly increasing rapidity. The earlier efforts in this direction were but sporadic attempts to produce a few of the necessities of life in remote desert spots which had been invaded by hardy pioneers engaged in mining or other nonagricultural pursuits. Later came the discovery that large areas in our western deserts possessed a combination of soil, climate, and water supply well suited to the production of abundant and profitable crops and the maintenance of comfortable homes. This has resulted in extensive investments of capital, both private and public, in the construction of storage and diversion works for irrigation.

Many of the earlier irrigation enterprises were hazardous, not only because of the cheapness and inadequacy of the dams and ditches, but also because the State laws relating to the use of water were not satisfactory or were not well enforced. The quarrels and litigation that arose in times of water scarcity were conspicuous features of irrigation farming. During the early period, irrigation followed the pioneer instead of being provided in advance. More recently, with the improvement of State laws and of the administration of regulations governing the allotment and use of water, irrigation has been undertaken on a larger scale, and lands have become available somewhat faster than they have been effectively occupied. The lack of a sufficient number of settlers of the right kind has led to efforts on the part of those interested to promote the settlement of the irrigated land. These activities have taken many directions, and numerous agencies have been enlisted in them.

The need of rapid settlement is more acute on irrigated than on unirrigated land, because when an irrigation project is completed and ready for settlement it represents a large investment of capital on which interest charges must be paid. Any unutilized land within

the limits of such a project not contributing its share to the payment of this and other fixed charges throws added burdens on the land that is occupied. It is therefore much to the advantage of all concerned to promote rapid settlement in order to distribute these charges more equitably.

Various motives are involved in the different movements looking to the settling of new areas. Some of these motives appear to be so selfish and shortsighted as to be almost piratical, while others are entirely beneficent and patriotic. The motive is not always clear, but this may not be important, since the motive and the result may be quite independent of each other. In other words, an enterprise started with the best of intentions may prove unfortunate, while another which owes its impetus to purely selfish interests may in the end prove very advantageous to settler and promoter alike.

The aim of the present paper is not so much to discuss the motives of land promotion and colonization schemes as to present some of the agricultural and sociological features of such undertakings for the consideration both of those who are engaged in promoting settlement and of the larger number who contemplate settlement in newly irrigated regions.

Probably the most important point to be made in this connection is that the proper development of a new region requires more than the mere occupation of the land by people engaged in crop production. In many of these new regions the conditions are so conspicuously favorable for the production of crops that other and equally important needs and opportunities are sometimes overlooked. The production of crops for profit should not be the sole aim of the settler. Nor is the ultimate best interest of the promoter served when this aim is given too large a share of attention. This is particularly true when interest is focused on the production of some one crop.

#### TWO CLASSES OF LAND SEEKERS.

A better understanding of the problems of settlement is to be had through an appreciation of the needs and desires of the settlers. From this standpoint land seekers may be divided into two classes. The first class includes those who are interested chiefly in opportunities to speculate in land and who are attracted to new projects on this account. The second class includes those who seriously desire to make homes on the land and engage in agriculture or kindred pursuits as their chief means of livelihood. When a new project is opened for settlement the first rush is made by those who have no fixed interests elsewhere, who are foot-loose and dissatisfied with their previous conditions. Those who are dissatisfied in one place are not unlikely to be dissatisfied in another and to move again on the slightest inducement. But where rapid colonization is

imperative it may be necessary to draw largely from this nomadic class. It should be kept in mind that such settlers may serve a useful purpose during the early period of settlement, since they are generally reconciled to the hardships of pioneering and do much to prepare the way for the permanent settlers who follow. But in the long run the slower moving and more conservative settler must be secured, and where it is desired to establish a permanent and prosperous community every effort should be directed to securing colonists of this class.

#### THE PROFESSIONAL PIONEER.

A certain proportion of our people are ill at ease among the comforts and restrictions of advanced social conditions. For some of these there is a strong appeal in the hazards, rigors, and stimulations of pioneer existence. A new region also offers the chance of large profits through increases in land values. There are many people to whom the rigors of pioneering are merely stimulating, while to others they are hardships. Some enjoy the risks involved in speculation; others prefer the safer, if slower, profits of crop production.

The professional pioneer has been a real factor in the development of irrigated lands. Essentially he is a gambler, ready to stake all his means, his labor for a brief period, and his share of the creature comforts of civilization on the prospective profits in land values as the new region develops. Whether he wins or loses, he is ready after a time to go to another place and try again. The professional pioneer is as old as our American civilization. He has preceded every wave of settlement, and in some cases the same individual has helped to break ground successively in four or five places.

While the professional pioneer is an important and conspicuous factor in the early development of a new region, he takes but little part in its ultimate prosperity. He is gradually replaced by the more conservative settler whose ambitions lie in the direction of home making, crop production, and the other varied industries of an established community. Many of the discouragements experienced by those who have fostered colonization enterprises have been due to misconceptions regarding the motives and inclinations of the first comers. It is not to be expected that a large proportion of them will long remain or that they will share with enthusiasm in the larger plans for permanent community improvements. They bear the brunt of the conflict with new conditions and unexpected difficulties. The rewards they get for their risks and their services are none too large, all things considered. But it is a mistake to frame a policy based on the supposition that all new settlers intend to remain and to become permanent members of the new community. During the early stages it is to be expected that many readjustments will take place, and

attempts to restrict such readjustments are likely to hinder rather than to promote ultimate prosperity.

Under the methods of settlement now generally practiced the best that can be expected is to sift out from the stream of land seekers the small percentage who really desire permanent homes and gradually to replace those who wish to move on to newer fields.

#### THE INFLATION OF LAND VALUES.

One of the most serious difficulties encountered in the settlement of our irrigated lands lies in the inflation of land values on new projects. Desert land is usually very cheap. The development of irrigation, of course, gives occasion for a large increase in value. Then, as agricultural and industrial development begins and the demand for land becomes acute the future prospects are immediately capitalized. Not infrequently in the first exuberant optimism hopes run too high. There is something infectious about rapidly increasing land values, and in the midst of a boom it seems easy to forget that in the final analysis agricultural land is worth no more than it can be made to produce.

The larger profits of the first settlers are derived from increased land values rather than from crop production. As a result each newcomer seeks to obtain his share of the unearned increment by investing all his available capital in land instead of looking for industrial opportunities. In fact, a large majority of the first settlers in a new region are more interested in prospective profits to be obtained from increased land values than in all other opportunities combined. Land can not be expected to be bought and sold indefinitely at a profit to each successive owner. Yet it would appear that each new purchaser has faith that he will be able to sell again before the crisis comes.

In view of the instability of conditions in our irrigated sections and of the rapid evolution now going on, it is not possible to determine an exact standard of values for irrigated land. It seems hardly fair to make comparisons with equally productive sections in the humid regions, because of the differences in the classes of crops produced and of other important economic factors. It would also be unwise to make comparisons with irrigated lands in the Old World for similar reasons. It might be safe to assume that, in general, the values of irrigated land should range somewhat higher than similar unirrigated lands, and in some few cases very much higher. There can be no doubt, however, that generally the prices of newly irrigated land in private ownership range rather higher than their producing capacity and the prevailing economic conditions warrant.

One of the chief arguments in favor of a colonization policy, under which irrigated land must be occupied for a long term of years by

the first settler, lies in the resulting discouragement to this speculative inflation of values; but it is hard to devise a system of land settlement involving ownership which is at the same time proof against speculative purchase and sale. With a view to avoiding still further certain undesirable features of the present systems, it might be worth the experiment to try opening new irrigated land on some system of leasing with ultimate options for purchase.

It is quite true that the increase of land values is one of the most attractive features in a new country and one of the most powerful incentives in securing the first settlers. Without this prospect settlement would be a much slower and probably a more difficult task. Yet this might be less disadvantageous than it seems. There can be no question that the quick overinflation of land values, with its consequent disturbance of economic conditions, is one of the most serious deterrents to the permanent settlement and development of a new region.

#### THE DIVERSIFICATION OF INDUSTRIES.

It has been pointed out in an earlier paper<sup>1</sup> that the proper diversification of industries on each farm, as well as in the community, should be one of the most important aims in a newly settled region. It can not be doubted that the sooner in the life of a community this diversification can be started the better for all concerned. The diversification of industries should not be confined to the farms. Very soon after a new community gets started there is an overproduction of one crop or of a few crops, and a period of depression is experienced until satisfactory markets are found and trade relations established. This period of depression will be shortened in proportion to the people in the community who are engaged in industries other than crop production.

It is not always possible to start very many industrial enterprises at once, nor would this be wholly desirable, but it is often possible to do much more in this direction than is done at present. If more attention were to be given to establishing in a new region a larger proportion of people engaged in the working up of farm products and in other forms of industry, the relation between production and consumption of the products of the farm would be much better maintained and the general prosperity would be much more quickly realized. Many of the new settlers have previously followed vocations other than farming, and if at least a few of them would continue in the new region the work to which they are accustomed a much better balance of economic conditions would result.

<sup>1</sup> The present outlook for irrigation farming. Yearbook, U. S. Department of Agriculture, for 1911, pp. 371-382.

There is much that may be done by those who promote the occupation of land in the way of encouraging diversification from the first. Almost everything done in this direction tends toward lessening the hardships of pioneering, as well as toward hastening the prosperity of the community.

Very often the settlers in a new region do not grow their own garden vegetables or provide themselves with chickens or cows. Through the early stages they will do without some of these necessities or import them at high prices because they are devoting their own attention to the production of the so-called money crops.

#### ASSISTING NEW SETTLERS.

The question as to what extent the agency which brings water to the land on a new project shall engage in fostering the best use of that land is one about which there is much difference of opinion. There is always a strong inducement for the agency which has put money into the development of water for a tract of land to follow the matter up and protect its investment by promoting rapid settlement and quick and effective utilization. These efforts if properly directed may result in no bad after effects, but it is always possible that when not so directed more harm than good may result.

Each new irrigation enterprise means the establishment of a new community the members of which are usually not acquainted with one another and are often unfamiliar with the problems they have to meet. In attacking these problems they may greatly desire advice and guidance, but it should be kept in mind that ultimate success is to be realized only through individual initiative and community action.

It is to be assumed that the promoter is more familiar with conditions in the region than is the new settler and that he has fully as keen an interest in the ultimate success of the project.

There is a great variety of practice in regard to the aid given by colonization agencies to new settlers. In some instances the promoter goes no further than to place the settler on the land and take such precautions as he may to guard himself against loss in case the settler fails to make good. In other cases the promoter takes elaborate pains to aid the settler with advice, encouragement, and assistance. Each of these methods has its advantages and its drawbacks, and the final test of each is to be found in the results accomplished, and these in turn are largely influenced by the local conditions.

Paternalistic methods which involve close supervision of the individual may result in a larger proportion of successes with a given number of settlers, and the ultimate prosperity may be hastened if

the advice, encouragement, and assistance are of the right sort. But there are real dangers in this direction which should not be overlooked. At best, such methods must be regarded as a sort of artificial stimulation. It is easy to get people to shift their own responsibilities to other shoulders. If these responsibilities are accepted too readily, it becomes increasingly difficult to shift them back again or even to place new ones where they belong, that is, with the individual. Then, too, the conditions of a new region may not be well understood, even by those who have given the most time to the study of them, and the advice given to new settlers may not be of the best. There are always many things to learn in a new region, and it is much better if a large number of people are engaged in the learning and in the practical application of the results to their own work.

The alternative extreme of permitting the new settler to shift for himself is sometimes less heartless than it seems; also it is not wholly unprofitable from the purely financial standpoint of the promoter. The settler who starts and fails may be replaced quickly with another, bringing in additional capital and fresh enthusiasm. There is seldom a lack of occupants for land which is properly exploited, and even in the face of repeated failures new people will come in to try again. But it is not to be understood that those who begin without advice always fail. Indeed, it is frequently the case that people thrown thus on their own resources respond with extra efforts and with greater ingenuity to meet and overcome the new conditions. It is certainly true that once success is attained by the independent community, it is better prepared to go on and to overcome any new obstacles that may arise later.

On the whole it is very doubtful whether the settlement of our irrigated lands requires that the promoting or developing agencies go much further than to give the new settler a fair chance to make good through his own effort and initiative. If aid is to be given him it is better that it take the direction of helping him to inform himself about conditions, of helping him to get information for himself rather than to force upon him information for which he feels but little need, even though it may be important for him to have.

#### EARLY PHYSICAL IMPROVEMENTS.

The physical hardships that accompany the life of the pioneer are often severe at the best and constitute the chief deterrent to securing the best class of settlers. Many of these hardships could be much lessened or avoided entirely were such a course accepted by the promoter as his best policy. Telephone lines, good roads, good schools, and churches are important and tangible assets to a new community and both directly and indirectly react in beneficial ways.



It is, of course, a question of financial policy with those who are establishing a new project as to whether or not they shall provide at first certain of these improvements. There can be no doubt that the improvement of roads alone would often result in the conservation of much effort otherwise wasted in hauling supplies and farm products over new and often nearly impassable roads. On projects where the initial expense of irrigation construction is high and where prompt settlement and development are desired, it might be well worth while for the promoting agency to go to the relatively small expense required for the construction and maintenance of roads for the first few years, in order to aid the new settlers in their first struggles.

Expenditure of money in these early improvements not only makes success easier for those who come, but aids very greatly in securing at the outset the most desirable class of settlers, for there are good farmers and home makers who do not care to go through a long period of hardship for themselves or their families.

The need for attention to such details is greater than it was a generation or more ago. Throughout our older agricultural regions the physical conditions of life have been much improved. Families moving into new regions feel keenly the lack of the facilities to which they have become accustomed. This is particularly true of those who come from cities and towns. The possibility of providing such advantages as those enumerated is much better on irrigated land than it is where the farms are larger and more scattered. It is also easier to start trees and shrubs in public grounds and along the roads than is usually the case in the unirrigated land now open for settlement in the West. Such improvements if wisely made are likely to be among the most highly appreciated features of a new community and the cost should not be large in comparison with the engineering features of the modern irrigation project.

#### COMMUNITY ACTION AND RELATIONSHIPS.

The colonization of unirrigated lands usually proceeds peripherally by scattered outposts from already established communities. Irrigated lands, on the other hand, are usually isolated from other settlements and are relatively thickly settled from the first. This results in conditions wholly different from those with which the American people are generally familiar in pioneering. A newly settled irrigated region presents a complex sociological problem, because people from many different places and of many different kinds are suddenly thrown closely together and confronted with problems which can be solved only by united action. An isolated community is comparable to an organism rather than to a mere aggregation of indi-

viduals, and in an organism the relationships and functions of the parts must be such as to conduce to the well-being of the whole. The sooner the members of a new community come to realize this the sooner they are able to make real progress.

Problems of this class are not to be solved merely by efforts toward cooperative buying, selling, and manufacturing on the part of those who are engaged chiefly in agricultural production. It is true that such efforts are helpful, not only in themselves, but in the training they afford to meet other problems. But there is need for other forms of community action. There is need in each community for men who specialize for the common good in directions other than agricultural production and who can devote their whole time and energy to such work.

The chief objection that is urged against specialization in non-productive enterprises in any community is the tendency toward parasitism, toward activities that are not really beneficial to the community. This is a real danger, but one that may be minimized, if not wholly avoided, by a certain degree of cooperative relationship and supervision.

There is much that may be done by the promoters of a new project in the way of leading the organization of effort in a new community and of encouraging both intelligent cooperation and specialization. The success of a new region may depend quite as much upon the right sort of cooperative work and upon the right sort of people to lead it as upon the right sort of crops or of methods of production.

The chief difficulty with such cooperative effort is usually found to be a lack of expert knowledge in the business and of substantial continuity in its administration. In other words, it is hard for people to learn to work together effectively and unselfishly. It should be realized that the successful management and operation of a business enterprise often requires special talent. Such talent commands good wages and is not always easy to find. It requires a high degree of community confidence to accomplish good results in the cooperative management of manufacturing or commercial enterprises. In new regions the best results are to be had through providing the fullest publicity concerning enterprises in which all the people are interested, and the private management of these is likely to be advantageous rather than otherwise.

#### EXTRAVAGANT EXPLOITATION.

One of the conspicuous features of the settlement of irrigated land is the campaign of advertising carried on by the various agencies interested. Probably no other class of land is made the subject of such extravagant claims or of such highly colored literature. The natural result of such exploitation is to arouse hopes in the minds of

the ignorant and suspicions in the minds of the well informed, and both the hopes and the suspicions may be without full justification. Most of our irrigated lands offer fair opportunities for farming and kindred occupations. Considering the initial cost and the risks involved, irrigation opportunities do not differ much from many others open to our people. It should not be necessary to make such extraordinary efforts to attract settlers, and the fact that this is done tends to discredit the motives of the promoters. The aggregate area of available irrigated land is so small in proportion to the unirrigated land available for settlement that were the opportunities offered by the former really much superior it would be impossible to supply the demand. Our people are accustomed to the settlement of new areas. No other country on the globe has witnessed such a vast movement as has gone on in the United States during the last half century and is still going on.

The real need of our irrigated lands is to secure settlers who have some means with which to make a start and who will be content with a fair interest on their investment and a fair livelihood from farming. As long as the great bulk of the advertising literature on irrigation opportunities is so extravagant it will be difficult to secure this class of settlers. It is not aimed at them and does not interest them. It appeals instead to a class who know little or nothing about farming, but who are dissatisfied where they are and who hope to find in some new project a veritable Eldorado. A few of these may by chance become successful farmers, but the proportion is likely to be small.

Irrigated lands possess real advantages over unirrigated areas. And when an irrigated section is ready for settlers it is to the interest of all concerned that it be settled quickly, for, as already stated, the investment for the irrigation works and the expenses of operation and upkeep must be carried whether all the land is in production or not. For this reason it may be desirable to devote some attention to methods of securing quickly the necessary settlers. There are, of course, a great variety of methods to be followed in encouraging the right kind of colonization, but it seems clear that in general the best success will follow the use of methods which do not require extravagant overstatement and which will give a large share of attention to the proper selection of the settlers.

#### STATE RELATIONS TO SETTLEMENT.

In recent years there has come to be a recognition of the fact that the State has a vital interest in new land activities within its borders. Certain of our Western and Southern States have recognized this to the extent of making appropriations and creating commissions to supervise efforts in this direction. In other cases the States

make requirements of those who would engage in exploitation and settlement enterprises. Usually these requirements in the Western States have had to do with some form of registration or guaranty on the part of the promoters with regard to the water supply alleged to be available for irrigation. Such supervision on the part of the State, if efficiently and wisely exercised, must have a beneficial effect.

Still further progress is needed in this direction. There is a large demand for impartial and reliable information concerning new irrigation enterprises, and in most cases no recognized source for such information exists. The present widespread distrust concerning these enterprises is likely to increase unless some means is found for supplying reliable information.

#### CONCLUSIONS.

The settlement of irrigated lands has become a serious problem in recent years because these lands have been opened for settlement rather faster than they have been effectively occupied. It is important that irrigated land be settled promptly, since the investments made in the construction and operation of irrigation works constitute a charge against the land whether it is used or not.

Land seekers are of two kinds—those who are chiefly concerned in land speculation and those who desire to make homes on the land and engage in agricultural production. The majority of new settlers belong to the first class.

Many of the first settlers on new projects are professional pioneers. They are accustomed to the hardships and privations of new conditions and play an important part in opening new regions. Under our present methods of colonization the establishment of a permanent community must take place slowly by the gradual replacement of many of the early settlers by others who are slower to move.

The rapid rise of land values in newly irrigated regions is one of the chief deterrents to permanent settlement. Very often land is held by speculators who do not intend to develop it, and their prices are so high that those who would improve it and bring it into production can not afford to do so.

There is need for greater diversification of crops and of industries on newly irrigated lands. The exclusive production of a few special crops results in abnormal economic conditions and often seriously retards the development of the region. The first aim of new settlers should be to produce the bulk of their own food and later to encourage the establishment of manufacturing enterprises to better utilize their products.

Efforts to foster the development of a new community by aiding and advising the settlers should be made cautiously. The problems

of a new region are often not well understood, and it is usually more profitable to help the settlers learn for themselves and work together than merely to teach them methods that have been successful elsewhere but which may not apply locally.

In the establishment of irrigation projects it might be practicable to provide good roads and certain other physical improvements of which the cost would be relatively small. Such improvements would make it much easier to attract a better class of settlers.

Irrigated lands are usually isolated from other settlements and relatively thickly settled from the first. These conditions result in the need for community action in many matters. Cooperative activities are valuable in the direct results they give, and still more so in the training they afford in community action.

The extravagant exploitation of irrigated lands has tended to react unfavorably. People who are not familiar with agricultural matters are often inspired with hopes destined to be disappointed, while those who are acquainted with such matters are likely to regard with suspicion any project about which it seems necessary to make extraordinary claims. Irrigation opportunities are not, as a rule, much better than opportunities elsewhere, but they are usually good enough to justify interest without such highly colored advertising as is generally resorted to.

There is a tendency on the part of some of the States to provide impartial information as to their irrigation opportunities. Such information is much needed and greatly benefits all the interests concerned.

## SOME NEW GRASSES FOR THE SOUTH.

By R. A. OAKLEY,

*Agronomist, Office of Forage-Crop Investigations, Bureau of Plant Industry.*

### INTRODUCTION.

There is much interest attached to the introduction and testing of new crops, especially when these crops belong to a class that is of great agricultural importance. Since the beginning of systematic plant introduction by the Department of Agriculture the native and cultivated forage crops of the world have been studied with a view to securing new and valuable species for sections where the need has been the greatest. The search has been particularly close for hay crops adapted to the South and to the dry lands of the West, where natural conditions are not well suited to the plants that are most commonly cultivated for hay. Native and foreign species have been tried, and even those that gave only remote indications of value were tested, with the hope that they might succeed under new environment. In this work history and experience have taught the value of introduced species, foreign countries having yielded a majority of our most important hay crops. With one possible exception, our native flora has added nothing to our list of cultivated grasses in recent years, and the prospect of domesticating any of our valuable native species not already in cultivation seems now to be very remote. It is because of this that attention has been directed to Europe, Asia, Africa, and other countries for new material. In the course of its work the Department of Agriculture has introduced a large number of species and varieties of true grasses; and while, as might be expected, a great majority of these showed little or no promise for our conditions, there were some whose value was apparent almost from the first.

Though always interesting, it is rarely the case that the introduction and testing of new crops result in the spectacular. The newcomers that have proved successful have done so usually after an extended period of testing and in a very modest manner. Among the grasses that have been received within the past few years, however, are species that promise to be exceptions to the rule. Not only are they practically assured a place among our cultivated crops, but one species especially seems likely to produce a material change

in the agriculture of the region to which it is adapted. These grasses are Rhodes grass (*Chloris gayana* Kunth) and Sudan grass (*Andropogon sorghum* Bret.); also, possibly another form of sorghum—Tunis grass. Rhodes grass is adapted only to the extreme South, while Sudan grass and Tunis grass are suited to a much wider area. All of these species were procured from Africa, where, at the time of their introduction, they were grown under cultivation only to a very limited extent.

Rhodes grass was introduced into Australia about the same time as into this country, and is now fast becoming an important forage crop there. There is no record of Sudan grass or Tunis grass being cultivated to any extent in any part of the world, and it is probable that there will be more of the former at least grown under cultivation in the United States next year than in all the other countries combined. We have growing wild in this country species of the genus to which Rhodes grass belongs, none of which are of much agricultural value, and under cultivation many relatives of Sudan grass and Tunis grass—the sorghums and Johnson grass—all very important crops.

While not closely related botanically, and differing materially in important characteristics, Rhodes grass and Sudan grass have proved almost equally promising in the preliminary tests in the sections to which they are apparently adapted, and are almost certain to become staple hay crops within a comparatively short time.

#### RHODES GRASS.

The history of the introduction of Rhodes grass under cultivation is by no means complete, but the available records indicate that it was first cultivated by Cecil Rhodes at Cape Town, South Africa, probably about 1895. Mr. Rhodes, seeing the grass growing wild and appreciating its possibilities under cultivation, had seed collected and sown on his estate, "Groote Schur." When visited in 1903 by Messrs. Lathrop and Fairchild, who were interested in introducing plants for this country, the grass had already proved its merit and was attracting much attention locally. A small quantity of seed was procured and sent to the Department of Agriculture under S. P. I. No. 9608. This is the first introduction of Rhodes grass into the United States of which there is a record. Accompanying the packet of seed was a note by Mr. Fairchild giving a brief account of the grass on Mr. Rhodes's estate and a description of it under cultivation. The original importation was received under the botanical name *Chloris virgata*, and was so recorded in the published inventory. This mistake, however, was the result of confusion in connection with the common names of the two species and was corrected later when the grasses were more carefully studied.

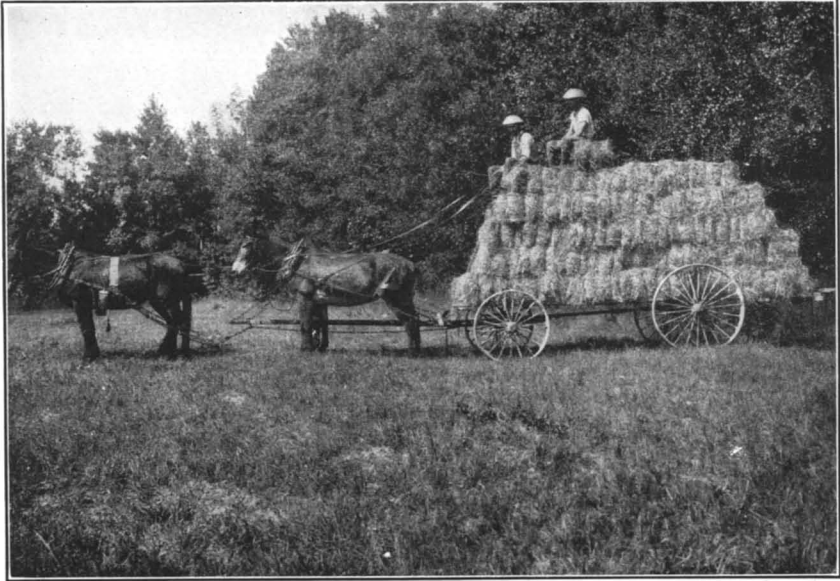

FIG. 1.—FIRST LOAD OF BALED RHODES-GRASS HAY PRODUCED IN THIS COUNTRY.  
[Grown at Brooksville, Fla., 1912.]

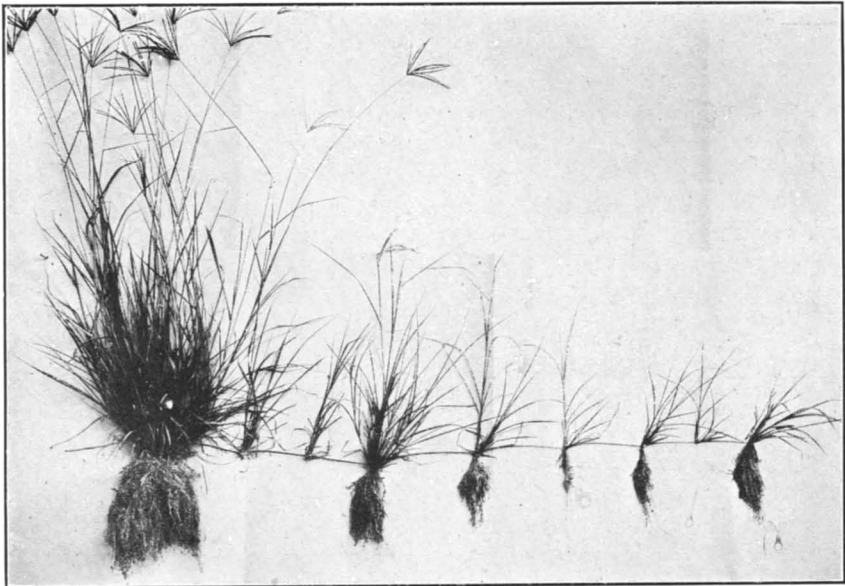

FIG. 2.—RHODES GRASS, SHOWING THE CHARACTERISTIC HABIT OF THE RUNNERS IN  
PRODUCING NEW PLANTS AT THE NODES.

[Note the absence of rootstocks.]





RHODES GRASS, SHOWING ITS GENERAL HABIT OF GROWTH.



FIG. 1.—THE THIRD CUTTING OF RHODES-GRASS HAY.  
[A portion of a 20-acre field, Brooksville, Fla.]



FIG. 2.—TUNIS GRASS.  
[Note the comparatively fine stems and more or less open habit of growth.]

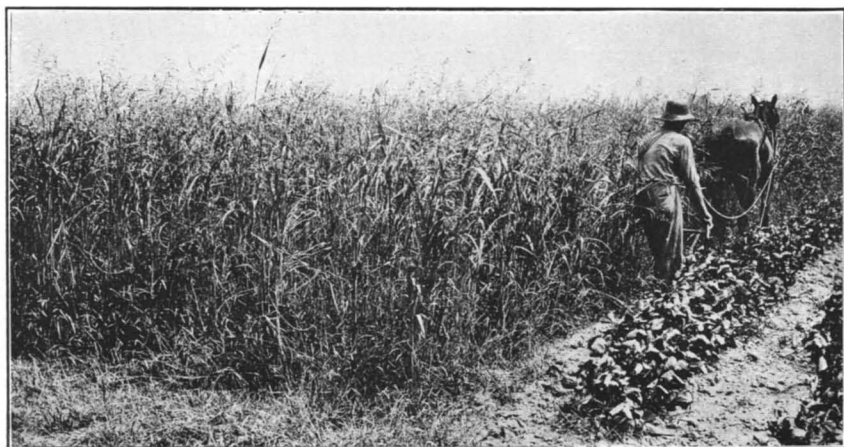

FIG. 1.—A FIELD OF SUDAN GRASS SEEDED IN 18-INCH ROWS.

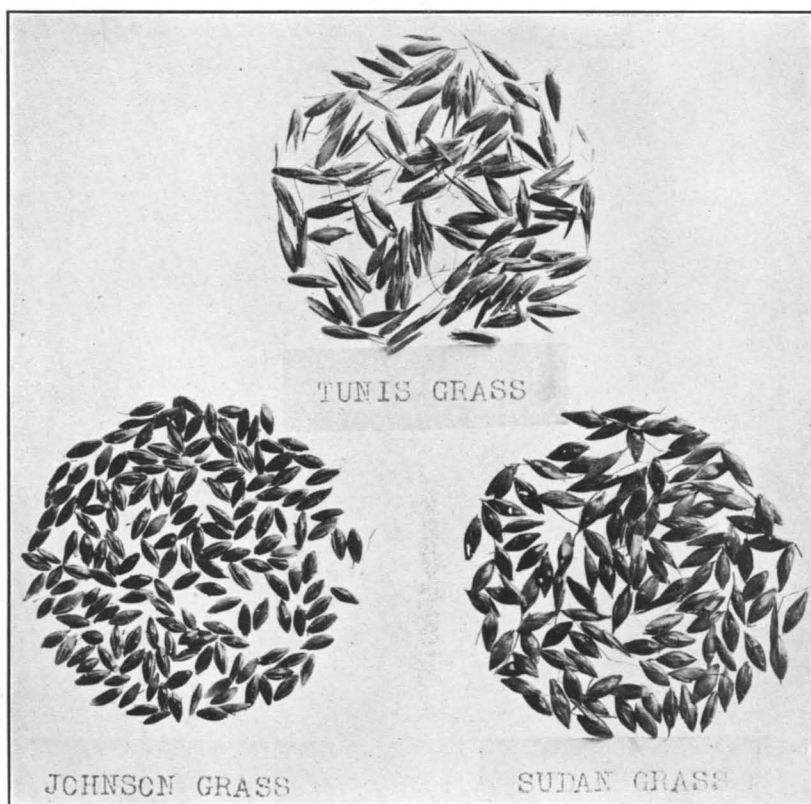
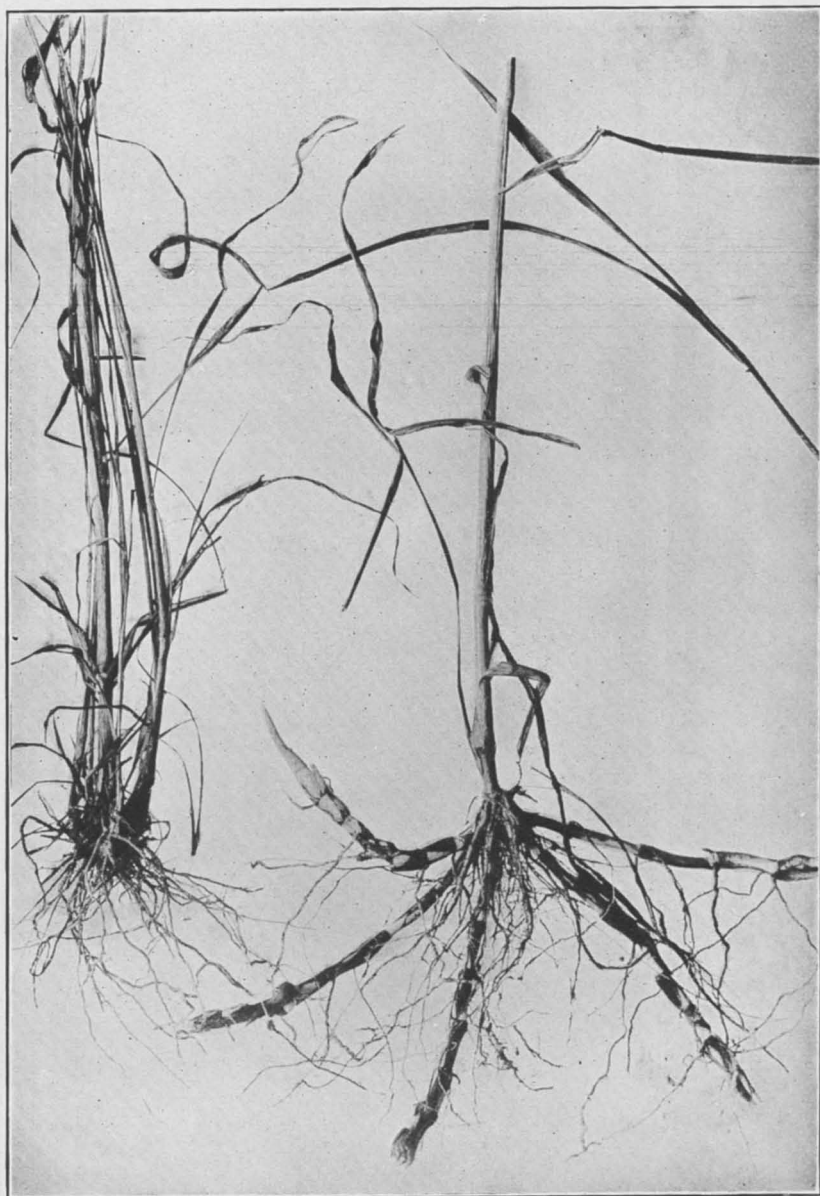
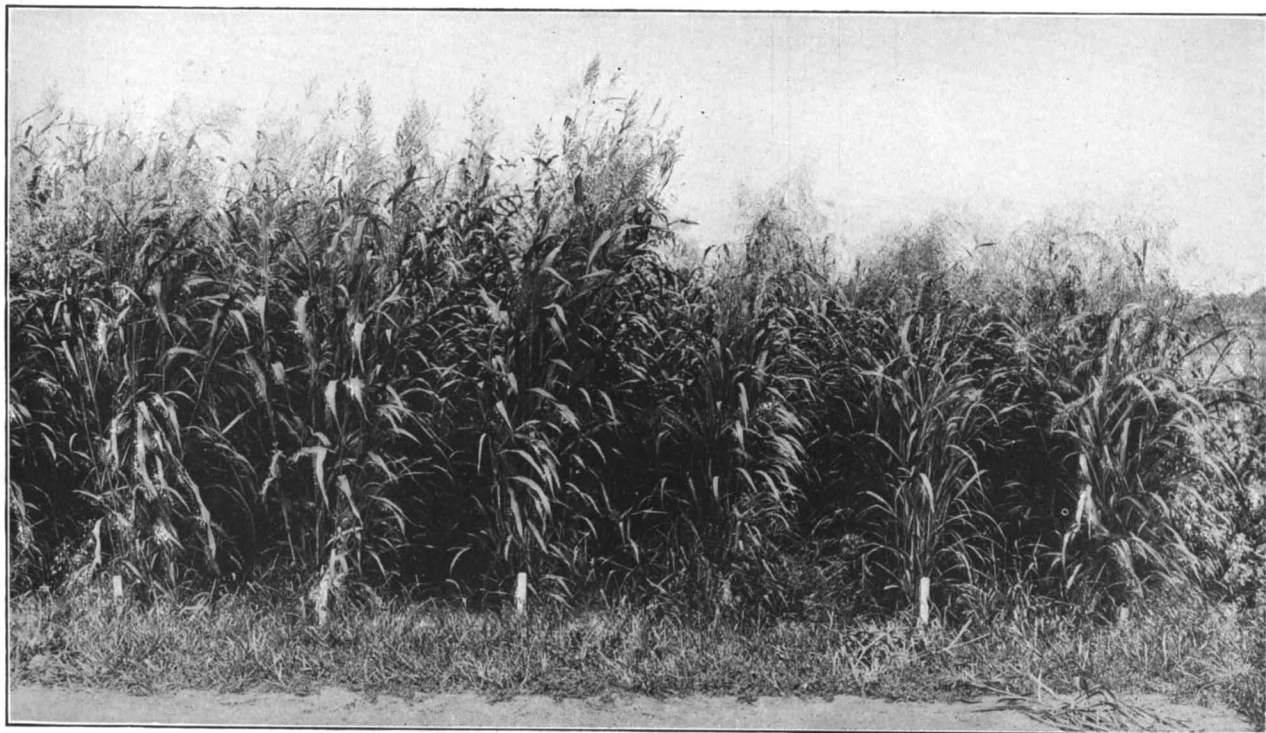

FIG. 2.—SEEDS OF TUNIS GRASS, JOHNSON GRASS, AND SUDAN GRASS. (NATURAL SIZE.)  
[Note the size and plumpness of the Sudan-grass seed and the smoothness with which seed of Johnson grass and Tunis grass break from the seed head or panicle.]



ROOT SYSTEMS OF SUDAN GRASS AND JOHNSON GRASS.

[The Sudan grass on the left is entirely devoid of rootstocks. The Johnson grass on the right has the rootstocks well developed.]



NATURAL HYBRIDS OF SUDAN GRASS AND HYBRIDS.

[The three rows on the left resemble Amber sorghum in general habit of growth, while those on the right are quite characteristic of Sudan grass.]

Owing to the very small quantity of seed originally introduced and the inadequate facilities of the department for testing at that time, Rhodes grass did not attract much attention in this country until 1909, when a sufficient quantity was secured to permit of testing on a small scale in many parts of the South. The preliminary trials continued until 1910, removing all doubt of the advisability of testing this grass on a field scale, even though the seed still remained very high in price.

While Rhodes grass was being tested in the United States it was also being tried in Australia, where the seed became a commercial commodity in a very short time. In the fall of 1911 several hundred pounds of seed were purchased from seedsmen in Sydney and put out in the spring of 1912 in fields varying in size from one-fourth acre to 20 acres. The first load of baled Rhodes-grass hay produced in this country is shown in Plate LXV, figure 1. Out of 43 reports recently received from these tests, 21 were enthusiastically favorable, 15 were favorable, and only 7 unfavorable. In almost every case where failure was reported the cause was readily apparent. It is needless to say that the percentage of success was unusually high—greater than might be expected even in the case of a staple crop. In many cases the reports read almost like fiction, but these perhaps should be more or less discounted because of the short duration of the tests.

Excellent evidence regarding the prospective value of Rhodes grass is found in the fact that the farmers in Florida have placed and are now placing with Australian seedsmen orders for seed far in excess of the supply, and these orders are intended not for experimental tests, but for actual farm use.

#### CHARACTERISTICS OF RHODES GRASS.

As before indicated, Rhodes grass is a native of subtropical Africa, whence it has become distributed to many parts of the world. It is a perennial species which does not spread by underground root-stocks but produces running branches which root at the joints or nodes, thereby producing new plants. (Pl. LXV, fig. 2.) These runners are not so abundant when the grass is growing thickly, and therefore do not materially interfere with the machinery at the time of harvesting the hay crop. The grass produces fine culms or stems which bear leaves for almost their entire length, and on top of which are borne branching or fingerlike seed heads or panicles. (See Pl. LXVI for general habit of growth.) The seed of Rhodes grass breaks from the panicle with the chaff or glumes and is about the size of Kentucky bluegrass seed, but much lighter in weight, weigh-

ing approximately only  $7\frac{1}{2}$  pounds per bushel. The glume is tipped with a short bristle or awn, but this does not make sowing difficult.

To be a valuable hay grass a species must possess certain important characteristics. It must be aggressive, or at least able to maintain itself for a considerable length of time against weeds and other enemies; it must furnish a profitable yield; it must be palatable and nutritious, and possess a good color and general appearance, either loose or in the bale, when cured; and it must have reasonably good seed habits. Rhodes grass has all of these qualities, and besides it seems to be able to grow on poor soil and is also fairly drought resistant. Its inability to withstand low temperatures, however, limits materially its area in the United States.

While the seed habits of this grass are not equal to those of timothy, owing to uneven ripening and tendency to shatter, it is already established on the markets in Australia and doubtless will be in this country very soon.

Although aggressive, Rhodes grass is not at all difficult to eradicate from cultivated fields, since the runners by which it spreads are on the surface of the ground and are not true rootstocks such as are produced by Johnson grass and other species having similar habits. (See Pl. LXV, fig. 2.) This is a very important character, as it makes the grass aggressive against weeds and at the same time not as a weed.

#### RHODES-GRASS HAY.

While there has not been sufficient experience in the feeding of Rhodes-grass hay in this country to make a definite statement regarding its feeding value, there remains little doubt in the minds of those who have fed it on a small scale that it is equal to any of the grass hays. Its chemical analysis points to a high nutritive value, and its aroma and palatability are such as to make it readily eaten by stock. The color and texture give the hay an attractive appearance. These qualities aid materially in establishing it as a staple on the city markets. The yield afforded by Rhodes grass is one of its strong points. In this respect it has more than come up to expectations. Even on poor, sandy soils it frequently produces two or more cuttings per season exceeding  $1\frac{1}{2}$  tons each. On good soil or on land that has been well fertilized yields much in excess of this are obtained. There are authentic reports of total yields per season of 6 tons per acre of well-cured hay secured from three cuttings, the first cutting being made in May, the second in July, and the third in September. (See Pl. LXVII, fig. 1.) At the present market price of hay in the South it can be easily seen that such yields are very profitable.

## CULTURE OF RHODES GRASS AND THE AREA TO WHICH IT IS ADAPTED.

The culture and general management of Rhodes grass as a hay crop have not yet been well worked out, but there seems to be comparatively little difficulty in securing a stand, and very little evidence that the grass will need any special treatment. The point in its culture that will need attention, however, is the harvesting of seed. This can not be done as easily as in the case of timothy, orchard grass, or redtop, since the seed ripens unevenly and shatters from the seed head shortly after maturity. In Australia, where the seed is now on the market, it is mostly harvested by hand, but there is little doubt that a much less expensive method will be developed as soon as the occasion demands.

At the present time Rhodes grass can hardly be recommended for sections other than Florida and portions of the immediate Gulf coast region, as it is killed during the winter by temperatures of approximately 20° F. In sections having temperatures as low as this it can not be depended upon as a perennial, and with the present high price of seed it would hardly be profitable to sow it each season. After its culture has been well worked out, it is quite possible that a method will be developed whereby the grass will be handled in a manner to reseed itself. If this condition obtains, or if the seed becomes sufficiently cheap, it can be grown considerably north of Florida as an annual crop. The area over which Rhodes grass can be grown as a perennial crop, however, is sufficient to make the grass a recognized hay crop in this country, provided it fulfills its present promises.

It is perhaps a little too early to predict the outcome of the introduction of this grass in the United States. Many drawbacks to its culture may develop that can not now be foreseen. Insect enemies and diseases may appear and retard the growing of it on a large scale, and there is, of course, a chance that the results obtained from tests have been greatly overestimated. However, unless some handicaps do obtain, it is reasonably expected to see within the next few years large farms devoted to the growing of Rhodes-grass hay and hay farming, replacing, in many instances, the type involving the growing of perishable crops.

## SUDAN GRASS AND TUNIS GRASS.

Probably of greater importance than the introduction of Rhodes grass is that of Sudan grass, and possibly one of its close relatives, Tunis grass. Regarding the possibilities of the latter, however, very little can be said, since it has been tested in this country to only a limited extent; while the widespread manner in which Sudan grass



has been tried gives quite a definite indication of the place this grass may be expected to fill in our agriculture.

There seems to be comparatively little known regarding the history of the cultivation of Sudan grass, due partially to the confusion in literature concerning its identity, but probably more to the fact that it has never been grown extensively under cultivation.

Even less is known regarding the cultivation of Tunis grass, the accounts of it being extremely brief and more confused than those of Sudan grass.

Like Rhodes grass, these grasses were introduced from Africa, where apparently they are native, and, while there is no positive proof that this is the case, the evidence is quite convincing, as they do not seem to be found growing naturally in any other part of the world. The evidence is further strengthened by the fact that Africa is the home of many representatives of the general group sorghum, to which they both belong.

#### THE SEARCH FOR INTERMEDIATE FORMS.

Being convinced that there must exist forms intermediate between Johnson grass (*Andropogon halepensis* Brot.) and the cultivated sorghums (*Andropogon sorghum* Brot.), Mr. C. V. Piper, of the Office of Forage-Crop Investigations, instituted a search for the same through the Office of Foreign Seed and Plant Introduction. As a result several lots of seed were secured, some of which were said to be from plants having the above characteristics, but only two of the grasses merit consideration at this time. To these the names "Sudan grass" and "Tunis grass" were applied. The Sudan grass was obtained from Mr. R. Hewison, director of agriculture, Khartoum, Sudan, March 16, 1909, under the botanical name *Andropogon halepensis*, and the vernacular name "Garawa." This importation was assigned S. P. I. No. 25017. Mr. Hewison furnished at that time no information other than the common name of the grass.

Shortly after the introduction of Sudan grass, December 2, 1909, there was received from Dr. L. Trabut, Algiers, Algeria, under the name *Sorghum halepensis virgatus*, a packet of seed of what was later called "Tunis grass." With the seed Dr. Trabut submitted the following information:

This grass is vigorous, but not stoloniferous, and would be interesting for hybridizing with *Sorghum vulgare* (*Andropogon sorghum*). Like Johnson grass, it is a moderately good forage, but it has the advantage of not stooling. This variety is perennial here and produces many seeds.

The packet of seed from Dr. Trabut was given S. P. I. No. 26301, and the above note recorded with it.

On being tested these two grasses proved to be quite different in general habit of growth and also in certain seed characteristics, the Tunis grass being apparently the more primitive of the two.

## BOTANICAL RELATIONSHIPS.

From a botanical standpoint alone Sudan grass and Tunis grass are extremely interesting, since they indicate the possible origin of the cultivated sorghums, resembling on the one hand Johnson grass in organization and vegetative characters, and to a similar degree the cultivated sorghums on the other. That they are primitive forms of sorghum can scarcely be doubted when their characters are carefully studied; and that they are more closely related to the sorghums than to Johnson grass is indicated by the fact that neither possesses underground rootstocks. The details of the relationship of these groups, however, will not be discussed here, nor will an attempt be made to settle the questions of nomenclature that are involved, other than to state that Sudan grass, at least, is botanically *Andropogon sorghum*, and not *Andropogon halepensis*, as it was formerly called.

## POSSIBILITIES OF TUNIS GRASS.

At this time it is unnecessary to enter into a discussion of Tunis grass, as the tests with it have not advanced to the stage where definite conclusions regarding its value as a forage crop can be reached. It is mentioned here because of the possibilities which it possesses and because of its relationship to the sweet sorghums, Johnson grass, and Sudan grass. While it is really a promising grass, it is somewhat doubtful whether it has any marked advantages over Sudan grass. As the tests now stand, it appears to be inferior to the latter in seed habit and in quantity of growth, but it produces a finer growth, and in this respect may have the advantage of being more easily cured and handled as hay. (See Pl. LXVII, fig. 2.)

## CHARACTERISTICS AND POSSIBILITIES OF SUDAN GRASS.

Notwithstanding the fact that only a small quantity of seed of Sudan grass was originally received, preliminary tests were so satisfactory that as little time as possible was lost in growing a supply for extensive trials. Those who saw it in the field were convinced of its possibilities, and as a result it is now (four years after its first introduction) remarkably popular and ready for a permanent place among our forage crops.

In the matter of habit Sudan grass has many advantages over both the sweet sorghums and Johnson grass, being finer in growth and more leafy than the former, and without the rootstocks which make the latter so troublesome and unpopular in many sections. It also has other advantages. It is easily cured and easily handled as hay and is very drought resistant. In all of these characteristics it is much superior to sorghum, and in yield, drought resistance, and palatability it appears distinctly to outclass Johnson grass. Sudan grass

is strictly an annual in this country, although it occasionally shows a tendency to perennate in the extreme South, as do certain of the sorghums. Reports from Sudan regarding this character are rather indefinite; however, it is undoubtedly not a true perennial even there. The abundance of seed which it produces makes the use of Sudan grass as an annual practical over a large area, for not only is the seed produced plentifully, but it is easily harvested and can be sown without difficulty. While it is unquestionably better adapted to the South, generally speaking, than to the North (it being an annual), it is not limited in its area by temperature, as is Rhodes grass, but can be grown successfully in many of our Northern States. Although its range of adaptability is great, results up to the present time indicate that its area of greatest importance will probably be the drier portions of Texas, Oklahoma, and Kansas. Here it thrives admirably on comparatively little rainfall, and is, in general, a more satisfactory forage crop than the sweet sorghums or the millets. From Texas, especially, the reports regarding it have been uniformly optimistic. In this State two or more cuttings of hay are secured during a season, and the yield of each is above that of either millet or Johnson grass.

A nonleguminous crop that can be grown satisfactorily in combination with cowpeas for hay and silage has long been sought for. The sweet sorghums and millets have not fulfilled the conditions, the general objection to these being that the former is too coarse and the latter too fine. Sudan grass seems to meet the requirements. Its rate of growth, size of stem, and curing qualities make it almost ideal for use in mixtures with either cowpeas or soy beans. Tests of such mixtures were conducted at the Arlington Farm, Va., during the past season, and the results obtained were most satisfactory. In mixtures where 60 pounds of cowpeas and 20 pounds of Sudan-grass seed were sown per acre, approximately one plant of cowpeas to three of Sudan grass resulted, making an excellent combination for hay. A mixture of the same proportions with soy beans substituted for cowpeas produced a crop of hay of high quality and heavy yield. In this series of tests Sudan grass proved much superior to Amber sorghum, Johnson grass, or millet.

That its range of adaptability might be approximately determined, the Department of Agriculture distributed seed in small quantities to a large number of State experiment stations. The reports from these tests are in most cases very gratifying. Notwithstanding this, it can hardly be expected that Sudan grass will become a popular crop in all sections where it has been reported upon favorably, since in many of these there are other valuable and highly satisfactory forage crops already well established. It is where the need for good forage crops is great that it will probably be commonly used.

## CULTURAL METHODS.

There still remains much to be determined regarding the best methods of growing Sudan grass. Several satisfactory ones have already been developed, the most promising being that of planting in closely cultivated rows in which the seed is sown thickly. (See Pl. LXVIII, fig. 1.) While broadcasting also gives good results, it does not seem to produce the yields that are obtained from cultivated rows, even under conditions of ample rainfall. An 18-inch row can be easily cultivated once or twice while the grass is young, and after it has attained a height of 2 feet or more additional cultivation does not appear to be necessary, either to keep down weeds or to promote further growth. For the production of seed, which is an important consideration at this time, the cultivated row is unquestionably to be preferred to broadcasting. It not only greatly increases the yield, but also facilitates harvesting. The yield of hay and seed from Sudan grass can as yet be only roughly approximated. Suffice it to say that in a vast majority of the cases reported the yield of hay has been unusually high and that of seed entirely satisfactory.

The reasons for predicting widespread popularity for this grass are based on its wonderful adaptability to various conditions, its ability to produce under these conditions profitable yields of excellent forage, and the ease with which it can be grown. With the numerous advantages which Sudan grass possesses, it promises to compete in a measure with Johnson grass in parts of the South, and generally with the sweet sorghums and the millets.

## SUDAN GRASS SEED.

That there may be no misunderstanding regarding the resemblance of Sudan grass to Johnson grass, it must be distinctly understood that while the former is much the same as the latter in appearance, Sudan grass under no conditions produces rootstocks, and is at once eradicated by plowing. (See Pl. LXIX.) The question may arise as to whether, on account of the close similarity of the seed, Johnson grass may not inadvertently or otherwise be introduced by means of Sudan grass. This is entirely possible, but it can be obviated by sowing seed that is produced only in the North, where Johnson grass is not grown. At this stage, when the seed of Sudan grass is scarcely a commercial commodity, extreme caution should be used, as unscrupulous dealers will be inclined to adulterate it with seed of Johnson grass. Such a practice, however, will unquestionably fall into disuse in a comparatively short time, as the seed of Johnson grass will undoubtedly soon be the more expensive of the two. Seeds of these grasses may be quite readily distinguished after a little experience, those of Sudan grass being plumper than

those of Johnson grass and breaking from the seed head or panicle with a small portion of the rachis or branch. The seed of Johnson grass breaks off smoothly with a well-defined scar, and in this respect Tunis grass is quite similar to it. (See Pl. LXVIII, fig. 2.)

HYBRIDIZING WITH CULTIVATED SORGHUMS.

Owing to the close relationship between Sudan grass and the sweet sorghums, natural hybrids between them are abundantly produced where they are grown in close proximity to each other. A number of these hybrids have been isolated by the department and are quite promising. (See Pl. LXX.) For the present, however, it is advisable to keep the two crops separate and to rogue out any variations that may appear in the Sudan-grass fields in order that the true type may be maintained.

Sudan grass already needs no exploitation, and it hardly seems likely that anything will develop to detract from its popularity or to lessen its usefulness. Numerous representatives of its group (the sorghums) are now, and have been for a long time, important forage crops in this country. Taking this into consideration, together with the wonderful showing Sudan grass has made, the predicting of a bright future for it seems entirely justified.

# RAISINS, FIGS, AND OTHER DRIED FRUITS AND THEIR USE.

By C. F. LANGWORTHY,

*Chief of Nutrition Investigations, Office of Experiment Stations.*

## INTRODUCTION.

In discussing the food value of fresh fruits the common varieties are frequently divided into two groups—those whose water content is so high that their value lies mainly in the pleasant flavor and healthful variety that they give to the diet and those which contain sufficient quantities of nutritive ingredients to add noticeably to the food value of the total diet. Roughly speaking, those whose water content is 80 per cent or over are classed as “flavor fruits.” This class includes the majority of our common fruits, e. g., apples, pears, peaches, plums, oranges, most berries, etc. The banana is perhaps the most often called a “food fruit,” that is, one whose water content is less than 80 per cent, but grapes, figs, and olives are other well-known members of the group. When dried fruits are under consideration this distinction between flavor and food fruits disappears. The amount of water in dried fruits depends upon the degree of desiccation rather than upon the original composition of the fruit, and the latter is therefore no guide to the food value of the dried product.

Of course the flavor of dried fruits is almost never the same as that of fresh fruits; for eating in the simple state, and for some, though not all, cooking purposes, fresh fruits would usually be preferred were they equally convenient. As everyone knows, fresh fruit will not keep indefinitely, even with the most careful storage, and it is, moreover, so bulky that shipping it from place to place and providing storage room is decidedly expensive. Drying has the double advantage of protecting against decay and rendering the fruit more compact, while at the same time a product results which is palatable and convenient. A pound of fresh fruit will yield an average of about 6 ounces dried. The food value of a pound of dried fruit is, of course, greater than that of the same weight of fresh, since it has been concentrated by evaporating the water originally present.

The main change which takes place during drying is a loss of water, but other changes also occur, their nature varying greatly with different kinds of fruit and with different methods of drying, particularly with the degree of heat employed. Very often the right

degree of heat produces changes not unlike those which occur during natural ripening on the plant. In general the carbohydrates which make up the largest part of the solid matter of the fruit undergo the most extensive changes. In some cases the crude fiber, which forms the basis of the plant structure, is reduced in amount or softened. Much of the starch is changed to some form of sugar, and the less soluble sugar may be reduced to more soluble forms. The change in flavor is due partly to the proportionate increase of sugar from loss of water and absolute increase from the chemical changes just referred to; partly to the fact that some of the volatile oils and other ethereal bodies, which give the distinctive flavors to fresh fruits, pass off or are modified during the drying process; and partly to a lessening or masking of fruit acids and to certain chemical changes in the tannin by which its characteristic "puckery" flavor is lessened and by changes in other substances of the fruit.

Dried fruits probably first appeared in warm countries, but they have long been known among the peoples of northern latitudes. Certainly in America the practice of drying fruits has been common ever since the first settlements by Europeans. Dried apples and berries played a prominent part in winter menus of colonial times, as they had in the winter supplies of the Indians, though the methods of drying were crude and the dried fruit often poor and irregular in quality. Of recent years the rapid improvement in machinery and methods of drying have given a great impetus to the dried-fruit industry, and artificial drying produces so much better results that it has very largely superseded the old-fashioned methods for apples, apricots, peaches, and most of the fruits grown in the northern parts of this continent and Europe. The cost of fuel and equipment is more than offset by the economy of time and labor, to say nothing of the greater cleanliness and uniformity of the fruit so prepared. Artificial drying is usually practiced on so large a scale that it is economical to have special rooms or apparatus for each part of the process, and this eliminates much of the handling and exposure to dust and dirt and insects, which were likely to make fruits dried by the old-fashioned methods so unattractive or even unhealthful.

Questions of fruit production and preservation have been studied, with very important results, by the Department of Agriculture and the agricultural experiment stations. To this work and the efforts of the American fruit growers may be attributed the great development of the dried-fruit industry in the United States in recent years.

#### THE PREPARATION OF DRIED AND EVAPORATED FRUITS.

Drying, evaporating, and desiccating are all terms used to describe the making of the fruit products under consideration. There are no

very definite distinctions which can be drawn between fruits prepared by such processes, though perhaps "dried fruit" is the broadest term. Removing the water depends chiefly on heat and the pressure and water content of the air surrounding the fruit and the rapidity with which the air circulates. The lower the air pressure, the drier and the warmer the air, and the more rapidly it moves, the more easily the fruit will give up its watery juice. If the process of drying is too rapid or too slow, or if the degree of heat is too great or too little, the resulting product will be below standard. The different methods and devices for preparing dried fruits have resulted from a recognition of such facts and an attempt to apply them accurately. The liking for one or the other is a matter of personal preference and habit, but the rapid drying achieved by modern methods gives a superior product of different flavor as well as of different color and texture from the old-fashioned home-dried fruit.

From the point of view of those who finally eat the fruit, the main thing is to have it dried in such a way that it shall retain as much of the natural flavor and food ingredients as possible, together with soft texture, attractive appearance, good keeping qualities, and freedom from insects or dirt or harmful substances of any kind.

For some kinds of fruit, especially for raisins and figs, artificial drying does not work as well as sun drying. The great difficulty with natural drying in the open air, aside from the uncertainty of the weather, is, of course, the exposure to dust and insects. Everyone knows that dust may be the bearer of all sorts of microorganisms, causing disease, and of other tiny organisms which cause decay in the fruit. Insects, attracted by the sweet fruit, introduce future worms by laying their eggs in it. It is possible to guard against these dangers by choosing clean and protected drying places, by preventing careless and unnecessary exposure, by washing or sterilizing, and by careful packing and marketing. The large establishments in the fruit-growing sections of the United States are setting high standards of cleanliness and are demonstrating that it is profitable to produce really sanitary goods. Unfortunately such conditions do not prevail in some of the countries around the eastern end of the Mediterranean, from which comes such a large part of the world's dried figs and dates.

Preparing dried fruits for the market is a more complicated process than is commonly realized. The modes of procedure naturally vary in different localities and for different kinds of fruit, but they can all be shown to depend on scientific principles, even though those who apply them may not have taken this into account. The housekeeper who dried her own apples may not have understood that the tannin present in the flesh of fruit is acted upon by oxidases when exposed to the air, or that salt inhibits such action, but she knew that the



sliced fruit would turn brown unless she put it into cold water, or, better still, into salted water. The Chilean farmer who digs a hole and burns sulphur in it under the peaches he is preparing to dry probably does not realize that the fumes of sulphur check enzymic action and kill microorganisms, but he does know that if the smoking is omitted his fruit is likely to lose its good color, turn sour, and breed worms. The producer who understands the scientific reasons for all these processes has the advantage of being able to apply them more accurately and economically, and thus to get a better and more uniform product even when crops and weather conditions are poor.

Most fruits are dried without the addition of any foreign substance, save the negligible amount of salt or other material which may be used in washing them. In some cases, however, sugar is added, and the fruit so prepared is usually called "candied" or "crystallized." The chemical principle here is exactly the same as in preserving fruits in sirup, namely, that the microorganisms which might produce decay do not develop in the presence of large quantities of sugar. Candied fruits are practically fruits which have been cooked in sirup until they have taken up all the sugar which they are capable of holding and dried until all free moisture has been removed. They are, of course, much richer in sugar than the fresh fruit or ordinary dried fruit. If well prepared, they retain the delicate, natural flavor better than those dried without sugar, and often also the original shape and color. This means complicated processes and skillful workers, and the best candied fruits are therefore relatively rather expensive and looked upon as sweetmeats and garnishes rather than as staple foods.

The old-fashioned fruit "cheeses," or "marmalades," as they are sometimes called (apple, quince, etc.), made from fruit pulp and sugar, sometimes seasoned with spice, are palatable dried-fruit products. A similar commercial product is guava paste. To the list may be added jelly, which is, of course, fruit juice evaporated with sugar.

#### EXTENT OF THE USE OF DRIED FRUITS.

There are no figures available to show the consumption of dried fruits in this country; but by taking the statistics of production as given in reports of the United States census and comparing them with the tables of exports and imports prepared in the Bureau of Statistics of the Department of Agriculture, one can get at least an approximate idea of conditions. In 1899 the amount of dried fruit produced in the United States was about 85,000,000 pounds and in 1909 about 484,000,000 pounds, an increase of 575 per cent. The value of the products rose from \$4,757,005 to \$21,914,995, and the average wholesale selling price dropped from about 5½ cents to about 4½ cents per

pound. Of all the dried fruit produced in the United States in 1909, 83.1 per cent came from California. Unfortunately, statistics of total exports and imports have not been prepared for fresh and dried fruits separately, but from data at hand it may safely be inferred that in 1909 the exports exceeded the imports by at least 20,000,000 pounds. According to this very rough estimate each person in the United States consumed on an average of 5 or 6 pounds of dried fruit a year.

#### DRIED APPLES AND PEARS.

Of the fruits commonly dried in this country apples were formerly by far the most important in amount, but while the quantity produced continues to increase slowly, raisins, prunes, and peaches have jumped ahead in the list during the last few years. Practically no dried apples are imported. In 1909 about three-fourths of the annual output of 44,000,000 pounds was exported, leaving only about 11,000,000 pounds for home consumption. This relative falling off of the importance of dried apples is mainly due to the fact that methods of storing the fresh fruit have been so greatly improved that it is available at reasonable prices for a much longer season than formerly. The improved quality of dried peaches and apricots has very likely further decreased the popularity of apples.

The complicated machines which peel, core, and sometimes even slice the apple at one operation are in very general use. After the fruit has been thus prepared it is usually dipped for a few minutes in a weak solution of salt and water. The purpose of this dipping is to prevent the discoloration which ordinarily occurs when the flesh of the apple is exposed to the air. After dipping, the apples are commonly placed in the drying trays, in which they are later taken to the drying machine. Many manufacturers subject them at this stage to a short fumigation with sulphur, the purpose of which is to make the color lighter and to kill any moth eggs or injurious micro-organisms which may be present in the fruit. Sulphuring, which is used with various kinds of fruit, is in this country carefully regulated by law. The actual drying process varies in different establishments. Perhaps the most common is one in which hot air under high pressure is passed over the fruit. From 6 to 8 hours is perhaps the usual time required. The temperature must be carefully regulated so as not to burn or harden the fruit, which when dried should be soft and pliable. On being removed from the desiccator the fruit is allowed to stand for what is known as the "sweating" to take place, a process which usually takes several days, and is carried out either in the open air or in well-ventilated chambers. The dried fruit should be packed and marketed in ways which keep it clean and unspoil.

Pears are seldom dried in this country, but are often so preserved in northern Europe, where winter fruits are scarce. Before being dried they are usually dipped in lye to loosen the skin, which is then rubbed off by hand. They are cored, halved, and then treated like apples. Pears are also candied, usually in quarters or smaller pieces.

#### PRUNES, PEACHES, APRICOTS, AND CHERRIES.

The increase in the production of these dried fruits in the United States during the last few years has been very rapid, nearly nine times as many pounds of peaches and between five and six times as many apricots and prunes being dried in 1909 as in 1899. Almost no dried apricots and peaches are now imported, and the prunes received from foreign countries are mainly expensive fancy grades. The increase in exports keeps pace with the production. According to available statistics, about 12,000,000 pounds of dried apricots, 44,000,000 pounds of dried peaches, and 115,000,000 pounds of prunes were consumed in the United States in 1909. All of these fruits belong to the same botanical class and are dried in about the same way. Prunes, which, as everyone knows, are dried plums, being the most common, a somewhat full description of the way in which they are desiccated will serve to show how all of the class are handled.

The United States, especially California and Oregon, are fast becoming the chief prune-producing regions of the world. Those next in importance are the Balkan States and France. The harvesting is very carefully done in the best orchards, the fruit being picked by hand or gently shaken upon sheets spread under the trees. Unless the plums are perfectly ripe, the picked fruit is allowed to stand in the sun for a day or two, in order that its natural sugar content may be increased and the water lessened. It is then graded according to size, in order to make the drying more uniform, the larger specimens of course requiring a longer time than the smaller. The next step is intended to clean the fruit and so to treat the skin that the water will be more quickly evaporated from the interior. Sometimes both of these ends are attained simply by dipping the fruit into boiling water. More often, however, this water bath is supplemented by pricking the skins with special apparatus or the fruit is dipped into hot lye, which both cleans the exterior and very slightly cracks the skin. Where the climate allows, prunes are sometimes dried in the open air, or in simple drying sheds, but most commonly artificial heat is used to hasten the process. Sun drying in California usually requires from 1 to 2 weeks and artificial drying, by the common American method, from 24 to 48 hours, according to the character of the fruit. Like apples, the dried prunes are

“sweated” for 2 or 3 weeks and then regraded according to the number required to make a pound. The largest and best quality prunes give from 20 to 30 per pound, and the grades run from this down to 100 or 120 per pound. After grading they are finished or “glossed” by heating in steam or immersing in salted boiling water, fruit juice, or glycerin. This process sterilizes the exterior and gives the shiny surface which many persons consider a mark of good fruit.

Another dried plum long imported into the United States, though not in large quantities as compared with prunes, is the prunello, a small, rather acid plum of yellow color but pleasing flavor, pitted before drying, and used in much the same way as dried apricots or dried peaches.

Peaches and apricots are ordinarily pitted before drying. Like plums, the fruit should be carefully picked to avoid bruising and promptly prepared for drying. Peaches are sometimes peeled, in which case they are usually dipped in hot lye to loosen the skins. Apricots are practically always dried with their skins on. After cutting and pitting, the fruit is laid in trays, skin side down, and if sulphuring is practiced it takes place at this point. Then follows the drying proper. Dried peaches and apricots are usually packed in layers in wooden boxes and marketed without further treatment.

Peach and plum leather represent a household method of drying such fruits which, though not so common as in former years, is still well known in the southeastern States. The fruit is peeled, pitted, mashed, spread out in a thin layer, and then dried in the oven or in the sun until the mass is tough and resembles leather in appearance. It is said to keep indefinitely, even if only packed in bags.

Apricots, peaches, and plums are often candied according to processes already referred to. Cherries are especially popular in this form. They are esteemed for their color quite as much as their flavor and, as the former is quite likely to be weakened by the heat of cooking, dyes are not infrequently used. Our National and State pure-food laws prohibit the use of harmful coloring substances in this country and regulate the whole matter of the use of artificial colors.

Housekeepers sometimes preserve stone fruits by a method which represents a sort of cross between candying and ordinary drying. The pitted fruit is sprinkled with sugar, placed in a moderate oven until it is hot, and then dried slowly in the sun or in a cool oven.

#### RAISINS, “CURRANTS,” AND DRIED BERRIES.

Raisins, Sultanas, and dried English or Zante currants are all made by drying special kinds of grapes. The varieties used for raisins are more like the thin-skinned Malaga grape than like the American Concord, which has a thicker skin with a layer of pulp

adhering to it. There is some popular confusion between small-sized raisins and so-called dried currants. The small light-colored raisins known as "Sultanas" are made from a small, white, seedless variety of grape. What are known in the trade as "Corinth," "Zante," or "English" currants are really small varieties of grapes grown originally and principally in southern Greece.

The old nursery rhyme with its refrain of "Malaga raisins, the very best raisins in town," indicates from what part of the world high-grade fruit was formerly imported. Spain still sends more raisins (exclusive of the so-called currants) to the United States than any other country, but Asiatic Turkey is not far behind it. Greece supplies nearly all the imported Zante currants, which amount to ten times the importation of the other dried grape products. This does not mean that raisins are not being used, but that as the raisin industry develops in California the importation of raisins is falling off rapidly, the American fruit being given the preference. The amount of raisins produced in this country rose from 15,000,000 pounds in 1899 to over 195,000,000 pounds in 1909. In fact, the United States is now exporting more raisins than it produced in 1899.

The method of curing the grapes depends somewhat upon the purpose for which the raisins are intended. The smaller varieties, and some of the larger grapes, are used for making raisins for cooking purposes, whereas only the best quality fruits from the larger varieties can be made into satisfactory table or layer raisins. For the latter the bunches are first carefully picked over to remove dried or unripe berries and are then placed on trays in the sun. It usually takes two or three weeks to cure the raisins, but in damp weather the process will have to be continued longer. The less handsome bunches of grapes of the larger varieties and the smaller Sultana and the currant kinds, which are intended for cooking purposes, are dipped in weak lye before they are dried. The purpose of this is to soften the skins slightly and loosen the stems, which are removed before the raisins are packed. California packers have produced brands of seeded raisins in which the berries have been cut open and the seeds removed; they are tightly packed in cartons and are undoubtedly very convenient in household use.

In olden times strawberries, raspberries, blackberries, blueberries, barberries, currants, in fact most native small fruits, were frequently dried at home for use during the winter months. Now that fresh and preserved fruits are so much more abundant, this practice has very greatly lessened. It still exists in a few regions, such as the mountains of Tennessee, where dietary studies made by the Department of Agriculture showed such dried fruits to be staple foods.

Housekeepers frequently used to sprinkle sugar over their berries and heat them slightly before drying. The practice still followed in

parts of New England of drying raspberries with maple sugar is interesting as a survival of the former custom of using maple sugar in the place of cane sugar, and shows how chance may point the way to good combinations of flavor.

#### CITRON AND OTHER CITRUS FRUITS.

Various fruits of the citrus group are sometimes used in the commercial article called "citron," but the one to which the name properly belongs and which is the standard for quality is the citron (*Citrus medica macrocarpa cedra*). This is grown to a very limited extent in California, but the great bulk of the world's crop comes from the Mediterranean countries. The fruit is similar in shape to a lemon, but larger, usually weighing 3 pounds or more, and has a thicker skin and a smaller proportion of pulp. The oil in the skin is of such flavor that it is necessary to extract it with brine before the fruit is ready for crystallization, a process usually lasting about three weeks. The fruit is then boiled to remove the salt and to loosen the pulp, which is scooped out with a spoon. The candying was formerly done by boiling the fruit in a solution of ordinary sugar, but it is now claimed that cane sugar alone causes it to crystallize too completely and to become too brittle, and that a softer, more translucent, and better flavored product can be obtained by using a limited amount of commercial glucose along with the cane sugar. The fruit is boiled in the sirup for an hour and then allowed to stand for about a week. The process is repeated until the fruit has absorbed all the sugar it can take up. It is then allowed to stand in the sirup for about a month and is finally boiled in a pure cane-sugar sirup, which gives it a crystallized coating or gloss. It will then keep indefinitely and is ready for packing and shipping.

Certain varieties of melons are used to make an imitation citron. These are candied in much the same way as true citron. Their flavor and texture are not the same, but they are rather cheaper and, if sold under their proper names and not as true citron, there can be no objection to them as commercial products, while they are often a convenience to the housekeeper who can grow and prepare them at home.

Orange, grapefruit, and lemon peel are also crystallized at home, or by confectioners, but usually by quicker methods which do not saturate the fruit with sugar so completely as citron. A small orange-like fruit called "kumquat," which, since its introduction into Florida and California, is rapidly gaining favor in American markets, has long been imported from China in crystallized form and may be so prepared at home. All these and similar products are used either by themselves as sweetmeats, or to flavor or garnish cakes, puddings, etc.

## DATES.

The date is ordinarily associated with desert countries and is a staple food in Northern Africa and Western Asia. A hot, dry climate is important for its growth, not so much because the trees are extremely sensitive to cold as because it is impossible to prepare the fruit by natural methods without heat and dryness at the time of harvesting. The ripe date is naturally rich in sugar and contains so little water that it does not require drying like the more juicy fruits. If the weather is moist when the ripe fruit is gathered, it is almost sure to ferment and a large proportion of the crop is often lost.

The speed with which ripening takes place, and the relative proportion of cane and invert sugar present at different stages of development, vary with the varieties of fruit. The more invert sugar present, the softer and more translucent the date and, as a general rule, the richer the flavor. Soft dates rich in invert sugar would, therefore, be by all means the most desirable were it not for the fact that they are sometimes sticky, hard to handle, and somewhat susceptible to decay. The dates rich in cane sugar, on the other hand, are dry and easily handled, but rather hard and comparatively tasteless.

The American imports come largely from the eastern end of the Mediterranean, 26,000,000 of the 29,000,000 pounds received during 1911 having been shipped from Asiatic Turkey.

The date palm has been introduced into the United States and its fruit has been found to ripen well in Arizona and neighboring regions. The American date is at present an experimental rather than a commercial product, but the results already obtained indicate that there may be a great future for this industry. The Arizona experiment station, cooperating with the Department of Agriculture, has carried on elaborate investigations regarding date curing. American dates are graded according to size and quality. The finest specimens are attractively packed in small boxes and bring high prices in the fancy-fruit markets of the United States. The second grade of dates is pressed in layers in larger boxes, to be retailed either by the box or by the pound. Their appearance is usually so much superior to that of the imported Mediterranean dates that dealers have no difficulty in retailing them at prices 5 cents or more a pound higher than those obtained for the imported article.

## FIGS.

The fig tree may be grown in almost any mild climate, but the varieties with fruit suitable for drying can be produced only under special conditions. Practically all the dried figs of European commerce come from the hot countries bordering on the Mediterranean,

and especially from eastern Turkey. The great dried-fig district of the world is a strip of land near Smyrna, 90 miles long and from one-half to three-fourths of a mile wide, from which 13,000,000 pounds were imported into the United States in 1909, the total imports of figs into this country during that year being only about 15,000,000 pounds. The methods of preparing the fruit for market are so crude and primitive that they leave much to be desired on the grounds of cleanliness, or even healthfulness.

The climate of California is well fitted to the development of the fig industry, and fresh or table figs have long been successfully produced there. For years, however, it was impossible to develop a really satisfactory drying fig, mainly because of the difficulty in fertilizing the Smyrna fig. This has finally been accomplished, and the California dried-fig industry is growing very rapidly. Great precaution is taken by the California fig growers to make the fruit uniform and free from all forms of uncleanness. The figs are washed in salt water before drying, and again after the drying is almost completed; they are very carefully graded and packed with as little handling as is consistent with a careful product, and, thanks to their clean and attractive appearance, are rapidly gaining a hold on the American market.

#### BANANAS.

Common as is the fresh banana in American markets, it is rarely seen here in any other form, but preparations of dried bananas are common in the countries where the fruit grows. Many varieties not suitable for ordinary transportation can be dried in their ripe state, when their best flavor is fully developed. The peeled fruit is quartered, or cut into some other convenient form. The larger pieces of dried banana are sometimes marketed under the name of "banana figs" and are used in much the same way as dates, figs, and raisins in preparing a variety of dishes. Sometimes the ripe fruit is passed through a sieve and the pulp dried in small cakes. Other kinds of dried banana goods have also been put on the market at different times. Owing to the large yield of fruit and their high carbohydrate (sugar and starch) content, bananas have long been recognized as a very cheap food, and considerable effort has been made to introduce the dried forms into northern countries. More success has, so far, been made in Europe than in the United States, but it seems likely that the value of these new preparations will be better appreciated as they become better known.

#### COCONUT.

The white meat in the interior of the coconut seed, technically known as copra, is used not only for the extraction of oil but in the



better qualities for the preparation of what is commonly called desiccated coconut. After the proper amount of water has been extracted the dried coconut is shredded or ground and packed, usually in small cartons, for the retail market. Sometimes in the Tropics coconut is dried with brown sugar, making a sort of confection which is much liked. Coconut forms a staple of diet in lands where this palm flourishes, but in the rest of the world it is used mainly for flavor and garnish in connection with other foods.

#### LESS COMMON DRIED FRUITS.

Other dried fruits less well known, though some of them are used in fairly large quantities, are ripe olives, salted and dried, imported to the United States from eastern Mediterranean region, where they are eaten as a staple food; dried cactus fruit, used in southwestern United States and in Mexico and Mediterranean regions; dried mangoes, a Mexican product, which seem promising, though little known at present; dried native persimmons, an old-fashioned domestic product, somewhat like the date in flavor when of good quality; and Japanese persimmons, an important foodstuff in Japan, now being studied experimentally by the Bureau of Chemistry of the Department of Agriculture, and a very promising addition to our food supply.

A product of importance is the dried chestnut, so much used in European cookery and now fairly common in the United States.

From China comes the litchi nut, or Chinese raisin, common in American markets wherever there are Chinese. The jujube from the Old World is little known in the United States, except in the form of jujube paste, an old-fashioned but popular kind of candy. To the list may be added also the carob bean, or St. John's bread, the dried pods of a European locust liked, on account of its licoricelike flavor, by children, particularly those whose parents came from parts of Europe where it is a common article of commerce.

#### THE FOOD VALUE OF DRIED FRUITS.

The nutritive value of dried fruits, like that of other foods, depends primarily upon the proportion of the various food ingredients which they contain. In general, the food value is higher the lower the water content. It is for this reason that the dried fruits which, according to analyses, contain from about 15 to 30 per cent water are so much more nutritious than fresh fruits, with averages of from 75 to 95 per cent. The total edible portion of a typical dried fruit such as the raisin contains on an average 3 per cent protein (nitrogenous material), 3 per cent fat (chiefly vegetable wax), 76 per cent carbohydrates, and 3 per cent ash, in addition to 15 per cent water, the average fuel value being 1,605 calories per pound. Ripe grapes

before drying have been found to contain on an average 77 per cent water, a little more than 1 per cent protein, 2 per cent fat, 19 per cent carbohydrates, and less than 1 per cent ash, the fuel value being 450 calories per pound. Dried apples on an average have been found to contain 2 per cent protein, 2 per cent fat, 66 per cent total carbohydrates, and 2 per cent ash, in addition to 28 per cent water, and to have a fuel value of 1,350 calories per pound. According to numerous analyses fresh apples contain on an average 85 per cent water, 14 per cent carbohydrates, less than 1 per cent each of protein and fat, and less than 1 per cent ash, the fuel being 290 calories per pound.

Other dried fruits have much the same composition as those cited and differ from the corresponding fresh fruits in a similar way.

Most vegetable foods as purchased contain a larger or smaller amount of inedible material, such as skins, cores, stems, etc. The seeds of dates, plums, raisins, etc., are practically the only refuse in the case of dried fruits, and as many dried fruits are seeded before the process of manufacture the refuse is reduced to a minimum in this class of food products. Of the 1 or 2 per cent acid found in such fresh fruits as apples, pears, plums, berries, etc., the greater portion remains in the dried fruit, though it may not be so noticeable, being masked by the sugar present. Dried fruits show a considerable range in composition, while the different sorts vary among themselves, as do the fruits from which they are made. Making due allowance for such facts it may be said that the figures given above represent fair averages, and that raisins, dates, and figs have on the whole a lower water content than dried apples, peaches, and prunes. Conversely, they contain larger proportions of nutrients. The difference in the amounts of protein, fat, and carbohydrates furnished by the different kinds is on the whole too slight to be of importance in the ordinary mixed diet.

As compared with simple dried fruits, candied or crystallized fruits ordinarily have a lower water content and contain larger amounts of carbohydrates, the latter due mainly to the added sugar.

The food value of nearly all vegetables and fruits lies mainly in the sugars and starches which are commonly grouped together by chemists under the head of "carbohydrates." In potato and most roots starch is the predominating form of carbohydrates. In ripe fruits, on the other hand, some forms of sugar, as cane sugar, grape sugar (glucose), and fruit sugar (levulose), take its place as the principal ingredients. As far as food value is concerned it makes little difference in what form the sugars appear, there being practically no difference in the ease or completeness with which normal persons can digest and utilize them.

Protein and fats, which, along with the carbohydrates, constitute the three great groups of nutrients, are very much less abundant than carbohydrates. In fact, the protein of fresh fruits is found in such small quantities as to be practically negligible in the ordinary diet. Fats are fairly abundant in the avocado or alligator pear and in the ripe olive, but otherwise need hardly be considered. The ash of fruit represents the small amounts of various mineral matters which occur in almost all varieties. Such substances are necessary for the formation of the fluids and tissues of the body. Potassium salts, phosphoric acid, iron, and lime are perhaps the most important ones. The fruit acids (citric and malic are the most common ones) are generally present in fruits free or in combination with mineral substances in the form of salts. The characteristic flavor of fruits is due in considerable measure to the presence of such acids.

The value of fruit in the diet ordinarily depends not only on the nutrients and mineral matter supplied, but also on the fact that it has a pleasing flavor and furnishes a healthful variety, and upon the acids, which are believed to aid in digestion. Its appearance, aroma, and flavor certainly stimulates the appetite and very probably the secretion of digestive juices also. Variety in diet is especially important for persons whose appetite is poor, as it tends to make their meals more attractive and so helps them to take the needed amount of food. As sources of energy, dried fruits compare with cereals and starchy vegetables rather than with fresh fruits. On the other hand, they yield less protein than cereals and legumes and only negligible quantities of fat.

To measure the final value of food to the body, not only the amount of nutrients provided enters into account but also the ease and completeness with which they may be digested and utilized by the body. Much experimenting has shown that from the vegetable foods of the ordinary mixed diet in this country, 84 per cent of the protein, 90 per cent of the fat, and 97 per cent of the carbohydrates are available for the uses of the body. The digestibility of the protein and fats of fruits is about the same as that of the vegetable foods in general, but the value for carbohydrates is lower, being only 90 per cent. This difference is probably due to the fact that fruits contain large proportions of cellulose, such as the seeds and skins, that escape digestion. This does not necessarily make them unwholesome. On the contrary, a certain bulk of indigestible material tends to prevent sluggishness in the passage of food through the intestines, and except to persons of extremely delicate digestion this is often a decided advantage.

The healthfulness of fruit has been conclusively shown by practical experience and technical experiment. In tests by the California experiment station, healthy persons living on a diet made up very

largely of fruit, both fresh and dried, and nuts were found to keep well.

Many fruits have a mildly laxative effect, ascribed in part to the bulk which their cellulose gives to the material in the intestines and in part to the acids and salts they contain. This effect seems to be fully as great with dried fruits as with fresh. It is especially marked in the case of prunes and figs, which are frequently of benefit to persons inclined to constipation. Heat appears not to affect the laxative properties any more than drying, and, as far as this effect is concerned, it makes no difference whether the fruit is raw or cooked.

#### WAYS OF USING DRIED FRUIT.

Many of the dried fruits which have been spoken of are commonly used as they are bought, and most of them are even more commonly used in cookery. As a general thing, higher grades are selected when dried fruits are to be served plain than when they are intended for cookery, and it is here that washed figs, fancy prunes, the choicer dates, and high-class table raisins find their principal use. If there is any reason to suspect that such fruits are not clean they should be washed quickly and dried before serving. Such dried fruits are especially useful for dessert and similar purposes in winter, when fresh fruits are not abundant. In general, it may be said that dates and figs are more commonly used uncooked, while raisins are common both ways, and prunes usually cooked. Dates and figs are much used in making confectionery and not infrequently used in cake baking and in other similar ways. Stuffed dates, which are of rather recent introduction in the United States, at least as an article of commerce, have long been popular in the lands where the date palm grows. Dates are so rich in sugar that in a mixed diet in this country they should be used as sweetmeats or accessories rather than in large quantities, unless they are substituted for a part of the sugar of the usual diet, as is the case when they are cooked with breakfast cereals or added to them when served, a custom which has become quite common.

Such dried fruits as apples, apricots, peaches, etc., are seldom eaten without preparation. The first step in cooking them is to replace the water which was removed when they were dried, and this is ordinarily done by soaking them for several hours. Dried fruits thus treated will often regain their original shape, but not all their original color and flavor. When they have absorbed something like their natural water content they are ready to be cooked in almost any of the ways in which the fresh fruit can be used. The food value of a dish of cooked dried fruit is practically the same as that of fresh fruit prepared with a like amount of sugar

and juice. Evaporated or dried apples, properly soaked, can be used like the fresh fruit for making pies and such puddings as "Brown Betty," and in countless other ways. Peaches and apricots, usually halved before drying, when soaked and cooked with sugar are very much like the freshly preserved fruit in flavor. Like evaporated apples, they may also be used for making pies, puddings, etc. Prunes are commonly soaked and stewed for use as breakfast or dessert fruit, and also used for making numerous dishes. Sometimes lemon juice, orange peel, or cinnamon is added to stewed prunes for the sake of variety. The combinations which can be made with dried fruits in cakes, puddings, ices, etc., are almost endless.

Raisins, currants, and citron are very commonly used in cake-making. Before stirring raisins or currants into cake batter, cooks usually dust them over with flour, in the belief that this prevents their settling to the bottom of the pan. That there is warrant for this belief has been shown by experimental studies made in connection with the nutrition investigations of this office. However, the density of the dough and the rapidity with which the cake is cooked are also important matters. If the oven is fairly warm and the heat is greatest at the bottom of the cake tin, the batter will stiffen before the raisins have time to settle. Raisins or dates are sometimes mixed into the dough in bread making. In many families such bread is liked for general use and also makes very good sandwiches for the lunch basket, or for other purposes. In a similar way chopped dates are sometimes put into breakfast muffins. Dried apples cooked in sugar or molasses were important ingredients of old-fashioned fruit cakes, and are still sometimes used for such a purpose. Cakes of a somewhat different nature, which contain large quantities of dried apples and other dried fruits, are characteristic of some regions of Europe, where they have been made by the same recipes for perhaps 200 years or more. Desiccated coconut, dates, candied orange, and lemon peel are also of service either for adding to cakes and puddings or for mixing with the icings for cake. The crystallized fruits are so rich in sugar that they are chiefly used for sweetmeats or for garnishing other dishes, candied cherries being perhaps most often selected for garnishing because of their attractive color. Candied angelica stalks are usually chosen for garnishing when a green color is desired, while candied orange peel, pineapple, and apricot furnish a yellow garnish. Dried fruits and fresh fruits are often used together in making conserves, as, for example, a combination of raisins and pears flavored with ginger root.

#### ECONOMY OF USING DRIED FRUITS.

To determine which of two fruits is really the more economical, one should know not only the cost of each per pound but also the

amount of protein and energy a pound would supply, and should take into account the amount of material, fuel, and labor required to prepare the two foods for the table. Grapes commonly cost less per pound than raisins, but a given sum spent for fresh fruit will buy a smaller amount of nutritive material, since the proportion of water is much higher than in the raisins. On the other hand, one can think of circumstances under which low-priced fresh fruit, which may be eaten as purchased, would in the end be as economical as a somewhat cheaper dried fruit, since the latter would require sugar and fuel and time to make it ready for the table. Such considerations as the ease of obtaining a supply, convenience of use, the liking for a particular product, and many other things besides cost must also be taken into account in comparing dried with fresh fruits. Attention should also be directed to the question of refuse, or inedible material. If seeded and unseeded raisins cost the same price per pound, the former would be more economical as well as more convenient, since the purchaser would not have to pay for the seeds.

As a whole, dried fruits can be called reasonable in price as compared with other common articles of diet. This has been shown by numerous studies made in connection with the nutrition investigations of the Office of Experiment Stations. Some less general comparisons may also be made from the results of such studies. For instance, it appears that practically all the fruit products contain little protein, and as sources of this food constituent are so much more expensive than the cereals and dried legumes and most animal foods that there is practically no comparison between them. However, as sources of energy, derived almost entirely from their sugars and other carbohydrates, dried fruits are decidedly cheaper than meats, and compare favorably with dairy products, but are more expensive than cereals and starchy vegetables, such as dried beans and potatoes. When compared with one another, the differences in composition are relatively small, so that the selling price of different sorts of dried fruits is the main point when one is considering relative economy. This means that the housewife who wishes to economize can secure as much nutritive material from dried apples at a low price per pound as she can from a fancy grade of dried apricots at a much higher price per pound, though the flavor may not please her so well.

When every penny spent for food must bring the largest returns in actual nutritive value, questions of flavor and attractive appearance are of secondary importance, but when the income allows a range of choice, it is perfectly justifiable to consider them, and a family which can afford expensive meats and selected grapefruit can also purchase fine layer raisins for use as dessert, and fancy brands of other dried fruits. In the family where means are limited, the cheaper sorts must be chosen, but under any circumstances fresh

and dried fruits should not be thought of as a luxury, since they may be used as an integral part of the diet to supply needed nutritive material, as well as add to the attractiveness and palatability of the daily fare. If they are to be eaten raw, care should always be taken to select brands which are made and marketed in a cleanly way, and most persons would prefer to pay a few cents more per pound, if necessary, to be certain that the brands are of this character. Dried fruits in sealed cartons or packages are much less readily soiled in market than those sold from open boxes. Unfortunately, neither price nor appearance is necessarily an index to cleanliness, and it is often difficult for the ordinary buyer to know where and how dried fruit was prepared and marketed. Those who are familiar with the facts in the case believe that the use of evaporators and other mechanical devices results in a much cleaner product than the old-fashioned methods, and that American dried fruits are the equal of any in this respect, and much more cleanly than those which are imported from Mediterranean regions. In using dried fruits in cookery every attempt should be made to secure clean, wholesome goods, to remove any bits of stem or other material accidentally present, and to wash the fruits before using them if they are not already clean. The heat of cooking will sterilize them, to be sure, but most of us prefer material which we do not need to sterilize to render it safe and wholesome.

Whether used by themselves as substitutes for fresh or preserved fruits, or mixed into cakes, puddings, confectionery, and other dishes, dried fruits offer a wholesome, nutritious, and economical way of securing variety in the diet, and are especially useful where the supply of fresh fruits is limited, or where storage space for fresh fruits is lacking.

## POSSIBLE SOURCES OF POTASH IN THE UNITED STATES.

By FRANK K. CAMERON,  
*Bureau of Soils.*

### INTRODUCTION.

It is traditional in European countries for the several Governments to maintain a peculiarly active interest in the salt supplies, this state of affairs being especially well exemplified in the historical "salt monopolies" by which the Governments were assured of a certain revenue from a necessity for every citizen. About 1845 the German Government authorities, in an effort to increase the output of salt from the Magdeburg-Halberstadt region (better known as the Stassfurt region), drilled into the salt-bearing strata. Ultimately the main body of rock salt was penetrated, but in the upper layers or overburden there were found to be large quantities of "bitter" salts or a mixture of potash and magnesium salts which, designated as "abraunsalz," were regarded as worthless impedimenta. About 1870, mainly under the influence of the distinguished savant Liebig, the value of the bitter salts as a soil amendment or "fertilizer" was established, and from that time hence the potash salts have been the most valuable output of the mines. The use of potash salts became widespread throughout the world, wherever intensive agricultural methods and fertilizers were employed.

Practically, and with a few comparatively unimportant exceptions, the world's supply has always come from the German mines, and the Government, as a practical conservation measure, regulates and controls the mining and sale of the product. The material is marketed through a "Kali Syndikat" made up from all the mine ownerships and under the supervision of governmental officials, the quantity which may be produced and marketed being allotted amongst the mines, and prices fixed by the Syndikat, with the general restriction that no greater amount shall be exported than is sold in the German Empire.

It is obviously desirable that the United States should be independent of any other nation for its supply of a necessary product. Quite aside from the political arguments usually advanced in this connection, the Stassfurt deposits are not inexhaustible and are, moreover,



subject to various vicissitudes which might at any time spell disaster for this nation, which is so largely dependent upon agriculture for its welfare and stability. From time to time, and in spite of every care and precaution, a boring has become flooded, with the inevitable abandoning of the mine and permanent loss of the potash contents at least. In the past this has attracted considerably less general attention than its importance deserved, because the general market was not affected greatly and because often the particular management affected has sunk new shafts in the neighborhood and resumed operations. Recently one of the mines has been flooded, with the result that overnight, as it were, 1 per cent or more of the world's visible supply of potash disappeared.

Within the past few years certain American importers of potash salts, endeavoring to develop trade arrangements of greater advantage to themselves than had hitherto prevailed, brought on a controversy with the Kali Syndikat, which in turn led to diplomatic exchanges between the Governments of the United States and Germany and attracted considerable attention in the public prints. In consequence of the attention and interest thus aroused, Congress directed that special investigations be promptly instituted by the Bureau of Soils and by the United States Geological Survey to determine the possibility of obtaining, on a commercial scale, potash salts of American origin.

These investigations have been in progress at the present writing for about 18 months. They have stimulated private enterprises to a considerable extent, and the result of these several activities appears to be sufficient to show that the commercial production of potash salts from American sources and in quantities sufficient to meet the growing needs of the Nation is quite practicable. The investigations in this direction are by no means completed, are, in fact, yet in their infancy, and what the ultimate possibilities of American potash may be can not be predicted as yet. Before describing the more important American sources of potash, a brief résumé will be given of some possible minor sources.

#### MINOR SOURCES.

##### WOOD ASHES.

Of the minor possible sources of potash, the one which has attracted most attention is wood ashes. The quantity of sawdust produced in this country amounts to nearly 6,000,000 tons annually, which, if burned properly, might yield approximately 6,000 tons of potassium carbonate. But the sawdust is accumulated at so many widely distributed points, many of which are so poorly situated as regards transportation and other economic facilities that there seems

but small possibility of sawdust ever having any importance as a source of potash, except, possibly, in a very local way under exceptionally favorable conditions.

A relatively unimportant quantity of wood ashes is produced in this country. Some is imported from Canada. For the fiscal year ending June 30, 1910, there was imported a little more than 5,000 tons, valued at about \$66,000. Figures for the tonnage of the succeeding years are not available, but as the valuation of the imports of ashes, beech wood, and lye were \$50,973 (1911), and \$40,212 (1912), it is evident that wood ashes as a source of potash is not only comparatively unimportant in the United States, but such as it is, it is rapidly falling off. Wood ashes command, however, a comparatively high price. Thirteen brands on the Massachusetts market, averaging 3.77 per cent potash ( $K_2O$ ), sold for an average price of \$12.60 per ton.

WOOL WASHINGS.

Next to wood ashes may be considered wool washings, or "suint," which in some parts of Europe have been utilized as a source of potash. The foreign matter removed from wool by scouring varies widely, from 15 to 70 per cent, and is known commercially as "wool yolk." This material contains: (1) Sand, earth, etc; (2) wool grease, which is insoluble in water but which forms emulsions with soaps and alkaline solutions; and (3) "suint," or dried sweat, soluble in water and containing the potash salts. By treating the raw wool with warm water previous to scouring, the suint is dissolved, and in this way the potash salts of wool yolk may be recovered. Generally, however, all three classes of constituents are removed together in the scouring process and allowed to go to waste, since the recovery of potash and fatty acids can not be accomplished economically, except on a large scale.

Suint consists chiefly of the potassium salts of fatty acids which, when calcined, yield an ash having a composition approximately as follows:

	Per cent.
$K_2CO_3$ .....	73
$K_2SO_4$ .....	3
KCl.....	7
$Na_2SO_4$ .....	5
Insoluble ~.....	12

The quantity of potash which might be recovered from suint can not be accurately estimated. Wool in the grease, or raw wool, contains potassium which, expressed as potassium carbonate, approximates 5 per cent. The wool cut in the United States may be taken, in round numbers, as 160,000 tons, so that the maximum possible yield of potassium carbonate would be something less than 8,000 tons,

worth possibly \$500,000. Considering the wide distribution of the wool cut in America and the slight probability that the individual scourers could be induced to recover potash, or even suint, wool does not promise much as a possible source of potash. It is reported that some of the larger slaughterhouses and packing establishments are running washings from their sheep through peat, thus absorbing quite completely the potash and enriching the peat for subsequent use as a filler in mixed fertilizers.

#### POMACE AND VINASSE.

The pomace from wine presses, vinasses from sugar mills, and other wastes are possible, but not probable, sources of potash. Generally these wastes, if usable at all, could be more advantageously employed in some other manner, possibly for direct application to the soil. On the other hand, no very definite statements in this connection are justified, for these substances have not been thoroughly investigated.

#### ARTIFICIAL NITER.

The artificial production of niter or potassium nitrate is still practiced largely in various parts of the world, notably in India, where recent governmental investigation seems likely to bring about some technical improvements in the time-honored practices. The United States imports annually about 3,000 tons of potassium nitrate, worth approximately \$200,000, a very small percentage of which goes into fertilizers, it being utilized mainly in the manufacture of certain types of explosives and fireworks. The United States could, of course, if necessity arises, produce enormous quantities of potassium nitrate. But the economic and social conditions in this country are such that it is extremely improbable that any commercial production will ever be attempted.

#### SUNFLOWERS AND DESERT PLANTS.

In Russia sunflowers grown on waste lands are gathered and potash obtained by incinerating the stalks. It has been proposed to follow this idea by growing sunflowers on some of the desert areas of the United States, and several propositions have been advanced to gather indigenous plant growths on desert and waste lands and produce potash by burning them. None of these proposals have yet assumed sufficiently definite shape to warrant consideration as a commercial proposition. While some attention has been given the matter by the Bureau of Soils, the data have not justified any serious expectations of commercial possibilities in this direction.

## CARBONATE PONDS OF NEBRASKA AND VICINITY.

In certain of the Western States, notably in western Nebraska, are a number of small lakes or ponds whose waters are quite saline, and contain noticeable proportions of potassium carbonate. The explanation of the origin of the potassium carbonate which has received most credence is that the vegetation of the surrounding country has been repeatedly burned over and that the potassium carbonate from the resulting "wood ashes" has been leached out by rain and carried into the lakes, which have no outlet or relatively inefficient outlets. The climate being semiarid, the evaporation is high, and consequently a considerable segregation and concentration of potassium carbonate has occurred in some of the lakes. None of these lakes, nor all of them in the aggregate, probably contain enough potash to give them any great general economic importance, though some of the individual localities might justify working. Indeed, preparations have been made to work one or more of them. There is no present expectation, however, that the potassium carbonate to be recovered is to go into the fertilizer market.

## ROCK SALT AND BRINES.

The United States contains a number of rock-salt deposits and many salt wells. An examination of a large number of the brines, salt, and bittern from these wells and deposits has been made, as well as a study of the theoretical and practical principles involved in the separation of potash salts from the other products yielded. Potash is invariably a constituent, but never in quantities that would justify any attempt to obtain it thus commercially, excepting possibly in the case of the potassium carbonate lakes of Nebraska already discussed, and at Searles Lake, in California, which will be discussed presently in connection with the desert basins. Certain of the American salt deposits, notably those in New York, Michigan, Ohio, Kansas, and possibly in Louisiana, are enough like the deposit at Stassfurt in origin and general geologic features to suggest the probability of segregated deposits of potash. From theoretical considerations as well as practical experience at Stassfurt, it would be expected that potash layers, if existing at all, would be found above the main salt bed. No such layers have been observed in the case of any American deposit, and they have been sufficiently explored now to make quite remote the probability of American sources of potash from such deposits.

## MAJOR SOURCES.

## ALUNITE.

Turning attention now to the more important possible sources of American potash, alunite may be conveniently considered first. This mineral is a basic potassium alumino sulphate, is quite widely distributed in the United States, and is found in notable quantities at several points in Colorado, California, Arizona, Nevada, and Utah. Alunite has long been used in Spain and Italy as a source of alum, obtained by roasting the mineral, lixiviating the roasted mass, and evaporating the solution. Roman alum, produced thus from the mines at Tolfa, has long been known in the trade. Investigation has been made by the Bureau of Soils of the temperature and other conditions best suited to the production of alum or potassium sulphate from alunite and the possibilities of producing potash commercially from the alunite from various localities, of which only one has offered as yet any great promise. Near Marysville, Utah, occurs a large deposit of massive alunite, known for a number of years, but recently investigated by agents of the United States Geological Survey, who state, as a conservative estimate, that the Marysville deposit will yield 300,000 tons of alunite or 30,000 tons of potash for each 100 foot depth. How deep the deposit is can not yet be stated, but it occurs at elevations from 9,000 to 11,000 feet, and there is apparently good evidence that the main vein is a deep-seated one. Most if not all of the workable area is now in the hands of private parties who have substantial resources, and there seems to be good reason to think that potash from alunite may soon be a commercial product on the American market.

## FELDSPAR AND POTASH SILICATES.

There are within the United States many and large deposits of rocks and minerals containing potassium. The potash feldspars, orthoclase, and microcline are abundant, frequently massive, and widely distributed through nearly all sections. Another potash silicate, leucite, found in lavas, is important only in the region of the Leucite Hills, Wyoming, but occurs there in very important quantities. The percentage of potassium in these potash-bearing silicates varies considerably, not only with the mineral species, but with each mineral. Probably it would average between 8 and 10 per cent, sometimes running as high as 16 per cent, and it has long been the dream of inventor and chemist to develop a commercially practicable method of extracting the potash from them. To this end a long list of patents has been granted in the United States and other countries. Of the methods so far proposed only a few merit consideration here. A general investigation of the various methods for which

patents have been issued has been made in the laboratories of the Bureau of Soils. It was found, as has been noted by others, that there is small probability that any "potash from feldspar" proposition which depends on the production of potash salts alone can have a commercial future, but that commercially available by-products must also be produced.

The temperatures and other conditions necessary for extracting potash from feldspar, by fusion with lime or other reagents, was investigated, and it was shown that by substituting ground feldspar for "clay" or "shale" a satisfactory clinker for cement purposes could be produced and the potash volatilized quantitatively. A somewhat similar process has been devised by Eakel and Spenser where greensand or glauconite was employed instead of feldspar. That the flue dust from cement kilns and other similar industrial operations frequently contains potash or potassium salts has been known for some time past. In the majority of such plants it has been held that the loss of material through the stack is too small to justify the installation of a precipitating or trapping system. One large cement plant in southern California, which has recently been equipped with a highly efficient precipitating device in their flues, and which has been employing a granite containing appreciable proportions of potash feldspars, is now experimenting on the possibilities of recovering potash from the flue dust, with rather promising results so far; and experiments with a small experimental plant are now under way in the Bureau of Soils to test the results of employing a high potash-carrying feldspar.

There is in course of erection at Curtis Bay, near Baltimore, under the auspices of a well-known firm of chemical manufacturers, a small plant for the production of potash salts from feldspar, according to the Firmin-Thompson process. Essentially this consists in heating a mixture of ground spar and niter cake or acid sodium sulphate together with sodium chloride in a rotary or Wedge or other suitable furnace. Hydrochloric acid is given off and trapped in the usual manner. The solid residue is leached with water, and the percolate evaporated, potassium chloride being separated by fractional crystallization. Other products of the operation are a very pure sodium sulphate and a pulverulent soda-lime-alumina silicate, with a probable value for certain types of glazing. No potash from this process is yet on the market, but the promoters expect shortly to produce about 40 tons a day.

In the Cushman-Coggeshall method the ground spar is mixed with calcium chloride, or lime and sodium chloride. By an ingenious "clumping" device the mix is brought into the form of pellets which are then passed through a furnace with definite heat relations. The

roasted pellets are granular and in a form to be readily pulverized if desired. The product contains about 4.5 per cent of water-soluble potash, although the inventors claim a higher percentage is readily obtainable. It also contains a notable proportion of calcium chloride. It is suggested that this product is to be regarded as a fair substitute for wood ashes and should bring a commensurate price. If, however, the product must be marketed as a low-grade potassium chloride, it can be produced only at a loss. It is understood that this process has been exploited experimentally in the interests of one of the large manufacturers of fertilizers. So far the product has not been marketed.

Another of the large fertilizer manufacturers has been developing a process, the details of which are as yet not public. Essentially the process consists of heating a mixture of ground spar and coal in a stream of nitrogen or ordinary air at certain regulated temperatures and pressures. It is said that a volatile product or mixture of products is obtained which, when treated with steam and then leached yields potash, potassium carbonate, ammonia, carbon monoxide, and iron-free alumina. All of these products are readily salable, and there is left only a small mass of ferruginous material and lime silicate. A factory is now in course of construction, and if the practical results even approximate the laboratory results reported the "potash from feldspar" problem will have been solved.

While the extraction of potash from silicate carriers has been suggested in many other ways, none of them has acquired sufficient practical promise to justify a mention here.

#### DESERT BASINS.

Throughout the greater part of the far western States are numerous topographic units known as desert basins. In past geologic times folding and subsequent faulting produced many troughs and depressions, some of which were of stupendous depth. Into these the waters descending from the surrounding heights carried silt and dissolved mineral matter derived from the rims and carrying, of course, more or less potassium. Generally, the resulting topography was such that outlets were either nonexistent, temporary, or, at all events, insufficient, so that lakes were formed, some of vast extent, as the ancient Lahontan, or Bonneville. With the advent of arid periods these lakes evaporated, and their mineral contents concentrated, probably to the points where deposition of previously dissolved content took place. Probably periods of desiccation and of humidity alternated. But throughout all these periods all the troughs were gradually filling up with erosional detrita, until they have reached their present levels.

It is possible that during a period of desiccation salt was deposited from the then existing lakes, and that the deposition proceeded sufficiently far for the potash salts to be laid down in segregated layers. Laboratory investigations, confirmed by observations at Stassfurt and elsewhere, show that the potash salts, if deposited at all, should be expected in the upper layers. If, now, silt deposits covered these salt layers so as to protect them more or less efficiently from subsequent floodings, a "potash mine" may exist potentially in a desert basin if not too far below the surface to make its working commercially feasible.

It is possible, on the other hand, that desiccation never proceeded to the point where potash salts crystallized from the concentrating waters, or that it was not protected by a silt covering, and though indubitably potash, and perhaps much of it gone into the basin, it is disseminated through the silt fill. In such case no potash mine can be expected.

It is impossible from any known criteria to determine or even intelligently guess a priori whether a segregated layer of potash lies or probably lies below the surface of a desert basin. The only way to find out is to bore. But before doing so it would be wise to consider the drainage area to the basin, the character of the rim rocks, and any other features which might be expected to affect the amount of potash which has been carried into the basin. About 200 basins have been examined in the past 18 months by the Bureau of Soils, and it has been possible to reduce the number in which there is any probability of potash being found to a very limited number, about 20, in which the chance may be regarded as good, and possibly as many more in which it may be considered doubtful. In any event, however, it is only a chance that a segregated layer of potash salts will be found. A boring has been put down by the Geological Survey, near Fallon, Nev., and private enterprise is putting down borings in the Railroad Valley and Dixie Valley, one of which has gone nearly 1,200 feet without "finding potash." An encouraging sign is the fact that the water from these borings has been quite fresh, and since there can be little doubt that much potash has been carried into the basins, the fresh water indicates that it is not disseminated through the fill, but probably segregated. But nothing definite has been indicated regarding the depth at which the segregations may be expected. A potash mine in a desert basin is yet a legitimate hope, but without definite promise of realization.

Sometimes the floor of a desert basin may carry a considerable salt deposit, but more often not. The surrounding mountains are bordered by "aprons" of descending slope merging finally into a flat plain in which there is at the point of greatest depression a "playa"



or possibly a small lake. Usually the playa is a mud flat, and the place of concentration of the present drainage. One such playa, that of Searles Valley, is known to be of importance as a possible source of potash. The bottom of the Searles depression or Searles Lake is a body of white crystalline salt approximately 12 square miles in area, of varying depth, reaching probably 75 feet. Saline muds and sands, more or less well cemented, underlie the surface salt, the whole being saturated by a brine. The salts are mainly the chloride, carbonate and sulphate of sodium, lesser amounts of borax, and some potassium chloride, the potassium salts being mainly in the brine. This salt body has been until recently in the control of private interests. It is reported that they have satisfactorily worked out methods for separating the commercially desirable constituents, carbonate of soda, borax, and potassium chloride, and that the materials are in preparation for the installation of a large plant to produce and market these products. What is regarded as a very conservative estimate is that this deposit may ultimately yield 4,000,000 tons of potassium chlorid. Probably it will yield more. It has now been withdrawn from entry, at least temporarily, and its exploitation thereby delayed.

If plans now being contemplated for the diversion of the flow from the watershed of Owens Lake are finally consummated, that lake will gradually dry up, and in the final residue a considerable amount of potassium chlorid will be present. The chief value of the products of desiccation, however, will probably be in the borates. Agents of the United States Geological Survey have reported that the muds of Columbus Marsh contain notable quantities of potash salts and suggest that these may be economically recovered from the mother liquors from borings. This marsh is a broad mud plain lying on the line between Esmeralda and Mineral Counties, Nev., near the station of the Coaldale, Tonapah & Goldfield Railroad. The mud is of unknown depth. Wells to a depth of 50 feet have been sunk. On the average, the mud contains about 6 per cent of soluble salts and nearly 2 per cent of potassium chlorid, and it is thought that the mother liquor from the mud, if it can be economically separated from the solid material, will have a sufficiently high potash content to justify working it. Under the recent law, amended August 24, 1912, the President withdrew from entry January 16, 1913, all the lands of Columbus Marsh which are likely to yield workable quantities of potash salts, pending further investigation of their probable economic importance.

The salt mixture in the ocean is chemically neutral, and hence the salt deposits of Stassfurt resulting from the desiccation of sea water are neutral. It does not follow, however, that the solution resulting from the solvent action of meteoric waters on the rock masses of any particular area will be neutral. They may be, and

probably, in general, would be alkaline, basic constituents predominating over acid if volatile carbonic acid be ignored. Thus the salt mixtures and brine at Searles are strongly alkaline chemically, as is the case with quite a number of lakes and ponds in arid areas. If much lime is brought into the water, it is largely precipitated and precipitates as carbonate, sulphate, borate, or slightly soluble solids, and the resulting aqueous salt mixture approaches a neutral condition. The water of the Great Salt Lake, the residue of the former great Lake Bonneville, is now practically neutral, although if a portion be sufficiently diluted with pure water, it will be found alkaline, as shown by the addition of a few drops of the usual alcoholic solution of phenolphthalein.

#### GIANT KELPS.

At the present time probably the most promising American source of potash is the giant kelps of the Pacific coast. There is a fairly large number of different kelps and rock weeds growing on the coast, from all of which it is possible to extract notable quantities of potash and iodine, and some of these algæ have been shown to have other commercial possibilities. Of the several varieties and species two are of importance as possible commercial sources of potash, *Nereocystis luetkeana* and *Macrocystis pyrifera*. These algæ grow in large beds or groves of practically pure stands. In northern waters, from about Point Sur up to the Arctic, *Nereocystis* is the important kelp. *Macrocystis* is found in fairly good-sized stands in Puget Sound and all along the coast southward, but from Point Sur southward it is the predominant kelp. In fact, the large groves of *Macrocystis* along the coast of southern California and Mexico far surpass in importance any other now known. These groves have been located and mapped from Puget Sound south. They will probably aggregate in area nearly 100 square miles on the Mexican coast and about 120 square miles on the American coast, excluding Alaska.

*Nereocystis* is apparently an annual. At least it dies out in the fall and grows anew in the spring. Consequently, in order not to interfere with the fruiting or development of mature spores, this plant should be "protected" and its cutting prohibited until after July 15. This is a point possibly of great importance for the building up of a kelp industry dependent on this variety. Investigation is now in progress to determine the possibility of building up such an industry in connection with the fish-scrap industry, already existing, to the material advantage of both. There are apparently great economies possible in equipment, etc., but there are also some undetermined factors, among which the labor and season are prominent, and which have not been satisfactorily investigated as yet.

*Macrocystis* is perennial, or at least has a life history extending over a year. It has been reported that groves cut to a depth of a fathom or more have regrown to their former luxuriance within 40 to 60 days. Therefore several cuttings a year are practicable, apparently, especially as the main regions for spore production are on portions of the plant at much greater depths than would ever be cut. Recent observations, however, on the mechanism of regrowth after cutting make it desirable to withhold for the present any positive expressions of opinion as to how many cuts or harvests a year will be possible.

The kelp stands of Alaska have not as yet been mapped nor thoroughly investigated. Preliminary reports indicate that some very heavy stands exist in individual groves, and these reports, confirmed by the charts of the Coast and Geodetic Survey, indicate that in the aggregate the kelp groves of Alaska may equal if not surpass in extent and importance those already mapped.

There are at present on the Pacific coast four commercial organizations for marketing kelp, and a number of others have been reported as in the formation stage or about to begin operations. These companies claim to have met successfully the presumably difficult problem of cutting and harvesting the kelp. One of the more successful ones which has actually been marketing kelp has a scythe device mounted on a barge, and by an endless chain mechanism cuts and loads the kelp on barges alongside in ordinary weather. It is claimed that they cut, drain, and deliver their product on shore at a cost of less than 60 cents per ton, wet. This would be equivalent to something less than \$3 a dry ton of kelp, and with experience and consequent improvements it is probably quite practicable to reduce the cost of harvesting the kelp to about \$2 per dry ton.

The kelp in drying loses about four-fifths, or a little more, of its weight of water. This it does quite readily, and the fear sometimes expressed that a large heat cost is involved is quite unfounded, as generally simple air-drying is quite sufficient to remove the greater part of the water. A more serious difficulty is that, in drying, much of the salts, largely potassium chlorid, effloresce on the surface, are easily shaken off, and are likely to be lost.

One of the companies operating on the Pacific coast is chopping the kelp into small lengths and marketing it wet, to be used as a top dressing and fertilizer. Undoubtedly, with many crops and on most soil this should prove a good practice as far as crop increases are concerned. It is not certain, however, that the practice, inherently involving freight charges on a large percentage of water, will prove commercially desirable, and further experience must be accumulated before a satisfactory judgment can be formulated.

The dried kelp contains from 20 to 35 per cent, or occasionally even more, of potassium chlorid, and is more desirable than manure salts or ordinary market grades of potash salts, not only because of its high content of potash, but because of the readily decomposable organic matter, a content of about 2.5 per cent nitrogen, and appreciable amounts of readily soluble phosphates, all of which give it an important fertilizer value.

The recovery of high-grade potassium chloride from the kelp is no more difficult than from the Stassfurt salts. The recovery of iodine and organic products, leaving a residual rich in potash, is quite feasible, but has not yet been attempted in this country, except on a laboratory scale, although now practiced in Japan.

The amount of potash salts obtainable annually from kelp can not be stated at all satisfactorily at present. It is certainly large, and if careful supervision of the beds and harvesting be provided, it seems safe to assume that the yield of potassium chloride could be made to surpass the entire present consumption of potash salts in this country. Counting in Alaska, the annual yield might possibly be several times this amount. But there are a number of factors not yet sufficiently well known or understood to make possible any more than tentative estimates.

These kelp groves are a great national asset. More particularly they are an asset of the States along whose shores they occur. Being generally within the "three-mile limit" they fall under the control and supervision of the individual States, whose obvious duty is to protect them and conserve them that they may continue indefinitely. A kelp "proposition," unlike a mine, requires no amortization feature. Restrictive legislation should, however, be enacted very cautiously, as it is of the greatest importance at this time that kelp industries should be encouraged, and there is yet wanting a sufficiently definite basis of knowledge on which to found regulations conducive alike to the utilization of the kelp groves and their maintenance and perpetuation.

A characteristic of the "potash from kelp" propaganda is that large capital is quite unnecessary. A very modest outlay for harvester, dryer, and working capital is required.

That a large growth of kelp exists, capable of producing an enormous tonnage of potash salts, has been demonstrated. It has also been demonstrated that kelp can be harvested and prepared for market at a cost commercially practicable. A business in kelp actually exists, though small. It remains to be proven that a stable business, capable of meeting the national necessities, can be established, and to this end should be lent all possible assistance from Federal and State governmental activities and private enterprise.

## SUMMARY.

To sum up, it may be said that the United States has at hand known possible sources of potash sufficient to supply its present and prospective needs. It has possibly, but not yet proved, sources sufficient to supply many times its own needs. Some of these have apparently so much promise, commercially, as to justify the expectation that potash salts of American origin may be a factor in the market in the near future.

Finally, however, it seems wise to repeat the warning previously given (62d Cong., 2d sess., S. Doc. No. 190, p. 48) that "while the conclusion is justified that kelp groves, alunite, or other sources of potash can be exploited commercially and even, perhaps, at large profits, it is by no means to be assumed that any particular proposition which may be promoted is safe and desirable. Prospective investors are again urgently warned to hesitate until they have obtained such information as may be given by public officials and the advice of a reliable and disinterested chemist or engineer who has carefully inspected the particular proposition in view.

## THE COMMERCIAL WEATHER MAP OF THE UNITED STATES WEATHER BUREAU.

By HENRY L. HEISKELL,

*Chief of Division, United States Weather Bureau.*

The first weather map was published in a newspaper of the United States, May 12, 1876, at the International Exposition at Philadelphia. The New York Herald, printed on the grounds, published a small copy of the daily map. The central office at Washington received reports from a few stations for use in making the map. The map was charted at the Washington office of the Signal Service and transmitted by telegraph each day to Philadelphia by the process of autographic telegraphy, which was not effective at great distances, as it required a special instrument. This was an exhibition map for show purposes at the exposition.

The next map to be published appeared in the New York Graphic, with but few interruptions, from 1879 to 1882, and was published at the expense of the Signal Service, being a facsimile of the morning weather map, traced at Washington, and telegraphed in special cipher to the observer in charge of the New York station. Later the cipher reports were telegraphed direct to New York and were used in making a daily map.

This method of making the map at station from telegraphic cipher reports was thereafter put in general use. In 1881 the Cincinnati Commercial published a daily weather map, including Sundays and holidays, which was continued until November, 1892, the longest period in which the weather map was published by any newspaper up to 1910. Twenty-six other papers published the map at various periods previous to 1910.

The maps were occasionally reproduced by zinc etching by the photographic process from a pen copy, but chalkplates, 3 by 4 inches in size, having inscribed on their surfaces an outline of the United States and circles locating the stations, were generally used. The data and lines were engraved on the plate by the station officials and the newspaper stereotypers made the cast.

The papers issued the map for irregular periods and finally discontinued the publication, as the map occupied too valuable space; the mass of readers did not understand and appreciate the map, and

the expense of publication was too great. The expense consisted not only in the loss of space occupied by the map, but the papers were required to furnish the chalkplates and do the casting.

In 1910 a determined effort was made to improve these conditions and to have the commercial map published in the local papers at the larger stations by furnishing the papers with a more creditable chalkplate map, the only expense being the space required. When a zinc etching was used the paper was furnished a clear, legible copy for photographic reproduction. If a chalkplate map was desired the paper was furnished the chalkplate and also a cast when requested.

## WEATHER CONDITIONS AT 8 A. M.

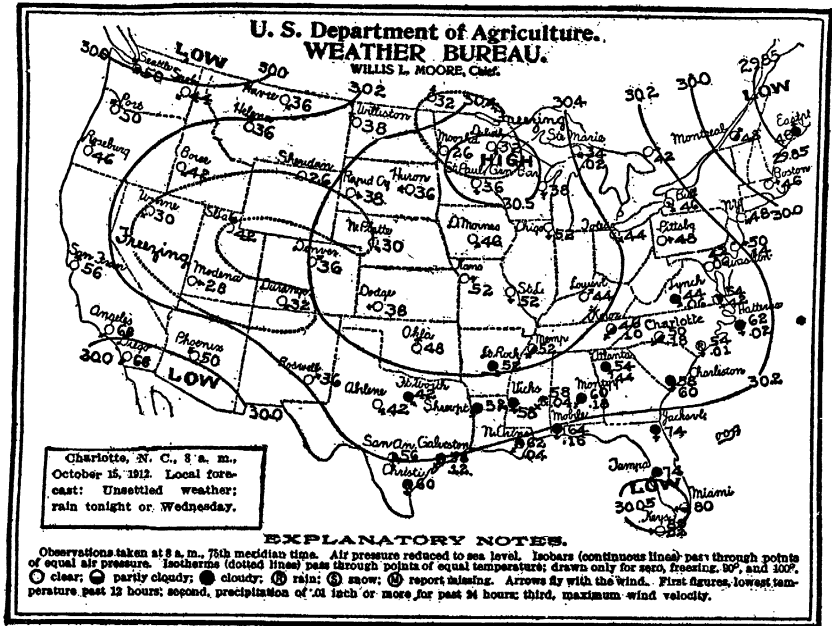

FIG. 19.—A typical commercial weather map, published by many newspapers throughout the United States.

By this method the map is published regularly and made available, without great expense to the bureau, to hundreds of thousands of people where previously it had reached but a few thousand. (Fig. 19.)

By using the newspapers two issues of the map each day—morning and evening—were given to the public, where previously only the morning map was available. By means of a masterplate containing an outline map of the United States and the Weather Bureau stations, and using a pantograph for transferring these lines and stations to the chalkplate, the process has now become almost perfect.

Many papers have commended the map as an addition of great value to the news columns of the press. The *Minneapolis Journal* was the first paper to publish the map at this time, beginning on March 1, 1910. Other papers took it up in rapid succession. Before the end of the first month papers at Boston, New York, Binghamton, and Atlanta had begun publication. Within the first four months from date of first issue its publication had been extended to 65 daily papers in 45 cities. By the end of the year 1910 the publication had extended to over 100 papers, and by July 1, 1911, the map was published at 74 places in 132 papers, with a total daily circulation of 2,898,000. At the same time the issue of the daily station map was but 15,000, distributed between 58 stations. In 1912 the publication grew in popularity and numbers. On July 1, 1912, the map was published at 91 stations in 147 papers, with a total daily circulation of 3,036,000.

The advantages of this large circulation to the public are manifest. The average reader sees the map each day in his paper, examines it, and soon becomes interested in its study. He learns the general principles of forecasting, begins to make his own predictions, and learning from experience that meteorology is not yet an exact science, and that forecasts sometimes fail, becomes more reasonable in his criticisms of the official forecast.





## APPENDIX.

### ORGANIZATION OF THE UNITED STATES DEPARTMENT OF AGRICULTURE.

- Secretary of Agriculture*, D. F. HOUSTON.  
*Assistant Secretary of Agriculture*, BEVERLY T. GALLOWAY.  
*Chief Clerk*, C. C. CLARK.  
*Solicitor*, FRANCIS G. CAFFEY.  
*Appointment Clerk*, R. W. ROBERTS.  
Supply Division, CYRUS B. LOWER, *Chief*.  
Weather Bureau, H. E. WILLIAMS, *Acting Chief*.  
Bureau of Animal Industry, ALONZO D. MELVIN, *Chief*.  
Bureau of Plant Industry, WM. A. TAYLOR, *Plant Physiologist and Pathologist and Chief*.  
Forest Service, HENRY S. GRAVES, *Forester and Chief*.  
Bureau of Chemistry, CARL L. ALSBERG, *Chemist and Chief*.  
Bureau of Soils, MILTON WHITNEY, *Soil Physicist and Chief*.  
Bureau of Entomology, L. O. HOWARD, *Entomologist and Chief*.  
Bureau of Biological Survey, H. W. HENSHAW, *Biologist and Chief*.  
Division of Accounts and Disbursements, A. ZAPPONE, *Chief and Disbursing Clerk*.  
Division of Publications, JOS. A. ARNOLD, *Editor and Chief*.  
Bureau of Statistics, VICTOR H. OLMSTED, *Statistician and Chief*.  
Library, CLARIBEL R. BARNETT, *Librarian*.  
Office of Experiment Stations, A. C. TRUE, *Director*.  
Office of Public Roads, LOGAN W. PAGE, *Director*.

### SECRETARIES AND COMMISSIONERS OF AGRICULTURE.

- Reuben F. Kolb, commissioner of agriculture, Montgomery, Ala.  
Guy B. Tucker, commissioner of agriculture, Little Rock, Ark.  
J. A. Filcher, secretary State board of agriculture, Sacramento, Cal.  
L. M. Taylor, secretary State board of agriculture, Fort Collins, Colo.  
L. H. Healey, secretary State board of agriculture, Hartford, Conn.  
Wesley Webb, secretary State board of agriculture, Dover, Del.  
B. E. McLin, commissioner of agriculture, Tallahassee, Fla.  
J. J. Conner, commissioner of agriculture, Atlanta, Ga.  
Joseph P. Fallon, commissioner of immigration, labor, and statistics, Boise, Idaho.  
J. K. Dickirson, secretary State board of agriculture, Springfield, Ill.  
Charles Downing, secretary State board of agriculture, Indianapolis, Ind.  
A. R. Corey, secretary State board of agriculture, Des Moines, Iowa.  
F. D. Coburn, secretary State board of agriculture, Topeka, Kans.  
J. W. Newman, commissioner of agriculture, Frankfort, Ky.  
E. O. Bruner, commissioner of agriculture, Baton Rouge, La.  
J. P. Buckley, commissioner of agriculture, Augusta, Me.  
A. F. Trappe, secretary State bureau of immigration, Baltimore, Md.  
J. Lewis Ellsworth, secretary State board of agriculture, Boston, Mass.  
Addison M. Brown, secretary State board of agriculture, East Lansing, Mich.  
J. M. Simpson, secretary State agricultural society, St. Paul, Minn.  
H. E. Blakeslee, commissioner of agriculture, Jackson, Miss.  
T. C. Wilson, secretary State board of agriculture, Columbia, Mo.  
John J. Hall, commissioner of agriculture, Helena, Mont.

- W. R. Mellor, secretary State board of agriculture, Lincoln, Nebr.  
 Louis Bevier, secretary State board of agriculture, Carson City, Nev.  
 N. J. Bachelder, secretary State board of agriculture, Concord, N. H.  
 Franklin Dye, secretary State board of agriculture, Trenton, N. J.  
 Nathan Jaffa, secretary of state, Santa Fe, N. Mex.  
 Calvin J. Huson, commissioner of agriculture, Albany, N. Y.  
 W. A. Graham, commissioner of agriculture, Raleigh, N. C.  
 W. C. Gilbrath, commissioner of agriculture, Bismarck, N. Dak.  
 A. P. Sandles, secretary State board of agriculture, Columbus, Ohio.  
 G. T. Bryan, president, Benj. F. Hennessey, secretary, board of agriculture, Oklahoma City, Okla.  
 Frank Meredith, secretary State board of agriculture, Salem, Oreg.  
 N. B. Critchfield, secretary of agriculture, Harrisburg, Pa.  
 John J. Dunn, secretary State board of agriculture, Providence, R. I.  
 E. J. Watson, commissioner department of agriculture, commerce, and industries, Columbia, S. C.  
 C. N. McIlvaine, secretary State board of agriculture, Huron, S. Dak.  
 T. F. Pock, commissioner of agriculture, Nashville, Tenn.  
 Ed. R. Kone, commissioner of agriculture, Austin, Tex.  
 O. L. Martin, commissioner of agriculture, Plainfield, Vt.  
 G. W. Koiner, commissioner of agriculture, Richmond, Va.  
 I. M. Howell, secretary of State, Olympia, Wash.  
 John M. Millan, secretary State board of agriculture, Capitol Building, Charleston, W. Va.  
 J. C. Simpson, secretary State board of agriculture, Madison, Wis.  
 A. J. Parshall, State engineer, Cheyenne, Wyo.

#### AGRICULTURAL COLLEGES IN THE UNITED STATES.<sup>1</sup>

College instruction in agriculture is given in the colleges and universities receiving the benefits of the acts of Congress of July 2, 1862, August 30, 1890, and March 4, 1907, which are now in operation in all the States and Territories except Alaska. The total number of these institutions is 67, of which 66 maintain courses of instruction in agriculture. In 23 States the agricultural colleges are departments of the State universities. In 16 States and Territories separate institutions having courses in agriculture are maintained for the colored race. All of the agricultural colleges for white persons and several of those for negroes offer four-year courses in agriculture and its related sciences leading to bachelors' degrees, and many provide for graduate study. About 60 of these institutions also provide special, short, or correspondence courses in the different branches of agriculture, including agronomy, horticulture, animal husbandry, poultry raising, cheese making, dairying, sugar making, rural engineering, farm mechanics, and other technical subjects. The officers of the agricultural colleges engage quite largely in conducting farmers' institutes and various other forms of college extension. The agricultural experiment stations with very few exceptions are departments of the agricultural colleges. The total number of persons engaged in the work of education and research in the land-grant colleges and the experiment stations in 1912 was 7,666; the number of students (white) in interior courses in the colleges of agriculture and mechanic arts, 53,764; the total number of students in the whole institutions, including students in correspondence courses and extension schools, 210,269; the number of students (white) in the four-year college courses in agriculture, 9,546; in short and special courses (white), 15,594; the total number of students in the institutions for negroes, 8,495, of whom 2,173 were enrolled in agricultural courses. With a few exceptions each of these colleges offers free tuition to residents of the State in which it is located. In the excepted cases scholarships are open to promising and energetic students; and, in all, opportunities are found for some to earn part of their expenses by their own labor. The expenses are from \$125 to \$300 for the school year.

<sup>1</sup>Including only institutions established under the land-grant act of July 2, 1862.

*Agricultural colleges in the United States.*

State or Territory.	Name of institution.	Location.	President.
Alabama.....	Alabama Polytechnic Institute.... Agricultural School of the Tuskegee Normal and Industrial Institute. Agricultural and Mechanical College for Negroes.	Auburn..... Tuskegee Institute.... Normal.....	C. C. Thach. B. T. Washington. W. S. Buchanan.
Arizona.....	University of Arizona.....	Tucson.....	A. H. Wilde.
Arkansas.....	College of Agriculture of the University of Arkansas. Branch Normal College.....	Fayetteville..... Pine Bluff.....	C. F. Adams. <sup>1</sup> F. T. Venegar.
California.....	College of Agriculture of the University of California.	Berkeley.....	T. F. Hunt. <sup>1</sup>
Colorado.....	The State Agricultural College of Colorado.	Fort Collins.....	C. A. Lory.
Connecticut.....	Connecticut Agricultural College....	Storrs.....	C. L. Beach.
Delaware.....	Delaware College.....	Newark.....	G. A. Harter.
Florida.....	State College for Colored Students. College of Agriculture of the University of Florida. Florida Agricultural and Mechanical College for Negroes.	Dover..... Gainesville..... Tallahassee.....	W. C. Jason. J. J. Vernon. <sup>1</sup> N. B. Young.
Georgia.....	Georgia State College of Agriculture. Georgia State Industrial College....	Athens..... Savannah.....	A. M. Soule. R. R. Wright.
Hawaii.....	College of Hawaii.....	Honolulu.....	J. W. Gilmore.
Idaho.....	College of Agriculture of the University of Idaho.	Moscov.....	W. L. Carlyle. <sup>1</sup>
Illinois.....	College of Agriculture of the University of Illinois.	Urbana.....	E. Davenport. <sup>1</sup>
Indiana.....	School of Agriculture of Purdue University.	Lafayette.....	J. H. Skinner. <sup>1</sup>
Iowa.....	Iowa State College of Agriculture and Mechanic Arts.	Ames.....	R. A. Pearson.
Kansas.....	Kansas State Agricultural College..	Manhattan.....	H. J. Waters.
Kentucky.....	The College of Agriculture of the State University. The Kentucky Normal and Industrial Institute for Colored Persons.	Lexington..... Frankfort.....	J. H. Kastle. <sup>1</sup> G. P. Russell.
Louisiana.....	Louisiana State University and Agricultural and Mechanical College. Southern University and Agricultural and Mechanical College.	Baton Rouge..... New Orleans.....	T. D. Boyd. H. A. Hill.
Maine.....	College of Agriculture of the University of Maine.	Orono.....	R. J. Aley.
Maryland.....	Maryland Agricultural College.... Princess Anne Academy for Colored Persons, Eastern Branch of the Maryland Agricultural College.	College Park..... Princess Anne.....	T. H. Spence. <sup>2</sup> T. H. Kiah.
Massachusetts.....	Massachusetts Agricultural College. Massachusetts Institute of Technology. <sup>3</sup>	Amherst..... Boston.....	K. L. Butterfield. R. C. Maclaurin.
Michigan.....	Michigan Agricultural College.....	East Lansing.....	J. L. Snyder.
Minnesota.....	College of Agriculture of the University of Minnesota.	University Farm, St. Paul. Agricultural College....	A. F. Woods. <sup>1</sup> G. R. Hightower.
Mississippi.....	Mississippi Agricultural and Mechanical College. Alcorn Agricultural and Mechanical College.	Alcorn.....	J. A. Martin.
Missouri.....	College of Agriculture of the University of Missouri. School of Mines and Metallurgy of the University of Missouri. <sup>3</sup> Lincoln Institute.....	Columbia..... Rolla..... Jefferson City.....	F. B. Mumford. <sup>1</sup> L. E. Young. <sup>4</sup> B. F. Allen.
Montana.....	Montana State College of Agriculture and Mechanic Arts.	Bozeman.....	Jas. M. Hamilton.
Nebraska.....	College of Agriculture of the University of Nebraska.	Lincoln.....	E. A. Burnett. <sup>1</sup>
Nevada.....	College of Agriculture of the University of Nevada.	Reno.....	J. E. Stubbs.
New Hampshire....	New Hampshire College of Agriculture and the Mechanic Arts.	Durham.....	E. T. Fairchild.
New Jersey.....	Rutgers Scientific School (The New Jersey State College for the Benefit of Agriculture and the Mechanic Arts).	New Brunswick.....	W. H. S. Demarest.
New Mexico.....	New Mexico College of Agriculture and Mechanic Arts.	State College.....	W. E. Garrison.

<sup>1</sup> Dean.

<sup>2</sup> Acting president.

<sup>3</sup> Does not maintain courses in agriculture.

<sup>4</sup> Director.

*Agricultural colleges in the United States—Continued.*

State or Territory.	Name of institution.	Location.	President.
New York.....	New York State College of Agriculture at Cornell University.	Ithaca.....	L. H. Bailey. <sup>1</sup>
North Carolina.....	The North Carolina College of Agriculture and Mechanic Arts.	West Raleigh.....	D. H. Hill.
	The Agricultural and Mechanical College for the Colored Race.	Greensboro.....	J. B. Dudley.
North Dakota.....	North Dakota Agricultural College.	Agricultural College.....	J. H. Worst.
Ohio.....	College of Agriculture of the Ohio State University.	Columbus.....	H. C. Price. <sup>2</sup>
Oklahoma.....	Oklahoma Agricultural and Mechanical College.	Stillwater.....	J. H. Connell.
	Agricultural and Normal University.	Langston.....	I. E. Page.
Oregon.....	Oregon State Agricultural College.	Corvallis.....	W. J. Kerr
Pennsylvania.....	The Pennsylvania State College.	State College.....	E. E. Sparks.
Porto Rico.....	College of Agriculture and Mechanic Arts of the University of Porto Rico.	Mayaguez.....	F. L. Stevens. <sup>2</sup>
Rhode Island.....	Rhode Island State College.....	Kingston.....	Howard Edwards.
South Carolina.....	The Clemson Agricultural College of South Carolina.	Clemson College.....	W. M. Riggs.
	The Colored Normal, Industrial, Agricultural, and Mechanical College of South Carolina.	Orangeburg.....	R. S. Wilkinson.
South Dakota.....	South Dakota State College of Agriculture and Mechanic Arts.	Brookings.....	Robert L. Slagle.
Tennessee.....	College of Agriculture of the University of Tennessee.	Knoxville.....	Brown Ayers.
Texas.....	Agricultural and Mechanical College of Texas.	College Station.....	R. T. Milner.
	Prairie View State Normal and Industrial College.	Prairie View.....	E. L. Blackshear.
Utah.....	The Agricultural College of Utah.	Logan.....	J. A. Widtsoe.
Vermont.....	College of Agriculture of the University of Vermont.	Burlington.....	J. L. Hills. <sup>2</sup>
Virginia.....	The Virginia Agricultural and Mechanical College and Polytechnic Institute.	Blacksburg.....	P. B. Barringer.
	The Hampton Normal and Agricultural Institute.	Hampton.....	H. B. Frissell.
Washington.....	State College of Washington.....	Pullman.....	E. A. Bryan.
West Virginia.....	College of Agriculture of West Virginia University.	Morgantown.....	E. D. Sanderson. <sup>2</sup>
	The West Virginia Colored Institute.	Institute.....	Byrd Prillerman.
Wisconsin.....	College of Agriculture of the University of Wisconsin.	Madison.....	H. L. Russell. <sup>2</sup>
Wyoming.....	College of Agriculture and Mechanic Arts of the University of Wyoming.	Laramie.....	C. A. Duniway.

<sup>1</sup> Director.<sup>2</sup> Dean.**AGRICULTURAL EXPERIMENT STATIONS OF THE UNITED STATES, THEIR LOCATIONS AND DIRECTORS.**

Alabama (College), Auburn: J. F. Duggar.	Idaho, Moscow: W. L. Carlyle.
Alabama (Canebrake), Uniontown: L. H. Moore.	Illinois, Urbana: E. Davenport.
Alabama (Tuskegee), Tuskegee Institute: G. W. Carver.	Indiana, Lafayette: Arthur Goss.
Alaska, Sitka (Rampart, Kodiak, and Fairbanks) C. C. Georgeson. <sup>1</sup>	Iowa, Ames: C. F. Curtiss.
Arizona, Tucson: R. H. Forbes.	Kansas, Manhattan: W. M. Jardine. <sup>3</sup>
Arkansas, Fayetteville: C. F. Adams.	Kentucky, Lexington: J. H. Kastle.
California, Berkeley: T. F. Hunt.	Louisiana (Sugar), New Orleans
Colorado, Fort Collins: C. P. Gillette.	Louisiana (State), Baton Rouge
Connecticut (State), New Haven	Louisiana (North), Calhoun.....
Connecticut (Storrs), Storrs.....	Louisiana (Rice), Crowley.....
	Maine, Orono: C. D. Woods.
Delaware, Newark: Harry Hayward.	Maryland, College Park: H. J. Patterson.
Florida, Gainesville: P. H. Rolfs.	Massachusetts, Amherst: F. W. Morse. <sup>3</sup>
Georgia, Experiment: M. V. Calvin.	Michigan, East Lansing: R. S. Shaw.
Guam: <sup>2</sup> J. B. Thompson. <sup>1</sup>	Minnesota, University Farm, St. Paul: A. F. Woods.
Hawaii (Federal), Honolulu: E. V. Wilcox. <sup>1</sup>	Mississippi, Agricultural College: E. R. Lloyd.
Hawaii (Sugar Planters'), Honolulu: C. F. Eckart.	Missouri (College), Columbia: F. B. Mumford.

<sup>1</sup> Special agent in charge.<sup>2</sup> Address: Island of Guam, via San Francisco.<sup>3</sup> Acting director.

- Missouri (Fruit), Mountain Grove: Paul Evans.  
 Montana, Bozeman: F. B. Linfield.  
 Nebraska, Lincoln: E. A. Burnett.  
 Nevada, Reno: G. H. True.  
 New Hampshire, Durham: J. C. Kendall.  
 New Jersey (State), New Brunswick } J. G. Lipman.  
 New Jersey (College), New Brunswick }  
 New Mexico, State College: Fabian Garcia.  
 New York (State), Geneva: W. H. Jordan.  
 New York (Cornell), Ithaca: L. H. Bailey.  
 North Carolina (College), West Raleigh } B. W. Kil-  
 North Carolina (State), Raleigh } gore.  
 North Dakota, Agricultural College: J. H. Worst.  
 Ohio, Wooster: C. E. Thorne.  
 Oklahoma, Stillwater: J. A. Wilson.  
 Oregon, Corvallis: J. Withycombe.  
 Pennsylvania, State College: R. L. Watts.
- Pennsylvania (Institute of Animal Nutrition), State College: H. P. Armsby.  
 Porto Rico (Federal), Mayaguez: D. W. May.<sup>1</sup>  
 Porto Rico (Sugar), Rio Piedras: J. T. Crawley.  
 Rhode Island, Kingston: B. L. Hartwell.  
 South Carolina, Clemson College: J. N. Harper.  
 South Dakota, Brookings: J. W. Wilson.  
 Tennessee, Knoxville: H. A. Morgan.  
 Texas, College Station: B. Youngblood.  
 Utah, Logan: E. D. Ball.  
 Vermont, Burlington: J. L. Hills.  
 Virginia (College), Blacksburg: S. W. Fletcher.  
 Virginia (Truck), Norfolk: T. C. Johnson.  
 Washington, Pullman: R. W. Thatcher.  
 West Virginia, Morgantown: E. D. Sanderson.  
 Wisconsin, Madison: H. L. Russell.  
 Wyoming, Laramie: H. G. Knight.

## STATE OFFICIALS IN CHARGE OF AGRICULTURE.

- Alabama: Commissioner of Agriculture, Montgomery.  
 Alaska: Special Agent in Charge of Experiment Stations, Sitka.  
 Arizona: Director of Experiment Station, Tucson.  
 Arkansas: Commissioner of Agriculture, Little Rock.  
 California: Secretary of State Board of Agriculture, Sacramento.  
 Colorado: Secretary of State Board of Agriculture, Fort Collins.  
 Connecticut: Secretary of State Board of Agriculture, Hartford.  
 Delaware: Secretary of State Board of Agriculture, Dover.  
 Florida: Commissioner of Agriculture, Tallahassee.  
 Georgia: Commissioner of Agriculture, Atlanta.  
 Hawaii: Secretary of Territorial Board of Agriculture, Honolulu.  
 Idaho: Commissioner of Immigration, Labor, and Statistics, Boise.  
 Illinois: Secretary of State Board of Agriculture, Springfield.  
 Indiana: Secretary of State Board of Agriculture, Indianapolis.  
 Iowa: Secretary of State Board of Agriculture, Des Moines.  
 Kansas: Secretary of State Board of Agriculture, Topeka.  
 Kentucky: Commissioner of Agriculture, Frankfort.  
 Louisiana: Commissioner of Agriculture, Baton Rouge.  
 Maine: Commissioner of Agriculture, Augusta.  
 Maryland: Director of Experiment Station, College Park.  
 Massachusetts: Secretary of State Board of Agriculture, Boston.  
 Michigan: Secretary of State Board of Agriculture, East Lansing.  
 Minnesota: Secretary of State Agricultural Society, St. Paul.  
 Mississippi: Commissioner of Agriculture, Jackson.  
 Missouri: Secretary of State Board of Agriculture, Columbia.  
 Montana: Commissioner of Agriculture, Helena.
- Nebraska: Secretary of State Board of Agriculture, Lincoln.  
 Nevada: Secretary of State Board of Agriculture, Carson City.  
 New Hampshire: Secretary of State Board of Agriculture, Concord.  
 New Jersey: Secretary of State Board of Agriculture, Trenton.  
 New Mexico: Director of Experiment Station, Agricultural College.  
 New York: Commissioner of Agriculture, Albany.  
 North Carolina: Commissioner of Agriculture, Raleigh.  
 North Dakota: Commissioner of Agriculture, Bismarck.  
 Ohio: Secretary of State Board of Agriculture, Columbus.  
 Oklahoma: President of State Board of Agriculture, Oklahoma.  
 Oregon: Secretary of State Board of Agriculture Salem.  
 Pennsylvania: Secretary of Agriculture, Harrisburg.  
 Philippine Islands: Director of Agriculture, Manila.  
 Porto Rico: Director of Experiment Station, Mayaguez.  
 Rhode Island: Secretary of State Board of Agriculture, Providence.  
 South Carolina: Commissioner of Agriculture, Columbia.  
 South Dakota: Secretary of State Board of Agriculture, Huron.  
 Tennessee: Commissioner of Agriculture, Nashville.  
 Texas: Commissioner of Agriculture, Austin.  
 Utah: Director of Experiment Station, Logan.  
 Vermont: Commissioner of Agriculture, Plainfield.  
 Virginia: Commissioner of Agriculture, Richmond.  
 Washington: Director of Experiment Station, Pullman.  
 West Virginia: Secretary of State Board of Agriculture, Charleston.  
 Wisconsin: Secretary of State Board of Agriculture, Madison.  
 Wyoming: Director of Experiment Station, Laramie.

<sup>1</sup> Special agent in charge.

## REVIEW OF WEATHER CONDITIONS DURING THE YEAR 1912.

By P. C. DAY, *Climatologist and Chief of Division, Weather Bureau.*

The following summary of the weather for 1912 conforms largely with that appearing in the several numbers of the National Weather Bulletin, issued by months during January, February, March, October, November, and December, and by weeks during the principal crop-growing period, April to September, inclusive.

The most important departure of weather conditions from the normal for the year 1912 was the unusually severe cold that prevailed during the first three months in the districts to the eastward of the Rocky Mountains. Extreme cold was not more marked than has occurred in previous years, but for length of time during which severe cold was almost continuous the months of January, February, and March, 1912, are probably unsurpassed during the past 40 years. The period was especially cold in the central valleys and Lake region, and the amount of ice that formed on the rivers and lakes of those districts was far in excess of the normal, and in the Great Lakes region especially the ice was reported as being the heaviest within its recorded history.

Following close upon the record-breaking cold of the first three months of the year heavy rains and snows during the latter part of March and early April in the drainage basins of the Ohio and middle Mississippi Valleys, together with the rapid melting of a considerable body of snow already on the ground and the deeply frozen condition of the soil, caused one of the worst floods in the history of these rivers. Much land was overflowed in the lower Mississippi Valley and millions of dollars worth of property was destroyed.

The unfavorable weather of the winter greatly injured the winter-wheat crop in some of the States of the Ohio Valley, and the resulting yield at the time of harvest was in large areas scarcely 50 per cent of the usual crop. Good yields, however, in the States to the westward of the Mississippi River and in the spring-wheat States brought the total wheat crop up to the usual amount.

The distribution of the rainfall during the spring and summer months was favorable for corn and other cereals, and the ideal weather conditions attending their ripening enabled the gathering of crops that on the whole were among the greatest on record.

### JANUARY.

**TEMPERATURE.**—The month began with cold weather over the Northwest, the center of lowest temperature overlying the Valley of the Red River of the North, while in the far Southwest the unusual cold that had prevailed during the latter part of the preceding month continued.

With slight variations the weather continued to grow colder until about the 7th of the month, when the entire country to the eastward of the Rocky Mountains was in the grip of an unusually severe cold wave, the temperatures over the Great Plains from Kansas to the Dakotas and thence eastward to the Great Lakes and Ohio Valley ranging from 20° to 40° below the normal. With but slight interruptions severe cold continued till about the middle of the month, during which time the minimum temperatures approached and in some cases exceeded the lowest recorded at any time during the preceding 40 years.

During the latter half of the month there was a reaction to somewhat warmer weather over the southern and western districts, but it continued cold throughout the month from the upper Mississippi Valley eastward to New England and southeastward to the middle Atlantic coast.

During the prevalence of this severe cold over the United States and the Canadian Northwest Provinces the temperatures in Alaska were remarkably high; in fact, save on a few dates they were much higher than at points in the States.

PRECIPITATION.—The precipitation was generally light, except over the East Gulf and South Atlantic States and in the far Northwest, where the fall was somewhat above normal. In the West Gulf States and thence northeastward to the Lake region there was a very general deficiency of from 1 to 2 inches or more, and there was a large deficiency over southern California and other portions of the far Southwest.

SNOW.—There was generally less than the average snowfall in the upper Ohio Valley and North Atlantic States, but the amounts were quite heavy in portions of the Plains region and middle Mississippi and lower Ohio Valleys, while in the mountain districts of the West there was nearly everywhere a general deficiency, which was most pronounced in California and the Southwest.

#### FEBRUARY.

TEMPERATURE.—Continued cold was the rule during the first half of February, freezing weather extending into the Gulf coast region and the Florida Peninsula during the 5th to 7th, and destructive frosts in southern Florida being only averted by the timely occurrence of clouds and rain. Severe cold again prevailed from the Missouri and Mississippi Valleys eastward by the 9th, continuing several days and again extending to the Gulf coast and the Florida Peninsula.

The average temperature for the first 14 days of the month over the districts from the Rocky Mountains eastward was, as in January, far below the normal. To the westward of the mountains, however, the temperatures were more moderate, and in the extreme Northwest the period was considerably warmer than the average.

The latter half of the month was more moderate as to temperature, except that at the close a cold wave of considerable severity had overspread the central valleys and more northern districts. The temperatures in Alaska continued unusually high; in fact on but few days of the month, from observations made about 6 p. m., local time, were the temperatures below zero, and in the very heart of the Territory, near the Arctic Circle, they were frequently well above that point.

PRECIPITATION.—As in January the precipitation was generally light over much of the country. The first two decades of the month were unusually free from severe storms, and it was not until about the 20th to 22d that any general storm prevailed. This storm moved from the west Gulf and southern Plains region to the Ohio Valley, lower Lake region, and New England, accompanied by rains in the southern and snows in the northern sections of the country to the eastward of the Mississippi. A second storm moved over nearly the same course from the 25th to 27th, with some heavy snow from the middle Rocky Mountains and northern Texas eastward to lower Michigan, and heavy rains in the Ohio Valley, Middle Atlantic States, and New England.

To the westward of the Rocky Mountains generally dry weather continued, especially over California and the Southwest, where the season to date was among the driest of record.



**SNOW.**—At the close of the month there was a considerable body of snow on the ground from western Kansas and eastern Colorado northeastward to the Lake region and over northern New York and much of New England, but elsewhere east of the Rocky Mountains there was but a light covering.

In the central Rocky Mountain region there was considerable snow, and nearly the normal amounts were stored in the mountains of Montana and Idaho; but elsewhere in the western mountain districts there was less snow than usual, and in California and the States of the far Southwest the deficiency of snow in the mountains was unusually great.

#### MARCH.

**TEMPERATURE.**—The month opened with a cold wave of considerable severity over the central valleys and northern districts, but to the westward of the Rocky Mountains more moderate temperatures prevailed. Unusually cold weather continued in the interior portions of the country with but few interruptions throughout the first half of the month, and it was generally cold in most other districts, except over the Florida Peninsula and in the far Northwest, where the first half of the month was as warm as or slightly warmer than the average.

Over the eastern slope of the Rocky Mountains, and generally in the Great Plains and middle Mississippi Valley regions, the first half of the month was remarkable for the long duration and severity of the cold, the average departure of the mean temperature for the period from the normal ranging from  $-10^{\circ}$  to  $-15^{\circ}$  per day.

During the second half of the month some severe cold occurred about the 19th to 23d, and again at the end of the month over the interior and northern districts, and it was cool in other districts also, but the temperatures were not abnormally low.

For the month as a whole the temperature averaged unusually low from the Rocky Mountains to the Mississippi and Ohio Valleys, and in portions of the Great Plains region it was one of the coldest months of its name in many years.

**PRECIPITATION.**—Unlike the two preceding months, March had abundant precipitation in nearly all districts. Heavy rains occurred during the early part of the month in central and southern California, and rain and snow were more or less frequent during the same period over much of the Southwest.

No less than five general storms having their origin in the Southwest moved across the lower Mississippi and Ohio Valleys during the month, accompanied as a rule by heavy precipitation. As a result there was an excess of from 2 to 4 inches or more above the average precipitation over a large area, embracing nearly the entire central and southern portions of the country, and nearly all streams to the eastward of the Rocky Mountains were more or less in flood at some period during the month.

The most severe floods were in the Ohio and middle and lower Mississippi Valleys, where much land was overflowed and immense damage resulted. The flood in the lower Ohio and middle and lower Mississippi Rivers was still in progress at the end of the month, with every prospect that the stages reached would be the highest ever recorded.

**SNOW.**—The amount of snow was much below the normal fall for March over nearly all northern districts, especially in the upper Lake region and upper Mississippi Valley. On the other hand, snow was unusually heavy in portions of the middle Plains region and lower Missouri and middle Mississippi Valleys. In fact the snowfall over the greater portion of Kansas, Nebraska, Iowa, and

Missouri was the heaviest that has occurred in March for the past 30 years or more.

The ice in the Missouri and Mississippi Rivers and their tributaries broke up and moved out as a rule during the latter part of the month, and similar conditions prevailed in the navigable streams of the north Atlantic coast.

In the Lake region the harbors continued heavily icebound at the end of the month, and there were but few signs of the ice breaking up in the open lakes.

#### APRIL.

TEMPERATURE.—Along the northern border from the Lake region to New England, and in portions of the Great Plains, the first of the month was cold, but over the remaining districts moderately warm weather had set in, which gradually overspread the entire country till about the end of the first decade. Cold weather for the season then developed in the far Northwest, and during the following few days it overspread the districts to the eastward and southward, and some unusually low temperatures occurred in California and the Southwest about the 12th. This cold area gradually spread over the districts to the eastward of the Rocky Mountains, reaching the Atlantic coast about the 20th, and causing freezing temperatures or lower as far south as Kansas and in the mountain districts of Arizona and New Mexico, and frosts in Tennessee and northern Georgia.

During the first 15 days the average temperature was above the normal over all districts from the Rocky Mountains eastward, except in New England and portions of New York, where the period was moderately cold. It was colder than the average also in the far Southwest and over the entire Pacific coast section.

During the latter part of the month the weather continued cold in the districts to the westward of the Mississippi, and frosts and freezing temperatures prevailed in the Rocky Mountain and Great Plains regions. Over the Southern States and along the Atlantic coast the latter half of the month was moderately warm.

PRECIPITATION.—The general rainy condition that prevailed over the more southern districts during March continued into April, and heavy rains occurred near the beginning of the month in the watersheds of the Ohio and lower Mississippi Rivers, further augmenting the flood conditions that prevailed in those rivers at the end of March.

During the remainder of the month rainfall was frequent and in many sections of the great cereal and cotton-producing States the continued wet and cold condition of the soil greatly interfered with farming operations and delayed the development of vegetation. The precipitation over the central valleys and Gulf States was far above the average, and floods of moderate character prevailed in many of the rivers of the region referred to.

SNOW.—Some heavy snows occurred during the early part of the month in portions of New York and New England, and there was a heavy fall in portions of eastern Iowa and the adjoining parts of Illinois and Wisconsin on the 17th and 18th, the depth reaching more than 1 foot at points in northern Illinois.

The snowfall in the mountain regions of the West was heavy in the more northern districts and moderate in other portions. The generally cool weather during the month prevented any rapid melting of the snow stored in the high mountains, and the outlook for water for irrigation was somewhat improved, despite the general deficiency in the winter's supply in many localities.

## MAY.

**TEMPERATURE.**—During the first two weeks of May the temperature conditions over the eastern half of the country were the most favorable of the season to that time. Over the western districts, especially in the Rocky Mountain region, the first half of the month continued cold and backward.

Near the middle of the month an extensive area of cold overspread the Rocky Mountain and Great Plains regions, and freezing temperatures occurred at exposed points in those localities. The cold extended eastward into the central valleys and eastern districts, and the temperatures of the third week of the month were decidedly low as a whole throughout these districts. To the westward of the mountains the third week of the month was fairly warm, especially over the far Northwest, and on the whole it was the most favorable since the beginning of the season. The last week of the month was generally warm and favorable over all districts to eastward of the Rocky Mountains, but to the westward cold weather again prevailed, causing some damage to fruit and still further delaying vegetable growth.

**PRECIPITATION.**—Moisture was generally well distributed through the different periods of the month, although it was more abundant during the first half than during the latter part. Some delay in farm work occurred on account of the wet condition of the soil in the great corn-growing States to the eastward of the Mississippi and also in the middle portion of the cotton belt, but the drier weather of the latter half was very beneficial and permitted of much outdoor work, while the warm weather and sunshine rapidly advanced vegetation. The flood conditions prevalent in April were greatly relieved during the month, and most streams had returned to moderate stages by the end of the month, except the lower Mississippi, which was still in flood at the end of the month.

**SNOW.**—Some snow fell in the lower Lake region and northern portions of New York and New England on the 13th and 20th, and moderate amounts fell in the central and northern portions of the mountain regions of the West.

## JUNE.

**TEMPERATURE.**—The first few days of the month were warm and favorable in nearly all districts, and some unusually high temperatures were reported from California and the far Southwest, and at the same time it was quite warm over the North Atlantic States. Beginning about the 5th, a cool area overspread the Northwest, and during the next two weeks temperatures far below the normal prevailed over much of the country to the eastward of the Rocky Mountains, and toward the latter part of the period the cold area had extended to nearly all portions of the country. During this period minimum temperatures were unusually low over much of the eastern portion of the country and heavy frosts occurred at points in New York and New England and in the upper Missouri Valley and other portions of the Northwest.

During the last week of the month a change to warmer weather occurred over the northern districts, and high temperatures prevailed in the Missouri and upper Mississippi Valleys, but over the southern districts it remained cool, and similar conditions prevailed over the Pacific Coast States.

For the month, as a whole, the temperature was considerably lower than the normal over all interior portions of the country as well as over most southern districts.

Over the Pacific Coast States the month was warmer than usual, and it was quite warm in the northern portions of the Mountain and Plateau regions.

**PRECIPITATION.**—The distribution of the rainfall during the month was timely, and it occurred in generous quantity in nearly all districts where rain is expected during June.

At the first of the month dry, hot winds over portions of the Great Plains region rapidly evaporated the moisture from the soil, and there was urgent need of rain in portions of Oklahoma and adjacent States by the end of the first decade. During this period some heavy rains occurred in the Southeastern States, especially in Georgia about the 7th or 8th, where they were excessive and injurious.

About the middle of the month heavy rains prevailed over the Great Plains region, and there were generous falls from the upper Missouri Valley westward to the Pacific coast, and moderate falls in many other portions of the country. In the North Atlantic States, however, there had been a general lack of rain which continued throughout the month, and at the end the surface soil had become quite dry in portions of New England and New York, and to a less extent in some of the States farther south.

Toward the end of the month dry weather had set in over the Great Plains region, and there was a general, though as yet not serious, lack of rainfall throughout nearly all the great cereal-growing States.

The month, as a whole, was generally favorable, and the moderate temperatures and lack of general rains during the latter part, with abundant sunshine, were unusually favorable for the ripening and harvesting of wheat and the development of plant growth.

#### JULY.

**TEMPERATURE.**—The warm weather prevalent over the northern districts from the Lake region westward to the mountains during the latter part of June continued during the first week of July, while to the westward of the mountains it continued abnormally cold, and it was generally cool over the Southeastern States.

During the second week warmer weather overspread most of the central and eastern districts, the day temperatures becoming decidedly high, and much inconvenience and suffering, as well as many deaths, resulted therefrom in the large cities of those districts. Cool weather still continued in the far western districts and over the Southeastern States.

About the middle of the third week a change to decidedly cooler weather occurred over the central and northern districts, affording much relief from the heat that had prevailed during the preceding week, but it continued warm over the south, and there was a general rise in temperature to the westward of the mountains.

The last week of the month was marked by generally high temperatures in the Great Plains, Mississippi Valley, and the Southern States from Texas eastward, but cool weather prevailed from the Lake region eastward to New England, and it was moderately cool in the Mountain and Plateau regions of the West.

**PRECIPITATION.**—The drought prevailing in the north Atlantic States at the end of June continued into the second week of July, and high temperatures and drying winds greatly increased its severity and threatened an almost complete loss of the staple crops. Fortunately rain at intervals during the second decade of the month relieved the conditions, especially in New England, but the latter part of the month was again dry, and at the close rain was badly needed in portions of New York and Virginia.

Over the great cereal-growing States the rainfall was sufficient, as a rule, for the needs of growing vegetation, although to the westward of the Missis-

Mississippi there were periods when rain was needed, especially in Oklahoma, northern Texas, and portions of adjoining States. The absence of general rains was favorable for harvesting the winter-wheat crop, and there was generally sufficient moisture in the soil in the more northern districts to insure the proper development and ripening of the spring-wheat crop.

In the cotton region there was rather too much cool, rainy weather during the early part of the month in the middle Gulf States, and dry weather prevailed in the more western portions, but timely showers relieved the drought conditions locally, and during the latter part of the month the warmer and drier weather in the central portions of the belt was generally favorable.

#### AUGUST.

TEMPERATURE.—During the first and second weeks of August cold weather for the period of the year prevailed in all districts, save along the Gulf coast and over portions of the Southwest, and occasionally along the immediate Pacific coast.

Throughout the great cereal-growing States the temperatures during this period were nearly continuously below the normal, and on the mornings of the 4th and 5th they were as low as, or lower than, ever before recorded in the first decade of August at numerous points from the middle and lower Mississippi Valley eastward to the Atlantic coast.

The mean temperature for the first week ranged from 9° to 12° per day below the normal over large portions of the Mississippi and Ohio Valleys, Lake region, and Atlantic coast States, and during the second week they were more than 6° below over much of the same region.

During the third week of August there was a general warming up in the districts to the eastward of the Rocky Mountains, and conditions became much more favorable for crop growth over the great corn-growing districts. To the westward of the mountains, however, the weather continued cool, the deficiency exceeding 6° per day in the far Northwest.

The last week of the month continued warm over the great agricultural districts, and there was a general rise in the temperature to normal, or slightly above, in the districts to the westward of the mountains, where temperatures generally below the normal had prevailed since early in June.

During the last day or two of the month cold weather overspread the northern and central districts, and the lowest August temperatures in many years were reported from portions of New York and New England, and abnormally cold weather for the season prevailed in the Rocky Mountain and Plateau regions, with frosts at exposed points.

PRECIPITATION.—Unusually heavy rains for the season and locality occurred during the first few days of the month in portions of the Rocky Mountain and Plateau regions, but over much of the great cereal-growing sections there was little or no rain. About the 10th general rains set in over the Plains region, and gradually overspread the districts to the eastward, and good rains thoroughly saturated the soil in the principal corn-growing States, as well as in the cotton region; in fact, all portions of the country from the middle Plains region eastward received generous amounts, except along the middle Atlantic coast.

During the third week rain again occurred in moderate amounts over the western part of the corn belt and generally throughout the northern and central Mountain and Plateau districts of the West. In the more eastern portions, especially in the Appalachian Mountain regions, there was but little rain during this period, and only small amounts occurred in the western portions of the cotton region.

There was a considerable deficiency in precipitation during the last two weeks of the month, but the warm weather and moist condition of the soil during this period were very favorable for all vegetable growth, and only in small sections were conditions unfavorable until near the end, when the continued absence of rain caused some apprehension regarding the cotton crop in the extreme western and extreme eastern portions of the cotton region.

#### SEPTEMBER.

TEMPERATURE.—The warm weather prevailing at the close of August in most southern and central portions of the country east of the Rocky Mountains early in September replaced the cooler weather in the Lake region and north-eastern States, and in the central valleys became even more intense, so that many stations in Illinois and adjacent States recorded the highest temperatures of the summer at this time. Meanwhile in most of the country to westward of the Rockies cool weather for the season was prevailing, and about the 12th the cool area extended over the northern Plains States and thence eastward over the northern and central districts to the Lake region and the central valleys. Frosts were recorded at this time in Minnesota, the Dakotas, and the northern and central Rocky Mountain States, but the damage was not very great to the eastward. In the more eastern districts the abnormal warmth continued, and before the middle of the month warm weather set in along the Pacific coast.

After the 16th the cooler weather in the Great Plains and Rocky Mountain region gradually intensified and spread still farther to the eastward and southward. During the last week of September cool weather reached the north-eastern States, with some frost, but generally little damage resulting. About the same time severe frosts visited much of Illinois, Iowa, and Nebraska, and generally killing frost occurred in the States to northward and northwestward, where, however, it was not unseasonably early for such an event.

For September as a whole the average temperature was nearly everywhere above normal to eastward of the Mississippi River, with a most notable excess, 4° or more, in the central Appalachian region. In the west Gulf States and the western portions of the Pacific States the mean temperature of the month was also above normal. In the Plains, Rocky Mountain, and Plateau regions September was cooler than normal, especially in the northern and central Mountain region and the northern Plains region, where the deficiency averaged about 8° per day. Indeed, if merely the last 20 days of the month are considered, the mean temperature in most of the Missouri Valley was from 10° to 15° below the normal for the period.

PRECIPITATION.—Rains occurred on the opening days in most of the Middle Atlantic States and the upper Ohio Valley, with remarkably heavy local downpours in the southwestern counties of Pennsylvania and neighboring parts of Ohio and West Virginia on the night of September 1, occasioning great damage and the loss of a number of lives. During the next few days there were important rains in northern California, the upper Lake region, and a large part of central and northeastern Florida with the coast regions of Georgia and South Carolina. About the 9th to 16th precipitation occurred in large amount over a considerable area in the central Plains region, also southwestward over the Texas Panhandle and much of New Mexico, and northwestward over much of Wyoming, which experienced a snowstorm unprecedented for September. About the 13th to 15th a storm moved northward from the Gulf of Mexico over Alabama to the lower Ohio Valley, giving usually moderate rains, but here and there quite heavy falls.

During the last fortnight of September there was fairly generous precipitation in most northern districts between the Great Lakes and the Rocky Mountains; also over most of Missouri and Arkansas, southwestern Texas, and practically all the country east of the Mississippi River there were good rains, the falls in the last-named being largely in connection with a storm which moved from western Florida to Chesapeake Bay from the 23d to 25th.

Taking September as a whole the rainfall was ample in almost all parts of the Atlantic States, being decidedly heavy in southeastern Georgia and near the Gulf coast of Florida. Other regions of generous precipitation were northern Minnesota, most of North Dakota, portions of Iowa, and the Texas Panhandle. In the Far West the month brought fair rains along the immediate Pacific coast from San Francisco northward, and larger amounts in some interior parts of northern California.

The warmth of early September in the great corn-growing States hastened the maturing of that staple, but the cold weather after the 10th in the Missouri and upper Mississippi Valleys was unfavorable. To eastward of the Mississippi River the month, as a whole, was usually a favorable one.

#### OCTOBER.

TEMPERATURE.—The coolness in the central and upper valleys, Lake region and Northeastern States when September closed was soon succeeded by warmer weather; and thereafter, save for periods of a few days never really notable, almost all the eastern half of the country experienced temperatures higher than normal. In the western half of the country cool weather prevailed during the first third of the month, but warmer than normal during the middle third, except that cool weather then prevailed in the southern portions of the Great Plains and Rocky Mountain regions and in the West Gulf States. The final third of October was colder than normal in northern districts from the upper Lake region westward to the Pacific, throughout the Pacific Coast States, in the far Southwest, and in the central portions of the Plains, Rocky Mountain and Plateau regions. As a whole, the month was warmer than normal nearly everywhere east of the Rocky Mountains, also along the immediate Pacific coast from central California southward it was close to or slightly above normal as to temperature. In the Plateau region, the north Pacific States, and the interior of southern California the month averaged somewhat cooler than normal.

PRECIPITATION.—Among the more notable rain areas during October were that which accompanied the storm moving from the Southwest to the Lake region between the 10th and 12th, that which visited southwestern Texas about the 16th, when a storm moved inland from the Gulf of Mexico, and the one accompanying the storm which moved from the central Rocky Mountain region on the 27th to beyond Lake Superior on the 29th. The precipitation of October was fairly well distributed and generally sufficient. Regions of scanty fall, however, covered a district extending from Maryland southward to eastern South Carolina, most of the lower Mississippi Valley, the greater part of South Dakota, Minnesota, and northern Wisconsin, and most of central and southern California.

The sunshiny and warm weather abundant to eastward of the Rocky Mountains during October was favorable for fall work, and the absence of damaging frosts till the middle or later portions of the month in most eastern districts was highly favorable for late vegetation. In the Rocky Mountain States and to westward October weather was less favorable, and coolness and rain were rather too prevalent, except in California.

## NOVEMBER.

TEMPERATURE.—Early in November a cool area from the Rocky Mountain and Plains regions spread southward and eastward, causing frosts in most of Texas and the other Gulf States. Warmer weather set in behind this, so that the opening third of the month averaged warmer than normal save in the Southeastern States and lower Mississippi Valley. During the middle portion of the month the weather was warmer than normal in practically all parts of the country, and remarkably warm in the Missouri and upper Mississippi Valleys. About the 25th, however, this warmth largely yielded to a cold area which overspread most eastern and southern districts, freezing weather reaching into extreme northern Florida. As the month was ending another cold area moved from the far Northwest into Texas and the middle and eastern Gulf States, bringing killing frost almost to the Gulf coast. The temperatures of the final third of November averaged higher than normal in practically all northern districts, and generally to westward of the Rocky Mountains; but lower than normal in substantially all the cotton region.

November as a whole was warmer than normal in much the greater part of the country, and the departure was marked in the middle and upper Missouri Valley. In much of the cotton region and in portions of New Mexico and California the month averaged somewhat cooler than normal.

PRECIPITATION.—November was comparatively free from the storms usual at the season, though one storm which moved from the Lake region to the St. Lawrence Valley on the 1st and 2d caused rain in most eastern districts, and a storm which moved northward from the south Atlantic coast to New England on the 27th and 28th caused rain and snow in most coast States, the snowfall being unusually heavy for the season in most of Georgia and the Carolinas.

As a whole November showed a decided deficiency in precipitation. The lightness of the rainfall in the Ohio and lower Mississippi Valleys was especially notable, while most of South Dakota and considerable parts of the Southwest received no rain or snow whatever. Precipitation was somewhat above normal, however, over much of New York, a considerable area in the South Atlantic and east Gulf States, the central Plateau district, and western Oregon.

SNOW.—In most western districts the snowfall in the mountains was remarkably light, but parts of New York and New England had some heavy falls for November.

As a whole the month was a favorable one for farm work, but the small amount of moisture over large areas probably retarded the development of winter wheat.

## DECEMBER.

TEMPERATURE.—The cool weather in most eastern districts when November ended soon gave way to warmth, and thereafter, although conditions were changeable, temperatures above normal generally prevailed to eastward of the Rocky Mountains. About the 5th and 6th it was decidedly warm in the Atlantic coast and Lake regions. To westward of the Rocky Mountains the opening third of December was rather cool, also in the southern Plains region. During the middle and later portions of the month mild weather was the rule in the northern half of the country, but cool weather for December prevailed over most southern portions, especially to westward of the Mississippi River. The closing portion of the month was cool in the central Rocky Mountain and Plateau regions also.

The month considered as a whole was warmer than normal nearly everywhere eastward of the Mississippi River, and especially over the upper Mis-



Mississippi Valley and most of the Missouri Valley, where the last 10 days were remarkably warm for December. The average temperature was below normal in the western part of the cotton region and in California, and decidedly below normal in the districts between, namely, the central and southern portions of the Rocky Mountain and Plateau regions.

**PRECIPITATION.**—There was remarkably large rainfall during December in most of Louisiana and Mississippi, and it was rather heavy over an area to northward and northeastward of those States, as far as the Ohio River. There was more than normal precipitation over several other areas, as the greater part of Texas and southern New Mexico, the eastern part of the Middle Atlantic States and some other localities along the Atlantic coast, and much of the upper Lake region, the upper Mississippi Valley, and North Dakota. Considering the whole country, however, December was a dry month. In Missouri, Illinois, and California there was a notable deficiency of precipitation, amounting in many portions to an almost entire absence. The Appalachian and lower Lake regions and the central and northern Plains, Rocky Mountain and Plateau regions had almost everywhere less than normal precipitation.

**SNOW.**—In the western mountains the snowfall of December was almost everywhere quite light, though Oregon reported a heavy fall during the closing days. In northern districts to eastward of the Rockies the snowfall was nearly everywhere much less than usual for the month, and, owing to the mildness, that which did occur generally melted quite rapidly.

In most parts of the country December was a favorable month for outdoor work, save in the middle Gulf States, where it was marked by too much wet weather.

## STATISTICS OF THE PRINCIPAL CROPS.

[Figures furnished by the Bureau of Statistics, Department of Agriculture, except where otherwise stated.  
All prices are gold.]

## CORN.

TABLE 1.—*Corn area of countries named, 1908–1912.*

Country.	1908	1909	1910	1911	1912
NORTH AMERICA.					
United States.....	<i>Acres.</i> 101,788,000	<i>Acres.</i> 98,383,000	<i>Acres.</i> 104,035,000	<i>Acres.</i> 105,825,000	<i>Acres.</i> 107,083,000
Canada:					
Ontario.....	332,200	320,000	299,000	290,700	271,700
Quebec.....	33,600	32,200	29,100	25,300	21,000
Other.....				100	200
Total Canada.....				316,100	292,200
Mexico.....	(1)	(1)	13,375,400	(1)	(1)
SOUTH AMERICA.					
Argentina.....	6,719,300	7,348,500	7,425,400	7,945,100	8,455,800
Chile.....	63,100	62,000	51,800	45,800	(1)
Uruguay.....	431,200	502,300	534,400	498,400	(1)
EUROPE.					
Austria-Hungary:					
Austria.....	845,100	831,200	770,400	748,300	751,600
Hungary proper.....	5,831,000	6,061,300	5,997,500	6,090,000	6,022,500
Croatia-Slavonia.....	1,033,300	1,003,200	1,004,200	1,023,800	1,057,300
Bosnia-Herzegovina.....	702,900	529,900	494,200	509,900	(1)
Total Austria-Hungary.....	8,412,300	8,425,600	8,236,300	8,372,000	.....
Bulgaria.....	1,410,400	1,501,000	1,511,100	1,561,500	(1)
France.....	1,226,200	1,222,600	1,192,100	1,049,100	(1)
Italy.....	4,444,700	4,005,000	3,757,200	4,066,400	3,937,500
Portugal.....	(1)	(1)	(1)	(1)	(1)
Roumania.....	4,992,300	5,247,100	4,908,000	5,152,700	5,135,800
Russia:					
Russia proper.....	2,970,900	3,050,800	2,858,100	3,177,500	.....
Northern Caucasia.....	659,400	733,600	772,100	759,200	.....
Total Russia.....	3,630,300	3,784,400	3,630,200	3,936,700	2 4,086,000
Servia.....	1,392,600	1,445,900	1,446,100	1,443,200	(1)
Spain.....	1,133,300	1,149,100	1,121,600	1,145,100	1,149,100
ASIA.					
British India (including native States).....	6,296,400	6,784,200	6,857,900	6,311,600	(1)
Japan.....	128,700	120,300	130,600	129,400	(1)
Philippine Islands.....	(1)	(1)	1,432,600	(1)	(1)
AFRICA.					
Algeria.....	39,000	37,600	36,100	34,900	30,700
Egypt.....	1,865,000	1,910,600	1,840,000	1,902,700	(1)
Union of South Africa.....	(1)	(1)	(1)	(1)	(1)
AUSTRALASIA.					
Australia:					
Queensland.....	127,100	127,700	132,300	180,900	153,900
New South Wales.....	161,000	180,800	212,800	213,200	168,300
Victoria.....	10,900	14,000	19,100	20,200	18,200
Western Australia.....	200	200	.....	.....	.....
South Australia.....	.....	.....	200	600	(1)
New Zealand.....	8,900	11,500	12,500	13,100	6,100
Total Australasia.....	308,100	334,200	377,100	428,000	.....

1 No official statistics of area.

2 Includes Asiatic Russia (10 Governments of).

TABLE 2.—*Corn crop of countries named, 1908-1912.*

Country.	1908	1909	1910	1911	1912
<b>NORTH AMERICA.</b>					
	<i>Bushels.</i>	<i>Bushels.</i>	<i>Bushels.</i>	<i>Bushels.</i>	<i>Bushels.</i>
United States.....	2,668,651,000	2,552,190,000	2,886,260,000	2,531,488,000	3,124,746,000
Canada:					
Ontario.....	21,742,000	18,211,000	17,853,000	18,001,000	16,047,000
Quebec.....	1,126,000	1,047,000	860,000	766,000	514,000
Other.....	5,000	5,000	5,000	6,000	9,000
Total Canada.....	22,873,000	19,263,000	18,718,000	18,773,000	16,570,000
Mexico.....	150,000,000	170,000,000	190,766,000	190,000,000	.....
Total.....	2,841,524,000	2,741,453,000	3,095,744,000	2,740,261,000	.....
<b>SOUTH AMERICA.</b>					
Argentina.....	136,055,000	177,155,000	175,187,000	27,675,000	295,849,000
Chile.....	1,344,000	1,178,000	1,378,000	1,221,000	( <sup>1</sup> )
Uruguay.....	4,004,000	6,671,000	6,514,000	3,643,000	( <sup>1</sup> )
Total.....	141,403,000	185,004,000	183,079,000	32,539,000	.....
<b>EUROPE.</b>					
Austria-Hungary:					
Austria.....	15,170,000	15,657,000	16,823,000	11,856,000	15,053,000
Hungary proper.....	146,122,000	161,860,000	187,733,000	137,421,000	181,826,000
Croatia-Slavonia.....	20,536,000	21,752,000	25,589,000	24,005,000	24,166,000
Bosnia-Herzegovina.....	8,821,000	10,972,000	10,051,000	8,416,000	8,555,000
Total Austria-Hungary.....	190,649,000	210,241,000	240,196,000	181,698,000	229,600,000
Bulgaria.....	20,717,000	20,472,000	28,330,000	30,500,000	( <sup>1</sup> )
France.....	26,247,000	26,075,000	23,399,000	16,860,000	( <sup>1</sup> )
Italy.....	95,953,000	99,289,000	101,722,000	93,680,000	98,668,000
Portugal.....	15,000,000	15,000,000	15,000,000	15,000,000	( <sup>1</sup> )
Roumania.....	78,892,000	70,133,000	103,665,000	110,712,000	104,612,000
Russia:					
Russia proper.....	49,663,000	29,223,000	63,089,000	67,842,000	( <sup>1</sup> )
Northern Caucasia.....	11,449,000	10,375,000	14,093,000	14,087,000	( <sup>1</sup> )
Total Russia.....	61,112,000	39,598,000	77,182,000	81,919,000	<sup>2</sup> 79,964,000
Servia.....	21,010,000	34,453,000	33,204,000	26,531,000	( <sup>1</sup> )
Spain.....	20,115,000	26,433,000	27,366,000	28,730,000	25,069,000
Total.....	529,695,000	541,699,000	650,094,000	585,630,000	.....
<b>AFRICA.</b>					
Algeria.....	402,000	426,000	556,000	554,000	374,000
Egypt.....	65,000,000	65,000,000	70,294,000	67,903,000	69,913,000
Union of South Africa.....	20,000,000	20,000,000	20,000,000	20,000,000	( <sup>1</sup> )
Total.....	85,402,000	85,426,000	90,850,000	88,457,000	.....
<b>AUSTRALASIA.</b>					
Australia:					
Queensland.....	3,191,000	2,855,000	2,588,000	4,601,000	.....
New South Wales.....	4,671,000	5,380,000	7,322,000	7,833,000	.....
Victoria.....	525,000	671,000	1,195,000	1,013,000	.....
Western Australia.....	1,000	2,000	1,000	1,000	.....
South Australia.....	.....	.....	7,000	7,000	.....
Total.....	8,388,000	8,908,000	11,113,000	13,455,000	9,186,000
New Zealand.....	519,000	736,000	750,000	478,000	287,000
Total Australasia.....	8,907,000	9,644,000	11,863,000	13,933,000	9,473,000
Grand total.....	3,606,931,000	3,563,226,000	4,031,630,000	3,460,820,000	( <sup>3</sup> )

<sup>1</sup> No official data received.<sup>2</sup> Includes Asiatic Russia (10 Governments of).<sup>3</sup> Total of countries whence returns have been received in 1912 is 4,054,838,000 bushels, against 3,157,432,000 bushels for same countries in 1911.

TABLE 3.—Total production of corn in countries named in Table 2, 1894–1912.

Year.	Production.	Year.	Production.	Year.	Production.	Year.	Production.
	<i>Bushels.</i>		<i>Bushels.</i>		<i>Bushels.</i>		<i>Bushels.</i>
1894.....	1,671,307,000	1899.....	2,724,100,000	1904.....	3,109,252,000	1909.....	3,563,226,000
1895.....	2,834,750,000	1900.....	2,792,561,000	1905.....	3,461,181,000	1910.....	4,031,630,000
1896.....	2,964,435,000	1901.....	2,366,883,000	1906.....	3,963,645,000	1911.....	3,461,187,000
1897.....	2,587,206,000	1902.....	3,187,311,000	1907.....	3,420,321,000		
1898.....	2,682,619,000	1903.....	3,066,506,000	1908.....	3,606,931,000		

TABLE 4.—Acreage, production, value, and exports of corn, United States, 1849–1912

Year.	Acreage.	Average yield per acre.	Production.	Average farm price per bushel Dec. 1.	Farm value Dec. 1.	Chicago cash price per bushel, No. 2.				Domestic exports, including corn meal, fiscal year beginning July 1.	Per cent of crop exported.
						December.		May of following year.			
						Low.	High.	Low.	High.		
1849 <sup>1</sup>			592,071,000							7,632,880	1.3
1859 <sup>1</sup>			838,793,000							4,248,991	.6
1866..	34,307,000	25.3	867,946,000	47.4	411,451,000	53	62	64	79	16,026,947	1.8
1867..	32,520,000	23.6	768,320,000	57.0	437,770,000	61	65	61	71	12,493,522	1.6
1868..	34,887,000	26.0	906,527,000	46.8	424,057,000	38	58	44	51	8,286,665	.9
1869..	37,103,000	23.6	874,320,000	59.8	522,551,000	56	67	73	85	2,140,487	.2
1869 <sup>1</sup>			760,945,000								
1870..	38,647,000	28.3	1,094,255,000	49.4	540,520,000	41	59	46	52	10,673,553	1.0
1871..	34,091,000	29.1	991,898,000	43.4	430,356,000	36	39	38	43	35,727,010	3.6
1872..	35,527,000	30.8	1,092,719,000	35.3	385,736,000	27	28	34	39	40,154,374	3.7
1873..	39,197,000	23.8	932,274,000	44.2	411,961,000	40	49	49	59	35,985,834	3.9
1874..	41,037,000	20.7	850,148,000	58.4	496,271,000	64	76	53	67	30,025,036	3.5
1875..	44,841,000	29.5	1,321,069,000	36.7	484,675,000	40	47	41	45	60,910,532	3.9
1876..	49,033,000	26.2	1,283,828,000	34.0	436,109,000	40	43	43	56	72,652,611	5.7
1877..	50,369,000	26.7	1,342,558,000	34.8	467,635,000	41	49	35	41	87,192,110	6.5
1878..	51,585,000	26.9	1,388,219,000	31.7	440,281,000	30	32	33	36	87,884,892	6.3
1879..	53,085,000	29.2	1,547,902,000	37.5	580,486,000	39	43½	32½	36½	99,572,329	6.4
1879 <sup>1</sup>	62,869,000	28.1	1,754,592,000								
1880..	62,318,000	27.6	1,717,435,000	39.6	679,714,000	35½	42	41½	45	93,648,147	5.5
1881..	64,262,000	18.6	1,194,916,000	63.6	759,482,000	58½	63½	69	76½	44,340,683	3.7
1882..	65,660,000	24.6	1,617,025,000	48.5	783,867,000	49	61	53½	56½	41,655,653	2.6
1883..	68,302,000	22.7	1,551,067,000	42.4	658,051,000	54½	63½	52½	57	46,258,606	3.0
1884..	69,684,000	25.8	1,795,528,000	35.7	640,736,000	34½	40½	44½	49	52,876,456	2.9
1885..	73,130,000	26.5	1,936,176,000	32.8	635,675,000	36	42	34½	36½	64,829,617	3.3
1886..	75,694,000	22.0	1,665,441,000	36.6	610,311,000	35½	38	36½	39½	41,368,584	2.5
1887..	72,393,000	20.1	1,456,161,000	44.4	646,107,000	47	51½	54	60	25,360,869	1.7
1888..	75,673,000	26.3	1,987,790,000	34.1	677,562,000	33½	35½	33½	35	70,841,673	3.6
1889..	78,320,000	27.0	2,112,892,000	28.3	597,919,000	29½	35	32½	35½	103,418,709	4.9
1889 <sup>1</sup>	72,088,000	29.4	2,122,328,000								
1890..	71,971,000	20.7	1,489,970,000	50.6	754,433,000	47½	53	55	69½	32,041,529	2.2
1891..	76,205,000	27.0	2,060,154,000	40.6	836,439,000	39½	59	40½	100	76,062,285	3.7
1892..	70,627,000	23.1	1,628,464,000	39.4	642,147,000	40	42½	39½	44½	47,121,894	2.9
1893..	72,036,000	22.5	1,619,496,000	36.5	591,626,000	34½	36½	36½	38½	66,489,529	2.4
1894..	62,582,000	19.4	1,212,770,000	45.7	554,719,000	44½	47½	47½	55½	28,585,405	4.1
1895..	82,076,000	26.2	2,151,139,000	25.3	544,986,000	25	26½	27½	29½	101,100,375	4.7
1896..	81,027,000	28.2	2,283,875,000	21.5	491,007,000	22½	23½	23	25½	178,817,417	7.7
1897..	80,095,000	23.8	1,902,968,000	26.3	501,073,000	25	27½	32½	37	172,055,543	11.1
1898..	77,722,000	24.8	1,924,155,000	28.7	552,023,000	33½	38	32½	34½	177,255,046	9.2
1899..	82,109,000	25.3	2,078,144,000	30.3	629,210,000	30	31½	36	40	123,128,412	10.3
1899 <sup>1</sup>	94,914,000	28.1	2,066,324,000								
1900..	83,321,000	25.3	2,105,103,000	35.7	751,220,000	35½	40½	42½	58½	181,405,473	8.6
1901..	91,350,000	16.7	1,522,520,000	60.5	921,556,000	62½	67½	59½	64½	28,028,688	1.8
1902..	94,044,000	26.8	2,523,648,000	40.3	1,017,017,000	43½	57½	44	46	76,639,261	3.0
1903..	88,092,000	25.5	2,244,177,000	42.5	952,869,000	41	43½	47½	50	58,222,061	2.6
1904..	92,232,000	26.8	2,467,481,000	44.1	1,087,461,000	43	49	48	64	90,293,483	3.7
1905..	94,011,000	28.8	2,707,994,000	41.2	1,116,697,000	42	50½	47½	50	119,893,833	4.4
1906..	96,738,000	30.3	2,927,416,000	39.9	1,166,626,000	40	46	49½	56	86,368,228	3.0
1907..	99,931,000	25.9	2,592,320,000	51.6	1,336,901,000	50	61½	67½	82	55,063,860	2.1
1908..	101,788,000	26.2	2,668,651,000	60.6	1,616,145,000	56½	62½	72½	76	37,665,040	1.4
1909..	108,771,000	25.5	2,772,376,000	59.6	1,652,822,000	62½	66	56	63	38,128,498	1.5
1909 <sup>1</sup>	98,383,000	25.9	2,552,190,000								
1910 <sup>3</sup>	104,035,000	27.7	2,886,260,000	48.0	1,384,817,000	45	50	52½	55½	65,614,522	2.8
1911 <sup>3</sup>	105,825,000	23.9	2,531,488,000	61.8	1,565,258,000	68	70	76½	82½	41,797,291	1.7
1912 <sup>3</sup>	107,083,000	29.2	3,124,746,000	48.7	1,520,454,000	47½	54				

<sup>1</sup> Census figures.

<sup>2</sup> Coincident with "corner."

<sup>3</sup> Figures adjusted to census basis.

TABLE 5.—*Acres and production of corn, by States, 1909-1912.*

State and division.	Acreage (000 omitted).				Production (000 omitted).			
	1912	1911	1910	1909 (census.)	1912	1911	1910	1909 (census.)
	<i>Acres.</i>	<i>Acres.</i>	<i>Acres.</i>	<i>Acres.</i>	<i>Bush.</i>	<i>Bush.</i>	<i>Bush.</i>	<i>Bush.</i>
Maine.....	16	18	17	15	640	792	782	649
New Hampshire.....	23	23	22	20	1,058	1,035	1,012	916
Vermont.....	45	46	44	43	1,800	1,886	1,922	1,715
Massachusetts.....	47	47	45	42	2,115	2,068	2,048	2,029
Rhode Island.....	11	11	10	10	456	495	400	398
Connecticut.....	60	59	57	53	3,000	2,862	3,032	2,531
New York.....	512	530	525	512	19,763	20,405	20,108	18,116
New Jersey.....	273	270	267	265	10,374	9,936	9,612	10,001
Pennsylvania.....	1,449	1,435	1,430	1,381	61,582	63,858	58,630	41,494
N. Atlantic.....	2,436	2,439	2,417	2,341	100,788	103,337	97,516	77,849
Delaware.....	195	195	193	189	6,630	6,630	6,137	4,840
Maryland.....	670	670	660	647	24,455	24,455	22,110	17,924
Virginia.....	1,980	1,980	1,960	1,860	47,520	47,520	49,980	38,295
West Virginia.....	725	707	700	676	24,505	18,170	18,200	17,119
North Carolina.....	2,808	2,700	2,650	2,459	51,106	49,680	49,290	34,063
South Carolina.....	1,915	1,790	1,707	1,566	34,278	32,578	31,580	20,872
Georgia.....	3,910	3,692	3,585	3,383	53,958	59,072	51,982	39,375
Florida.....	655	636	630	606	8,515	9,286	8,190	7,024
S. Atlantic.....	12,858	12,370	12,085	11,386	250,967	247,391	237,469	179,512
Ohio.....	4,075	3,900	3,960	3,916	174,410	150,540	144,540	157,513
Indiana.....	4,947	4,850	4,800	4,901	199,364	174,600	188,640	195,496
Illinois.....	10,658	10,150	10,250	10,046	426,320	334,950	400,775	390,219
Michigan.....	1,625	1,690	1,670	1,590	55,250	55,770	54,108	52,907
Wisconsin.....	1,632	1,600	1,520	1,458	58,262	58,080	49,400	49,163
N. C. E. Miss. R....	22,937	22,190	22,200	21,911	913,606	773,940	837,463	845,298
Minnesota.....	2,266	2,200	2,040	2,004	78,177	74,140	66,708	67,897
Iowa.....	10,047	9,850	9,470	9,229	432,021	305,350	343,761	341,750
Missouri.....	7,622	7,400	7,500	7,114	243,904	192,400	247,500	191,427
North Dakota.....	328	290	210	185	8,758	7,250	2,940	4,941
South Dakota.....	2,495	2,310	2,100	2,038	76,347	50,820	52,500	55,559
Nebraska.....	7,609	7,425	7,425	7,266	182,616	155,925	191,565	180,133
Kansas.....	7,575	8,700	8,950	8,109	174,225	126,150	170,050	154,652
N. C. W. Miss. R....	37,942	38,175	37,695	35,945	1,196,048	912,035	1,075,024	996,359
Kentucky.....	3,600	3,600	3,500	3,436	109,440	93,600	101,500	83,348
Tennessee.....	3,332	3,400	3,400	3,146	88,298	91,120	88,060	67,682
Alabama.....	3,150	3,000	2,850	2,573	54,180	54,000	51,300	30,696
Mississippi.....	3,106	2,850	2,590	2,173	56,840	54,150	53,085	28,429
Louisiana.....	1,805	1,800	1,782	1,591	32,490	33,300	42,055	26,010
Texas.....	7,300	7,300	6,800	5,130	153,300	69,350	140,080	75,499
Oklahoma.....	5,448	5,675	5,735	5,914	101,878	36,838	91,760	94,283
Arkansas.....	2,475	2,390	2,390	2,277	50,490	49,712	57,360	37,610
S. Central.....	30,216	30,015	29,047	26,240	646,916	482,120	625,210	443,557
Montana.....	24	20	16	10	612	530	368	274
Wyoming.....	16	13	11	9	368	195	110	176
Colorado.....	420	373	346	327	8,736	5,222	6,885	4,903
New Mexico.....	93	94	89	86	2,083	2,322	2,047	1,165
Arizona.....	16	15	15	16	528	495	488	299
Utah.....	9	8	7	7	270	280	212	170
Nevada.....	1	1	1	1	30	30	30	21
Idaho.....	12	11	10	9	394	330	320	318
Washington.....	31	30	28	26	846	855	784	563
Oregon.....	20	20	18	17	630	570	459	452
California.....	52	51	50	52	1,924	1,836	1,875	1,274
Far Western.....	694	636	591	560	16,421	12,665	13,578	9,915
United States.....	107,083	105,825	104,035	98,383	3,124,746	2,531,488	2,886,260	2,552,190

STATISTICS OF CORN.

561

TABLE 6.—Total farm value and value per acre of corn, by States, 1909–1912.

State and division.	Value, basis Dec. 1 price (000 omitted).				Value per acre, basis Dec. 1 price.			
	1912	1911	1910	1909	1912	1911	1910	1909
	<i>Dollars.</i>	<i>Dollars.</i>	<i>Dollars.</i>	<i>Dollars.</i>	<i>Dollars.</i>	<i>Dollars.</i>	<i>Dollars.</i>	<i>Dollars.</i>
Maine.....	480	713	555	519	30.00	39.60	32.66	34.16
New Hampshire.....	794	849	698	696	34.50	36.90	31.74	35.11
Vermont.....	1,296	1,509	1,249	1,252	28.80	32.80	28.88	29.20
Massachusetts.....	1,629	1,716	1,434	1,644	34.65	36.52	31.85	39.37
Rhode Island.....	401	470	332	386	36.52	42.75	33.20	39.87
Connecticut.....	2,310	2,375	2,062	1,898	38.50	40.26	36.18	39.00
New York.....	13,834	15,712	12,668	13,406	27.02	29.64	24.13	26.20
New Jersey.....	7,054	7,055	5,767	7,101	25.84	26.13	21.60	23.77
Pennsylvania.....	38,797	43,423	34,592	29,046	26.78	30.26	24.19	21.07
N. Atlantic.....	66,595	73,822	59,357	55,948	27.34	30.27	24.56	23.90
Delaware.....	3,381	4,041	3,191	2,807	17.34	20.74	16.54	14.85
Maryland.....	13,450	15,407	12,824	11,651	20.08	23.00	19.43	18.00
Virginia.....	33,739	34,690	32,487	28,338	17.04	17.52	16.58	15.24
West Virginia.....	15,928	13,991	12,376	12,668	21.97	19.79	17.68	18.72
North Carolina.....	42,418	40,738	37,460	28,954	15.11	15.09	14.14	11.82
South Carolina.....	29,136	29,646	25,896	18,785	15.22	16.56	15.17	11.97
Georgia.....	45,864	49,030	40,546	33,862	11.73	13.28	11.31	9.98
Florida.....	6,727	7,429	6,962	5,830	10.27	11.63	11.05	9.38
S. Atlantic.....	190,613	194,975	171,742	142,895	14.83	15.76	14.21	12.55
Ohio.....	78,484	87,313	66,488	88,207	19.26	22.39	16.79	22.51
Indiana.....	83,733	94,284	75,456	97,748	16.93	19.44	15.72	19.95
Illinois.....	174,791	184,222	152,294	202,914	16.40	18.15	14.86	20.18
Michigan.....	31,492	36,250	28,677	32,273	19.38	21.45	17.17	20.31
Wisconsin.....	29,714	34,848	25,688	29,498	18.21	21.78	16.20	20.22
N. C. E. Miss. R.....	398,214	436,917	348,603	450,640	17.36	19.69	15.70	20.57
Minnesota.....	28,925	39,294	30,010	33,270	12.76	17.86	14.72	16.56
Iowa.....	151,207	161,836	123,751	167,458	15.05	16.43	13.07	18.13
Missouri.....	112,196	115,440	108,900	112,942	14.72	15.60	11.52	15.87
North Dakota.....	3,766	4,350	1,705	2,718	11.48	15.00	8.12	14.68
South Dakota.....	28,248	26,935	21,000	27,779	11.32	11.66	10.00	13.65
Nebraska.....	67,563	85,759	68,963	90,066	8.88	11.55	9.29	12.40
Kansas.....	69,660	79,474	76,522	83,512	9.20	9.14	8.55	10.31
N. C. W. Miss. R.....	461,600	513,088	430,863	517,745	12.17	13.44	11.43	14.40
Kentucky.....	60,192	58,968	53,795	51,676	16.72	16.38	15.37	15.07
Tennessee.....	53,862	55,583	49,314	47,378	16.16	16.35	14.50	15.05
Alabama.....	42,802	42,120	36,423	26,091	13.59	14.04	12.78	10.12
Mississippi.....	40,356	38,988	33,450	23,027	12.99	13.68	12.92	10.61
Louisiana.....	22,093	23,310	23,130	17,947	12.24	12.95	12.98	11.25
Texas.....	98,112	55,480	88,250	57,379	13.44	7.60	12.98	11.17
Oklahoma.....	41,770	25,822	46,798	51,856	7.67	4.55	8.16	8.74
Arkansas.....	33,828	35,793	33,269	27,079	13.67	14.98	13.92	11.88
S. Central.....	393,015	336,064	364,429	302,433	13.01	11.20	12.55	11.53
Montana.....	428	424	350	236	17.85	21.20	21.85	24.77
Wyoming.....	236	148	73	138	14.72	11.40	6.60	14.90
Colorado.....	4,368	4,073	4,131	3,432	10.40	10.92	11.94	10.50
New Mexico.....	1,562	1,950	1,842	1,048	16.80	20.75	20.70	12.15
Arizona.....	528	480	537	299	33.00	32.01	35.75	19.10
Utah.....	202	227	178	148	22.50	28.35	25.45	19.40
Nevada.....	29	27	30	18	29.40	27.45	30.00	25.95
Idaho.....	276	280	227	239	22.96	25.50	22.00	18.66
Washington.....	651	675	588	484	21.02	22.52	21.00	18.66
Oregon.....	472	456	367	361	23.02	22.80	20.40	20.88
California.....	1,635	1,652	1,500	1,159	31.45	32.40	30.00	22.30
Far Western.....	10,387	10,392	9,823	7,562	14.97	16.34	16.62	13.50
United States.....	1,520,454	1,565,258	1,384,817	1,477,223	14.20	14.79	13.31	15.02

TABLE 7.—Yield per acre, and price per bushel of corn, by States.

State and division.	Yield per acre.							Farm price per bushel.											
	Ten-year averages.				1910	1911	1912	Ten-year averages for Dec. 1.				Dec. 1, 1910	Dec. 1, 1911	Quarterly, 1912.					
	1870-1879	1880-1889	1890-1899	1900-1909				1870-1879	1880-1889	1890-1899	1900-1909			Mar. 1	June 1	Sept. 1	Dec. 1		
Bu.	Bu.	Bu.	Bu.	Bu.	Bu.	Bu.	Cts.	Cts.	Cts.	Cts.	Cts.	Cts.	Cts.	Cts.	Cts.	Cts.	Cts.		
Me.	31.0	32.2	37.1	35.4	46.0	44.0	40.0	53	75	60	72	71	90	85	92	89	75		
N. H.	37.8	32.7	37.2	33.1	46.0	45.0	46.0	82	75	58	70	69	82	79	83	82	75		
Vt.	37.3	32.6	38.2	34.5	43.0	41.0	40.0	80	71	56	68	66	80	76	85	84	72		
Mass.	34.7	31.6	37.6	36.1	45.5	44.0	45.0	79	74	58	71	70	83	82	90	88	77		
R. I.	29.6	30.1	31.7	33.0	40.0	45.0	41.5	83	77	63	79	83	95	96	110	110	88		
Conn.	29.8	30.1	34.9	36.8	53.2	48.5	50.0	84	71	58	70	68	83	80	88	90	77		
N. Y.	33.0	29.8	31.4	31.0	38.3	38.5	38.6	66	62	52	66	63	77	78	87	83	70		
N. J.	36.3	30.5	33.0	34.1	36.0	36.5	38.0	59	59	49	59	60	71	76	91	90	68		
Pa.	35.7	31.0	32.6	34.4	41.0	44.5	42.5	57	56	46	59	59	68	74	88	86	63		
N. Atlantic.	34.8	30.7	32.7	33.0	40.3	42.4	41.4	61.8	59.6	49.1	61.7	60.9	71.4	75.5	88.1	85.9	66.1		
Del.	23.4	19.3	22.5	29.1	31.8	34.0	34.0	51	47	39	50	52	61	70	88	87	51		
Md.	25.2	24.2	27.0	32.9	33.5	36.5	36.5	54	49	41	52	58	63	70	88	85	55		
Va.	20.1	16.8	19.1	22.7	25.5	24.0	24.0	51	51	43	59	65	73	81	98	96	71		
W. Va.	28.3	23.4	24.4	27.5	26.0	25.7	33.8	49	51	48	63	68	77	83	96	92	65		
N. C.	14.7	12.2	13.0	14.8	18.6	18.4	18.2	57	59	47	68	76	82	88	107	100	83		
S. C.	9.4	9.4	9.9	11.6	18.5	18.2	17.9	80	68	56	76	82	91	94	111	107	85		
Ge.	11.2	10.4	11.1	11.5	14.5	16.0	13.8	73	66	54	73	78	83	87	107	104	85		
Fla.	10.2	9.6	9.7	10.2	13.0	14.6	13.0	91	76	61	74	85	80	92	104	93	79		
S. Atlantic.	15.0	13.8	14.5	16.1	19.6	20.0	19.5	61.0	57.5	48.1	65.7	72.3	78.8	84.7	102.5	93.5	76.0		
Ohio	36.1	30.8	31.4	35.6	36.5	38.6	42.8	39	43	35	48	46	58	64	79	77	45		
Ind.	32.6	28.9	31.3	34.7	39.3	36.0	40.3	34	39	31	43	40	54	62	77	75	42		
Ill.	30.3	26.8	31.7	34.5	39.3	33.0	40.0	30	36	30	43	38	55	60	77	72	41		
Mich.	33.1	28.9	29.0	32.7	32.4	33.0	34.0	46	46	40	51	53	65	64	77	75	57		
Wis.	33.1	27.3	30.6	33.2	32.5	36.3	35.7	40	41	34	48	52	60	60	67	69	51		
N. C. E. M. R.	32.1	28.1	31.3	34.3	37.7	34.9	39.8	34.0	39.0	32.0	44.5	41.6	56.5	61.5	76.6	73.6	43.6		
Minn.	32.5	29.9	28.1	29.4	32.7	33.7	34.5	37	37	31	41	45	53	50	58	59	37		
Iowa	34.5	30.6	30.9	32.3	36.3	31.0	43.0	25	30	27	39	36	53	56	70	67	35		
Mo.	30.2	27.4	27.4	28.6	33.0	26.0	32.0	32	35	31	45	44	60	65	82	77	46		
N. Dak.	25.3	20.8	20.8	23.4	14.0	25.0	26.7	36	36	46	58	60	66	71	66	43			
S. Dak.	27.4	20.1	20.1	27.4	25.0	22.0	30.6	36	30	39	40	53	54	69	61	37			
Nebr.	34.5	32.7	24.5	27.4	25.8	21.0	24.0	26	25	27	38	36	55	56	73	68	37		
Kans.	34.3	28.6	21.3	22.4	19.0	14.5	23.0	32	30	30	42	45	63	65	79	73	40		
N. C. W. M. R.	33.1	29.4	26.2	27.9	28.5	23.9	31.5	27.8	30.4	28.3	40.4	40.1	56.3	58.6	73.3	69.1	38.6		
Ky.	29.7	23.8	25.7	26.7	29.0	26.0	30.4	38	44	37	51	53	63	75	93	89	55		
Tenn.	24.2	20.5	22.0	23.0	25.9	26.8	26.5	43	45	38	55	56	61	71	96	92	61		
Ala.	13.9	12.6	12.8	13.5	18.0	18.0	17.2	70	62	51	69	71	78	83	103	101	79		
Miss.	15.4	14.3	15.0	15.2	20.5	19.0	18.3	72	61	49	67	63	72	78	103	92	71		
La.	17.2	16.0	16.3	17.5	23.6	18.5	18.0	78	62	51	64	55	70	74	97	80	68		
Tex.	21.7	18.1	19.0	19.0	20.6	9.5	21.0	68	56	46	59	63	80	90	103	74	64		
Okl.	24.4	19.8	24.2	21.6	6.5	18.7					44	51	70	74	84	72	41		
Ark.	24.4	19.8	18.2	18.7	24.0	20.8	20.4	59	53	43	58	58	72	81	99	90	67		
S. Central.	21.2	18.5	19.0	20.1	21.5	16.1	21.4	53.9	51.4	42.8	55.5	58.3	69.7	78.1	97.4	87.3	60.8		
Mont.	26.4	25.0	23.2	23.0	26.5	25.5		79	67	73	95	80	106	99	125	70			
Wyo.	21.2	28.0	10.0	15.0	23.0				59	66	66	76				64			
Colo.	29.2	26.1	18.9	21.2	19.9	14.0	20.8	90	72	47	59	60	78	74	83	80	50		
N. Mex.	19.9	21.4	26.4	23.0	24.7	22.4			76	65	76	90	84	114	110	73	75		
Ariz.	20.9	20.0	27.1	32.5	33.0	33.0			80	76	94	110	97	95	106	114	100		
Utah	21.0	21.2	26.9	30.3	35.0	30.0			71	58	74	84	81	84	85	100	75		
Nev.	30.9	24.4			30.0	30.0		135	74			100	90			98			
Idaho	23.3	23.9	28.5	32.0	30.0	32.8			80	65	65	71	85	89	96	90	70		
Wash.	24.8	18.0	23.8	28.0	28.5	27.3			74	55	65	75	79	77	105	76	77		
Oreg.	29.3	23.8	24.0	25.8	25.5	31.5			90	72	58	66	80	90	100	85	75		
Cal.	34.8	28.0	30.5	31.4	37.5	36.0	37.0	96	70	58	76	80	90	89	100	99	85		
Far Western.	31.5	26.2	22.6	25.1	23.0	19.9	23.7	92.0	72.2	54.0	68.6	72.3	82.1	87.7	94.9	85.8	63.3		
United States.	27.1	24.1	24.1	25.8	27.7	23.9	29.2	40.5	40.6	34.5	47.6	48.0	61.8	66.6	82.5	77.6	48.7		

<sup>1</sup> The Territories.

TABLE 8.—Wholesale price of corn per bushel, 1899–1912.

Date.	New York.		Baltimore.		Cincinnati.		Chicago.		Detroit.		St. Louis.		San Francisco.	
	No. 2 mixed.		Mixed. <sup>1</sup>		No. 2.		Contract. <sup>2</sup>		No. 3. <sup>3</sup>		No. 2.		No. 1 white (per 100 lbs.).	
	Low.	High.	Low.	High.	Low.	High.	Low.	High.	Low.	High.	Low.	High.	Low.	High.
1899.....	Cts. 36½	Cts. 45½	Cts. 34½	Cts. 43	Cts. 31½	Cts. 38	Cts. 30	Cts. 38½	Cts. 32	Cts. 38	Cts. 29½	Cts. 36½	Dolls. 1.05	Dolls. 1.17½
1900.....	39½	52½	36½	48½	32½	47	30½	49½	32½	45	30½	43	1.00	1.30
1901.....	45½	72½	41½	68	38	71½	36	67½	37	70½	35	70	1.10	1.75
1902.....	57	78	43	77	44	69	43½	88	57	70½	40½	69½	1.30	1.65
1903.....	49½	68½	46½	61	40	54½	41	53	40	56½	39	55	1.17½	1.57½
1904.....	47½	69	49½	58	45½	58½	42	59½	42	60	42½	57	1.25	1.55
1905.....	50½	63½	42	65	44½	59½	42	64½	44½	59	41½	58½	1.25	1.55
1906.....	47	61½	45½	58	42	55½	39	54½	43	55	39½	54½	.....	.....
1907.....	49½	77	47	74½	43	71	39½	66½	43	69½	39	66	1.25	1.60
1908.....	60½	90½	59½	83½	54½	83½	56½	82	53½	83	54½	81½	1.60	1.90
1909.														
January.....	66½	68½	64½	67	61	62½	58½	60½	60½	62½	58	62	1.72½	1.75
February.....	68½	73	67½	71½	61	61	61	65½	62½	67½	61	65	.....	.....
March.....	72½	74½	70½	73½	66½	69	64	67½	66½	68½	64½	67½	.....	.....
April.....	74½	80	72½	79	68½	76½	66½	72½	68½	75	66	74½	1.90	1.95
May.....	80	82	78½	82	76	78	72½	76	75	79	73	77	1.85	1.95
June.....	79	83	76½	81½	74	77	71½	77	75½	77½	71½	75½	.....	.....
July.....	77	80	74	77½	72	75½	68	74½	73	75½	67½	74½	.....	.....
August.....	79	79	72	76	69	74	66½	70	71½	74	64	69	1.80	1.85
September.....	73	76	74	74	65½	72	63	69½	66	74	62½	69½	.....	.....
October.....	68½	72	64½	68½	61	66	59	62	62½	65	59	63½	.....	.....
November.....	69½	73	64½	69	57	63½	61½	64½	60½	64	58	63	1.80	1.85
December.....	66	69½	63½	67½	57	64	62½	66	59	63½	58	63½	1.75	1.85
Year.....	66	83	63½	82	57	78	58½	77	59	79	58	77	1.72½	1.95
1910.														
January.....	69	74½	67	70½	63½	69½	62½	68	63½	68½	63	68	1.75	1.85
February.....	68½	73½	66½	69½	61½	66	63	66	63	66	63	65	1.80	1.85
March.....	64½	68½	62½	67	59	63½	60	65½	59½	63	59	63	1.75	1.80
April.....	62½	65	60½	64½	58	63½	56½	61	58½	61½	59	64½	1.62½	1.75
May.....	65½	69	61½	64½	60	66	56	63	58	64	59	66½	1.65	1.75
June.....	65	69	61	63	60½	63	57½	60½	60	63½	58½	62	1.60	1.67½
July.....	67	73	62	70	62	67½	59½	66½	62½	64	59	67½	1.62½	1.72½
August.....	68	71	66	70½	61½	67½	58½	67½	62	67½	59	68	1.70	1.72½
September.....	60	65½	58	65½	53½	61½	50	60	53	61	51½	59	1.60	1.70
October.....	55½	61	54	58	49½	54½	47½	52½	51	53	48	54	1.62½	1.65
November.....	52½	59	52	53½	50½	55½	47½	52	51½	53½	45	50½	1.40	1.45
December.....	51½	57	50	53½	46	54	45½	50	46½	54	44	50½	1.40	1.45
Year.....	52	74	50	70½	46	69½	45½	68	46½	68½	44	68	1.40	1.85
1911.														
January.....	Nominal.	50½	51½	45½	49	45½	47½	47	48	44	47	47	1.31½	1.33½
February.....	53½	55½	49½	51½	46½	48½	45½	48	46	47	43½	45½	1.31½	1.36½
March.....	Nominal.	48½	50½	46	49½	45½	48	45½	48	44	47	47	1.31½	1.36½
April.....	58½	61½	49½	57	47	56½	46	53½	46½	54½	45	52½	1.40	1.42½
May.....	59½	62½	56½	61	53½	57	52½	55½	54½	56½	51½	55	1.42½	1.48½
June.....	60½	65½	58½	63½	55	60	53½	59½	55	59	53½	60½	1.47½	1.54½
July.....	66	71½	63½	69	61½	70	59½	67	59½	68½	61	68½	1.65	1.67½
August.....	70	73½	67	70½	65	68½	62½	65½	64½	67	62½	66	1.60	1.67½
September.....	73½	76	71½	73½	65½	71½	65½	69	66	70	63½	69	1.63½	1.65
October.....	76½	81½	73½	79	71	77½	69½	75	70½	76	68	74	1.63½	1.80
November.....	78½	79½	69½	72½	65	77	69	76	65	76	71	77	1.75	1.80
December.....	Nominal.	66½	70½	61	70	68	71	61	65	65	62½	74	1.55	1.80
Year.....	53½	81½	48½	79	45½	77½	45½	76	45½	76	43½	77	1.31½	1.80
1912.														
January.....	67½	73	67	71½	65	69	63½	70	62½	66½	63	68½	1.55	1.64
February.....	71½	74	69	74	64	69	63½	66½	65	67	67½	68½	1.62	1.64
March.....	73½	78½	69½	74½	68	80	66½	74	67	73	68½	75½	1.62	1.64
April.....	79½	86½	75½	84½	78	87	74	81½	73½	82	76	83½	1.62	1.97½
May.....	83	87½	78	85	79	85	76	85	77½	83½	79	85	1.90	1.97
June.....	78½	84	74½	77	75	83	72½	76	75½	78	72½	79	1.87	1.92
July.....	76½	84	75	78½	73	80	69½	75	72	77	69½	77½	1.80	1.90
August.....	81½	83	76½	87	75	83	73½	83	75½	81	71½	80	1.80	1.90
September.....	.....	.....	73	86	69	84	68½	79	70½	81	68	79½	1.76	1.95
October.....	.....	.....	66	75	64	72	58½	69	62½	69½	62	70	1.50	1.78
November.....	.....	.....	52½	66	47	64	50	58½	49	63	45½	62	1.50	1.65
December.....	54½	58	52	54½	48	51	47½	54	48	49½	45	48½	1.60	1.70
Year.....	54½	87½	52	87	47	87	47½	83	48	83½	45	85	1.50	1.97½

<sup>1</sup> No. 2 grade, 1899 and 1900.

<sup>2</sup> No. 2 grade, 1899 to 1908.

<sup>3</sup> No. 2 grade, 1899 to 1904.



TABLE 9.—Condition of corn crop, United States, on first of months named, 1892–1912.

Year.	July.	Aug.	Sept.	Oct.	Year.	July.	Aug.	Sept.	Oct.	Year.	July.	Aug.	Sept.	Oct.
1892....	<i>P. ct.</i>	<i>P. ct.</i>	<i>P. ct.</i>	<i>P. ct.</i>	1899....	<i>P. ct.</i>	<i>P. ct.</i>	<i>P. ct.</i>	<i>P. ct.</i>	1906....	<i>P. ct.</i>	<i>P. ct.</i>	<i>P. ct.</i>	<i>P. ct.</i>
1893....	81.1	82.5	79.6	79.8	1900....	86.5	89.9	85.2	82.7	1907....	87.5	88.0	90.2	90.1
1894....	93.2	87.0	76.7	75.1	1901....	89.5	87.5	80.6	78.2	1908....	80.2	82.8	80.2	78.0
1895....	95.0	69.1	63.4	64.2	1902....	81.3	54.0	51.7	52.1	1909....	82.8	82.5	79.4	77.8
1896....	99.3	102.5	96.4	95.5	1903....	87.5	86.5	84.3	79.6	1910....	89.3	84.4	74.6	73.8
1897....	92.4	96.0	91.0	90.5	1904....	79.4	78.7	80.1	80.8	1911....	85.4	79.3	78.2	80.3
1898....	82.9	84.2	79.3	77.1	1905....	86.4	87.3	84.6	83.9	1912....	80.1	69.6	70.3	70.4
1899....	90.5	87.0	84.1	82.0							81.5	80.0	82.1	82.2

TABLE 10.—Farm price of corn per bushel on first of each month, 1911 and 1912.

Month	United States.		North Atlantic States.		South Atlantic States.		N. Central States east of Miss. R.		N. Central States west of Miss. R.		South Central States.		Far Western States.	
	1912	1911	1912	1911	1912	1911	1912	1911	1912	1911	1912	1911	1912	1911
	<i>Cts.</i>	<i>Cts.</i>	<i>Cts.</i>	<i>Cts.</i>	<i>Cts.</i>	<i>Cts.</i>	<i>Cts.</i>	<i>Cts.</i>	<i>Cts.</i>	<i>Cts.</i>	<i>Cts.</i>	<i>Cts.</i>	<i>Cts.</i>	<i>Cts.</i>
January.....	62.2	48.2	73.3	59.6	80.0	71.7	56.5	41.5	55.3	38.3	72.5	59.9	82.6	73.1
February.....	64.6	49.0	73.3	59.3	82.3	73.1	59.3	42.6	57.8	39.4	74.5	59.9	79.2	72.3
March.....	66.6	48.9	75.5	59.3	84.7	72.4	61.5	41.8	58.6	39.3	78.1	61.0	87.7	71.7
April.....	71.1	49.7	78.3	58.4	88.5	73.3	66.0	42.4	63.4	40.2	82.8	62.1	88.4	71.9
May.....	79.4	51.8	83.9	59.2	97.7	74.4	74.5	45.6	71.4	42.4	91.9	63.1	85.2	80.2
June.....	82.5	55.1	88.1	64.2	102.5	78.1	76.6	49.5	73.3	45.7	97.4	65.4	94.9	80.9
July.....	81.1	60.0	88.6	65.4	102.0	80.7	75.4	53.1	71.3	51.9	96.1	69.9	100.0	89.2
August.....	79.3	65.8	86.0	71.2	101.2	85.5	72.6	59.3	69.8	59.3	95.0	74.7	91.9	89.4
September.....	77.6	65.9	85.9	72.8	98.5	87.4	73.6	61.4	69.1	57.5	87.3	74.4	85.8	86.7
October.....	70.2	65.7	79.8	73.3	92.8	84.1	67.9	62.2	62.1	58.1	75.7	72.8	66.3	85.0
November.....	58.4	64.7	72.5	71.2	82.5	79.7	53.2	59.7	50.1	58.9	66.6	72.3	83.6	79.2
December.....	48.7	61.8	66.1	71.4	76.0	78.8	43.6	56.5	38.6	56.3	60.8	69.7	63.3	82.1

TABLE 11.—International trade in corn, including corn meal, calendar years 1907–1911.

[The item *maicena* or *maizena* is included as "Corn and corn meal."]

GENERAL NOTE.—Substantially the international trade of the world. It should not be expected that the world export and import totals for any year will agree. Among sources of disagreement are these: (1) Different periods of time covered in the "year" of the various countries; (2) imports received in year subsequent to year of export; (3) want of uniformity in classification of goods among countries; (4) different practices and varying degrees of failure in recording countries of origin and ultimate destination; (5) different practices of recording reexported goods; (6) opposite methods of treating free ports; (7) clerical errors, which, it may be assumed, are not infrequent.

The exports given are domestic exports, and the imports given are imports for consumption as far as it is feasible and consistent so to express the facts. While there are some inevitable omissions, on the other hand, there are some duplications because of reshipments that do not appear as such in official reports. For the United Kingdom import figures refer to imports for consumption, when available, otherwise total imports less exports of "foreign and colonial merchandise." Figures for the United States include Alaska, Porto Rico, and Hawaii.

## EXPORTS.

Country.	1907	1908	1909	1910	1911
Argentina.....	<i>Bushels.</i> 50,262,203	<i>Bushels.</i> 67,390,055	<i>Bushels.</i> 89,499,359	<i>Bushels.</i> 104,727,358	<i>Bushels.</i> 4,928,265
Austria-Hungary.....	120,143	381,817	48,218	1,069,219	156,216
Belgium.....	7,644,770	6,134,858	7,088,377	7,581,989	8,846,390
British South Africa.....	1,666,594	1,685,637	5,468,724	6,517,485	3,892,164
Bulgaria.....	10,225,350	4,393,836	5,009,230	4,822,817	13,980,152
Netherlands.....	8,215,849	6,957,455	7,308,873	5,101,056	5,939,283
Roumania.....	54,720,648	28,960,051	29,091,585	23,419,157	123,419,157
Russia.....	38,636,220	23,545,045	26,535,758	17,685,570	52,759,472
Servia.....	4,046,351	1,934,464	3,767,180	6,694,817	4,627,040
United States.....	86,524,012	39,013,273	38,114,098	44,072,299	63,533,483
Uruguay <sup>2</sup> .....	88,658	19,539	775,566	192,359	1,192,359
Other countries.....	3,547,000	7,769,000	8,041,000	5,659,000	35,465,000
Total.....	265,697,798	188,185,030	220,747,968	227,543,036	187,738,981

<sup>1</sup> Year preceding.

<sup>2</sup> Year beginning July 1.

<sup>3</sup> Preliminary.

TABLE 11.—*International trade in corn, including corn meal, calendar years 1907-1911—Continued.*

IMPORTS.

Country.	1907	1908	1909	1910	1911
	<i>Bushels.</i>	<i>Bushels.</i>	<i>Bushels.</i>	<i>Bushels.</i>	<i>Bushels.</i>
Austria-Hungary.....	4,002,672	3,106,632	4,050,645	2,494,032	7,885,811
Belgium.....	23,505,598	19,157,905	22,099,548	25,035,630	24,814,463
British South Africa.....	35,422	132,569	155,390	69,463	29,450
Canada.....	16,187,579	6,812,833	7,563,688	10,767,402	16,440,351
Cuba.....	3,153,495	1,837,974	2,249,996	3,002,432	<sup>1</sup> 3,002,432
Denmark.....	17,854,964	10,445,451	9,151,749	7,217,422	11,085,021
Egypt.....	196,538	845,197	748,865	83,038	227,370
France.....	16,850,448	9,629,882	11,213,413	15,355,323	<sup>2</sup> 19,742,322
Germany.....	49,292,537	26,372,031	27,833,917	22,562,742	29,266,872
Italy.....	2,815,093	2,973,462	8,459,986	15,756,325	15,117,655
Mexico.....	1,554,129	179,155	1,167,733	8,907,181	<sup>1</sup> 8,907,181
Netherlands.....	29,191,904	25,261,147	22,914,269	21,511,620	25,743,031
Norway.....	1,937,905	809,832	965,347	788,600	1,019,181
Portugal.....	577,720	2,015,368	2,367,800	518,042	<sup>1</sup> 518,042
Russia.....	550,841	355,769	212,817	180,924	388,870
Spain.....	4,552,133	3,320,007	6,411,009	7,526,303	5,684,772
Sweden.....	2,330,585	488,074	272,284	277,160	459,755
Switzerland.....	2,867,736	2,480,140	3,143,216	3,605,403	4,059,590
United Kingdom.....	106,708,046	68,186,272	78,057,366	73,486,852	77,449,105
Other countries.....	3,163,000	2,959,000	3,493,000	1,771,000	<sup>2</sup> 2,152,000
Total.....	285,328,345	187,318,700	212,532,338	220,916,894	253,953,274

<sup>1</sup> Year preceding.

<sup>2</sup> Preliminary.

WHEAT.

TABLE 12.—*Wheat area of countries named, 1908-1912.*

Country.	1908	1909	1910	1911	1912
NORTH AMERICA.					
	<i>Aeres.</i>	<i>Aeres.</i>	<i>Aeres.</i>	<i>Aeres.</i>	<i>Aeres.</i>
United States.....	47,557,000	44,261,000	45,681,000	49,543,000	45,814,000
Canada:					
New Brunswick.....	20,200	19,600	19,500	13,200	12,400
Ontario.....	812,400	705,800	729,500	941,300	671,000
Manitoba.....	2,957,000	2,893,000	3,014,400	2,979,700	2,653,100
Saskatchewan.....	2,396,000	3,685,000	4,845,000	4,704,700	4,891,500
Alberta.....	271,000	385,000	533,000	1,616,900	1,417,200
Other.....	153,700	147,000	150,400	121,400	113,200
Total Canada.....	6,610,300	7,750,400	9,294,800	10,377,200	9,758,400
Mexico.....	( <sup>1</sup> )	( <sup>1</sup> )	2,627,600	( <sup>1</sup> )	( <sup>1</sup> )
SOUTH AMERICA.					
Argentina.....	14,232,900	14,981,900	14,422,100	15,451,600	17,042,500
Chile.....	1,137,700	1,100,100	839,700	967,800	( <sup>1</sup> )
Uruguay.....	611,800	683,900	( <sup>1</sup> )	636,600	798,700
EUROPE.					
Austria-Hungary:					
Austria.....	2,959,600	2,942,100	2,998,800	3,002,500	3,114,200
Hungary proper.....	8,715,000	8,036,500	8,584,200	8,352,600	8,748,400
Croatia-Slavonia.....	758,800	762,200	804,400	811,000	834,400
Bosnia-Herzegovina.....	272,100	205,100	247,100	192,800	( <sup>1</sup> )
Total Austria-Hungary.....	12,705,500	11,945,900	12,634,500	12,358,900	.....
Belgium.....	377,600	389,800	( <sup>1</sup> )	( <sup>1</sup> )	( <sup>1</sup> )
Bulgaria.....	2,422,700	2,570,200	2,690,200	2,763,600	( <sup>1</sup> )
Denmark.....	<sup>2</sup> 100,100	( <sup>1</sup> )	( <sup>1</sup> )	( <sup>1</sup> )	( <sup>1</sup> )
Finland.....	( <sup>1</sup> )	( <sup>1</sup> )	( <sup>1</sup> )	( <sup>1</sup> )	( <sup>1</sup> )
France.....	16,220,600	16,299,300	16,198,300	15,896,800	16,198,600
Germany.....	4,656,800	4,525,300	4,800,900	4,878,200	4,758,500
Greece.....	( <sup>1</sup> )	( <sup>1</sup> )	( <sup>1</sup> )	( <sup>1</sup> )	( <sup>1</sup> )
Italy.....	12,621,100	11,635,900	11,758,500	11,741,200	11,750,600
Montenegro.....	( <sup>1</sup> )	( <sup>1</sup> )	( <sup>1</sup> )	( <sup>1</sup> )	( <sup>1</sup> )
Netherlands.....	139,000	126,700	135,300	142,200	142,500
Norway.....	<sup>2</sup> 12,400	( <sup>1</sup> )	( <sup>1</sup> )	( <sup>1</sup> )	( <sup>1</sup> )
Portugal.....	( <sup>1</sup> )	( <sup>1</sup> )	( <sup>1</sup> )	1,211,200	( <sup>1</sup> )
Roumania.....	4,452,000	4,173,600	4,814,000	4,769,400	5,113,500

<sup>1</sup> No official statistics of area.

<sup>2</sup> Area in 1907.

TABLE 12.—Wheat area of countries named, 1908-1912—Continued.

Country.	1908	1909	1910	1911	1912
EUROPE—continued.					
Russia:	<i>Acres.</i>	<i>Acres.</i>	<i>Acres.</i>	<i>Acres.</i>	<i>Acres.</i>
Russia proper.....	46,607,700	47,406,400	51,887,800	52,556,800	.....
Poland.....	1,218,700	1,227,200	1,255,500	1,254,800	.....
Northern Caucasia.....	7,958,600	8,376,800	9,453,200	9,907,600	.....
Total Russia (European).....	55,785,000	57,010,400	62,596,500	63,719,200	1 71,300,200
Servia.....	931,300	934,200	952,800	955,000	(2)
Spain.....	9,283,000	9,347,200	9,413,200	9,705,800	9,624,700
Sweden.....	224,900	236,600	241,000	250,800	(2)
Switzerland.....	(2)	(2)	(2)	(2)	(2)
Turkey (European).....	1,061,200	(2)	(2)	(2)	(2)
United Kingdom:					
Great Britain—					
England.....	1,548,700	1,734,200	1,716,600	1,804,000	1,821,900
Scotland.....	43,400	49,700	52,800	63,500	62,400
Wales.....	34,600	39,600	39,400	38,500	41,400
Ireland.....	36,700	43,600	47,600	45,100	44,900
Total United Kingdom.....	1,663,400	1,867,100	1,856,400	1,951,100	1,970,600
ASIA.					
British India, including such native States as report.....	22,911,300	26,235,900	28,106,500	30,564,800	30,517,800
Cyprus.....	(2)	(2)	(2)	(2)	(2)
Japanese Empire:					
Japan.....	1,101,800	1,106,200	1,165,200	1,223,400	1,216,400
Formosa.....	(2)	(2)	(2)	(2)	(2)
Persia.....	(2)	(2)	(2)	(2)	(2)
Russia:					
Central Asia.....	2,155,200	3,322,200	3,236,700	4,214,000	.....
Siberia.....	4,470,700	5,073,100	5,221,600	5,887,900	.....
Transcaucasia.....	7,800	9,000	11,200	10,600	.....
Total Russia (Asiatic).....	6,633,700	8,404,300	8,469,500	10,112,500	(2)
Turkey.....	(2)	(2)	(2)	(2)	(2)
AFRICA.					
Algeria.....	3,597,000	2,814,200	3,426,500	3,304,700	3,614,400
Egypt.....	1,296,700	1,299,300	1,284,900	1,330,700	(2)
Tunis.....	1,084,800	956,300	1,112,000	1,401,100	1,262,700
Union of South Africa.....	(2)	(2)	(2)	(2)	(2)
AUSTRALASIA.					
Australia:					
Queensland.....	82,500	80,900	117,200	106,700	43,000
New South Wales.....	1,390,200	1,394,100	1,990,200	2,128,800	2,380,700
Victoria.....	1,847,100	1,779,900	2,097,200	2,398,100	2,164,000
South Australia.....	1,730,500	1,693,500	1,895,700	2,104,700	2,190,800
Western Australia.....	279,600	285,000	448,900	581,900	612,100
Tasmania.....	30,800	29,100	37,100	52,200	37,200
Total Australia.....	5,360,700	5,262,500	6,586,300	7,372,400	7,427,800
New Zealand.....	193,000	252,400	311,000	322,200	215,500
Total Australasia.....	5,553,700	5,514,900	6,897,300	7,694,600	7,643,300

<sup>1</sup> Includes Asiatic Russia (10 Governments of).

<sup>2</sup> No official statistics of area.

<sup>3</sup> Included in European Russia.

TABLE 13.—Wheat crop of countries named, 1908–1912.

Country.	1908	1909	1910	1911	1912
<b>NORTH AMERICA.</b>					
United States.....	<i>Bushels.</i> 664,602,000	<i>Bushels.</i> 683,350,000	<i>Bushels.</i> 635,121,000	<i>Bushels.</i> 621,348,000	<i>Bushels.</i> 730,267,000
Canada:					
New Brunswick.....	349,000	395,000	371,000	270,000	225,000
Ontario.....	18,057,000	16,262,000	17,805,000	19,252,000	13,638,000
Manitoba.....	50,269,000	52,706,000	41,159,000	60,275,000	58,899,000
Saskatchewan.....	34,742,000	85,197,000	81,139,000	97,665,000	93,849,000
Alberta.....	6,842,000	9,579,000	6,593,000	36,143,000	30,574,000
Other.....	2,175,000	2,605,000	2,923,000	2,313,000	2,051,000
Total Canada.....	112,434,000	166,744,000	149,990,000	215,918,000	199,236,000
Mexico.....	10,000,000	10,000,000	11,976,000	12,000,000	12,000,000
Total.....	787,036,000	860,094,000	797,087,000	849,256,000	941,503,000
<b>SOUTH AMERICA.</b>					
Argentina.....	192,487,000	156,162,000	131,010,000	145,981,000	166,190,000
Chile.....	18,915,000	17,671,000	19,682,000	18,184,000	20,000,000
Uruguay.....	7,430,000	8,595,000	7,750,000	6,009,000	8,757,000
Total.....	218,832,000	182,428,000	158,442,000	170,174,000	194,947,000
<b>EUROPE.</b>					
Austria-Hungary:					
Austria.....	62,129,000	58,477,000	58,213,000	58,865,000	69,712,000
Hungary proper.....	152,204,000	113,352,000	169,700,000	174,888,000	73,328,000
Croatia-Slavonia.....	13,220,000	11,662,000	11,434,000	15,881,000	11,314,000
Bosnia-Herzegovina.....	3,023,000	2,594,000	2,671,000	2,941,000	2,993,000
Total Austria-Hungary.....	230,576,000	186,085,000	242,018,000	252,575,000	257,347,000
Belgium.....	13,393,000	14,603,000	12,449,000	14,616,000	15,000,000
Bulgaria.....	36,496,000	32,071,000	42,247,000	48,000,000	45,000,000
Denmark.....	4,318,000	3,829,000	4,547,000	4,466,000	3,600,000
Finland.....	111,000	134,000	125,000	125,000	130,000
France.....	317,765,000	356,193,000	257,667,000	315,126,000	334,871,000
Germany.....	138,440,000	137,999,000	141,884,000	149,411,000	160,224,000
Greece.....	8,000,000	7,000,000	7,000,000	8,000,000	7,000,000
Italy.....	152,236,000	190,378,000	153,403,000	192,395,000	165,720,000
Montenegro.....	200,000	200,000	200,000	200,000	200,000
Netherlands.....	5,121,000	4,158,000	4,441,000	5,511,000	4,500,000
Norway.....	333,000	313,000	294,000	271,000	332,000
Portugal.....	6,944,000	6,500,000	9,120,000	11,684,000	7,500,000
Roumania.....	54,813,000	56,751,000	110,761,000	93,724,000	88,924,000
Russia:					
Russia proper.....	383,016,000	586,819,000	552,067,000	346,372,000	.....
Poland.....	21,182,000	21,194,000	22,757,000	24,129,000	.....
Northern Caucasia.....	84,964,000	103,465,000	124,589,000	76,537,000	.....
Total Russia (European).....	489,162,000	711,478,000	699,413,000	447,038,000	623,728,000
Servia.....	11,495,000	16,126,000	15,561,000	15,312,000	14,000,000
Spain.....	119,970,000	144,105,000	137,448,000	148,495,000	109,783,000
Sweden.....	6,756,000	6,978,000	7,450,000	7,945,000	7,832,000
Switzerland.....	3,527,000	3,568,000	2,756,000	3,524,000	3,000,000
Turkey (European).....	19,462,000	20,000,000	20,000,000	20,000,000	18,000,000
United Kingdom:					
England.....	51,371,000	60,121,000	53,464,000	60,729,000	54,249,000
Wales.....	966,000	1,147,000	1,122,000	1,118,000	1,124,000
Scotland.....	1,854,000	2,111,000	2,020,000	2,786,000	2,472,000
Ireland.....	1,438,000	1,809,000	1,716,000	1,656,000	1,564,000
Total United Kingdom.....	55,629,000	65,188,000	58,322,000	66,289,000	59,409,000
Total.....	1,674,747,000	1,963,657,000	1,927,106,000	1,804,705,000	1,926,100,000
<b>ASIA.</b>					
British India, including such native States as report.....	228,670,000	285,189,000	359,654,000	374,845,000	366,370,000
Cyprus.....	2,556,000	1,912,000	2,169,000	2,394,000	2,000,000
Japanese Empire:					
Japan.....	22,587,000	22,966,000	24,487,000	25,645,000	26,514,000
Formosa.....	200,000	200,000	200,000	200,000	200,000
Total Japanese Empire.....	22,787,000	23,166,000	24,687,000	25,845,000	25,200,000
Persia.....	16,000,000	16,000,000	16,000,000	16,000,000	16,000,000

TABLE 13.—Wheat crop of countries named, 1908-1912—Continued.

Country.	1908	1909	1910	1911	1912
ASIA—continued.					
Russia:	<i>Bushels.</i>	<i>Bushels.</i>	<i>Bushels.</i>	<i>Bushels.</i>	<i>Bushels.</i>
Central Asia.....	21,416,000	26,429,000	24,009,000	20,579,000	.....
Siberia.....	55,755,000	45,269,000	52,140,000	50,116,000	.....
Transcaucasia.....	66,000	94,000	133,000	102,000	.....
Total Russia (Asiatic).....	77,237,000	71,792,000	76,282,000	70,797,000	103,283,000
Turkey (Asia Minor only).....	35,000,000	35,000,000	35,000,000	35,000,000	35,000,000
Total.....	382,250,000	433,059,000	513,792,000	524,881,000	549,367,000
AFRICA.					
Algeria.....	31,260,000	29,739,000	35,722,000	35,874,000	27,507,000
Egypt.....	30,000,000	30,000,000	32,623,000	38,046,000	32,000,000
Tunis.....	3,674,000	6,430,000	5,512,000	8,635,000	4,225,000
Union of South Africa.....	2,500,000	2,500,000	2,500,000	2,500,000	2,500,000
Total.....	67,434,000	68,669,000	76,357,000	85,055,000	66,232,000
AUSTRALASIA.					
Australia:					
Queensland.....	715,000	1,241,000	1,621,000	1,055,000	294,000
New South Wales.....	9,444,000	15,971,000	29,431,000	28,793,000	25,879,000
Victoria.....	12,482,000	24,081,000	29,687,000	35,910,000	21,550,000
South Australia.....	19,739,000	20,009,000	25,926,000	25,112,000	20,994,000
Western Australia.....	3,018,000	2,538,000	5,779,000	6,083,000	4,496,000
Tasmania.....	665,000	723,000	819,000	1,156,000	681,000
Total Australia.....	46,063,000	64,563,000	93,263,000	98,109,000	73,804,000
New Zealand.....	5,743,000	9,049,000	9,008,000	8,535,000	7,490,000
Total Australasia.....	51,806,000	73,612,000	102,271,000	106,644,000	81,384,000
Grand total.....	3,182,105,000	3,581,519,000	3,575,055,000	3,540,717,000	3,759,533,000

TABLE 14.—Total production of wheat in countries named in Table 13, 1891-1912.

Year.	Production.	Year.	Production.	Year.	Production.	Year.	Production.
	<i>Bushels.</i>		<i>Bushels.</i>		<i>Bushels.</i>		<i>Bushels.</i>
1891.....	2,432,322,000	1897.....	2,236,268,000	1903.....	3,189,813,000	1909.....	3,581,519,000
1892.....	2,481,805,000	1898.....	2,948,305,000	1904.....	3,163,542,000	1910.....	3,575,055,000
1893.....	2,559,174,000	1899.....	2,788,885,000	1905.....	3,327,084,000	1911.....	3,540,717,000
1894.....	2,660,557,000	1900.....	2,640,751,000	1906.....	3,434,354,000	1912.....	3,759,533,000
1895.....	2,593,312,000	1901.....	2,955,975,000	1907.....	3,133,965,000		
1896.....	2,506,320,000	1902.....	3,090,116,000	1908.....	3,182,105,000		

TABLE 15.—Average yield of wheat in countries named, bushels per acre, 1890-1912.

Year.	United States.	Russia, European. <sup>1</sup>	Germany. <sup>1</sup>	Austria. <sup>1</sup>	Hungary proper. <sup>1</sup>	France. <sup>2</sup>	United Kingdom. <sup>2</sup>
Average:							
1890-1899.....	13.2	8.9	24.5	16.2	.....	18.6	31.2
1900-1909.....	14.1	9.7	28.9	18.0	17.5	20.5	33.1
1903.....	12.9	10.6	29.2	17.8	19.0	22.8	31.1
1904.....	12.5	11.5	29.5	19.5	16.3	18.5	27.8
1905.....	14.5	10.0	28.5	19.6	18.7	20.9	33.9
1906.....	15.5	7.7	30.3	20.3	22.5	20.2	34.8
1907.....	14.0	8.0	29.6	18.0	14.9	23.2	35.1
1908.....	14.0	8.8	29.7	21.0	17.5	19.6	33.4
1909.....	15.4	12.5	30.5	19.9	14.1	21.9	35.0
1910.....	13.9	11.2	29.6	19.5	19.8	15.9	31.4
1911.....	12.5	<sup>a</sup> 6.9	30.6	19.6	21.0	20.1	34.0
1912.....	15.9	<sup>a</sup> 10.2	33.7	22.4	19.7	20.7	30.1
Average (1903-1912).....	14.1	9.7	30.1	19.8	18.4	20.4	31.7

<sup>1</sup> Bushels of 60 pounds.<sup>2</sup> Winchester bushels.<sup>3</sup> Includes Asiatic Russia.

TABLE 16.—*Acres, production, value, and exports of wheat in the United States, 1849-1912.*

Year.	Acreage harvested.	Average yield per acre.	Production.		Average farm price per bushel Dec. 1.	Chicago cash price per bushel, No. 1 northern.				Domestic exports, including flour, fiscal year, beginning July 1.	Per cent of crop exported.		
						Farm value December 1.		December.				May of following year.	
						Acres.	Bushels.	Cts.	Dollars.			Low.	High.
1849 <sup>1</sup>	.....	.....	100,486,000	.....	.....	.....	.....	.....	.....	7,635,901	7.5		
1850 <sup>1</sup>	.....	.....	178,105,000	.....	.....	.....	.....	.....	.....	17,213,133	9.9		
1866	15,424,000	9.9	152,000,000	152.7	232,110,000	129	145	185	211	12,646,941	8.3		
1867	18,322,000	11.6	212,441,000	145.2	308,387,000	126	140	134	161	26,323,014	12.4		
1868	18,460,000	12.1	224,037,000	108.5	243,033,000	80	88	87	96	29,717,201	13.3		
1869	19,181,000	13.6	260,147,000	76.5	199,025,000	63	76	79	92	53,900,780	20.7		
1869 <sup>1</sup>	.....	.....	287,746,000	.....	.....	.....	.....	.....	.....	.....	.....		
1870	18,993,000	12.4	235,885,000	94.4	222,767,000	91	98	113	120	52,574,111	22.3		
1871	19,944,000	11.6	230,722,000	114.5	264,076,000	107	111	120	143	38,995,755	16.9		
1872	20,858,000	12.0	249,997,000	111.4	278,522,000	97	108	112	122	52,014,715	20.8		
1873	22,172,000	12.7	281,255,000	106.9	300,670,000	96	106	105	114	91,510,398	32.5		
1874	24,967,000	12.3	308,103,000	86.3	265,881,000	78	83	78	94	72,912,817	23.7		
1875	26,382,000	11.1	292,136,000	89.5	261,397,000	82	91	89	100	74,750,682	25.6		
1876	27,627,000	10.5	289,356,000	97.0	280,743,000	104	117	130	172	57,043,936	19.7		
1877	26,278,000	13.9	364,194,000	105.7	385,089,000	103	108	98	113	92,141,626	25.3		
1878	32,109,000	13.1	420,122,000	77.6	325,814,000	81	84	91	102	150,502,506	35.8		
1879	32,546,000	13.8	448,757,000	110.8	497,030,000	122	133½	112½	119	180,304,181	40.2		
1879 <sup>1</sup>	.....	.....	459,483,000	.....	.....	.....	.....	.....	.....	.....	.....		
1880	37,987,000	13.1	498,550,000	95.1	474,202,000	93½	109½	101	112½	186,321,514	37.4		
1881	37,709,000	10.2	383,280,000	119.2	456,880,000	124½	129	123	140	121,892,389	31.8		
1882	37,067,000	13.6	504,185,000	88.4	445,602,000	91½	94½	108	113½	147,811,316	29.3		
1883	36,456,000	11.6	421,086,000	91.1	383,649,000	94½	99½	85	94½	111,534,182	26.5		
1884	39,476,000	13.0	512,765,000	64.5	330,862,000	69½	76½	85½	90½	132,570,366	25.9		
1885	34,189,000	10.4	357,112,000	77.1	275,320,000	82½	89	72½	79	94,565,793	26.5		
1886	36,806,000	12.4	457,218,000	68.7	314,226,000	75½	79½	80½	88½	153,804,969	33.6		
1887	37,642,000	12.1	456,329,000	68.1	310,613,000	75½	79½	81½	89½	119,625,344	26.2		
1888	37,336,000	11.1	415,868,000	92.6	385,248,000	96½	105½	77½	95½	88,600,743	21.3		
1889	38,124,000	12.9	490,560,000	69.8	342,492,000	76½	80½	89½	100	109,430,467	22.3		
1889 <sup>1</sup>	.....	.....	468,374,000	.....	.....	.....	.....	.....	.....	.....	.....		
1890	36,087,000	11.1	399,262,000	83.8	334,774,000	87½	92½	98½	108½	106,181,316	26.6		
1891	39,917,000	15.3	611,780,000	83.9	513,473,000	89½	96½	80	85½	225,665,811	36.9		
1892	38,554,000	13.4	515,949,000	62.4	322,112,000	69½	73	68½	76½	191,912,635	37.2		
1893	34,629,000	11.4	396,132,000	53.8	213,171,000	59½	64½	52½	60½	164,283,129	41.5		
1894	34,882,000	13.2	460,267,000	49.1	225,902,000	52½	63½	60½	67½	144,812,718	31.5		
1895	34,047,000	13.7	467,103,000	50.9	237,939,000	53½	64½	57½	67½	126,443,968	27.1		
1896	34,619,000	12.4	427,684,000	72.6	310,598,000	74½	93½	68½	97½	145,124,972	33.9		
1897	39,465,000	13.4	530,149,000	80.8	428,547,000	92	109	117	185	217,306,005	41.0		
1898	44,055,000	15.3	675,149,000	58.2	392,770,000	62½	70	68½	79½	222,618,420	33.0		
1899	44,593,000	12.3	547,304,000	58.4	319,545,000	64	69½	63½	67½	186,096,762	34.0		
1899 <sup>1</sup>	.....	.....	668,634,000	.....	.....	.....	.....	.....	.....	.....	.....		
1900	42,495,000	12.3	522,230,000	61.9	323,515,000	69½	74½	70	75½	215,990,073	41.4		
1901	49,896,000	15.0	748,460,000	62.4	467,360,000	73	79½	72½	76½	234,772,516	31.4		
1902	46,202,000	14.5	670,063,000	63.0	422,224,000	71½	77½	74½	80½	202,905,598	30.3		
1903	49,465,000	12.9	637,822,000	69.5	443,025,000	77½	87	87½	101½	120,727,613	18.9		
1904	44,075,000	12.5	552,400,000	92.4	510,490,000	115	122	89½	113½	44,112,910	8.0		
1905	47,854,000	14.5	692,979,000	74.8	518,373,000	82½	90	80½	87½	97,609,007	14.1		
1906	47,306,000	15.5	735,261,000	66.7	490,333,000	272½	275	84	106	146,700,425	20.0		
1907	45,211,000	14.0	634,087,000	87.4	554,437,000	210½	2109	2103	2111½	163,043,669	25.7		
1908	47,557,000	14.0	664,602,000	92.8	616,826,000	106½	112	126½	137	114,268,468	17.2		
1909	46,723,000	15.8	737,189,000	99.0	730,046,000	106	119½	100	119½	87,364,318	12.8		
1909 <sup>1</sup>	.....	.....	883,350,000	.....	.....	.....	.....	.....	.....	.....	.....		
1910	45,681,000	13.9	635,121,000	88.3	561,051,000	104	110	98	106	69,311,760	10.9		
1911	49,543,000	12.5	621,338,000	87.4	543,063,000	105	110	115	122	79,689,404	12.8		
1912	45,814,000	15.9	730,267,000	76.0	555,280,000	85	90½	.....	.....	.....	.....		

<sup>1</sup> Census figures.

<sup>2</sup> No. 2, red winter.

<sup>3</sup> Figures adjusted to census basis.

TABLE 17.—*Acres, production, and farm value December 1 of winter and spring wheat, by States, in 1912, and United States totals, 1890 to 1911.*

State and year.	Winter wheat.					Spring wheat.				
	Acres.	Average yield per acre.	Production.	Average farm price Dec. 1.	Farm value Dec. 1.	Acres.	Average yield per acre.	Production.	Average farm price Dec. 1.	Farm value Dec. 1.
	<i>Acres.</i>	<i>Bu.</i>	<i>Bushels.</i>	<i>Cts.</i>	<i>Dollars.</i>	<i>Acres.</i>	<i>Bu.</i>	<i>Bushels.</i>	<i>Cts.</i>	<i>Dollars.</i>
Me.										
Vt.										
N. Y.	335,000	16.0	5,360,000	99	5,306,000	3,000	23.5	70,000	103	72,000
N. J.	79,000	18.5	1,462,000	98	1,433,000	1,000	25.0	25,000	98	24,000
Pa.	1,240,000	18.0	22,320,000	95	21,204,000					
Del.	111,000	17.5	1,942,000	96	1,864,000					
Md.	599,000	15.0	8,985,000	95	8,536,000					
Va.	741,000	11.6	8,596,000	101	8,682,000					
W. Va.	233,000	14.5	3,378,000	101	3,412,000					
N. C.	598,000	8.9	5,322,000	111	5,907,000					
S. C.	79,000	9.2	727,000	119	865,000					
Ga.	132,000	9.3	1,228,000	122	1,498,000					
Ohio.	1,220,000	8.0	9,760,000	98	9,565,000					
Ind.	1,260,000	8.0	10,080,000	93	9,374,000					
Ill.	1,183,000	8.3	9,819,000	88	8,641,000					
Mich.	700,000	10.0	7,000,000	96	6,720,000					
Wis.	87,000	19.5	1,696,000	83	1,408,000	101,000	18.5	1,868,000	83	1,550,000
Minn.						4,325,000	15.5	67,038,000	73	48,938,000
Iowa.	300,000	23.0	6,900,000	78	5,382,000	350,000	17.0	5,950,000	78	4,641,000
Mo.	1,900,000	12.5	23,750,000	80	21,375,000					
N. Dak.						7,900,000	18.0	143,820,000	69	99,236,000
S. Dak.						3,675,000	14.2	52,185,000	69	36,008,000
Nebr.	2,825,000	18.0	50,850,000	69	35,086,000	298,000	14.1	4,202,000	69	2,899,000
Kans.	5,900,000	15.5	91,450,000	74	67,673,000	56,000	15.0	840,000	74	622,000
Ky.	686,000	10.0	6,860,000	99	6,791,000					
Tenn.	674,000	10.5	7,077,000	100	7,077,000					
Ala.	30,000	10.6	318,000	113	359,000					
Miss.	8,000	12.0	96,000	97	93,000					
Tex.	735,000	15.0	11,025,000	93	10,253,000					
Okla.	1,570,000	12.8	20,090,000	75	15,072,000					
Ark.	94,000	10.0	940,000	94	884,000					
Mont.	475,000	24.5	11,638,000	64	7,448,000	328,000	23.5	7,708,000	64	4,933,000
Wyo.	32,000	28.0	896,000	80	717,000	44,000	29.2	1,285,000	80	1,028,000
Colo.	193,000	24.5	4,728,000	73	3,451,000	260,000	24.0	6,240,000	73	4,555,000
N. Mex.	33,000	20.0	660,000	90	594,000	26,000	22.0	572,000	90	515,000
Ariz.	21,000	31.0	651,000	110	716,000	2,000	28.0	56,000	110	62,000
Utah.	160,000	24.0	3,840,000	75	2,880,000	76,000	29.2	2,219,000	75	1,664,000
Nev.	15,000	27.5	412,000	100	412,000	24,000	30.2	725,000	100	725,000
Idaho.	335,000	28.0	9,614,000	66	6,345,000	175,000	28.3	4,952,000	66	3,268,000
Wash.	988,000	27.6	27,269,000	68	18,543,000	1,297,000	20.4	26,459,000	68	17,992,000
Oreg.	630,000	26.8	16,884,000	72	12,156,000	212,000	19.5	4,134,000	72	2,976,000
Cal.	370,000	17.0	6,290,000	93	5,850,000					
U. S.	26,571,000	15.1	399,919,000	80.9	323,572,000	19,243,000	17.2	330,348,000	70.1	231,708,000
1911	29,162,000	14.8	430,656,000	88.0	379,151,000	20,381,000	9.4	190,682,000	86.0	163,912,000
1910	27,329,000	15.9	434,142,000	88.1	382,318,000	18,352,000	11.0	200,979,000	88.9	178,733,000
1909	27,017,000	15.5	417,781,000	102.4	427,872,000	17,243,000	15.4	265,569,000	92.6	245,787,000
1908	30,349,000	14.4	437,908,000	93.7	410,330,000	17,208,000	13.2	226,694,000	91.1	206,496,000
1907	28,132,000	14.6	409,442,000	88.2	361,217,000	17,079,000	13.2	224,645,000	86.0	193,220,000
1906	29,600,000	16.7	492,888,000	68.3	336,435,000	17,706,000	13.7	242,373,000	68.3	153,898,000
1905	29,864,000	14.3	428,462,000	78.2	334,987,000	17,990,000	14.7	264,517,000	69.3	183,386,000
1904	26,866,000	12.4	332,935,000	97.8	325,611,000	17,209,000	12.8	219,464,000	84.2	184,879,000
1903	32,511,000	12.3	399,867,000	71.6	286,243,000	16,954,000	14.0	237,955,000	65.9	156,782,000
1902	28,581,000	14.4	411,789,000	64.8	266,727,000	17,621,000	14.7	258,274,000	60.2	155,497,000
1901	30,240,000	15.2	458,885,000	66.1	303,227,000	19,656,000	14.7	289,626,000	56.7	164,133,000
1900	26,236,000	13.3	350,025,000	63.3	221,668,000	16,259,000	10.6	172,204,000	59.1	101,847,000
1899	25,358,000	11.5	291,706,000	63.0	183,767,000	19,235,000	13.3	255,598,000	53.1	135,778,000
1898	25,745,000	14.9	382,492,000	62.2	237,736,000	18,310,000	16.0	232,657,000	53.0	155,034,000
1897	22,926,000	14.1	323,616,000	85.1	275,323,000	16,539,000	12.5	206,535,000	74.2	153,224,000
1896	22,794,000	11.8	267,934,000	77.0	206,270,000	11,825,000	13.3	159,750,000	65.3	104,328,000
1895	22,609,000	11.6	261,242,000	57.8	150,944,000	11,438,000	18.0	205,861,000	62.3	86,995,000
1894	23,519,000	14.0	329,290,000	49.8	164,022,000	11,364,000	11.5	130,977,000	47.2	61,880,000
1893	23,118,000	12.0	278,469,000	56.3	156,720,000	11,511,000	10.2	117,662,000	48.0	56,451,000
1892	26,209,000	13.7	359,416,000	65.1	234,037,000	12,345,000	12.7	156,531,000	56.3	88,075,000
1891	27,524,000	14.7	405,116,000	88.0	356,415,000	12,393,000	16.7	206,665,000	76.0	157,058,000
1890	23,520,000	10.9	255,374,000	87.5	223,362,000	12,567,000	11.4	143,890,000	77.4	111,411,000

TABLE 18.—*Acreage and production of wheat, by States, 1909-1912.*

State and division.	Acreage (000 omitted).				Production (000 omitted).			
	1912	1911	1910	1909 (cen- sus).	1912	1911	1910	1909 (cen- sus).
	<i>Acres.</i>	<i>Acres.</i>	<i>Acres.</i>	<i>Acres.</i>	<i>Bush.</i>	<i>Bush.</i>	<i>Bush.</i>	<i>Bush.</i>
Maine.....	3	3	3	4	70	63	89	85
Vermont.....	1	1	1	1	25	28	29	14
New York.....	335	345	355	289	5,360	6,728	8,414	6,664
New Jersey.....	79	84	84	84	1,462	1,462	1,554	1,489
Pennsylvania.....	1,240	1,289	1,309	1,226	22,320	17,402	23,300	21,564
N. Atlantic.....	1,658	1,722	1,752	1,604	29,237	25,683	33,386	29,816
Delaware.....	111	113	116	111	1,942	1,887	1,972	1,644
Maryland.....	599	605	604	590	8,985	9,378	10,510	9,463
Virginia.....	741	750	748	693	8,596	9,000	9,574	8,077
West Virginia.....	233	238	241	209	3,378	2,737	3,012	2,576
North Carolina.....	598	626	598	502	5,322	6,636	6,817	3,827
South Carolina.....	79	83	77	43	727	946	847	311
Georgia.....	132	145	141	93	1,228	1,740	1,480	753
S. Atlantic.....	2,493	2,560	2,525	2,241	30,178	32,324	34,212	26,651
Ohio.....	1,220	2,265	2,125	1,828	9,760	36,240	34,425	30,664
Indiana.....	1,260	2,337	2,256	2,083	10,080	34,354	35,194	33,936
Illinois.....	1,183	2,625	2,444	2,185	9,819	42,000	36,660	37,831
Michigan.....	700	1,025	936	802	7,000	18,450	16,848	16,026
Wisconsin.....	188	195	186	140	3,564	3,097	3,590	2,635
N. C. E. Miss. R.....	4,551	8,447	7,947	7,038	40,223	134,141	126,717	121,092
Minnesota.....	4,325	4,350	4,000	3,277	67,038	43,935	64,000	57,094
Iowa.....	650	647	532	527	12,850	10,622	11,174	8,056
Missouri.....	1,900	2,300	1,881	2,017	23,750	36,110	25,958	29,897
North Dakota.....	7,990	9,150	7,700	8,189	143,820	73,200	38,500	116,782
South Dakota.....	3,675	3,700	3,650	3,217	52,185	14,800	46,720	47,060
Nebraska.....	3,123	3,098	2,394	2,663	55,052	41,574	38,760	47,686
Kansas.....	5,956	4,810	4,490	5,973	92,290	51,387	63,236	77,564
N. C. W. Miss. R.....	27,619	28,055	24,647	25,863	446,985	271,628	288,348	384,079
Kentucky.....	686	780	767	681	6,860	9,906	9,818	8,739
Tennessee.....	674	720	711	620	7,077	8,280	8,319	6,517
Alabama.....	30	30	28	14	318	345	336	114
Mississippi.....	8	9	5	.....	96	108	70	5
Texas.....	735	700	700	326	11,025	6,580	10,500	2,561
Oklahoma.....	1,570	1,122	1,567	1,169	20,096	8,976	25,542	14,008
Arkansas.....	94	96	87	61	940	1,008	1,209	526
S. Central.....	3,797	3,457	3,865	2,871	46,412	35,203	55,794	32,470
Montana.....	803	429	350	258	19,346	12,299	7,700	6,252
Wyoming.....	76	69	56	42	2,181	1,794	1,400	736
Colorado.....	453	438	403	341	10,968	8,274	8,994	7,224
New Mexico.....	59	55	41	32	1,232	1,262	820	500
Arizona.....	23	27	27	20	707	800	603	363
Utah.....	236	225	198	179	6,059	5,025	4,370	3,944
Nevada.....	39	36	30	14	1,137	1,018	795	390
Idaho.....	510	517	472	399	14,566	15,860	10,658	10,238
Washington.....	2,285	2,230	2,101	2,118	53,728	50,661	35,571	40,920
Oregon.....	842	796	717	763	21,018	16,726	15,853	12,457
California.....	370	480	550	478	6,290	8,640	9,900	6,203
Far Western.....	5,696	5,302	4,945	4,644	137,232	122,359	96,664	89,227
United States.....	45,814	49,543	45,681	44,261	730,267	621,338	635,121	1,683,350

<sup>1</sup> Includes nearly 1,000 acres and 16,000 bushels in other States.



TABLE 19.—Total farm value and value per acre of wheat, by States, 1909–1912.

State and division.	Value, basis Dec. 1 price (000 omitted).				Value per acre, basis Dec. 1 price.			
	1912	1911	1910	1909	1912	1911	1910	1909
	<i>Dolls.</i>	<i>Dolls.</i>	<i>Dolls.</i>	<i>Dolls.</i>	<i>Dolls.</i>	<i>Dolls.</i>	<i>Dolls.</i>	<i>Dolls.</i>
Maine.....	72	69	91	94	24.20	23.10	30.29	31.13
Vermont.....	24	28	30	17	24.50	27.52	30.18	16.80
New York.....	5,306	6,392	8,077	7,397	15.84	18.52	22.75	25.64
New Jersey.....	1,433	1,404	1,523	1,623	18.13	16.70	18.13	19.29
Pennsylvania.....	21,204	16,010	21,436	23,505	17.10	12.42	16.38	19.18
North Atlantic.....	28,039	23,903	31,157	32,636	16.91	13.88	17.78	20.35
Delaware.....	1,864	1,698	1,775	1,709	16.80	15.03	15.30	15.39
Maryland.....	8,536	8,534	9,669	10,410	14.25	14.10	16.01	17.60
Virginia.....	8,682	8,640	9,287	9,289	11.72	11.52	12.42	13.46
West Virginia.....	3,412	2,792	3,072	2,911	14.64	11.73	12.75	13.90
North Carolina.....	5,907	6,769	7,499	4,860	9.88	10.81	12.54	9.65
South Carolina.....	865	1,164	1,067	453	10.95	14.02	13.86	10.51
Georgia.....	1,498	1,984	1,924	1,092	11.35	13.68	13.65	11.74
South Atlantic.....	30,764	31,581	34,293	30,724	12.34	12.34	13.58	13.71
Ohio.....	9,565	32,978	30,982	34,343	7.84	14.56	14.58	18.82
Indiana.....	9,874	30,575	30,619	37,330	7.44	13.08	13.57	17.93
Illinois.....	8,641	37,380	32,261	39,344	7.30	14.24	13.20	17.99
Michigan.....	6,720	16,236	14,995	17,949	9.60	15.84	16.02	22.40
Wisconsin.....	2,958	2,788	3,302	2,529	15.77	14.31	17.76	18.05
North Central East of Mississippi River.....	37,258	119,957	112,159	131,495	8.19	14.20	14.11	18.68
Minnesota.....	48,938	40,420	60,160	54,811	11.32	9.29	15.04	16.70
Iowa.....	10,023	9,348	9,497	7,492	14.42	14.43	17.85	14.23
Missouri.....	21,375	31,777	22,583	31,329	11.25	13.82	12.01	15.54
North Dakota.....	99,236	65,148	34,650	107,439	12.42	7.12	4.50	13.16
South Dakota.....	36,008	13,468	41,581	42,354	9.80	3.64	11.39	13.14
Nebraska.....	37,985	36,169	31,008	42,440	12.14	11.66	12.96	15.93
Kansas.....	68,295	46,762	53,118	74,461	11.47	9.74	11.84	12.48
North Central West of Mississippi River.....	321,860	243,092	252,597	360,326	11.65	8.66	10.25	13.93
Kentucky.....	6,791	9,114	9,131	9,701	9.90	11.68	11.90	14.21
Tennessee.....	7,077	7,949	8,153	7,494	10.50	11.04	11.47	12.08
Alabama.....	359	414	380	148	11.98	13.80	13.56	10.53
Mississippi.....	93	108	81	6	11.64	12.00	16.24	14.40
Texas.....	10,253	6,580	10,290	3,022	13.95	9.40	14.70	9.32
Oklahoma.....	15,072	8,258	22,222	14,148	9.60	7.36	14.18	12.12
Arkansas.....	884	907	1,136	579	9.40	9.45	13.07	9.46
South Central.....	40,529	33,330	51,393	35,098	10.67	9.64	13.30	12.23
Montana.....	12,381	9,470	6,622	5,439	15.42	22.10	18.92	21.05
Wyoming.....	1,745	1,687	1,330	728	22.96	24.44	28.75	17.42
Colorado.....	3,006	6,950	7,376	6,718	17.67	15.88	18.29	19.72
New Mexico.....	1,109	1,262	820	585	18.81	22.90	20.00	18.25
Arizona.....	778	760	724	504	33.77	28.12	26.76	25.02
Utah.....	4,544	3,518	3,671	3,550	19.28	15.61	18.56	19.98
Nevada.....	1,137	968	866	406	29.20	26.88	28.88	28.91
Idaho.....	9,613	10,468	7,674	8,907	18.88	20.26	16.27	22.36
Washington.....	36,535	35,969	27,746	38,056	15.98	16.12	13.18	17.95
Oregon.....	15,132	12,545	13,317	11,585	18.00	15.75	18.56	15.16
California.....	5,850	7,603	9,306	6,886	15.81	15.84	16.92	14.43
Far Western.....	96,830	91,200	79,452	83,364	17.00	17.20	16.07	17.95
United States.....	555,280	543,063	561,051	673,643	12.12	10.96	12.28	15.22

TABLE 20.—Yield per acre and price per bushel of wheat, by States.

State and division.	Yield per acre.							Farm price per bushel.											
	10-year averages.				1910	1911	1912	10-year averages for Dec. 1.				Dec. 1, 1910.	Dec. 1, 1911.	Quarterly, 1912.					
	1870-1879	1880-1889	1890-1899	1900-1909				1870-1879	1880-1889	1890-1899	1900-1909			Mar. 1.	June 1.	Sept. 1.	Dec. 1.		
	Bu.	Bu.	Bu.	Bu.	Bu.	Bu.	Bu.	Cts.	Cts.	Cts.	Cts.	Cts.	Cts.	Cts.	Cts.	Cts.	Cts.		
Me.....	14.0	13.6	18.3	24.0	29.7	21.0	23.5	152	128	96	100	102	110	.....	.....	.....	103		
Vt.....	16.6	16.9	20.6	21.9	29.3	27.8	25.0	139	117	91	98	103	99	99	124	107	98		
N. Y.....	14.8	14.7	17.2	17.4	23.7	19.5	16.0	126	102	82	90	96	95	95	110	99	99		
N. J.....	14.3	12.8	15.0	16.8	18.5	17.4	18.5	131	104	82	89	98	96	98	110	97	98		
Pa.....	13.8	12.6	15.3	16.5	17.8	13.5	18.0	123	99	77	87	92	92	97	111	96	95		
N. Atlan- tic.....	14.2	13.3	15.7	16.7	19.1	14.9	17.6	125.1	101.4	79.0	88.0	93.3	93.1	96.5	110.7	96.9	95.9		
Del.....	12.2	11.6	14.0	16.0	17.0	16.7	17.5	128	100	77	86	90	90	99	113	96	96		
Md.....	11.7	12.2	15.1	16.0	17.4	15.5	15.0	125	98	78	86	92	91	94	113	95	95		
Va.....	8.5	8.0	9.9	10.6	12.8	12.0	11.6	115	97	76	90	97	96	100	115	100	101		
W. Va.....	10.7	10.0	11.0	11.2	12.5	11.5	14.5	111	94	78	92	102	102	102	116	102	101		
N. C.....	7.4	6.0	7.0	8.2	11.4	10.6	8.9	119	106	84	101	110	102	108	125	111	111		
S. C.....	6.9	5.7	6.7	8.1	11.0	11.4	9.2	163	119	98	114	126	123	109	129	118	119		
Ga.....	7.5	6.0	7.3	8.3	10.5	12.0	9.3	136	115	95	110	130	114	121	126	124	122		
S. Atlan- tic.....	9.0	8.3	10.2	11.2	13.5	12.6	12.1	121.9	101.0	80.0	93.0	100.2	97.7	101.7	117.6	102.9	101.9		
Ohio.....	14.0	13.5	14.7	14.9	16.2	16.0	8.0	108	91	71	86	90	91	95	112	102	98		
Ind.....	13.0	13.1	13.3	14.2	15.6	14.7	8.0	100	87	69	84	87	89	94	110	95	93		
Ill.....	13.0	13.1	12.8	15.5	15.0	16.0	8.3	92	84	67	81	88	89	92	107	91	88		
Mich.....	14.7	15.3	14.7	14.5	18.0	18.0	10.0	109	88	72	84	89	88	91	109	101	96		
Wis.....	13.1	12.0	14.2	16.6	19.3	15.9	19.0	87	83	66	79	92	90	92	96	90	83		
N. C. E. M. R.....	13.5	13.4	13.5	14.9	15.9	15.9	8.8	98.6	87.2	69.3	83.1	88.5	89.4	93.2	109.1	96.3	92.6		
Minn.....	14.3	12.6	14.4	13.0	16.0	10.1	15.5	77	75	62	76	94	92	94	105	85	73		
Iowa.....	11.0	10.7	14.3	14.6	21.0	16.4	19.8	73	73	61	72	85	88	90	98	83	78		
Mo.....	12.2	11.8	11.4	13.4	13.8	15.7	12.5	92	80	64	78	87	88	92	106	93	90		
N. Dak.....	.....	13.0	13.1	12.1	5.0	8.0	18.0	.....	64	56	72	90	89	90	99	83	69		
S. Dak.....	.....	10.7	12.1	12.8	4.0	14.2	.....	.....	55	71	89	91	92	101	80	69	.....		
Nebr.....	12.5	11.0	12.1	17.5	16.2	13.4	17.6	67	64	55	67	80	87	90	97	77	69		
Kans.....	14.3	13.8	12.3	14.0	14.1	10.7	15.5	86	69	57	71	84	91	95	101	78	74		
N. C. W. M. R.....	12.6	11.9	12.7	13.5	11.7	9.7	16.2	77.8	72.3	58.2	72.3	87.6	89.5	92.0	101.0	82.6	72.0		
Ky.....	10.4	9.4	11.6	11.5	12.8	12.7	10.0	98	89	71	87	93	92	97	113	99	99		
Tenn.....	7.8	6.6	9.4	9.6	11.7	11.5	10.5	101	91	74	90	98	96	101	116	102	100		
Ala.....	7.8	6.0	8.1	9.6	12.0	11.5	10.6	124	112	92	102	113	120	115	118	118	113		
Miss.....	9.0	5.6	8.5	10.0	14.0	12.0	12.0	140	114	86	94	116	100	.....	103	100	97		
Texas.....	13.8	10.1	11.6	10.8	15.0	9.4	15.0	126	95	74	89	98	100	101	111	88	93		
Okla.....	.....	.....	13.8	12.8	16.3	8.0	12.8	.....	.....	58	73	87	92	99	98	77	75		
Ark.....	9.4	7.5	8.9	9.5	13.9	10.5	10.0	113	99	72	85	94	90	94	105	91	94		
S. Central	9.0	8.0	10.8	11.3	14.4	10.2	12.2	104.7	92.6	71.5	82.9	92.1	94.7	99.1	109.2	91.6	87.3		
Mont.....	.....	17.5	24.3	26.3	22.0	28.7	24.1	.....	87	67	73	86	77	82	85	70	64		
Wyo.....	.....	17.4	21.5	24.5	25.0	26.0	28.7	.....	88	68	80	95	94	92	110	85	80		
Colo.....	119.4	19.4	20.4	25.1	23.3	18.9	24.2	1102	86	63	75	82	84	83	93	78	73		
N. Mex.....	.....	13.6	17.5	21.2	20.0	22.9	20.9	.....	97	76	88	100	100	100	104	96	90		
Ariz.....	.....	13.8	18.5	23.1	22.3	29.6	30.7	.....	94	78	106	120	95	95	101	94	110		
Utah.....	.....	17.2	20.7	24.7	22.1	22.3	25.7	.....	75	62	75	84	70	78	96	75	75		
Nev.....	21.1	17.5	20.9	28.0	26.5	28.3	29.2	154	96	78	93	109	95	90	100	105	100		
Idaho.....	.....	17.0	21.8	24.2	22.6	30.7	28.6	.....	86	61	69	72	66	72	90	66	66		
Wash.....	.....	16.9	19.4	23.1	16.9	22.7	23.5	.....	73	58	69	78	71	76	91	69	68		
Oreg.....	18.7	16.4	17.8	19.5	22.1	21.0	25.0	89	74	63	72	84	75	78	92	72	72		
Cal.....	13.3	12.5	12.3	12.6	18.0	18.0	17.0	118	83	71	84	94	88	92	104	94	93		
Far West- ern.....	14.1	14.1	15.5	19.1	19.5	23.1	24.1	112.2	81.2	66.0	74.2	82.2	74.5	78.8	92.3	72.8	70.5		
United States..	12.3	12.0	13.2	14.1	13.9	12.5	15.9	99.4	83.5	65.4	77.0	88.3	87.4	90.7	102.8	85.8	76.0		

1 The Territories.

TABLE 21.—Condition of wheat crop, United States, on first of months named, 1888-1913.

Year.	Winter wheat.						Spring wheat.			
	Decem-ber of previous year.	April.	May.	June.	July.	When har-vested. <sup>1</sup>	June.	July.	August.	When har-vested.
	<i>P. ct.</i>	<i>P. ct.</i>	<i>P. ct.</i>	<i>P. ct.</i>	<i>P. ct.</i>	<i>P. ct.</i>	<i>P. ct.</i>	<i>P. ct.</i>	<i>P. ct.</i>	<i>P. ct.</i>
1888	95.9	82.0	73.1	73.3	75.6	77.3	92.8	95.9	87.3	.....
1889	96.8	94.0	96.0	93.1	92.0	87.5	94.4	83.3	81.2	.....
1890	95.3	81.0	80.0	78.1	76.2	75.5	91.3	94.4	83.2	.....
1891	98.4	96.9	97.9	96.6	96.2	96.9	92.6	94.1	95.5	.....
1892	85.3	81.2	84.0	88.3	89.6	85.3	92.3	90.9	87.3	.....
1893	.....	.....	.....	.....	.....	.....	.....	.....	.....	.....
1894	87.4	77.4	75.4	75.5	77.7	74.0	86.4	74.1	67.0	.....
1895	91.5	86.7	81.4	83.2	83.9	83.7	88.0	68.4	67.1	.....
1896	89.0	81.4	82.9	71.1	65.8	75.4	97.8	102.2	95.9	.....
1897	81.4	77.1	82.7	77.9	75.6	74.6	99.9	93.3	78.9	.....
1898	99.5	81.4	80.2	78.5	81.2	85.7	89.6	91.2	86.7	.....
1899	.....	86.7	86.5	90.8	85.7	86.7	100.9	95.0	96.5	.....
1900	92.6	77.9	76.2	67.3	65.6	70.9	91.4	91.7	83.6	.....
1901	97.1	82.1	88.9	82.7	80.8	69.6	87.3	55.2	56.4	.....
1902	97.1	91.7	94.1	87.8	88.3	82.8	92.0	95.6	80.3	.....
1903	86.7	78.7	76.4	76.1	77.0	80.0	95.4	92.4	89.7	.....
1904	.....	.....	.....	.....	.....	.....	.....	.....	.....	.....
1905	99.7	97.3	92.6	82.2	78.8	74.7	95.9	82.5	77.1	.....
1906	86.6	76.5	76.5	77.7	78.7	.....	93.4	93.7	87.5	66.2
1907	82.9	91.6	92.5	85.5	82.7	.....	93.7	91.0	89.2	87.3
1908	94.1	89.1	90.9	82.7	85.6	.....	93.4	91.4	86.9	83.4
1909	94.1	89.9	82.9	77.4	78.3	.....	88.7	87.2	79.4	77.1
1910	.....	.....	.....	.....	.....	.....	.....	.....	.....	.....
1911	91.1	91.3	89.0	86.0	80.6	.....	95.0	89.4	80.7	77.6
1912	85.3	82.2	83.5	80.7	82.4	.....	95.2	92.7	91.6	88.6
1913	95.8	80.8	82.1	80.0	81.5	.....	92.8	61.6	61.0	63.1
.....	82.5	83.3	86.1	80.4	76.8	.....	94.6	73.8	59.8	56.7
.....	86.6	80.6	79.7	74.3	73.3	.....	95.8	89.3	90.4	90.8
.....	93.2	.....	.....	.....	.....	.....	.....	.....	.....	.....

<sup>1</sup> Includes both winter and spring.

TABLE 22.—Per cent of winter wheat area sown which was abandoned (not harvested).

Year.	Per cent.	Year.	Per cent.	Year.	Per cent.
1899	13.5	1904	15.4	1909	7.2
1900	11.8	1905	4.6	1910	14.4
1901	6.7	1906	5.5	1911	9.2
1902	15.2	1907	11.2	1912	20.1
1903	2.8	1908	4.2	.....	.....

TABLE 23.—Farm price of wheat per bushel, on first of each month, 1911-1912.

Month.	United States.		North Atlantic States.		South Atlantic States.		N. Central States east of Miss. R.		N. Central States west of Miss. R.		South Central States.		Far West-ern States.	
	1912	1911	1912	1911	1912	1911	1912	1911	1912	1911	1912	1911	1912	1911
	<i>Cts.</i>	<i>Cts.</i>	<i>Cts.</i>	<i>Cts.</i>	<i>Cts.</i>	<i>Cts.</i>	<i>Cts.</i>	<i>Cts.</i>	<i>Cts.</i>	<i>Cts.</i>	<i>Cts.</i>	<i>Cts.</i>	<i>Cts.</i>	<i>Cts.</i>
January	88.0	88.6	93.4	91.5	98.8	101.1	90.4	89.6	90.1	87.3	96.1	95.0	74.5	79.8
February	90.4	89.8	95.8	91.6	101.0	102.8	93.0	91.0	93.1	89.1	96.7	96.6	83.3	79.2
March	90.7	85.4	95.5	89.6	101.7	100.5	93.2	85.8	92.0	83.6	99.1	92.7	78.8	77.2
April	92.5	83.8	98.2	88.0	104.7	97.5	95.3	83.5	93.9	82.0	99.4	92.7	79.7	76.0
May	99.7	84.6	103.4	87.4	112.8	97.8	105.9	83.3	99.1	83.7	105.1	91.2	88.3	77.8
June	102.8	86.3	110.7	90.0	117.6	98.9	109.1	85.5	101.0	84.2	109.2	93.5	92.3	81.5
July	99.0	84.3	111.0	88.0	114.4	95.3	105.5	82.3	99.0	82.9	100.3	87.0	84.9	82.8
August	89.7	82.7	101.0	86.0	103.1	93.4	96.0	78.6	87.9	82.1	91.5	84.7	80.2	82.2
September	85.8	84.8	96.9	86.5	102.9	96.0	96.3	82.3	82.6	86.1	91.6	89.5	72.8	74.9
October	83.4	88.4	95.2	88.8	103.0	98.1	95.3	87.1	78.4	90.7	91.6	91.6	71.8	76.0
November	83.8	91.5	96.0	91.6	104.8	100.7	95.6	91.8	78.8	94.3	94.0	95.9	71.0	75.5
December	76.0	87.4	95.9	93.1	101.9	97.7	92.6	89.4	72.0	89.5	87.3	94.7	70.5	74.5

TABLE 24.—Wholesale price of wheat per bushel, 1899–1912.

Date.	New York.		Baltimore.		Chicago.		Detroit.		St. Louis.		Minneapolis.		San Francisco.	
	No. 2 red winter.		Southern, No. 2 red.		No. 1 northern spring. <sup>1</sup>		No. 2 red.		No. 2 red winter.		No. 1 northern. <sup>2</sup>		No. 1 California (per 100 lbs.).	
	Low.	High.	Low.	High.	Low.	High.	Low.	High.	Low.	High.	Low.	High.	Low.	High.
	Cts.	Cts.	Cts.	Cts.	Cts.	Cts.	Cts.	Cts.	Cts.	Cts.	Cts.	Cts.	Dolls.	Dolls.
1899.....	72½	87½	68½	81½	64	79½	67½	80½	68	81½	60	73½	0.96½	1.18½
1900.....	72½	96½	70	90	61½	87½	66½	91	66½	86½	62	88½	1.90	1.07
1901.....	72½	89½	69½	85	63½	79½	66½	90½	61½	88½	60½	77½	.95	1.06½
1902.....	73½	94½	66½	87½	67½	95	68½	93½	63	92½	66½	80½	1.05	1.45
1903.....	78½	99½	76½	88½	70½	93	74½	94	69½	94	73½	100	1.32½	1.55
1904.....	92½	126½	82	118½	81½	122	92	123	89½	121	84½	124½	1.23½	1.50
1905.....	84½	125½	73	119½	82½	124	80	124	82	120	75½	124½	1.35	1.55
1906.....	77	97	68	91	71	87½	72	93½	68½	99½	69½	85½	.....	.....
1907.....	80	116½	74	111½	79	122	75	106½	74	109½	76½	119½	1.22½	1.80½
1908.....	95½	115	89	106½	102	124	89½	107	89	110	98½	125	1.55	1.77½
1909.....														
January.....	106½	111½	103½	108½	107	111½	104½	108½	107	115	107½	111½	1.70	1.75
February.....	110½	126½	108½	128	110½	121	108½	125	114	130	110	116½	1.72½	2.05
March.....	121½	128½	122½	128½	113½	121½	120	130	126	138	112½	117½	1.85	2.15
April.....	127½	141	130	145	119	131½	130	141	135	152½	118½	129½	1.97½	2.15
May.....	140½	146½	145	150½	126½	137	141	155	148	160	127½	135½	2.10	2.15
June.....	146½	150½	152	160	129	136	143	157	128	166	128½	138½	2.10	2.15
July.....	114½	125½	112	122	126½	140	107	140	105½	146	123	135	2.05	2.15
August.....	108	119½	99½	112	104½	136	105½	109	102	111	97½	144½	1.75	2.00
September.....	107½	114½	100	113	104	107	107	108	105	122	97½	101½	1.65	1.80
October.....	.....	.....	113½	119½	103	109½	117½	127	116	129	99½	106½	1.65	2.00
November.....	120	126	114	118	102½	112	117½	122½	114	127	101½	107½	1.80	1.90
December.....	123	127½	116½	122	106	119½	119½	126	116	132	105½	115½	1.95	2.00
Year.....	106½	150½	99½	160	103	140	104½	157	102	166	97½	144½	1.65	2.15
1910.....														
January.....	127	131	123½	128	110½	116½	124	121	123	135	110½	116½	1.90	2.05
February.....	128	130	124	127½	111½	119	123	126	124	130	110½	116½	1.87½	2.00
March.....	124½	129½	118½	125	113	118½	116½	123	119½	127½	112	116½	1.75	1.95
April.....	112½	123½	105½	119½	108½	118½	106	118	105	122	106½	116½	1.55	1.80
May.....	106½	117	104½	109½	100	119½	103	114	100	123	103	114½	1.50	1.58½
June.....	104	109	94	101	100	114	104½	107	92	116	102½	117	1.40	1.50
July.....	107	118	92½	104	111	129½	103	110	102	114½	113	129½	1.42½	1.70
August.....	106½	112½	97½	106	117	125½	99½	102½	99	108	109½	123	1.60	1.70
September.....	101	108	90	104½	111	117	97	102½	97	105	109	115	1.50	1.65
October.....	95½	104	90	98½	103	114	93½	99	95	104	102	112½	1.42½	1.55
November.....	94½	98½	88½	95½	101	109	91	96½	92½	99	99½	107	1.40	1.50
December.....	96	99½	95½	97	104	110	94½	90½	94	103	100½	106	1.45	1.52½
Year.....	94½	131	88½	128	100	129½	91	127	92	135	99½	129½	1.40	2.05
1911.....														
January.....	97½	101	94½	99	103	112	94½	99	96½	108	101½	110½	1.47½	1.55
February.....	91½	98½	90½	95½	97	107	89½	95½	91	104½	95½	104½	1.45	1.52½
March.....	91½	96½	89½	92½	95	102	84½	90½	85½	97	92½	100½	1.40	1.52½
April.....	90½	95½	89½	93	93	104	83½	89½	85	95	91½	101	1.47½	1.52½
May.....	95	98	92	96½	98	106	89½	93	90	98	96	102	1.40	1.50
June.....	93½	99	90	93	94	103	87	93½	85½	92½	93	100	1.40	1.52½
July.....	90½	95½	87	91½	93½	108½	84½	88½	91½	96½	95	102½	1.42½	1.52½
August.....	94½	97½	90	93	96	115	86½	90½	85½	91	101	109½	1.35	1.47½
September.....	96½	101½	90½	95½	100	112	88½	91½	88	100	102½	111	1.42½	1.47½
October.....	98½	105½	93½	100½	108	117	91	100½	98	103½	105½	112	1.47½	1.50
November.....	96½	100	91½	95½	107	112	96½	97½	93	99	101	106½	1.47	1.52½
December.....	94½	98½	91½	94½	105	110	93	97½	94	100	98½	106½	1.45	1.52½
Year.....	90½	105½	87	100½	93	117	83½	100½	85	108	91½	112½	1.35	1.55
1912.....														
January.....	98½	103½	95½	95½	107	114	96½	100½	92½	103	105	109½	1.50	1.52½
February.....	101½	105½	.....	.....	108	115	95½	100	98	102½	103½	108	1.51½	1.57½
March.....	104	108½	103½	103½	108	115	98½	100½	101	105	106½	109½	1.55	1.62½
April.....	106	123	107½	116½	108	122	99	118½	102	121	105½	118½	1.63½	1.90
May.....	118	127	116½	116½	115	122	114	120	116	125½	113½	118½	1.75	1.90
June.....	117	123	.....	.....	113	120	111½	115½	106	119	111½	115½	1.60	1.75
July.....	106½	118½	97	106	105	116	101½	112	98	115½	103½	112½	1.57½	1.65
August.....	106	108½	97	103½	95	111	105½	110½	98	112	90½	108½	1.47½	1.57½
September.....	103½	106½	94½	99½	90½	97	105½	107½	98	110	85½	91½	1.42½	1.52½
October.....	104	108	97½	104½	91	97	106½	111	103	113	86	92½	1.42½	1.50
November.....	105	108	98	102½	85	92	105½	108½	94	109	80½	88½	1.42½	1.50
December.....	105	109	98	102½	85	90½	105½	111½	100	110½	80½	84½	1.40	1.45
Year.....	98½	127	94½	116½	85	122	95½	120	92½	125½	80½	118½	1.40	1.90

<sup>1</sup>No grade, 1899 to 1901.

<sup>2</sup>No. 2 northern, 1899 and 1900.

TABLE 25.—Wholesale price of wheat flour per barrel, by months, 1908-1912.

Date.	Chicago.		Cincinnati.		New York.		St. Louis.		Chicago.	
	Winter patents.		Winter family.		Winter patents.		Winter patents.		Spring patents.	
	Low.	High.	Low.	High.	Low.	High.	Low.	High.	Low.	High.
1908.										
January.....	\$4.50	\$4.90	\$3.90	\$4.00	\$4.75	\$5.15	\$4.65	\$4.90	\$5.30	\$5.75
February.....	4.30	4.65	3.70	3.90	4.50	5.03	4.40	4.85	5.05	5.35
March.....	4.30	4.90	3.90	4.00	4.65	5.05	4.60	4.85	5.25	5.60
April.....	4.20	4.80	3.60	3.90	4.60	5.00	4.50	4.80	4.90	5.25
May.....	4.20	4.95	3.70	3.95	4.60	4.90	4.55	4.90	5.10	5.70
June.....	4.20	4.85	3.25	3.95	4.35	4.90	4.40	4.85	5.10	5.45
July.....	4.15	4.70	3.25	3.55	4.30	4.70	4.40	4.65	5.10	5.65
August.....	4.00	4.60	3.25	3.75	4.30	4.65	4.35	4.80	5.50	5.70
September.....	4.05	4.75	3.45	3.95	4.25	4.85	4.40	4.90	5.10	5.75
October.....	4.35	4.85	3.70	4.00	4.35	4.90	4.60	4.90	5.20	5.50
November.....	4.40	4.85	3.75	4.10	4.40	5.10	4.65	5.10	5.15	5.40
December.....	4.50	5.10	3.85	4.10	4.60	5.20	4.80	5.10	5.25	5.60
Year.....	4.00	5.10	3.25	4.10	4.25	5.20	4.35	5.10	4.90	5.75
1909.										
January.....	4.75	5.20	3.95	4.15	4.60	5.10	4.80	5.25	5.35	5.55
February.....	4.75	5.60	4.00	4.50	4.70	5.80	5.10	6.25	5.50	5.90
March.....	5.30	5.75	4.50	4.95	5.35	5.95	5.80	6.40	5.40	6.00
April.....	5.35	6.70	4.85	5.35	5.35	6.40	6.10	7.00	5.40	6.25
May.....	6.30	6.60	5.15	5.75	6.10	6.85	6.25	7.00	5.80	6.40
June.....	6.30	6.75	5.55	5.85	6.40	7.10	6.50	7.00	6.00	7.00
July.....	6.00	6.60	4.80	5.75	5.90	6.75	4.80	6.50	6.00	6.40
August.....	4.70	5.40	4.25	5.60	5.10	6.00	4.60	5.25	5.60	6.16
September.....	4.65	5.10	4.25	4.70	4.85	5.30	4.90	5.50	5.80	6.40
October.....	4.65	5.90	4.35	4.80	5.00	5.85	5.40	6.10	5.90	6.15
November.....	5.00	5.80	4.50	4.80	5.10	5.83	5.60	5.85	6.00	6.35
December.....	5.10	5.70	4.50	5.00	5.10	5.75	5.55	6.10	6.25	6.60
Year.....	4.65	6.75	3.95	5.85	4.60	7.10	4.60	7.00	5.35	7.00
1910.										
January.....	5.20	5.80	4.75	5.10	5.25	5.80	5.60	6.20	6.20	6.60
February.....	5.15	5.70	4.85	5.10	5.35	5.90	5.60	6.00	6.20	6.50
March.....	5.30	5.70	4.40	5.10	5.50	5.90	5.50	6.00	6.40	6.55
April.....	5.00	5.55	4.20	4.75	5.00	5.75	5.00	5.80	6.00	6.55
May.....	4.80	5.25	3.90	4.55	4.40	5.20	5.00	5.45	6.10	6.45
June.....	4.50	5.10	3.70	4.00	4.25	4.85	4.90	5.35	6.00	6.55
July.....	4.60	5.50	3.25	3.70	4.40	5.25	4.90	5.50	6.55	7.00
August.....	4.45	5.30	3.25	3.50	4.50	5.10	4.70	5.00	6.40	6.80
September.....	4.35	5.15	3.15	3.50	4.50	4.85	4.55	5.00	6.30	6.50
October.....	4.10	4.95	3.10	3.40	4.25	4.75	4.40	4.90	6.20	6.40
November.....	4.10	4.80	3.10	3.30	4.10	4.70	4.35	4.80	6.00	6.35
December.....	4.00	4.75	3.10	3.30	4.15	4.70	4.40	4.75	6.20	6.35
Year.....	4.00	5.80	3.10	5.10	4.10	5.90	4.35	6.20	6.00	7.00
1911.										
January.....	4.20	4.80	3.10	3.40	4.50	4.65	4.50	5.25	6.30	6.55
February.....	4.00	4.70	3.15	3.50	4.25	4.45	4.35	5.00	5.60	6.40
March.....	3.75	4.35	3.10	3.40	4.20	4.25	4.25	4.75	5.30	5.70
April.....	3.75	4.30	3.10	3.35	4.10	4.25	4.10	4.75	5.25	5.50
May.....	3.80	4.50	3.00	3.25	4.35	4.35	4.15	4.60	5.40	5.90
June.....	3.80	4.50	2.80	3.25	4.25	4.35	4.10	4.60	5.10	5.75
July.....	3.60	4.40	2.60	3.10	4.25	4.35	3.90	4.50	5.40	5.70
August.....	3.60	4.50	2.60	2.85	4.35	4.60	4.10	4.40	5.50	6.10
September.....	3.90	4.80	2.70	3.60	4.50	4.55	4.10	4.65	5.70	6.00
October.....	4.15	5.40	3.30	3.70	4.55	4.80	4.50	4.90	6.00	6.25
November.....	4.00	5.30	3.40	3.70	4.60	4.75	4.50	4.90	5.75	6.15
December.....	3.75	5.05	3.40	3.65	4.50	4.55	4.40	4.80	5.70	6.00
Year.....	3.60	5.40	2.60	3.70	4.60	4.80	3.90	5.25	5.10	6.55
1912.										
January.....	3.75	4.35	3.40	3.65	4.25	4.50	4.50	4.90	4.50	4.90
February.....	3.90	4.45	3.40	3.65	4.25	4.55	4.50	4.90	4.75	5.10
March.....	4.00	4.35	3.40	3.80	4.35	4.55	4.40	5.00	4.80	5.10
April.....	4.10	5.20	3.55	4.25	4.50	5.10	4.50	5.75	4.65	5.20
May.....	4.90	5.45	4.00	4.50	5.20	5.50	5.10	5.85	4.95	5.60
June.....	5.05	5.30	4.25	4.50	5.15	5.40	5.10	5.85	5.00	5.40
July.....	4.60	5.30	4.10	4.50	4.50	5.20	5.00	5.60	4.70	5.30
August.....	4.50	4.70	4.10	4.30	4.50	4.65	4.20	4.75	4.35	4.90
September.....	4.65	5.00	4.10	4.30	4.50	4.65	4.40	4.65	4.15	4.50
October.....	4.50	5.00	4.00	4.25	4.50	4.75	4.50	4.90	4.10	4.50
November.....	4.50	4.90	4.00	4.15	4.50	4.75	4.50	4.85	4.20	4.40
December.....	4.65	4.90	4.00	4.15	4.50	4.70	4.60	4.80	4.00	4.40
Year.....	3.75	5.45	3.40	4.50	4.25	5.50	4.20	5.85	4.00	5.60

1 Winter straights in 1912.

TABLE 26.—*International trade in wheat, calendar years 1907–1911.*

["Temporary" imports into Italy of wheat, to be used for manufacturing products for export, are subtracted from the total imports as given in the official Italian returns. The item "edible seeds and grains, not elsewhere specified," given in the statistics of imports for Mexico, is found to consist chiefly of wheat. In the trade returns of Chile the item *trigo mote* (prepared corn) which might easily be confused with *trigo* (wheat) is omitted. See "General note," p. 564.]

## EXPORTS.

Country.	1907	1908	1909	1910	1911
	<i>Bushels.</i>	<i>Bushels.</i>	<i>Bushels.</i>	<i>Bushels.</i>	<i>Bushels.</i>
Argentina.....	98,501,601	133,609,563	92,377,517	69,209,449	83,993,460
Australia.....	28,784,130	15,027,388	31,549,498	47,761,895	55,147,840
Austria-Hungary.....	683,007	14,719	10,872	28,476	15,160
Belgium.....	17,852,016	24,178,234	22,844,944	22,897,924	22,723,350
British India.....	37,515,771	4,289,344	34,712,087	40,480,702	52,603,245
Bulgaria.....	8,845,415	7,818,260	5,912,621	8,688,073	11,121,995
Canada.....	37,508,057	52,502,903	49,428,195	46,425,872	60,474,020
Chile.....	1,297,752	4,946,808	4,015,335	2,246,921	509,261
Germany.....	3,520,728	9,594,081	7,708,178	10,339,162	11,390,400
Netherlands.....	44,717,169	29,913,797	47,469,644	58,300,147	46,170,743
Roumania.....	42,307,170	26,247,144	31,514,810	67,658,882	1 <sup>1</sup> 67,658,882
Russia.....	85,270,647	54,050,456	189,272,459	225,458,494	144,795,697
Servia.....	1,932,494	3,319,493	5,296,155	2,669,180	3,366,243
United States.....	91,383,648	92,779,509	48,489,674	24,257,392	32,668,615
Other countries.....	10,600,009	6,042,808	11,267,187	15,940,830	2 <sup>1</sup> 16,801,727
Total.....	510,774,614	464,334,507	581,869,176	642,363,399	609,440,638

## IMPORTS.

Austria-Hungary.....	87,534	290,331	26,976,334	10,445,042	4,901,024
Belgium.....	67,468,698	67,031,906	70,921,646	75,219,303	82,191,689
Brazil.....	9,070,208	9,551,341	9,527,692	<sup>1</sup> 9,527,692	<sup>2</sup> 9,527,692
British South Africa.....	4,803,294	3,820,045	3,445,095	3,517,072	2,918,816
Denmark.....	2,820,271	3,593,737	3,496,826	2,823,854	3,059,944
France.....	13,131,119	2,752,388	5,248,539	23,326,840	<sup>2</sup> 78,755,778
Germany.....	90,199,206	76,813,536	39,400,124	86,116,905	91,429,660
Greece.....	7,454,387	6,638,757	6,490,139	7,659,686	7,934,138
Italy.....	27,391,457	24,214,665	43,023,688	45,259,960	43,300,144
Japan.....	2,008,998	1,319,524	778,524	1,818,229	2,019,164
Mexico.....	2,277,694	533,061	3,187,687	3,988,730	1 <sup>1</sup> 3,988,730
Netherlands.....	53,703,869	40,159,082	59,724,417	71,027,060	58,569,927
Portugal.....	962,457	4,603,995	3,898,434	3,024,080	1 <sup>1</sup> 3,024,080
Spain.....	4,290,631	2,902,210	3,529,873	5,932,747	6,764,525
Sweden.....	5,656,845	7,599,806	7,070,799	6,810,148	6,333,068
Switzerland.....	17,211,187	12,139,891	14,699,277	14,661,145	16,142,122
United Kingdom.....	180,443,017	168,629,046	182,219,770	195,965,191	182,352,177
Other countries.....	10,445,291	9,368,137	8,367,347	11,494,892	2 <sup>1</sup> 9,056,977
Total.....	499,426,163	441,961,458	542,006,211	578,618,576	612,269,655

<sup>1</sup> Year preceding.<sup>2</sup> Preliminary.<sup>3</sup> Data for 1909.

TABLE 27.—*International trade in wheat flour, calendar years 1907–1911.*

[See "General Note," page 564.]

## EXPORTS.

Country.	1907	1908	1909	1910	1911
	<i>Barrels.</i>	<i>Barrels.</i>	<i>Barrels.</i>	<i>Barrels.</i>	<i>Barrels.</i>
Argentina.....	1,434,104	1,276,643	1,310,241	1,298,104	1,332,726
Australia.....	1,667,722	1,191,861	1,326,216	1,428,019	1,794,805
Austria-Hungary.....	658,549	413,072	163,111	145,777	122,422
Belgium.....	442,299	529,655	583,822	718,100	750,100
British India.....	476,995	350,407	365,851	448,576	581,064
Bulgaria.....	298,506	287,039	348,572	581,360	755,907
Canada.....	1,858,485	1,747,163	2,541,849	3,189,208	3,542,124
Chile.....	50,736	32,030	72,073	128,593	69,215
France.....	299,244	365,492	493,116	283,297	1,192,539
Germany.....	987,594	1,702,896	1,855,560	2,137,285	1,820,238
Netherlands.....	159,968	145,450	292,223	267,489	190,584
Roumania.....	556,893	172,469	212,673	455,452	2,455,452
Russia.....	744,832	597,477	1,062,040	1,256,528	1,354,580
Serbia.....	33,570	62,997	53,027	113,816	80,184
United Kingdom.....	692,366	988,326	780,172	722,449	802,259
United States.....	15,276,506	13,013,025	9,687,993	8,370,201	11,255,030
Other countries.....	1,071,066	1,302,181	2,217,784	1,892,644	1,794,535
Total.....	26,704,435	24,178,183	23,366,323	23,436,898	26,896,764

## IMPORTS.

Belgium.....	48,735	31,734	23,211	29,365	47,409
Brazil.....	1,914,999	1,699,298	1,645,630	* 1,645,630	* 1,645,630
British Guiana.....	195,771	189,007	159,252	187,379	176,319
British South Africa.....	764,541	708,130	689,292	757,055	722,421
Canary Islands.....	109,698	111,173	106,968	* 106,968	* 106,968
China.....	3,002,982	1,194,514	405,971	503,973	1,486,063
Cuba.....	861,865	780,514	807,220	852,876	* 852,876
Denmark.....	384,264	441,511	515,921	549,230	599,172
Dutch East Indies.....	274,630	236,413	255,965	301,367	1,800,008
Egypt.....	1,582,371	1,919,747	1,916,444	1,367,797	1,813,225
Finland.....	963,964	1,022,019	964,691	999,454	1,123,140
France.....	197,243	81,823	49,118	140,751	* 155,405
Germany.....	221,299	190,880	141,292	166,857	172,035
Greece.....	60,923	24,953	12,711	9,379	14,490
Jamaica.....	248,435	223,361	200,960	232,117	243,053
Japan.....	838,641	352,537	172,165	203,337	200,301
Martinique.....	59,651	48,860	50,062	55,329	* 55,329
Netherlands.....	1,908,938	2,200,404	2,085,637	2,204,100	2,241,574
Newfoundland *.....	366,237	340,876	410,526	384,928	* 384,928
Norway.....	564,611	632,705	548,686	547,309	645,282
Philippine Islands.....	266,644	231,305	296,560	349,929	381,534
Singapore.....	272,781	256,937	273,976	230,401	* 230,401
Spain.....	695	172	630	867	668
Sweden.....	125,420	120,136	70,646	88,870	79,102
Switzerland.....	437,568	658,253	573,593	573,245	515,082
Trinidad and Tobago *.....	226,291	230,994	220,039	217,386	269,501
United Kingdom.....	7,565,526	7,358,072	6,282,145	5,614,907	5,681,535
Other countries.....	2,508,623	3,537,823	3,225,804	2,873,881	* 2,502,102
Total.....	25,973,346	24,824,151	22,105,115	21,194,687	23,144,553

1 Preliminary.

2 Year preceding.

3 Data for 1909.

4 Year beginning July 1.

Year beginning Apr. 1.

TABLE 28.—*International trade in wheat, including wheat flour, calendar years, 1907–1911.*

[In reducing wheat flour to terms of wheat, 1 barrel (196 pounds) has been taken as equivalent to the product from 4½ bushels of wheat. See "General note," p. 564.]

EXPORTS.

Country.	1907	1908	1909	1910	1911
	<i>Bushels.</i>	<i>Bushels.</i>	<i>Bushels.</i>	<i>Bushels.</i>	<i>Bushels.</i>
Argentina.....	104,955,069	139,354,456	98,273,601	75,050,917	89,990,727
Australia.....	36,288,879	20,390,762	37,517,470	54,187,981	63,224,462
Austria-Hungary.....	3,646,477	1,873,543	744,872	684,472	566,059
Belgium.....	19,842,362	26,561,682	25,472,143	26,129,374	26,098,800
British India.....	39,662,249	5,866,176	36,358,417	42,499,294	55,218,033
Bulgaria.....	10,166,192	9,109,936	7,481,195	11,304,193	14,523,577
Canada.....	45,866,239	60,365,137	60,866,515	60,777,308	76,413,578
Chile.....	1,526,064	5,090,943	4,339,663	2,825,589	802,729
France.....	1,394,449	1,863,487	2,896,235	1,324,326	1,893,851
Germany.....	7,964,901	17,257,113	16,058,198	19,956,944	19,581,471
Netherlands.....	45,437,025	30,568,322	48,784,648	59,503,847	47,028,371
Roumania.....	44,813,188	27,023,254	32,471,838	69,708,416	2,69,708,416
Russia.....	88,622,391	56,739,102	194,051,639	231,112,870	1,150,891,307
Servia.....	2,143,559	3,602,979	5,534,777	3,181,352	3,727,071
United Kingdom.....	3,600,114	5,026,976	3,950,066	4,448,078	4,611,991
United States.....	160,127,925	151,338,121	92,085,642	61,923,296	83,329,750
Other countries.....	14,887,487	11,104,338	20,130,711	23,211,180	1,23,847,884
Total.....	630,944,570	573,136,327	687,017,630	747,829,437	730,476,077

IMPORTS.

Austria-Hungary.....	130,320	332,928	27,162,972	10,616,726	5,149,680
Belgium.....	67,688,006	67,174,709	71,026,096	75,351,445	82,405,029
Brazil.....	17,687,704	17,198,182	16,933,027	16,933,027	16,933,027
British Guiana.....	880,970	850,531	716,634	843,206	793,436
British South Africa.....	8,243,728	7,006,630	6,546,909	6,923,820	6,169,711
Canary Islands.....	669,621	639,728	653,102	653,102	653,102
China.....	13,513,419	5,375,313	1,826,870	2,270,971	6,689,888
Cuba.....	3,878,392	3,512,313	3,632,490	3,837,942	3,837,942
Denmark.....	4,549,459	5,580,537	5,818,470	5,295,389	5,756,218
Dutch East Indies.....	1,236,133	1,064,397	1,152,302	1,356,706	1,360,649
Egypt.....	7,701,651	9,280,155	8,797,443	6,188,823	8,31,270
Finland.....	4,397,686	4,612,731	4,348,581	4,506,891	5,063,221
France.....	14,018,713	3,120,592	5,469,570	23,960,220	179,455,100
Germany.....	91,195,052	77,672,496	90,035,938	86,867,761	1,92,203,818
Greece.....	7,728,540	6,751,046	6,547,339	7,701,892	7,999,343
Italy.....	27,475,179	24,285,755	43,077,076	45,322,177	43,383,304
Jamaica.....	1,117,958	1,005,124	904,320	1,044,526	1,093,738
Japan.....	5,782,882	2,905,940	1,553,266	2,733,245	2,920,518
Martinique.....	268,434	219,873	225,287	248,980	248,980
Mexico.....	2,500,160	763,704	3,884,895	4,179,336	4,179,336
Netherlands.....	62,294,090	50,060,900	69,109,783	80,945,510	68,657,010
Newfoundland <sup>4</sup> .....	1,648,066	1,533,942	1,847,367	1,732,176	1,732,176
Norway.....	3,091,984	3,675,934	3,273,259	3,284,945	3,689,079
Philippine Islands.....	1,199,898	1,040,872	1,334,520	1,574,680	1,716,903
Portugal.....	962,457	4,603,995	3,898,434	3,024,080	3,024,080
Singapore.....	1,227,514	1,156,216	1,232,892	1,036,804	1,036,804
Spain.....	4,293,758	2,902,984	3,532,708	5,936,649	6,767,531
Sweden.....	6,221,235	8,140,418	7,988,706	7,210,063	6,689,027
Switzerland.....	19,180,243	15,102,029	17,280,445	17,240,747	18,459,991
Trinidad and Tobago <sup>5</sup> .....	1,018,510	1,039,473	990,176	978,237	1,212,754
United Kingdom.....	214,487,884	201,740,370	210,489,422	221,232,273	207,910,085
Other countries.....	20,016,774	23,310,321	21,288,930	22,962,316	1,18,748,350
Total.....	616,306,220	553,670,138	641,479,229	673,994,665	716,420,140

<sup>1</sup> Preliminary.

<sup>2</sup> Year preceding.

<sup>3</sup> Data for 1909.

<sup>4</sup> Year beginning July 1.

<sup>5</sup> Year beginning April 1



## OATS.

TABLE 29.—Oat area of countries named, 1908–1912.

Country.	1908	1909	1910	1911	1912
<b>NORTH AMERICA.</b>					
United States.....	<i>Acres.</i> 32,344,000	<i>Acres.</i> 35,159,000	<i>Acres.</i> 37,548,000	<i>Acres.</i> 37,763,000	<i>Acres.</i> 37,917,000
<b>Canada:</b>					
New Brunswick.....	203,900	207,200	213,900	198,500	186,000
Quebec.....	1,542,500	1,574,100	1,649,600	1,430,700	1,170,400
Ontario.....	3,108,400	3,142,200	3,272,000	2,734,100	2,637,000
Manitoba.....	1,322,800	1,390,000	1,451,000	1,260,700	1,269,000
Saskatchewan.....	930,100	1,847,000	1,973,000	2,124,100	2,285,600
Alberta.....	519,400	820,000	974,000	1,178,400	1,359,300
Other.....	284,000	322,100	330,600	307,000	309,600
Total Canada.....	7,911,100	9,302,600	9,864,100	9,233,500	9,216,900
Mexico.....	( <sup>1</sup> )	( <sup>1</sup> )	( <sup>1</sup> )	( <sup>1</sup> )	( <sup>1</sup> )
<b>SOUTH AMERICA.</b>					
Argentina.....	702,000	1,564,900	1,414,900	1,980,200	2,547,600
Chile.....	89,700	70,100	47,300	58,200	( <sup>1</sup> )
Uruguay.....	8,700	17,000	( <sup>1</sup> )	29,000	85,600
<b>EUROPE.</b>					
<b>Austria-Hungary:</b>					
Austria.....	4,495,600	4,574,400	4,529,400	4,640,700	4,613,200
Hungary proper.....	2,612,500	2,695,200	2,640,500	2,653,300	2,472,800
Croatia-Slavonia.....	246,800	246,900	243,400	247,500	239,300
Bosnia-Herzegovina.....	220,700	207,100	185,300	229,300	( <sup>1</sup> )
Total Austria-Hungary.....	7,575,600	7,723,600	7,598,600	7,770,800	.....
Belgium.....	630,100	618,300	( <sup>1</sup> )	( <sup>1</sup> )	( <sup>1</sup> )
Bulgaria.....	562,700	485,700	488,900	446,800	( <sup>1</sup> )
Denmark.....	* 996,000	( <sup>1</sup> )	( <sup>1</sup> )	( <sup>1</sup> )	( <sup>1</sup> )
Finland.....	( <sup>1</sup> )	( <sup>1</sup> )	( <sup>1</sup> )	( <sup>1</sup> )	( <sup>1</sup> )
France.....	9,628,700	9,702,500	9,763,700	9,863,000	9,877,200
Germany.....	10,564,400	10,649,900	10,599,100	10,693,700	10,841,300
Italy.....	( <sup>1</sup> )	1,243,700	1,243,700	1,270,500	1,254,300
Netherlands.....	345,500	349,700	348,400	341,500	338,500
Norway.....	* 264,300	( <sup>1</sup> )	( <sup>1</sup> )	( <sup>1</sup> )	( <sup>1</sup> )
Roumania.....	1,211,600	1,197,200	1,103,900	991,900	943,400
<b>Russia:</b>					
Russia proper.....	37,697,900	37,603,600	38,743,500	38,398,000	.....
Poland.....	2,794,900	2,813,900	2,858,700	2,894,400	.....
Northern Caucasia.....	1,107,100	1,122,400	1,299,200	1,310,800	.....
Total Russia (European).....	41,599,900	41,539,900	42,901,400	42,603,200	* 45,784,800
Servia.....	249,500	267,900	267,100	258,900	( <sup>1</sup> )
Spain.....	1,210,600	1,227,200	1,255,800	1,268,400	1,278,600
Sweden.....	1,998,300	1,994,100	1,970,600	1,951,700	( <sup>1</sup> )
<b>United Kingdom:</b>					
England.....	1,958,700	1,839,900	1,857,700	1,841,100	1,865,600
Wales.....	201,600	198,500	205,100	206,000	206,900
Scotland.....	948,500	943,400	958,200	963,500	956,600
Ireland.....	1,060,300	1,035,800	1,073,700	1,040,200	1,045,900
Total United Kingdom.....	4,169,100	4,017,600	4,094,700	4,050,800	4,075,000
<b>ASIA.</b>					
Cyprus.....	( <sup>1</sup> )	( <sup>1</sup> )	( <sup>1</sup> )	( <sup>1</sup> )	( <sup>1</sup> )
<b>Russia:</b>					
Central Asia.....	532,900	976,400	832,700	1,023,300	.....
Siberia.....	3,343,500	3,751,200	3,594,800	3,953,500	.....
Transcaucasia.....	1,200	1,400	2,600	1,900	.....
Total Russia (Asiatic).....	4,127,600	4,729,000	4,430,100	4,979,200	( <sup>4</sup> )
<b>AFRICA.</b>					
Algeria.....	340,700	425,200	404,600	434,100	475,600
Tunis.....	93,900	148,300	153,200	148,300	123,600
Union of South Africa.....	( <sup>1</sup> )	( <sup>1</sup> )	( <sup>1</sup> )	( <sup>1</sup> )	( <sup>1</sup> )

<sup>1</sup> No official statistics of area.<sup>2</sup> Area in 1907.<sup>3</sup> Includes Asiatic Russia (10 Governments of).<sup>4</sup> Included in European Russia.

TABLE 29.—Oat area of countries named, 1908–1912—Continued.

Country.	1908	1909	1910	1911	1912
AUSTRALASIA.					
<b>Australia:</b>	<i>Acres.</i>	<i>Acres.</i>	<i>Acres.</i>	<i>Acres.</i>	<i>Acres.</i>
Queensland.....	700	1,800	2,800	2,500	(1)
New South Wales.....	75,800	59,900	81,500	78,000	(1)
Victoria.....	398,700	419,900	384,200	392,700	(1)
South Australia.....	66,300	78,500	85,300	77,700	(1)
Western Australia.....	46,700	59,400	73,300	61,900	(1)
Tasmania.....	54,600	56,700	71,300	63,900	(1)
Total Australia.....	642,800	676,200	698,400	676,700	616,900
New Zealand.....	386,900	406,900	377,000	302,800	403,700
Total Australasia.....	1,029,700	1,083,100	1,075,400	979,500	1,020,600

1 No official statistics.

TABLE 30.—Oat crop of countries named, 1908–1912.

Country.	1908	1909	1910	1911	1912
NORTH AMERICA.					
<b>United States.....</b>	<i>Bushels.</i> 807,156,000	<i>Bushels.</i> 1,007,129,000	<i>Bushels.</i> 1,186,341,000	<i>Bushels.</i> 922,298,000	<i>Bushels.</i> 1,418,337,000
<b>Canada:</b>					
New Brunswick.....	5,057,000	5,775,000	6,351,000	5,727,000	5,359,000
Quebec.....	35,478,000	42,501,000	48,927,000	37,512,000	30,267,000
Ontario.....	103,821,000	109,192,000	128,917,000	82,679,000	91,899,000
Manitoba.....	44,711,000	55,267,000	41,742,000	87,893,000	53,806,000
Saskatchewan.....	29,205,000	91,796,000	61,367,000	97,962,000	105,115,000
Alberta.....	22,802,000	38,376,000	23,644,000	56,964,000	62,936,000
Other.....	9,303,000	10,559,000	12,501,000	9,849,000	12,351,000
Total Canada.....	250,377,000	353,466,000	323,449,000	348,586,000	361,733,000
Mexico.....	17,000	17,000	17,000	17,000	17,000
Total.....	1,057,550,000	1,360,612,000	1,509,807,000	1,270,901,000	1,780,087,000
SOUTH AMERICA.					
Argentina.....	33,949,000	31,984,000	36,483,000	47,192,000	69,169,000
Chile.....	1,817,000	2,373,000	2,611,000	1,861,000	2,000,000
Uruguay.....	239,000	462,000	400,000	590,000	1,825,000
Total.....	36,005,000	34,819,000	39,494,000	49,643,000	72,994,000
EUROPE.					
<b>Austria-Hungary:</b>					
Austria.....	144,069,000	148,825,000	126,548,000	135,143,000	146,376,000
Hungary proper.....	70,168,000	92,270,000	70,701,000	89,656,000	76,788,000
Croatia-Slavonia.....	4,253,000	5,607,000	5,445,000	6,442,000	3,311,000
Bosnia-Herzegovina.....	3,572,000	4,575,000	5,322,000	5,405,000	4,762,000
Total Austria-Hungary.....	222,062,000	251,277,000	208,016,000	236,646,000	231,217,000
Belgium.....	43,058,000	43,231,000	35,000,000	40,000,000	38,000,000
Bulgaria.....	11,252,000	9,356,000	10,789,000	12,000,000	11,500,000
Denmark.....	40,437,000	42,170,000	40,596,000	41,188,000	42,400,000
Finland.....	18,321,000	19,759,000	18,000,000	22,642,000	26,618,000
France.....	285,837,000	331,183,000	290,776,000	303,328,000	328,601,000
Germany.....	530,126,000	628,712,000	544,287,000	530,764,000	586,987,000
Italy.....	30,000,000	43,402,000	28,574,000	40,973,000	28,306,000
Netherlands.....	19,683,000	19,361,000	18,039,000	17,724,000	16,000,000
Norway.....	11,315,000	8,804,000	10,488,000	8,593,000	11,607,000
Roumania.....	17,212,000	25,945,000	29,647,000	26,222,000	20,775,000
Russia:					
Russia proper.....	743,523,000	960,438,000	869,736,000	690,753,000	.....
Poland.....	63,135,000	73,758,000	65,510,000	78,465,000	.....
Northern Caucasia.....	24,860,000	33,428,000	31,022,000	23,681,000	.....
Total Russia (European).....	834,518,000	1,067,684,000	966,248,000	792,899,000	972,111,000
Sarvia.....	3,057,000	5,810,000	5,364,000	5,050,000	4,750,000
Spain.....	28,114,000	34,307,000	29,018,000	33,858,000	23,035,000
Sweden.....	72,773,000	69,292,000	75,238,000	63,462,000	75,900,000
<b>United Kingdom:</b>					
England.....	82,470,000	80,573,000	80,225,000	74,119,000	68,708,000
Wales.....	7,133,000	7,233,000	8,018,000	7,087,000	7,040,000
Scotland.....	37,920,000	39,097,000	37,425,000	36,757,000	37,600,000
Ireland.....	54,032,000	57,467,000	65,770,000	59,207,000	66,867,000
Total United Kingdom.....	181,555,000	184,370,000	191,438,000	177,170,000	180,215,000
Total.....	2,349,320,000	2,784,663,000	2,501,518,000	2,352,519,000	2,598,022,000

TABLE 30.—*Oat crop of countries named, 1908-1912—Continued.*

Country.	1908	1909	1910	1911	1912
	<i>Bushels.</i>	<i>Bushels.</i>	<i>Bushels.</i>	<i>Bushels.</i>	<i>Bushels.</i> <sup>a</sup>
Cyprus.....	382,000	385,000	515,000	466,000	500,000
<b>Russia:</b>					
Central Asia.....	17,371,000	15,633,000	12,812,000	12,972,000	.....
Siberia.....	89,500,000	62,033,000	66,874,000	53,272,000	.....
Transcaucasia.....	27,000	37,000	57,000	37,000	.....
Total Russia (Asiatic).....	106,898,000	77,703,000	79,743,000	66,281,000	95,473,000
Total.....	107,280,000	78,088,000	80,258,000	66,747,000	95,973,000
<b>AFRICA.</b>					
Algeria.....	10,651,000	9,600,000	13,306,000	11,520,000	12,287,000
Tunis.....	1,736,000	5,443,000	5,374,000	4,650,000	2,067,000
Union of South Africa.....	3,500,000	3,500,000	3,500,000	3,500,000	3,500,000
Total.....	15,887,000	18,543,000	22,180,000	19,670,000	17,854,000
<b>AUSTRALASIA.</b>					
<b>Australia:</b>					
Queensland.....	10,000	40,000	52,000	52,000	6,000
New South Wales.....	879,000	1,154,000	2,029,000	1,756,000	1,192,000
Victoria.....	5,365,000	11,475,000	8,163,000	10,005,000	4,730,000
South Australia.....	902,000	1,320,000	1,247,000	1,172,000	1,392,000
Western Australia.....	745,000	765,000	1,287,000	801,000	991,000
Tasmania.....	1,574,000	1,900,000	2,422,000	2,128,000	1,552,000
Total Australia.....	9,475,000	16,654,000	15,200,000	15,914,000	9,863,000
New Zealand.....	15,495,000	19,503,000	13,953,000	10,412,000	10,438,000
Total Australasia.....	24,970,000	36,157,000	29,153,000	26,326,000	20,301,000
Grand total.....	3,591,012,000	4,312,882,000	4,182,410,000	3,785,806,000	4,585,231,000

TABLE 31.—*Total production of oats in countries named in Table 30, 1895-1912.*

Year.	Production.	Year.	Production.	Year.	Production.	Year.	Production.
	<i>Bushels.</i>		<i>Bushels.</i>		<i>Bushels.</i>		<i>Bushels.</i>
1895.....	3,008,154,000	1900.....	3,106,002,000	1905.....	3,510,167,000	1910.....	4,182,410,000
1896.....	2,847,115,000	1901.....	2,862,615,000	1906.....	3,544,961,000	1911.....	3,785,806,000
1897.....	2,633,971,000	1902.....	3,626,303,000	1907.....	3,603,896,000	1912.....	4,585,231,000
1898.....	2,903,974,000	1903.....	3,378,034,000	1908.....	3,591,012,000		
1899.....	3,256,256,000	1904.....	3,611,302,000	1909.....	4,312,882,000		

TABLE 32.—*Average yield of oats in countries named, bushels per acre, 1890-1912.*

Year.	United States.	Russia, Euro-pean. <sup>1</sup>	Ger-many. <sup>1</sup>	Austria. <sup>1</sup>	Hungary proper. <sup>1</sup>	Franco. <sup>2</sup>	United King-dom. <sup>2</sup>
Average (1890-1899).....	26.1	17.8	40.0	25.3	.....	29.8	43.6
Average (1900-1909).....	29.3	20.0	50.7	29.8	30.7	31.6	44.3
1903.....	28.4	17.7	51.2	28.3	34.5	31.6	44.2
1904.....	32.1	25.7	46.2	24.3	25.6	27.2	44.2
1905.....	34.0	20.2	43.6	27.7	31.0	28.6	41.7
1906.....	31.2	15.1	55.7	34.1	34.2	27.0	43.8
1907.....	23.7	19.7	58.3	35.7	30.0	31.8	45.1
1908.....	25.0	20.1	50.2	32.0	26.8	29.6	43.5
1909.....	28.6	25.7	59.0	37.6	33.8	34.1	45.3
1910.....	31.6	18.1	51.4	31.4	26.8	29.8	46.8
1911.....	24.4	<sup>a</sup> 18.0	49.6	23.7	34.0	30.5	43.7
1912.....	37.4	<sup>a</sup> 23.3	54.1	36.3	31.2	27.3	44.2
Average (1903-1912).....	29.6	20.4	51.9	31.1	30.8	29.8	44.3

<sup>1</sup> Bushels of 32 pounds.<sup>2</sup> Winchester bushels.<sup>3</sup> Includes Asiatic Russia.

TABLE 33.—*Acreage, production, value, exports, etc., of oats, United States, 1849-1912.*

Year.	Acreage sown and harvested.		Average yield per acre.	Production.	Average farm price per bushel Dec. 1.	Farm value Dec. 1.	Chicago cash price per bushel, No. 2. <sup>1</sup>				Domestic exports, including oatmeal, fiscal year beginning July 1. <sup>2</sup>	Imports during fiscal year beginning July 1. <sup>3</sup>
							December.		May of following year.			
	Low.	High.					Low.	High.				
1849 <sup>4</sup> .....				146,584,000								
1850 <sup>4</sup> .....				172,643,000								
1856 .....	8,864,000	30.2	268,141,000	35.1	94,058,000	36	43	59	78	122,595	778,193	
1857 .....	10,746,000	25.9	278,698,000	44.5	123,903,000	52	57			825,854	780,798	
1858 .....	9,666,000	26.4	254,961,000	41.7	106,356,000	43	49	56	62	481,871	326,659	
1859 .....	9,461,000	30.5	288,334,000	38.0	109,522,000	40	44	46	53	121,517	2,266,785	
1869 <sup>4</sup> .....			282,107,000									
1870 .....	8,792,000	28.1	247,277,000	39.0	96,444,000	37	41	47	51	147,572	599,514	
1871 .....	8,366,000	30.6	255,743,000	36.2	92,591,000	30	33	34	42	262,975	535,250	
1872 .....	9,001,000	30.2	271,747,000	29.9	81,304,000	23	25	30	34	714,072	225,555	
1873 .....	9,752,000	27.7	270,340,000	34.6	93,474,000	34	40	44	48	812,873	191,802	
1874 .....	10,897,000	22.1	240,369,000	47.1	113,134,000	51	54	57	64	502,770	1,500,040	
1875 .....	11,915,000	29.7	354,318,000	32.0	113,441,000	29	30	28	31	1,466,228	121,547	
1876 .....	13,359,000	24.0	320,884,000	32.4	103,845,000	31	34	37	45	2,854,128	41,597	
1877 .....	12,826,000	31.7	406,394,000	28.4	115,546,000	24	27	23	27	3,715,479	21,391	
1878 .....	13,176,000	31.4	413,579,000	24.6	101,752,000	19	20	24	30	5,452,136	13,395	
1879 .....	12,684,000	28.7	363,761,000	33.1	120,533,000	32	36	29	34	766,366	489,576	
1879 <sup>4</sup> .....	16,145,000	25.8	407,859,000									
1880 .....	16,188,000	25.8	417,885,000	36.0	150,244,000	29	33	36	39	402,904	64,412	
1881 .....	16,832,000	24.7	416,481,000	46.4	193,199,000	43	46	48	56	625,690	1,850,983	
1882 .....	18,495,000	26.4	488,251,000	37.5	182,978,000	34	41	38	42	461,496	815,017	
1883 .....	20,325,000	28.1	571,302,000	32.7	187,040,000	29	36	50	34	3,274,622	121,069	
1884 .....	21,301,000	27.4	583,628,000	27.7	161,528,000	22	25	34	37	6,203,104	94,310	
1885 .....	22,784,000	27.6	629,409,000	25.5	179,632,000	27	29	26	29	7,311,306	149,480	
1886 .....	23,658,000	26.4	624,434,000	29.8	186,138,000	25	27	25	28	1,374,635	139,575	
1887 .....	25,921,000	25.4	659,618,000	30.4	200,700,000	28	30	32	38	573,080	123,817	
1888 .....	26,998,000	26.0	701,735,000	27.8	195,424,000	25	26	21	23	1,191,471	131,501	
1889 .....	27,462,000	27.4	751,515,000	22.9	171,781,000	20	21	24	30	15,107,238	153,232	
1889 <sup>4</sup> .....	28,321,000	28.6	809,251,000									
1890 .....	26,431,000	19.8	523,621,000	42.4	222,048,000	39	43	45	54	1,382,836	41,848	
1891 .....	25,582,000	28.9	738,394,000	31.5	232,312,000	31	33	28	33	10,586,644	47,782	
1892 .....	27,064,000	24.4	661,035,000	31.7	209,254,000	25	31	28	32	2,700,793	49,433	
1893 .....	27,273,000	23.4	638,855,000	29.4	187,576,000	27	29	32	30	6,290,229	31,759	
1894 .....	27,024,000	24.5	662,037,000	32.4	214,817,000	28	29	27	30	1,708,824	330,318	
1895 .....	27,878,000	29.6	824,444,000	19.9	163,655,000	16	17	18	19	15,156,518	66,602	
1896 .....	27,566,000	25.7	707,346,000	18.7	132,485,000	16	18	16	18	37,725,083	131,204	
1897 .....	25,730,000	27.2	698,768,000	21.2	147,975,000	21	23	26	32	73,880,307	25,093	
1898 .....	25,777,000	28.4	730,907,000	25.5	186,405,000	26	27	24	27	33,534,362	28,098	
1899 .....	26,341,000	30.2	796,178,000	24.9	198,168,000	22	23	21	23	45,048,857	54,576	
1899 <sup>4</sup> .....	29,540,000	31.9	943,389,000									
1900 .....	27,365,000	29.6	809,126,000	25.8	208,669,000	21	22	27	31	42,268,931	32,107	
1901 .....	28,541,000	25.8	736,809,000	39.9	293,650,000	42	48	41	45	13,277,612	38,978	
1902 .....	28,653,000	34.5	987,843,000	30.7	503,585,000	29	32	33	38	8,381,805	150,065	
1903 .....	27,638,000	28.4	784,094,000	34.1	287,662,000	34	38	39	44	1,930,740	183,983	
1904 .....	27,843,000	32.1	894,596,000	31.3	279,900,000	28	32	28	32	8,394,692	55,699	
1905 .....	28,047,000	34.0	953,216,000	29.1	277,048,000	29	32	32	34	48,434,541	40,025	
1906 .....	30,959,000	31.2	964,905,000	31.7	306,293,000	33	35	44	48	6,386,334	91,289	
1907 .....	31,837,000	23.7	754,443,000	44.3	334,568,000	46	50	52	56	2,518,855	383,418	
1908 .....	32,344,000	25.0	807,156,000	47.2	381,171,000	48	50	56	62	2,333,740	6,691,700	
1909 .....	33,204,000	30.3	1,007,353,000	40.5	408,174,000	48	45	36	43	2,548,726	1,034,511	
1909 <sup>4</sup> .....	35,159,000	23.4	1,007,129,000									
1910 <sup>5</sup> .....	37,548,000	31.6	1,186,341,000	34.4	408,388,000	31	32	31	36	3,845,850	107,318	
1911 <sup>5</sup> .....	37,763,000	24.4	922,298,000	45.0	414,663,000	46	47	50	58	2,677,749	2,622,357	
1912 .....	37,917,000	37.4	1,418,337,000	31.9	432,469,000	31	31					

<sup>1</sup> Quotations are for standard since 1905.

<sup>2</sup> Oatmeal not included 1866 to 1882, inclusive.

<sup>3</sup> Oatmeal not included 1867 to 1882, inclusive, and 1909.

<sup>4</sup> Census figures.

<sup>5</sup> Figures adjusted to census basis.

TABLE 34.—Acreage and production of oats, by States, 1909–1912.

State and division.	Acreage (000 omitted).				Production (000 omitted).			
	1912	1911	1910	1909 (census).	1912	1911	1910	1909 (census).
	Acres.	Acres.	Acres.	Acres.	Bush.	Bush.	Bush.	Bush.
Maine.....	133	135	130	121	4,602	5,198	5,512	4,232
New Hampshire.....	12	12	11	11	468	406	471	386
Vermont.....	77	76	76	72	3,311	2,660	3,154	2,141
Massachusetts.....	8	8	8	8	272	280	284	268
Rhode Island.....	2	2	2	2	57	58	70	48
Connecticut.....	11	11	11	10	338	386	405	274
New York.....	1,192	1,310	1,320	1,303	36,714	38,645	45,540	34,795
New Jersey.....	67	71	72	72	1,849	2,024	2,671	1,377
Pennsylvania.....	1,099	1,121	1,144	1,144	36,377	31,724	40,269	28,173
North Atlantic.....	2,601	2,746	2,774	2,743	83,988	81,381	98,376	71,694
Delaware.....	4	4	4	4	122	120	135	98
Maryland.....	45	46	47	49	1,350	1,242	1,410	1,161
Virginia.....	175	194	198	204	3,885	3,880	4,356	2,884
West Virginia.....	111	110	110	104	3,108	2,420	2,772	1,729
North Carolina.....	204	219	221	228	3,794	3,614	4,022	2,782
South Carolina.....	324	345	336	324	6,966	7,038	7,056	5,745
Georgia.....	364	404	404	412	7,571	8,686	7,353	6,199
Florida.....	43	43	42	43	740	580	680	606
South Atlantic.....	1,270	1,365	1,362	1,368	27,536	27,580	27,704	21,204
Ohio.....	2,120	1,700	1,770	1,788	93,280	54,570	65,844	57,591
Indiana.....	1,990	1,640	1,680	1,668	79,799	47,068	59,472	50,608
Illinois.....	4,220	4,220	4,325	4,177	182,726	121,536	164,350	150,386
Michigan.....	1,485	1,500	1,515	1,429	51,826	42,900	51,510	43,870
Wisconsin.....	2,272	2,250	2,250	2,164	84,746	67,050	67,050	71,336
North Central, East of Mississippi River.....	12,087	11,310	11,540	11,226	492,377	333,124	408,226	373,791
Minnesota.....	2,948	2,948	2,977	2,977	122,932	67,214	85,440	93,898
Iowa.....	4,928	4,950	5,100	4,655	217,818	126,225	192,780	128,198
Missouri.....	1,125	1,200	1,200	1,073	37,125	17,760	40,320	24,829
North Dakota.....	2,300	2,180	2,165	2,147	95,220	51,230	15,155	65,887
South Dakota.....	1,550	1,540	1,550	1,559	52,390	11,896	35,650	43,566
Nebraska.....	2,275	2,500	2,532	2,366	55,510	34,750	70,896	53,300
Kansas.....	1,720	2,000	1,675	933	55,040	30,000	55,778	22,924
North Central, West of Mississippi River.....	16,846	17,318	17,199	15,710	636,035	338,575	496,019	432,662
Kentucky.....	150	170	175	174	4,035	3,128	4,375	2,406
Tennessee.....	258	315	342	342	5,599	6,142	7,866	4,721
Alabama.....	260	283	283	257	5,200	5,434	5,236	3,251
Mississippi.....	113	130	120	97	1,966	2,392	2,304	1,269
Louisiana.....	34	40	36	30	707	840	774	420
Texas.....	865	737	688	440	31,140	18,499	24,080	7,035
Oklahoma.....	936	909	699	609	23,494	8,181	25,514	16,606
Arkansas.....	175	205	207	197	3,482	4,100	5,692	3,213
South Central.....	2,791	2,789	2,550	2,146	75,623	48,716	75,841	38,921
Montana.....	476	425	390	333	22,848	21,165	14,520	13,806
Wyoming.....	205	190	161	124	8,569	6,555	5,152	3,161
Colorado.....	290	290	284	276	12,412	10,150	11,104	7,643
New Mexico.....	53	48	42	34	1,839	1,862	1,151	721
Arizona.....	6	6	5	6	268	252	200	189
Utah.....	91	87	85	81	4,222	3,889	3,655	3,221
Nevada.....	10	8	7	8	400	360	313	335
Idaho.....	348	331	319	303	17,017	14,564	12,282	11,328
Washington.....	284	281	275	270	13,689	14,528	11,770	13,228
Oregon.....	359	359	355	339	13,714	12,457	12,243	10,881
California.....	200	210	200	192	7,800	7,140	7,400	4,144
Far Western.....	2,322	2,235	2,123	1,966	102,778	92,922	80,095	68,857
United States.....	37,917	37,763	37,548	35,159	1,418,337	922,298	1,186,341	1,007,129

TABLE 35.—Total farm value and value per acre of oats, by States, 1909–1912.

State and division.	Value, basis Dec. 1 price (000 omitted).				Value per acre, basis Dec. 1 price.			
	1912	1911	1910	1909	1912	1911	1910	1909
	Dolls.	Dolls.	Dolls.	Dolls.	Dolls.	Dolls.	Dolls.	Dolls.
<b>Maine</b> .....	2,347	2,807	2,646	2,455	17.65	20.79	20.35	20.30
<b>New Hampshire</b> .....	225	248	240	247	18.72	20.62	21.83	22.78
<b>Vermont</b> .....	1,589	1,569	1,577	1,071	20.64	20.65	20.75	14.95
<b>Massachusetts</b> .....	128	162	142	156	15.98	20.30	17.75	19.14
<b>Rhode Island</b> .....	26	34	34	26	12.87	16.82	16.80	14.79
<b>Connecticut</b> .....	166	216	178	145	15.04	19.66	16.19	14.20
<b>New York</b> .....	15,420	19,709	19,127	17,050	12.94	15.04	14.49	13.08
<b>New Jersey</b> .....	814	1,012	1,175	688	12.14	14.25	16.32	9.55
<b>Pennsylvania</b> .....	14,915	15,862	16,510	14,086	13.57	14.15	14.43	12.30
<b>North Atlantic</b> .....	35,630	41,619	41,629	35,924	13.70	15.16	15.01	13.10
<b>Delaware</b> .....	55	56	58	47	13.72	14.10	14.53	11.14
<b>Maryland</b> .....	608	609	649	569	13.50	13.23	13.80	11.56
<b>Virginia</b> .....	2,020	2,095	2,134	1,558	11.54	10.80	10.78	7.61
<b>West Virginia</b> .....	1,461	1,355	1,386	934	13.16	12.32	12.60	9.02
<b>North Carolina</b> .....	2,352	2,277	2,413	1,836	11.53	10.40	10.92	8.05
<b>South Carolina</b> .....	4,598	5,067	4,586	4,137	14.19	14.69	13.65	12.74
<b>Georgia</b> .....	4,921	6,080	4,706	4,401	13.52	15.05	11.65	10.72
<b>Florida</b> .....	518	435	442	455	12.04	10.12	10.53	10.50
<b>South Atlantic</b> .....	16,533	17,974	16,374	13,937	13.02	13.17	12.02	10.19
<b>Ohio</b> .....	30,782	24,556	23,045	23,612	14.52	14.44	13.02	13.24
<b>Indiana</b> .....	23,940	20,239	18,436	19,737	12.03	12.34	10.97	11.82
<b>Illinois</b> .....	54,818	51,045	49,305	57,147	12.99	12.10	11.40	10.72
<b>Michigan</b> .....	17,103	19,734	18,028	17,986	11.52	13.16	11.90	12.59
<b>Wisconsin</b> .....	27,119	30,172	22,797	27,821	11.94	13.41	10.13	12.83
<b>North Central, East of Mississippi River</b> .....	153,762	145,746	131,611	146,303	12.72	12.89	11.40	13.03
<b>Minnesota</b> .....	31,962	26,886	27,341	32,864	10.84	9.12	9.18	11.02
<b>Iowa</b> .....	58,811	51,752	52,051	44,869	11.93	10.46	10.21	9.66
<b>Missouri</b> .....	12,994	7,992	12,902	10,676	11.55	6.66	10.75	9.93
<b>North Dakota</b> .....	20,948	21,004	5,607	21,743	9.11	9.64	2.59	10.13
<b>South Dakota</b> .....	13,098	4,900	10,695	14,812	8.45	3.18	6.90	9.49
<b>Nebraska</b> .....	16,653	14,942	19,851	18,676	7.32	5.98	7.84	7.91
<b>Kansas</b> .....	19,264	13,500	18,965	9,857	11.20	6.75	11.32	10.58
<b>North Central, West of Mississippi River</b> .....	173,730	140,976	147,412	153,497	10.31	8.14	8.57	9.77
<b>Kentucky</b> .....	1,775	1,564	1,969	1,227	11.84	9.20	11.25	7.04
<b>Tennessee</b> .....	2,632	3,071	3,618	2,502	10.20	9.75	10.58	7.31
<b>Alabama</b> .....	3,224	3,586	3,142	2,276	12.40	12.67	11.10	8.82
<b>Mississippi</b> .....	1,180	1,555	1,267	863	10.44	11.96	10.56	8.91
<b>Louisiana</b> .....	361	546	379	260	10.61	13.65	10.54	8.74
<b>Texas</b> .....	13,390	9,989	11,318	4,361	15.48	13.55	16.45	9.92
<b>Oklahoma</b> .....	7,988	3,927	9,440	7,639	8.53	4.32	13.50	12.56
<b>Arkansas</b> .....	1,741	2,173	2,618	1,896	9.95	10.60	12.65	9.62
<b>South Central</b> .....	32,291	26,411	33,751	21,024	11.57	9.47	13.24	9.80
<b>Montana</b> .....	7,997	8,466	6,817	5,798	16.80	19.92	17.48	17.29
<b>Wyoming</b> .....	3,171	3,278	2,576	1,681	15.47	17.25	16.00	13.55
<b>Colorado</b> .....	4,717	4,872	5,108	4,051	16.26	16.80	17.99	14.68
<b>New Mexico</b> .....	828	1,061	714	476	15.62	22.12	16.99	12.52
<b>Arizona</b> .....	188	151	180	150	31.29	25.20	36.09	25.52
<b>Utah</b> .....	2,039	1,828	1,754	1,675	22.74	21.01	20.64	20.75
<b>Nevada</b> .....	298	223	197	193	20.80	27.90	28.16	25.19
<b>Idaho</b> .....	5,956	5,826	5,152	5,664	17.12	17.60	16.17	18.70
<b>Washington</b> .....	8,473	6,538	5,650	6,349	19.28	23.26	26.54	23.52
<b>Oregon</b> .....	5,623	5,481	5,757	5,658	15.66	15.27	16.22	16.69
<b>California</b> .....	4,290	4,213	3,700	2,735	21.45	20.06	18.50	14.26
<b>Far Western</b> .....	40,523	41,927	37,611	34,435	17.45	18.76	17.72	17.52
<b>United States</b> .....	452,469	414,653	408,388	405,120	11.93	10.98	10.88	11.52

TABLE 36.—Yield per acre and price per bushel of oats, by States.

State and division.	Yield per acre.						Farm price per bushel Dec. 1.										
	10-year averages.						10-year averages for Dec. 1.					Dec. 1, 1910.	Dec. 1, 1911.	Quarterly, 1912.			
	1870-1879	1880-1889	1890-1899	1900-1909	1910	1911	1912	1870-1879	1880-1889	1890-1899	1900-1909			Mar. 1.	June 1.	Sept. 1.	Dec. 1.
	Bu.	Bu.	Bu.	Bu.	Bu.	Bu.	Bu.	Cts.	Cts.	Cts.	Cts.	Cts.	Cts.	Cts.	Cts.	Cts.	
Maine.....	26.0	28.2	34.7	37.0	42.4	38.5	34.6	49	44	40	49	45	54	60	72	60	51
N. H.....	36.0	32.3	34.0	32.3	42.8	33.8	39.0	50	46	42	50	51	61	61	67	59	48
Vermont....	35.4	33.1	36.0	36.0	41.5	35.0	43.0	44	42	40	48	50	59	62	71	59	48
Mass.....	31.9	29.9	32.8	33.1	35.5	35.0	34.0	53	48	41	50	50	58	63	73	70	47
R. I.....	30.7	28.0	29.0	29.4	35.0	29.0	28.6	51	49	42	50	48	58	64	70	40	45
Conn.....	29.9	28.1	27.2	31.9	36.8	35.1	30.7	53	46	40	47	44	56	61	67	65	49
New York...	32.9	28.6	27.8	31.3	34.5	29.5	30.8	41	39	34	43	42	51	56	64	48	42
N. J.....	28.8	26.8	26.3	28.0	37.1	28.5	27.6	42	39	36	44	44	50	55	65	57	44
Pa.....	30.8	28.1	26.6	29.3	35.2	28.3	33.1	38	37	34	42	41	50	56	65	46	41
N. Atlan- tic.....	31.6	28.5	28.0	30.8	35.5	29.6	32.3	40.4	38.8	34.7	43.2	42.3	51.1	56.4	65.2	48.6	42.4
Delaware...	21.5	21.0	20.9	25.4	33.8	30.0	30.5	37	37	32	43	43	47	50	60	45	45
Maryland...	19.8	20.1	20.9	25.1	30.0	27.0	30.0	38	37	33	41	46	49	51	60	49	45
Virginia....	15.1	11.8	14.0	17.6	22.0	20.0	22.2	40	41	34	45	49	54	62	66	52	52
W. Va.....	23.6	17.7	20.7	22.1	25.2	22.0	28.0	35	37	36	45	50	56	59	66	55	47
N. C.....	14.4	9.5	12.0	14.8	18.2	16.5	18.6	52	49	42	54	60	63	65	73	64	62
S. C.....	12.0	10.5	12.6	17.1	21.0	20.4	21.5	72	61	51	62	65	72	71	77	68	66
Georgia....	12.9	9.8	12.5	15.3	18.2	21.5	20.8	68	60	50	60	64	70	73	75	71	65
Florida....	13.4	10.2	11.1	13.5	16.2	13.5	17.2	88	70	57	64	65	75	79	80	80	70
S. Atlan- tic.....	15.6	11.3	13.6	16.9	20.4	20.2	21.7	47.8	49.3	42.2	53.7	58.9	65.2	68.2	72.9	64.9	60.0
Ohio.....	29.5	30.7	29.7	33.2	37.2	32.1	44.0	30	33	28	36	35	45	50	56	33	33
Indiana....	26.1	27.2	27.3	29.0	35.4	28.7	40.1	28	30	27	34	31	43	48	53	30	30
Illinois....	30.1	34.2	29.6	31.2	38.0	28.8	43.3	25	27	25	34	30	42	48	52	30	30
Michigan...	32.4	32.3	28.7	31.6	34.0	28.6	34.9	34	33	30	37	35	46	50	58	35	33
Wisconsin..	34.6	30.4	32.8	33.3	29.8	29.8	37.3	29	30	26	34	34	45	49	54	35	32
N. C. E. Miss. R.	30.2	31.9	29.9	31.0	35.4	29.5	40.7	28.3	29.2	26.2	34.6	32.2	43.8	48.8	54.0	32.1	31.2
Minnesota.	34.0	33.4	31.0	31.7	28.7	22.8	41.7	29	27	24	31	32	40	45	48	25	26
Iowa.....	34.4	32.2	31.2	29.5	37.8	25.5	44.2	22	24	23	30	27	41	45	48	26	27
Missouri...	27.6	26.1	21.9	23.4	33.6	14.8	33.0	26	28	25	35	32	45	51	54	33	35
N. Dak.....	.....	30.7	26.7	29.7	7.0	23.5	41.4	.....	28	26	31	37	41	44	52	30	22
S. Dak.....	.....	30.7	23.6	31.6	23.0	7.4	33.8	.....	28	23	30	30	43	49	52	25	25
Nebraska...	32.2	28.5	24.4	26.4	28.0	13.9	24.4	23	22	23	30	28	43	47	50	30	30
Kansas....	31.7	28.0	22.4	24.4	33.3	15.0	32.0	25	26	24	35	34	45	51	57	39	35
N. C. W. Miss. R.	32.0	30.1	27.1	28.8	28.8	19.6	37.8	24.6	25.4	23.3	30.8	29.7	41.6	46.0	50.1	28.3	27.3
Kentucky..	22.2	18.2	19.4	20.9	25.0	18.4	26.9	37	36	33	42	45	50	59	69	48	44
Tennessee.	18.4	13.6	15.2	19.4	23.0	19.5	21.7	39	39	33	44	46	50	60	66	48	47
Alabama...	14.2	10.7	13.1	15.6	18.5	19.2	20.0	69	60	48	58	60	66	73	78	70	62
Mississippi.	15.0	11.2	13.5	16.7	19.2	18.4	17.4	77	60	48	56	55	65	68	76	66	60
Louisiana..	16.8	12.7	15.4	16.9	21.5	21.0	20.8	85	57	44	51	49	65	62	65	55	51
Texas.....	23.7	23.8	24.4	27.8	35.0	25.1	36.0	67	44	37	48	47	54	68	69	38	43
Oklahoma..	.....	.....	29.4	36.5	9.0	25.1	.....	.....	.....	38	37	48	63	66	66	36	34
Arkansas...	23.3	16.7	18.4	20.0	27.5	20.0	19.9	54	42	37	47	46	53	64	73	54	50
S. Central.	20.4	16.0	18.4	23.9	29.7	17.5	27.1	45.6	44.9	37.1	43.8	44.5	54.2	65.7	69.6	45.7	42.7
Montana...	.....	33.6	36.3	43.3	38.0	49.8	48.0	.....	48	40	42	46	40	47	56	43	35
Wyoming...	.....	29.7	31.5	35.9	32.0	34.5	41.8	.....	47	42	47	50	50	60	68	52	37
Colorado...	32.4	30.8	28.6	35.3	39.1	35.0	42.8	67	53	38	47	46	48	47	60	40	38
N. Mex.....	.....	22.3	29.6	29.9	27.4	38.8	34.7	.....	50	48	59	62	57	60	69	50	45
Arizona....	.....	.....	33.3	40.1	42.0	44.7	.....	.....	.....	68	90	60	.....	.....	.....	82	70
Utah.....	.....	26.2	32.4	40.2	43.0	44.7	46.4	.....	44	38	48	48	47	51	66	50	49
Novada....	33.9	29.8	.....	38.6	44.7	45.0	40.0	90	62	.....	65	63	62	55	63	73	52
Idaho.....	.....	31.3	35.3	41.7	38.5	44.0	48.9	.....	49	38	45	42	40	45	52	37	35
Wash.....	.....	36.4	30.2	46.3	42.8	51.7	48.2	.....	42	37	43	48	45	45	60	45	40
Oregon....	34.3	28.2	30.1	30.0	34.5	34.7	38.2	50	42	37	44	47	44	45	54	39	41
California.	32.1	26.2	28.8	31.2	37.0	34.0	39.0	71	53	47	56	50	59	55	61	49	55
Far West- ern.....	32.8	29.3	31.6	36.9	37.7	41.6	44.3	62.5	46.4	38.6	45.7	47.0	45.1	47.5	58.4	43.5	39.4
U. S.....	28.4	26.5	26.2	29.5	31.6	24.4	37.4	33.7	32.0	27.8	35.5	34.4	45.0	49.8	55.3	35.0	31.9

<sup>1</sup> The Territories.

TABLE 37.—Farm price of oats per bushel on first of each month, 1911-1912.

Month.	United States.		North Atlantic States.		South Atlantic States.		N. Central States east of Miss. R.		N. Central States west of Miss. R.		South Central States.		Far Western States.	
	1912	1911	1912	1911	1912	1911	1912	1911	1912	1911	1912	1911	1912	1911
	<i>Cts.</i>	<i>Cts.</i>	<i>Cts.</i>	<i>Cts.</i>	<i>Cts.</i>	<i>Cts.</i>	<i>Cts.</i>	<i>Cts.</i>	<i>Cts.</i>	<i>Cts.</i>	<i>Cts.</i>	<i>Cts.</i>	<i>Cts.</i>	<i>Cts.</i>
January.....	45.1	33.2	51.5	41.5	64.7	58.5	44.2	31.1	41.6	28.9	55.5	45.3	44.5	42.0
February.....	47.5	33.1	53.2	41.3	67.5	58.9	46.2	31.4	44.3	28.3	62.5	45.7	44.6	42.9
March.....	49.8	32.8	56.4	40.4	68.2	57.8	48.8	30.7	46.0	28.5	65.7	45.2	47.5	43.6
April.....	52.0	32.3	58.8	40.8	69.1	57.5	50.8	30.5	48.7	27.6	66.7	44.9	49.9	42.4
May.....	56.0	33.3	63.1	41.7	73.2	56.7	55.0	31.5	52.2	28.7	68.4	43.7	55.5	44.5
June.....	55.3	34.7	65.2	43.1	72.9	56.7	54.0	32.8	50.1	30.2	69.6	46.5	58.4	46.7
July.....	52.5	37.5	64.2	44.9	71.3	57.1	51.0	33.7	48.2	35.6	55.0	48.5	56.4	47.0
August.....	44.3	40.2	60.7	48.7	69.3	58.8	41.6	37.8	37.8	37.1	46.7	50.7	54.6	46.7
September.....	35.0	40.4	48.6	47.6	64.9	59.2	32.1	39.0	28.3	37.1	45.7	50.5	43.5	44.4
October.....	33.6	42.5	43.4	48.5	63.8	60.4	31.4	41.4	27.9	39.7	45.5	52.1	38.1	43.5
November.....	33.3	43.8	42.4	48.8	62.6	62.7	31.4	43.0	28.1	40.9	45.9	53.2	39.4	44.6
December.....	31.9	45.0	42.4	51.1	60.0	65.2	31.2	43.8	27.3	41.6	42.7	54.2	39.4	45.1

TABLE 38.—Condition of oat crop, United States, on first of months named, 1892-1912.

Year.	June.	July.	August.	When har-vested.	Year.	June.	July.	August.	When har-vested.	Year.	June.	July.	August.	When har-vested.
1892....	88.5	87.2	86.2	78.9	1899....	88.7	90.0	90.8	87.2	1906....	85.9	84.0	82.8	81.9
1893....	88.9	88.8	78.3	74.9	1900....	91.7	85.5	85.0	82.9	1907....	81.6	81.0	75.6	65.5
1894....	87.0	77.7	76.5	77.8	1901....	85.3	83.7	73.6	72.1	1908....	92.9	85.7	76.8	69.7
1895....	84.3	83.2	84.5	86.0	1902....	90.6	92.1	89.4	87.2	1909....	88.7	88.3	85.5	83.8
1896....	98.8	96.3	77.3	74.0	1903....	85.5	84.3	79.5	75.7	1910....	91.0	82.2	81.5	83.3
1897....	89.0	87.5	86.0	84.6	1904....	89.2	89.8	86.6	85.6	1911....	85.7	68.3	65.7	64.5
1898....	98.0	92.8	84.2	79.0	1905....	92.9	92.1	90.8	90.3	1912....	91.1	89.2	90.3	92.3

TABLE 39.—Wholesale price of oats per bushel, 1899-1912.

Date.	New York.		Baltimore.		Cincinnati.		Chicago.		Milwaukee.		Duluth.		Detroit.		San Francisco.	
	No. 2 mixed.		No. 2 mixed.		No. 2 mixed.		Contract. <sup>1</sup>		No. 3 white.		No. 3. <sup>2</sup>		No. 3 white. <sup>3</sup>		No. 1 white (per 100 lbs.).	
	Low.	High.	Low.	High.	Low.	High.	Low.	High.	Low.	High.	Low.	High.	Low.	High.	Low.	High.
1899....	25½	35½	24½	35	21½	31½	19½	28½	22½	31½	19½	30½	23½	33	1.22½	1.45
1900....	24½	29½	24	29½	21	28	21	26½	24	29	22½	28	24	29½	1.22½	1.40
1901....	28½	52	28	53	25	50½	23½	48½	25½	48½	25½	46½	28	60½	1.02½	1.55
1902....	32	65	29	60	27	57	25	56	30½	58	27½	47½	34½	61	1.15	1.50
1903....	38	44½	34½	44	31½	43½	31½	45	33½	41	31	40	35½	45	1.17½	1.37½
1904....	34½	55½	33	48	31	44½	28½	46	28½	45	27½	43	31½	48½	1.25	1.60
1905....	29	37½	27½	37	35	35½	25	34½	27½	35½	25½	32½	26½	37	1.37½	1.80
1906....	34	45	33½	45½	30	43	28½	42½	29	43	28½	41	32	43½	-----	-----
1907....	38½	63	39½	59½	37	55½	33½	56½	32½	56	33½	53	37	58	1.30	1.85
1908....	51	61½	50½	62	47	60	46	60½	45	62½	45½	57	47	64	1.40	1.75

<sup>1</sup> No. 2 grade, 1899-1906.

<sup>2</sup> No. 2 grade from 1899 to 1904 and 1906; "no grade" in 1905.

<sup>3</sup> No. 2 white, 1899-1906.



TABLE 39.—Wholesale price of oats per bushel, 1899-1912—Continued.

Date.	New York.		Baltimore.		Cincinnati.		Chicago.		Milwaukee.		Duluth.		Detroit.		San Francisco.		
	No. 2 mixed.		No. 2 mixed.		No. 2 mixed.		Contract.		No. 3 white.		No. 3.		No. 3 white.		No. 1 white (per 100 lbs.).		
	Low.	High.	Low.	High.	Low.	High.	Low.	High.	Low.	High.	Low.	High.	Low.	High.	Low.	High.	
1909.	Cts.	Cts.	Cts.	Cts.	Cts.	Cts.	Cts.	Cts.	Cts.	Cts.	Cts.	Cts.	Cts.	Cts.	Dolls.	Dolls.	
Jan....	53½	54	54	54½	51	53½	49½	50½	49	51½	48½	49½	52	53½	1.70	1.90	
Feb....	53½	57½	54	56	53	55	50	55½	55	55	48½	51	53	57	1.85	1.92½	
Mar....	56½	58	55½	58	53½	56½	52½	55	51½	55	50½	53	55	57	1.87½	2.02½	
Apr....	56½	58½	56	58	53	56½	53	56½	52½	56½	51½	53½	57½	57½	2.05	2.25	
May....	58½	62	58	62½	56	62	56½	62½	56	62½	53½	58½	57½	64½	2.15	2.25	
June....	59½	61½	58½	62½	55	60½	53½	59	49	59½	50	57	56½	62½	2.05	2.25	
July....	52½	59½	51	58½	45	55½	44	53½	46	55½	40	50	50	50	1.95	2.15	
Aug....	39½	52½	38½	52	35½	45	36½	43	35½	50	33	37	36½	51	.....	.....	
Sept....	39½	42	38½	42½	35½	42½	37½	43	37	41	34½	38½	39	41½	.....	.....	
Oct....	41	42½	42	43	40	43	38½	41	38½	42	35½	38½	41	43½	1.55	1.62½	
Nov....	42	43	42	43½	40½	42½	38½	39	38½	42	36½	39	41	41½	1.57	1.70	
Dec....	42½	47	43	49	41	47½	40	45	40	45½	39½	43½	42	46½	1.65	1.80	
Year.	39½	62	38½	62½	35½	62	36½	62½	35½	62½	33	58½	36½	64½	1.55	2.25	
1910.	Jan....	47	52	48½	53	47	52	44½	48½	45½	49½	43½	47½	47	51	1.60	1.75
Feb....	50	51	51	53	48	50	46½	49	46	49½	44½	46	44½	50	1.60	1.66½	
Mar....	48½	50	48	52	46	49½	43	47	41½	47	41	46	47	48½	1.60	1.67½	
Apr....	46	48½	46½	49	42½	47	41½	43	40	43	39½	41	44	46	1.50	1.60	
May....	42½	46½	44	47½	40	44½	36½	43	37	43	35½	41	41	45½	1.50	1.57½	
June....	41	45	43	44½	37	41	35	40½	35	40½	35	39	41	43	1.42½	1.55	
July....	45	48½	44	47	39	44½	38½	38	46	38½	43	40	43	40	1.42	1.65	
Aug....	35	47½	32½	47	32½	38½	32½	38½	33	42	33	38	34½	43	1.57	1.70	
Sept....	Nominal.	Nominal.	35½	37½	32	34½	31	31	32½	31	35	31	35	34	37	1.50	1.62½
Oct....	Nominal.	Nominal.	36	36	32	35	29½	32	30	35	29	32½	35	36	1.47	1.60	
Nov....	Nominal.	Nominal.	.....	.....	31½	34	30	31	31	33	31	32	34	35	1.47	1.50	
Dec....	Nominal.	Nominal.	.....	.....	32½	35	31	32	31	34	30	33	34	37	1.45	1.50	
Year.	47	52	35½	53	31½	52	29½	49	30½	49½	29	47½	34	51	1.42½	1.75	
1911.	No. 2 white.		No. 2 white.										Standard.				
Jan....	38	39½	37	38½	33½	35	30½	32½	31½	34	31	33	34	35	1.45	1.50	
Feb....	36	38	35½	37	31½	34½	30	31½	29½	32½	29	31½	32½	34	1.45	1.47½	
Mar....	35½	37	35½	37	31	33	28½	30	29	33	28	30	32	33	1.42	1.47	
Apr....	36½	40	35	38½	31	34	29	32	30	33	29	32	33	36	1.45	1.46	
May....	39½	43	38½	40½	32½	37	31	36	32	36	31	35	35	38	1.35	1.40	
June....	43	50	40	49	37	44	35	43	36	41	35	43	37	45	1.50	1.60	
July....	40½	53½	44	53	38	49	38	46	38	49	38	46	41	50	1.45	1.55	
Aug....	46	48	43	46	39	44	39	42	39	43	41	43	41	43	1.47	1.60	
Sept....	47	53	45	50	43	48	42	46	43	48	42	46	45	49	1.57	1.65	
Oct....	53	54	50½	51½	48	49	45	47	47	48	45	46	47	50	1.62	1.80	
Nov....	53	55	50½	54	47	51	44	47	46	49	44	46	49	51	1.72	1.85	
Dec....	53	55	52½	54	48	51	46	47	46	48	43	46	50	51	1.62	1.85	
Year.	35½	55	35½	54	31	51	28	47	29	49	28	46	32	51	1.35	1.85	
1912.	Jan....	53	58	52	57	50	53	46	51	52	44	48	50	53	1.70	1.75	
Feb....	58	61	57	59	54	56	51	52	51	52	49	50	53	54	1.75	1.78	
Mar....	60	61	58	60	54	57	51	54	52	55	50	52	55	58	1.75	1.87	
Apr....	61	64	60	65	57	61	54	58	52	59	52	56	53	63	1.85	2.10	
May....	61	63	59	65	54	59	50	58	52	58	48	55	56	63	2.02	2.12	
June....	60	63	58	61	52	56	50	53	50	56	49	53	55	58	1.85	2.00	
July....	52	62	53	66	46	55	42	57	44	57	44	50	52	61	1.65	1.95	
Aug....	39	62	39	66	32	41	31	35	32	54	31	51	33	61	1.60	1.65	
Sept....	38	40	40	41	33	35	31	34	32	34	30	31	35	38	1.55	1.65	
Oct....	.....	40	40	41	34	36	31	33	31	34	30	31	35	36	1.52	1.62	
Nov....	.....	37	37	40	32	35	30	31	30	32	30	33	36	47	1.52	1.62	
Dec....	.....	38	40	33	35	31	33	33	31	34	28	30	35	37	1.47	1.52	
Year.	38	64	37	66	32	61	30	58	30	59	28	56	33	63	1.47	2.12	

BARLEY.

TABLE 40.—Barley area of countries named, 1908–1912.

Country.	1908	1909	1910	1911	1912
<b>NORTH AMERICA.</b>					
United States.....	<i>Acres.</i> 6,646,000	<i>Acres.</i> 7,698,000	<i>Acres.</i> 7,743,000	<i>Acres.</i> 7,627,000	<i>Acres.</i> 7,530,000
Canada:					
New Brunswick.....	3,500	3,200	2,900	2,600	2,500
Quebec.....	109,600	108,400	104,000	106,000	91,300
Ontario.....	743,800	721,500	696,700	521,400	500,000
Manitoba.....	662,500	696,000	684,000	433,100	454,600
Saskatchewan.....	81,000	135,000	137,400	172,300	180,300
Alberta.....	129,800	186,000	194,500	156,400	174,900
Other.....	15,500	14,800	14,500	12,200	11,600
Total Canada.....	1,745,700	1,864,900	1,834,000	1,404,000	1,415,200
Mexico.....	( <sup>1</sup> )	( <sup>1</sup> )	( <sup>1</sup> )	( <sup>1</sup> )	( <sup>1</sup> )
<b>EUROPE.</b>					
Austria-Hungary:					
Austria.....	2,757,200	2,795,500	2,721,900	2,709,900	2,633,800
Hungary proper.....	2,647,500	2,857,800	2,715,700	2,737,100	2,602,600
Croatia-Slavonia.....	159,800	156,700	159,600	158,400	150,900
Bosnia-Herzegovina.....	262,200	204,400	202,600	179,900	( <sup>1</sup> )
Total Austria-Hungary.....	5,826,700	6,014,400	5,799,800	5,785,300	.....
Belgium.....	87,900	87,500	( <sup>1</sup> )	( <sup>1</sup> )	( <sup>1</sup> )
Bulgaria.....	621,100	596,000	643,300	620,700	( <sup>1</sup> )
Denmark.....	<sup>2</sup> 577,500	( <sup>1</sup> )	( <sup>1</sup> )	( <sup>1</sup> )	( <sup>1</sup> )
Finland.....	( <sup>1</sup> )	( <sup>1</sup> )	( <sup>1</sup> )	( <sup>1</sup> )	( <sup>1</sup> )
France.....	1,802,800	1,814,700	1,849,500	1,907,500	1,856,100
Germany.....	4,025,200	4,068,200	3,880,500	3,916,700	3,928,300
Italy.....	( <sup>1</sup> )	617,100	611,700	611,800	603,700
Netherlands.....	74,600	70,200	69,400	69,200	66,600
Norway.....	<sup>2</sup> 88,500	( <sup>1</sup> )	( <sup>1</sup> )	( <sup>1</sup> )	( <sup>1</sup> )
Roumania.....	1,532,500	1,357,100	1,357,500	1,253,300	1,235,200
Russia:					
Russia proper.....	21,913,700	21,816,000	22,930,900	23,012,500	.....
Poland.....	1,243,100	1,234,200	1,233,000	1,240,600	.....
Northern Caucasia.....	2,790,400	3,128,100	3,579,900	3,836,200	.....
Total Russia (European) <sup>3</sup> .....	25,947,200	26,178,300	27,743,800	28,089,200	<sup>4</sup> 28,873,300
Servia.....	254,800	281,500	265,700	254,700	( <sup>1</sup> )
Spain.....	3,466,700	3,480,000	3,333,200	3,567,400	3,298,300
Sweden.....	483,000	476,900	456,400	446,100	( <sup>1</sup> )
United Kingdom:					
England.....	1,383,300	1,379,100	1,449,500	1,337,400	1,365,000
Wales.....	86,700	85,300	87,600	86,800	91,500
Scotland.....	197,400	200,000	191,600	173,600	191,600
Ireland.....	154,600	163,100	168,000	158,200	165,400
Total United Kingdom.....	1,822,000	1,827,500	1,896,700	1,756,000	1,813,500
<b>ASIA.</b>					
Cyprus.....	( <sup>1</sup> )	( <sup>1</sup> )	( <sup>1</sup> )	( <sup>1</sup> )	( <sup>1</sup> )
Japanese Empire:					
Japan.....	3,266,300	3,136,200	3,176,500	3,173,400	3,132,400
Formosa.....	( <sup>1</sup> )	( <sup>1</sup> )	( <sup>1</sup> )	( <sup>1</sup> )	( <sup>1</sup> )
Russia:					
Central Asia.....	225,600	263,500	305,400	419,800	.....
Siberia.....	355,600	415,300	386,600	451,600	.....
Transcaucasia.....	1,100	1,100	1,700	1,900	.....
Total Russia (Asiatic) <sup>5</sup> .....	583,300	709,900	693,700	873,300	( <sup>6</sup> )

<sup>1</sup> No official statistics of area.  
<sup>2</sup> Area in 1907.  
<sup>3</sup> Exclusive of winter barley.

<sup>4</sup> Includes Asiatic Russia (10 Governments of).  
<sup>5</sup> Included in European Russia.

TABLE 40.—*Barley area of countries named, 1908-1912—Continued.*

Country.	1908	1909	1910	1911	1912
AFRICA.					
	<i>Acres.</i>	<i>Acres.</i>	<i>Acres.</i>	<i>Acres.</i>	<i>Acres.</i>
Algeria.....	3,168,500	3,442,500	3,418,500	3,320,500	3,430,500
Egypt.....	439,400	403,800	384,200	377,900	(1)
Tunis.....	1,088,800	1,109,500	1,186,100	1,193,200	1,119,400
Union of South Africa.....	(1)	(1)	(1)	(1)	(1)
AUSTRALASIA.					
Australia:					
Queensland.....	6,900	7,400	13,100	5,600	1,600
New South Wales.....	11,900	9,500	15,100	7,100	(1)
Victoria.....	63,100	65,200	58,600	52,700	(1)
South Australia.....	37,300	44,900	41,900	34,500	(1)
Western Australia.....	6,000	7,300	8,000	3,400	3,700
Tasmania.....	5,900	6,500	6,300	5,200	6,100
Total Australia.....	131,100	140,800	143,000	108,500	.....
New Zealand.....	36,200	48,900	41,500	33,500	31,600
Total Australasia.....	167,300	189,700	184,500	142,000	.....

<sup>1</sup> No official statistics of area.

TABLE 41.—*Barley crop of countries named, 1908-1912.*

Country.	1908	1909	1910	1911	1912
NORTH AMERICA.					
	<i>Bushels.</i>	<i>Bushels.</i>	<i>Bushels.</i>	<i>Bushels.</i>	<i>Bushels.</i>
United States.....	166,756,000	173,321,000	173,832,000	160,240,000	223,824,000
Canada:					
New Brunswick.....	79,000	94,000	73,000	74,000	69,000
Quebec.....	2,170,000	2,604,000	2,547,000	2,413,000	2,163,000
Ontario.....	21,124,000	20,952,000	20,727,000	13,760,000	14,745,000
Manitoba.....	17,093,000	20,866,000	13,326,000	14,447,000	14,965,000
Saskatchewan.....	1,952,000	4,493,000	3,598,000	5,445,000	5,926,000
Alberta.....	3,881,000	5,999,000	3,953,000	4,151,000	5,780,000
Other.....	463,000	390,000	424,000	341,000	366,000
Total Canada.....	46,762,000	55,398,000	45,148,000	40,631,000	44,014,000
Mexico.....	7,000,000	7,000,000	6,329,000	6,500,000	6,500,000
Total.....	220,518,000	235,719,000	225,309,000	207,371,000	274,338,000
EUROPE.					
Austria-Hungary:					
Austria.....	69,497,000	75,565,000	64,932,000	69,383,000	74,145,000
Hungary proper.....	56,324,000	71,868,000	53,630,000	73,595,000	70,140,000
Croatia-Slavonia.....	2,552,000	2,394,000	2,732,000	3,146,000	1,978,000
Bosnia-Herzegovina.....	2,389,000	3,755,000	3,787,000	2,970,000	2,857,000
Total Austria-Hungary.....	130,762,000	153,582,000	125,081,000	149,094,000	149,120,000
Belgium.....	4,409,000	4,574,000	3,748,000	4,595,000	4,000,000
Bulgaria.....	11,311,000	9,322,000	14,083,000	16,000,000	15,000,000
Denmark.....	20,166,000	21,599,000	21,793,000	21,016,000	22,900,000
Finland.....	5,131,000	4,887,000	5,000,000	6,631,000	6,754,000
France.....	40,673,000	46,144,000	43,477,000	47,631,000	50,646,000
Germany.....	140,538,000	160,551,000	133,330,000	145,132,000	159,924,000
Italy.....	9,000,000	10,951,000	9,483,000	10,882,000	8,403,000
Netherlands.....	3,953,000	3,332,000	3,104,000	3,416,000	4,000,000
Norway.....	3,028,000	2,596,000	2,900,000	2,550,000	3,086,000
Roumania.....	12,873,000	19,955,000	29,359,000	26,157,000	21,295,000
Russia:					
Russia proper.....	297,449,000	382,163,000	368,840,000	320,959,000	.....
Poland.....	23,790,000	26,671,000	21,959,000	27,938,000	.....
Northern Caucasia.....	46,219,000	55,906,000	62,709,000	55,296,000	.....
Total Russia (European) <sup>1</sup> .....	367,458,000	464,734,000	453,508,000	404,193,000	451,861,000

<sup>1</sup> Exclusive of winter barley.

TABLE 41.—*Barley crop of countries named, 1908–1912—Continued.*

Country.	1908	1909	1910	1911	1912
<b>EUROPE—continued.</b>					
	<i>Bushels.</i>	<i>Bushels.</i>	<i>Bushels.</i>	<i>Bushels.</i>	<i>Bushels.</i>
Servia.....	3,351,000	6,314,000	6,795,000	4,609,000	4,000,000
Spain.....	69,596,000	81,579,000	76,308,000	86,792,000	59,994,000
Sweden.....	15,520,000	13,900,000	14,763,000	13,725,000	13,660,000
<b>United Kingdom:</b>					
England.....	46,353,000	52,323,000	48,777,000	43,378,000	42,951,000
Wales.....	2,682,000	2,804,000	2,896,000	2,729,000	2,839,000
Scotland.....	7,410,000	7,731,000	6,578,000	6,488,000	7,115,000
Ireland.....	7,064,000	8,258,000	6,846,000	7,099,000	7,259,000
Total United Kingdom....	63,509,000	71,116,000	65,097,000	59,694,000	60,164,000
Total.....	901,278,000	1,075,136,000	1,007,829,000	1,002,117,000	1,034,807,000
<b>ASIA.</b>					
Cyprus.....	2,613,000	2,469,000	2,121,000	2,229,000	2,000,000
<b>Japanese Empire:</b>					
Japan.....	87,138,000	87,185,000	81,953,000	86,468,000	90,559,000
Formosa.....	34,000	34,000	44,000	50,000	50,000
Total Japanese Empire....	87,172,000	87,219,000	81,997,000	86,518,000	90,609,000
<b>Russia:</b>					
Central Asia.....	4,345,000	4,099,000	4,630,000	5,694,000	.....
Siberia.....	6,103,000	4,775,000	5,511,000	4,300,000	.....
Transcaucasia.....	13,000	10,000	29,000	27,000	.....
Total Russia (Asiatic) <sup>1</sup> ....	10,461,000	8,884,000	10,170,000	10,021,000	12,263,000
Total.....	100,246,000	98,572,000	94,288,000	98,768,000	104,872,000
<b>AFRICA.</b>					
Algeria.....	41,543,000	31,511,000	47,790,000	47,588,000	32,887,000
Tunis.....	5,057,000	9,186,000	6,660,000	13,319,000	4,823,000
Union of South Africa.....	3,000,000	3,000,000	3,000,000	3,000,000	3,000,000
Total.....	49,600,000	43,697,000	57,450,000	63,907,000	40,710,000
<b>AUSTRALASIA.</b>					
<b>Australia:</b>					
Queensland.....	67,000	142,000	200,000	86,000	16,000
New South Wales.....	77,000	172,000	281,000	85,000	135,000
Victoria.....	1,093,000	1,706,000	1,056,000	1,383,000	1,057,000
South Australia.....	585,000	852,000	713,000	562,000	725,000
Western Australia.....	79,000	77,000	105,000	35,000	38,000
Tasmania.....	154,000	190,000	158,000	147,000	153,000
Total Australia.....	2,055,000	3,139,000	2,513,000	2,298,000	2,124,000
New Zealand.....	1,200,000	2,000,000	1,345,000	950,000	956,000
Total Australasia.....	3,255,000	5,139,000	3,858,000	3,248,000	3,080,000
Grand total.....	1,274,897,000	1,458,263,000	1,388,734,000	1,375,411,000	1,457,807,000

<sup>1</sup> Exclusive of winter barley.

TABLE 42.—*Total production of barley in countries named in Table 41, 1895–1912.*

Year.	Production.	Year.	Production.	Year.	Production.	Year.	Production.
	<i>Bushels.</i>		<i>Bushels.</i>		<i>Bushels.</i>		<i>Bushels.</i>
1895.....	915,504,000	1900.....	959,622,000	1905.....	1,180,053,000	1910.....	1,388,734,000
1896.....	932,100,000	1901.....	1,072,195,000	1906.....	1,296,579,000	1911.....	1,375,411,000
1897.....	864,605,000	1902.....	1,229,132,000	1907.....	1,271,237,000	1912.....	1,457,807,000
1898.....	1,030,581,000	1903.....	1,235,786,000	1908.....	1,274,897,000		
1899.....	965,720,000	1904.....	1,175,784,000	1909.....	1,458,263,000		

TABLE 43.—Average yield of barley in countries named, bushels per acre, 1890-1912.

Year.	United States.	Russia, European. <sup>1</sup>	Germany. <sup>1</sup>	Austria. <sup>1</sup>	Hungary proper. <sup>1</sup>	France. <sup>2</sup>	United Kingdom. <sup>2</sup>
Average:							
1890-1899 .....	23.4	13.3	29.4	21.1	.....	22.6	39.8
1900-1909 .....	25.5	14.3	35.3	26.3	23.4	23.6	35.0
1903 .....	26.4	15.5	36.3	24.8	25.1	25.2	33.4
1904 .....	27.2	14.4	33.7	22.8	19.7	22.0	32.3
1905 .....	26.8	14.3	33.3	24.0	24.5	23.4	35.9
1906 .....	28.3	13.0	35.2	26.1	26.8	20.8	36.1
1907 .....	23.8	14.2	38.2	27.3	23.1	24.4	36.8
1908 .....	25.1	14.2	34.9	25.2	21.3	22.6	34.9
1909 .....	22.5	17.9	39.5	28.2	25.1	26.2	38.9
1910 .....	22.5	16.2	34.4	24.8	19.7	23.5	31.5
1911 .....	21.0	14.2	37.1	27.5	26.3	25.5	34.0
1912 .....	29.7	16.1	40.7	29.8	26.7	27.3	33.0
Average (1903-1912).....	25.3	15.0	36.3	26.0	23.8	24.1	34.7

<sup>1</sup> Bushels of 48 pounds.<sup>2</sup> Winchester bushels.<sup>3</sup> Includes Asiatic Russia.

TABLE 44.—Acreage, production, value, exports, etc., of barley, United States, 1849-1912.

Year.	Acreage sown and harvested.	Average yield per acre.	Production.	Average farm price per bushel Dec. 1.	Farm value Dec. 1.	Chicago cash price per bushel, No. 2. <sup>1</sup>				Domestic exports, fiscal year beginning July 1.	Imports, fiscal year beginning July 1.
						December. <sup>2</sup>		May of following year. <sup>2</sup>			
						Low.	High.	Low.	High.		
1849 <sup>3</sup> .....			5,167,000								
1850 <sup>3</sup> .....			15,826,000								
1856 .....	493,000	22.9	11,284,000	70.2	7,916,000	59	70	85	100		3,247,250
1867 .....	1,131,000	22.7	25,727,000	70.1	18,028,000	150	180	227	250	9,810	3,783,966
1868 .....	937,000	24.4	22,896,000	109.0	24,948,000	140	170	149	175	59,077	5,069,880
1869 .....	1,026,000	27.9	28,652,000	70.8	20,298,000	74	85	50	62	255,490	6,727,597
1869 <sup>3</sup> .....			29,761,000								
1870 .....	1,109,000	23.7	26,295,000	79.1	20,792,000	68	80	72	95	340,093	4,866,700
1871 .....	1,114,000	24.0	26,718,000	75.8	20,264,000	55 <sup>1</sup>	64	55	71	86,891	5,565,501
1872 .....	1,397,000	19.2	26,846,000	68.6	18,416,000	60	70	71	85	482,410	4,244,751
1873 .....	1,387,000	23.1	32,044,000	86.7	27,794,000	132	158	130	155	320,399	4,891,189
1874 .....	1,581,000	20.6	32,552,000	86.0	27,998,000	120	129 <sup>1</sup>	115	137	91,118	6,255,063
1875 .....	1,790,000	20.6	36,909,000	74.1	27,368,000	81	88	62 <sup>1</sup>	72 <sup>1</sup>	317,781	10,285,957
1876 .....	1,767,000	21.9	38,710,000	63.0	24,403,000	63 <sup>1</sup>	68 <sup>1</sup>	80	85	1,156,129	6,702,965
1877 .....	1,669,000	21.4	35,638,000	62.5	22,287,000	56 <sup>1</sup>	64	46 <sup>1</sup>	52 <sup>1</sup>	3,921,501	6,764,228
1878 .....	1,790,000	23.6	42,246,000	57.9	24,454,000	91	100	64	73	715,536	5,720,979
1879 .....	1,681,000	24.0	40,283,000	58.9	23,714,000	86	92	75	80	1,128,923	7,135,258
1879 <sup>3</sup> .....	1,998,000	22.0	43,997,000								
1880 .....	1,843,000	24.5	45,165,000	66.6	30,091,000	100	120	95	105	885,246	9,528,616
1881 .....	1,968,000	20.9	41,161,000	82.3	33,863,000	101	107	100	100	205,930	12,182,722
1882 .....	2,272,000	21.5	48,954,000	62.9	30,768,000	79	82	80	80	453,005	10,050,687
1883 .....	2,379,000	21.1	50,136,000	58.7	29,420,000	62	67	65	74	724,955	8,596,122
1884 .....	2,609,000	23.5	61,203,000	48.7	29,779,000	53	58	65	65	629,130	9,986,507
1885 .....	2,729,000	21.4	58,360,000	56.3	32,868,000	62	65	58	60	252,183	10,197,115
1886 .....	2,653,000	22.4	59,428,000	53.6	31,841,000	51	54	57	57	1,305,300	10,355,594
1887 .....	2,902,000	19.6	56,812,000	51.9	29,464,000	80	80	69	77	550,884	10,831,461
1888 .....	2,996,000	21.3	63,884,000	59.0	37,672,000	.....	.....	.....	.....	1,440,321	11,368,414
1889 .....	3,221,000	21.7	78,333,000	41.6	32,614,000	58	58	.....	.....	1,408,311	11,332,545
1889 <sup>3</sup> .....	3,221,000	24.3	78,533,000								
1890 .....	3,135,000	21.4	67,168,000	62.7	42,141,000	.....	.....	.....	.....	973,062	5,078,733
1891 .....	3,353,000	25.9	86,839,000	52.4	45,470,000	.....	.....	.....	.....	2,800,075	3,146,328
1892 .....	3,400,000	23.6	80,097,000	47.5	38,026,000	65	67	65	65	3,035,267	1,970,129
1893 .....	3,220,000	21.7	69,869,000	41.1	28,729,000	52	54	55	60	5,219,405	791,061
1894 .....	3,171,000	19.4	61,400,000	44.2	27,134,000	53 <sup>1</sup>	55 <sup>1</sup>	51	52	1,563,754	2,116,816

<sup>1</sup> Prices 1895 and subsequent years are for No. 3 grade.<sup>2</sup> Low malting to fancy since 1908.<sup>3</sup> Census figures.

TABLE 44.—Acreage, production, value, exports, etc., of barley, United States, 1849-1912—Continued.

Year.	Acreage sown and harvested.	Average yield per acre.	Production.	Average farm price per bushel Dec. 1.	Farm value Dec. 1.	Chicago cash price per bushel, No. 2.				Domestic exports, fiscal year beginning July 1.	Imports, fiscal year beginning July 1.
						December.		May of following year.			
						Low.	High.	Low.	High.		
	<i>Acres.</i>	<i>Bush.</i>	<i>Bushels.</i>	<i>Cents.</i>	<i>Dollars.</i>	<i>Cents.</i>	<i>Cents.</i>	<i>Cents.</i>	<i>Cents.</i>	<i>Bushels.</i>	<i>Bushels.</i>
1895...	3,300,000	26.4	87,073,000	33.7	29,312,000	33	40	25	36	7,680,331	837,384
1896...	2,951,000	23.6	69,695,000	32.3	22,491,000	22	37	24½	35	20,030,301	1,271,787
1897...	2,719,000	24.5	66,685,000	37.7	25,142,000	25½	42	36	53	11,237,077	124,804
1898...	2,583,000	21.6	55,792,000	41.3	23,064,000	40	50½	36	42	2,267,403	110,475
1899...	2,878,000	25.5	73,382,000	40.3	29,594,000	35	45	36	44	23,661,662	189,757
1899 <sup>1</sup>	4,470,000	26.8	119,635,000	.....	.....	.....	.....	.....	.....	.....	.....
1900...	2,894,000	20.4	58,926,000	40.9	24,075,000	37	61	37	57	6,293,207	171,004
1901...	4,296,000	25.6	109,933,000	45.2	49,705,000	56	63	64	72	8,714,268	57,406
1902...	4,661,000	29.0	134,954,000	45.9	61,899,000	36	70	48	56	8,429,141	56,462
1903...	4,993,000	26.4	131,861,000	45.6	60,166,000	42	61½	38	59	10,881,627	90,708
1904...	5,146,000	27.2	139,749,000	42.0	58,652,000	38	52	40	50	10,661,655	81,020
1905...	5,096,000	26.8	136,551,000	40.5	54,993,000	37	53	42	55½	17,729,360	18,049
1906...	6,324,000	28.3	178,916,000	41.5	74,236,000	44	56	66	85	8,238,842	38,319
1907...	6,448,000	23.8	153,597,000	66.6	102,290,000	78	102	60	75	4,349,078	199,741
1908...	6,646,000	25.1	166,756,000	55.4	92,442,000	57	64½	66	75	6,580,393	2,644
1909...	7,011,000	24.3	170,284,000	55.2	93,971,000	55	72	50	68	4,311,566	.....
1909 <sup>1</sup>	7,698,000	22.5	173,321,000	.....	.....	.....	.....	.....	.....	.....	.....
1910 <sup>1</sup>	7,743,000	22.5	173,832,000	57.8	100,426,000	72	90	75	115	9,399,346	.....
1911 <sup>1</sup>	7,627,000	21.0	160,240,000	86.9	139,182,000	102	130	68	132	1,585,242	.....
1912...	7,530,000	29.7	223,824,000	50.4	112,957,000	43	.....	.....	.....	.....	.....

<sup>1</sup> Census figures.

<sup>2</sup> Figures adjusted to census basis.

TABLE 45.—Acreage, production, and farm value of barley, by States, 1912

State and division.	Acreage.	Production.	Farm value Dec. 1.	State and division.	Acreage.	Production.	Farm value Dec. 1.
	<i>Acres.</i>	<i>Bushels.</i>	<i>Dollars.</i>		<i>Acres.</i>	<i>Bushels.</i>	<i>Dollars.</i>
Maine.....	4,000	105,000	81,000	Nebraska.....	113,000	2,486,000	1,044,000
N. Hampshire.....	1,000	28,000	24,000	Kansas.....	176,000	4,136,000	1,654,000
Vermont.....	13,000	455,000	364,000	N. C. W. of Miss. River.	4,318,000	121,583,000	49,592,000
New York.....	82,000	2,132,000	1,450,000	Kentucky.....	3,000	78,000	58,000
Pennsylvania.....	7,000	192,000	131,000	Tennessee.....	2,000	52,000	42,000
N. Atlantic...	107,000	2,912,000	2,050,000	Texas.....	6,000	176,000	137,000
Maryland.....	4,000	108,000	73,000	Oklahoma.....	8,000	160,000	80,000
Virginia.....	10,000	250,000	188,000	S. Central...	19,000	466,000	317,000
S. Atlantic...	14,000	358,000	261,000	Montana.....	39,000	1,424,000	755,000
Ohio.....	20,000	620,000	341,000	Wyoming.....	11,000	374,000	232,000
Indiana.....	9,000	266,000	160,000	Colorado.....	76,000	2,964,000	1,482,000
Illinois.....	57,000	1,796,000	952,000	New Mexico.....	2,000	70,000	50,000
Michigan.....	87,000	2,262,000	1,470,000	Arizona.....	36,000	1,440,000	1,253,000
Wisconsin.....	845,000	24,843,000	13,664,000	Utah.....	25,000	1,125,000	664,000
N. C. E. of Miss. River.	1,018,000	29,787,000	16,587,000	Nevada.....	12,000	492,000	428,000
Minnesota.....	1,490,000	42,018,000	17,227,000	Idaho.....	159,000	6,916,000	3,527,000
Iowa.....	470,000	14,570,000	7,576,000	Washington.....	183,000	7,869,000	4,171,000
Missouri.....	6,000	149,000	98,000	Oregon.....	119,000	4,284,000	2,356,000
North Dakota.....	1,176,000	35,162,000	12,307,000	California.....	1,392,000	41,760,000	29,232,000
South Dakota.....	887,000	23,062,000	9,686,000	Far Western.	2,054,000	68,718,000	44,150,000
				United States	7,530,000	223,824,000	112,957,000

TABLE 46.—Yield per acre, price per bushel, and value per acre of barley, by States.

State and division.	Yield per acre.							Farm price per bushel.											Value per acre, 1912. <sup>1</sup>						
	10-year averages.							10-year averages for Dec. 1.						Quarterly, 1912.											
	1870-1879				1880-1889			1890-1899		1900-1909		Dec. 1, 1910.		Dec. 1, 1911.		Mar. 1.				June 1.		Sept. 1.		Dec. 1.	
	Bu.	Bu.	Bu.	Bu.	Bu.	Bu.	Bu.	Bu.	Bu.	Cts.	Cts.	Cts.	Cts.	Cts.	Cts.	Cts.	Cts.	Cts.		Cts.	Cts.	Cts.	Cts.	Cts.	Dols.
Maine.....	20.2	21.8	26.5	29.2	31.0	28.0	26.2	84	74	61	71	76	90	88	100	85	77	20.17							
New Hampshire.....	23.8	21.9	24.5	22.1	26.0	24.0	28.0	84	74	65	76	77	86	85	90	95	84	23.52							
Vermont.....	25.1	24.8	28.7	30.6	31.0	30.5	35.0	89	72	56	64	68	82	97	115	100	80	28.00							
New York.....	22.0	22.7	22.0	24.6	28.3	25.0	26.0	79	72	59	60	70	97	102	105	79	68	17.68							
Pennsylvania.....	22.2	20.5	20.0	24.2	26.5	25.0	27.5	84	72	50	58	63	65	75	81	72	68	18.70							
N. Atlantic.....	21.9	22.6	22.6	25.3	28.5	25.7	27.2	79.5	72.4	59.1	61.6	69.6	92.6	98.7	104.5	81.8	70.4	19.16							
Maryland.....	18.2	25.3	22.4	27.7	31.0	23.0	27.0	79	74	55	55	61	60	.....	.....	60	68	18.36							
Virginia.....	17.1	16.5	19.5	26.0	29.3	23.0	25.0	72	72	58	59	67	70	.....	82	81	75	18.75							
S. Atlantic.....	15.0	15.8	21.2	26.6	29.8	23.0	25.6	80.4	78.4	56.2	57.7	65.2	67.1	.....	82.0	74.0	72.9	18.64							
Ohio.....	24.0	22.1	25.4	27.3	28.5	27.2	31.0	75	70	49	53	60	84	85	94	59	55	17.05							
Indiana.....	22.5	22.3	21.1	25.4	27.0	26.5	29.5	79	66	47	53	56	75	70	82	54	60	17.70							
Illinois.....	22.4	21.7	23.6	27.8	30.2	28.0	31.5	62	60	45	50	56	92	93	91	55	53	16.70							
Michigan.....	22.5	23.3	21.8	25.0	26.0	24.0	26.0	76	66	50	55	58	86	89	89	68	65	16.90							
Wisconsin.....	26.3	23.9	27.1	28.6	25.9	25.5	29.4	66	55	42	51	64	99	104	104	61	55	16.17							
N. C. E. Miss. R....	23.8	23.2	26.1	28.2	26.2	25.5	29.3	68.0	58.6	43.7	51.0	62.7	96.9	101.4	101.6	61.2	55.7	16.29							
Minnesota.....	26.1	24.2	26.2	25.7	21.0	19.0	28.2	52	48	35	42	60	96	98	96	42	41	11.56							
Iowa.....	23.8	22.2	23.9	25.6	29.5	21.9	31.0	48	47	34	41	56	93	100	102	54	52	16.12							
Missouri.....	21.7	20.4	19.9	21.9	27.0	20.0	24.8	73	59	44	55	60	75	.....	100	70	66	16.37							
North Dakota.....	20.9	22.8	23.0	5.5	19.5	29.9	.....	42	32	38	55	85	86	86	40	35	10.46								
South Dakota.....	20.2	20.5	25.3	18.2	5.4	26.0	.....	42	31	39	57	88	94	99	44	42	10.92								
Nebraska.....	25.2	19.4	20.8	24.0	18.5	11.0	22.0	45	39	32	37	45	60	78	89	49	42	9.24							
Kansas.....	22.4	18.9	16.8	19.8	18.0	6.5	23.5	52	45	35	41	45	60	100	94	43	40	9.40							
N. C. W. Miss. R....	23.9	21.8	23.8	24.6	17.4	15.4	28.2	48.8	45.7	33.8	40.5	56.7	90.0	94.0	94.0	43.7	40.8	11.48							
Kentucky.....	23.1	21.8	21.7	24.0	24.0	28.7	26.0	82	66	46	63	65	79	.....	88	.....	75	19.50							
Tennessee.....	19.4	13.9	16.6	20.4	23.0	28.0	26.0	76	68	57	66	80	90	93	99	100	80	20.80							
Texas.....	27.8	16.9	17.3	22.4	30.0	28.0	29.3	94	69	59	75	90	93	.....	111	77	78	22.85							
Oklahoma.....	.....	.....	26.2	30.0	10.0	20.0	.....	.....	.....	47	54	61	.....	.....	68	55	50	10.00							
S. Central.....	23.1	19.0	19.0	24.6	28.2	17.1	24.5	81.8	66.2	52.5	53.9	66.8	80.3	93.0	91.5	77.3	68.0	16.68							
Montana.....	.....	28.6	29.8	36.2	28.0	34.5	36.5	.....	67	57	57	62	68	75	82	66	53	19.34							
Wyoming.....	.....	24.3	29.9	30.0	34.0	34.0	.....	.....	65	67	67	75	81	92	.....	62	21.08								
Colorado.....	29.4	24.2	26.9	33.8	32.0	29.0	39.0	194	75	55	59	60	69	71	81	40	50	19.50							
New Mexico.....	.....	20.1	25.5	28.0	25.0	33.0	35.0	.....	73	63	73	80	70	75	55	50	71	24.85							
Arizona.....	.....	19.8	23.6	35.6	36.0	36.5	40.0	.....	70	66	81	90	87	73	76	70	87	34.80							
Utah.....	.....	22.9	29.9	34.6	43.0	45.0	.....	.....	58	50	57	60	66	79	74	56	59	26.55							
Nevada.....	27.2	22.9	28.6	35.2	40.0	40.0	41.0	124	81	62	76	70	81	75	96	102	87	35.67							
Idaho.....	.....	26.8	28.3	39.8	33.0	42.0	43.5	.....	64	48	54	50	70	67	83	47	51	22.18							
Washington.....	.....	29.0	33.9	38.0	29.0	37.0	43.0	.....	56	45	50	57	68	76	73	53	53	22.79							
Oregon.....	27.9	25.7	27.0	32.2	31.5	34.0	36.0	65	54	47	55	62	65	74	76	56	55	19.80							
California.....	20.8	20.6	20.9	24.5	31.0	28.0	30.0	82	62	53	61	55	85	89	86	63	70	21.00							
Far Western.....	21.2	21.2	22.0	27.0	31.2	28.0	33.5	83.2	62.6	51.9	58.7	56.4	79.4	83.2	83.2	59.6	64.2	21.49							
United States.....	22.2	22.0	23.4	25.7	22.5	21.0	29.7	71.3	58.2	43.3	47.9	57.8	86.9	91.0	91.4	53.5	50.5	15.00							

<sup>1</sup> Basis, Dec. 1 price.

TABLE 47.—Condition of barley crop, United States, on first of months named, 1891–1912.

Year.	June.	July.	Aug- gust.	When har- vested.	Year.	June.	July.	Aug- gust.	When har- vested.
	<i>P. ct.</i>	<i>P. ct.</i>	<i>P. ct.</i>	<i>P. ct.</i>		<i>P. ct.</i>	<i>P. ct.</i>	<i>P. ct.</i>	<i>P. ct.</i>
1891.....	90.3	90.9	93.8	94.3	1902.....	93.6	93.7	90.2	89.7
1892.....	92.1	92.0	91.1	87.4	1903.....	91.5	86.8	83.4	82.1
1893.....	88.3	88.8	84.6	83.8	1904.....	90.5	88.5	88.1	87.4
1894.....	82.2	76.8	69.8	71.5	1905.....	93.7	91.5	89.5	87.8
1895.....	90.3	91.9	87.2	87.6	1906.....	93.5	92.5	90.3	89.4
1896.....	98.0	88.1	82.9	83.1	1907.....	84.9	84.4	84.5	78.5
1897.....	87.4	88.5	87.5	86.4	1908.....	89.7	86.2	83.1	81.2
1898.....	78.8	85.7	79.3	79.2	1909.....	90.6	90.2	85.4	80.5
1899.....	91.4	92.0	93.6	86.7	1910.....	89.6	73.7	70.0	69.8
1900.....	86.2	76.3	71.6	70.7	1911.....	90.2	72.1	66.2	65.5
1901.....	91.0	91.3	86.9	83.8	1912.....	91.1	88.3	89.1	88.9

TABLE 48.—Farm price of barley per bushel on first of each month, 1911–12.

Month.	United States.		North Atlantic States.		South Atlantic States.		N. Cen. States East of Miss R.		N. Cen. States West of Miss R.		South Central States.		Far West- ern States.	
	1912	1911	1912	1911	1912	1911	1912	1911	1912	1911	1912	1911	1912	1911
	<i>Cts.</i>	<i>Cts.</i>	<i>Cts.</i>	<i>Cts.</i>	<i>Cts.</i>	<i>Cts.</i>	<i>Cts.</i>	<i>Cts.</i>	<i>Cts.</i>	<i>Cts.</i>	<i>Cts.</i>	<i>Cts.</i>	<i>Cts.</i>	<i>Cts.</i>
January.....	86.4	59.8	94.0	70.2	63.3	65.0	99.6	70.0	88.0	62.4	69.0	50.0	79.1	51.2
February.....	91.2	64.1	94.9	73.8	70.0	65.0	105.8	76.1	93.7	68.8	89.0	48.0	82.6	52.4
March.....	91.0	63.0	98.7	72.2	.....	59.0	101.4	77.4	94.0	66.1	93.0	57.0	83.2	52.2
April.....	92.3	69.1	96.0	75.0	68.3	56.0	104.6	85.0	95.8	75.2	74.0	57.0	83.8	54.0
May.....	96.2	74.0	97.9	75.5	77.3	64.0	106.9	86.7	99.9	79.5	110.0	58.3	88.0	61.5
June.....	91.1	73.8	104.5	77.9	82.0	70.0	101.6	82.2	94.0	73.6	91.5	68.0	83.2	70.1
July.....	81.9	70.1	103.1	74.4	78.0	62.0	95.9	81.6	80.4	72.8	75.0	47.0	77.0	61.4
August.....	66.8	69.3	92.4	80.5	77.3	67.0	83.3	78.8	56.9	71.8	71.7	55.7	69.5	61.5
September.....	53.5	77.0	81.8	82.8	74.0	70.0	61.2	87.5	43.7	80.6	77.3	77.5	59.6	67.4
October.....	54.8	81.7	75.7	87.5	70.7	65.0	57.6	96.4	43.8	85.4	71.0	74.2	64.5	70.1
November.....	53.8	84.9	74.9	91.9	69.7	65.0	56.0	99.1	43.7	89.4	72.8	65.8	62.7	72.8
December.....	50.4	86.9	70.4	92.5	72.9	67.1	55.7	96.9	40.8	90.0	68.0	80.3	64.2	79.4

TABLE 49.—Wholesale price of barley per bushel, 1899–1912.

Date.	Cincinnati.		Chicago.		Milwaukee.		San Francisco.	
	Extra No. 3 spring.		Low malting to fancy. <sup>1</sup>		Extra No. 3.		No. 1 feed <sup>2</sup> (per 100 lbs.).	
	Low.	High.	Low.	High.	Low.	High.	Low.	High.
1899.....	<i>Cents.</i>	<i>Cents.</i>	<i>Cents.</i>	<i>Cents.</i>	<i>Cents.</i>	<i>Cents.</i>	<i>Dolls.</i>	<i>Dolls.</i>
1900.....	44	56	34	54	.....	.....	0.85	1.47½
1901.....	44½	66	34	62	.....	.....	.67½	.75
1902.....	58	70	36	65	.....	.....	.73½	.85
1903.....	55	74	35	73	.....	.....	.80	1.32½
1904.....	55	71	42	63	48	63	.90	1.22½
1905.....	55	69	35	61	41	61	1.95.	1.15
1906.....	52	58	36½	55	41	54	1.02½	1.35
1907.....	52	62	38	58	43½	56	.....	.....
1908.....	54	113	45	110	49	111	1.12½	1.72½
	67	115	49	106	50	105	1.22½	1.57½

<sup>1</sup> No. 3, 1899–1908.

<sup>2</sup> No. 1 brewing 1899–1904, and 1907.



TABLE 49.—Wholesale price of barley per bushel, 1899—1912—Continued.

Date.	Cincinnati.		Chicago.		Milwaukee.		San Francisco.	
	Extra No. 3 spring.		Low malting to fancy.		Extra No. 3.		No. 1 feed (per 100 lbs.).	
	Low.	High.	Low.	High.	Low.	High.	Low.	High.
1909.								
January.....	Cents. 67	Cents. 70	Cents. 59	Cents. 66	Cents. 62	Cents. 66	Dolls. 1.36½	Dolls. 1.43½
February.....	70	71	60½	66½	62	66½	1.37½	1.42½
March.....	71	72	63	68	63	67½	1.40	1.50
April.....	71	72	62	68	63½	68	1.47½	1.65
May.....	73	74	66	75	60	77	1.55	1.70
June.....	74	84	70	82½	65	82½	1.40	1.60
July.....	75	76	62	78	64½	72	1.42½	1.48½
August.....			50	70	54	68	1.35	1.45
September.....	64	68	50	66	59	68	1.35	1.40
October.....	64	67	50	66	55	67	1.35	1.45
November.....	66	68	53	67½	60	67	1.43½	1.47½
December.....	70	76	55	72	64	70	1.45	1.52½
Year.....	64	84	50	82½	54	82½	1.35	1.70
1910.								
January.....	76	80	63	74	68 <sup>(1)</sup>	73	1.32½	1.50
February.....	73	80	64	73	67	72	1.35	1.40
March.....	69	78	56	73	67	72	1.35	1.45
April.....	67	74	50	70	59	70½	1.10	1.35
May.....	67	72	50	68	60	67	1.06½	1.15
June.....	70	72	52	69	60	66½	1.00	1.10
July.....	70	80	50	77	62	75	1.00	1.10
August.....	75	80	54	75	62	75	.95	1.08½
September.....	72	81	60	75	67	74	.97½	1.06½
October.....	74	82	63	77	68½	76	.95	1.02½
November.....	80	86	66	83½	71	82	.95	1.03½
December.....	72	86	72	90	74½	90	1.02½	1.11½
Year.....	67	86	50	90	59	90	.95	1.50
1911.								
January.....	90 <sup>(2)</sup>	106	78	100	86	100	1.10	1.15
February.....	88	100	75	98	82	96	1.11½	1.16½
March.....	90	115	79	114	88	115	1.11½	1.42½
April.....	96	115	90	117	100	116	1.40	1.50
May.....	94	114	75	115	80	113	1.37½	1.50
June.....	90	108	70	117	80	116	1.23½	1.40
July.....			80	117	94	114	1.26½	1.35
August.....			80	124	93	122	1.32½	1.60
September.....	95	123	90	125	108	124	1.55	1.67½
October.....	110	123	98	126	113	125	1.67½	1.90
November.....	110	125	100	139	118	130	1.82½	1.98½
December.....	110	125	102	130	120	127	1.75	1.85
Year.....	88	125	70	139	80	130	1.10	1.98½
1912.								
January.....	110	132	98	137	126 <sup>(3)</sup>	134	1.87½	1.95
February.....	110	132	70	132	124	132	1.85	1.92½
March.....	110	132	70	138	125	137	1.80	1.87½
April.....	110	132	80	140	134	138	1.87½	1.95
May.....			68	132	120	136	1.78½	1.92½
June.....			60	122	95	123	1.52½	1.71½
July.....			45	110	82	110	1.25	1.47½
August.....	67	75	40	82	64	81	1.15	1.45
September.....	67	78	40	76	64	75	1.40	1.50
October.....	65	78	47	76	68	75	1.40	1.52½
November.....	65	78	44	77	65	75	1.42½	1.52
December.....	55	78	43	77	64	73	1.35	1.47½
Year.....	55	132	40	140	64	138	1.15	1.95

<sup>1</sup> Medium No. 3 from May to December, inclusive.

<sup>2</sup> No. 3 spring.

<sup>3</sup> Medium.

## RYE.

TABLE 50.—*Rye area of countries named, 1908-1912.*

Country.	1908	1909	1910	1911	1912
<b>NORTH AMERICA.</b>					
United States.....	<i>Acres.</i> 1,948,000	<i>Acres.</i> 2,196,000	<i>Acres.</i> 2,185,000	<i>Acres.</i> 2,127,000	<i>Acres.</i> 2,117,000
Canada:					
Quebec.....	20,200	19,000	17,700	20,400	19,200
Ontario.....	63,400	57,300	52,500	98,900	95,000
Manitoba.....	6,300	4,700	3,800	9,400	.....
Saskatchewan.....	3,000	2,700	3,400	2,200	.....
Alberta.....	6,500	6,800	6,200	20,700	21,000
Other.....	900	800	500	1,700	900
Total Canada.....	100,300	91,300	84,100	153,300	136,100
Mexico.....	( <sup>1</sup> )	( <sup>1</sup> )	( <sup>1</sup> )	( <sup>1</sup> )	( <sup>1</sup> )
<b>EUROPE.</b>					
Austria-Hungary:					
Austria.....	5,139,100	5,134,700	5,092,700	4,994,700	5,021,400
Hungary proper.....	2,575,000	2,485,700	2,634,500	2,690,800	2,794,800
Croatia-Slavonia.....	175,100	172,100	221,400	175,700	164,700
Bosnia-Herzegovina.....	31,100	28,200	30,900	30,300	( <sup>1</sup> )
Total Austria-Hungary.....	7,920,300	7,820,700	7,979,500	7,891,500	.....
Belgium.....	637,900	636,400	( <sup>1</sup> )	( <sup>1</sup> )	( <sup>1</sup> )
Bulgaria.....	429,300	498,000	561,300	545,400	( <sup>1</sup> )
Denmark.....	<sup>2</sup> 682,000	( <sup>1</sup> )	( <sup>1</sup> )	( <sup>1</sup> )	( <sup>1</sup> )
Finland.....	( <sup>1</sup> )	( <sup>1</sup> )	( <sup>1</sup> )	( <sup>1</sup> )	( <sup>1</sup> )
France.....	3,074,700	3,031,900	2,994,200	2,902,000	2,994,500
Germany.....	15,122,400	15,149,000	15,287,500	15,161,100	15,488,800
Italy.....	( <sup>1</sup> )	300,700	300,800	302,200	304,800
Netherlands.....	548,800	553,400	548,600	556,900	558,400
Norway.....	<sup>2</sup> 37,100	( <sup>1</sup> )	( <sup>1</sup> )	( <sup>1</sup> )	( <sup>1</sup> )
Roumania.....	363,400	337,500	429,600	325,700	265,000
Russia:					
Russia proper.....	63,009,500	63,800,500	62,966,900	65,058,400	.....
Poland.....	5,130,100	5,204,400	5,253,100	5,257,900	.....
Northern Caucasia.....	553,300	585,500	593,900	520,400	.....
Total Russia (European).....	68,692,900	69,590,400	68,813,900	70,836,700	<sup>3</sup> 72,932,900
Servia.....	117,800	122,900	124,600	123,300	( <sup>1</sup> )
Spain.....	2,246,800	2,058,000	2,029,700	1,987,400	1,944,400
Sweden.....	999,500	998,300	997,500	988,700	( <sup>1</sup> )
United Kingdom.....	60,800	63,000	56,900	55,400	62,000
<b>ASIA.</b>					
Russia:					
Central Asia.....	140,100	189,500	215,100	240,900	.....
Siberia.....	2,265,400	2,201,600	2,021,700	2,112,300	.....
Transcaucasia.....	1,100	1,600	1,600	1,100	.....
Total Russia (Asiatic).....	2,406,600	2,392,700	2,238,400	2,354,800	( <sup>4</sup> )
<b>AUSTRALASIA.</b>					
Australia:					
Queensland.....	100	100	200	100	( <sup>1</sup> )
New South Wales.....	5,300	4,700	5,400	4,200	( <sup>1</sup> )
Victoria.....	1,400	2,000	2,400	( <sup>1</sup> ) 2,400	( <sup>1</sup> )
South Australia.....	.....	.....	1,500	1,000	( <sup>1</sup> )
Western Australia.....	600	600	1,100	800	( <sup>1</sup> )
Tasmania.....	700	700	1,100	1,300	( <sup>1</sup> )
New Zealand.....	3,000	3,500	( <sup>1</sup> )	4,400	( <sup>1</sup> )
Total Australasia.....	11,100	11,600	11,700	11,800	.....

<sup>1</sup> No official statistics of area.<sup>2</sup> Area in 1907.<sup>3</sup> Includes Asiatic Russia, 10 governments of.<sup>4</sup> Included under European Russia.

TABLE 51.—*Rye crop of countries named, 1908-1912.*

Country.	1908	1909	1910	1911	1912
<b>NORTH AMERICA.</b>					
United States.....	<i>Bushels.</i> 31,851,000	<i>Bushels.</i> 29,520,000	<i>Bushels.</i> 34,897,000	<i>Bushels.</i> 33,119,000	<i>Bushels.</i> 35,664,000
Canada:					
Quebec.....	325,000	335,000	308,000	321,000	296,000
Ontario.....	1,030,000	1,097,000	923,000	1,766,000	1,746,000
Manitoba.....	101,000	75,000	92,000	.....	.....
Saskatchewan.....	41,000	38,000	49,000	.....	.....
Alberta.....	200,000	152,000	162,000	564,000	537,000
Other.....	14,000	18,000	10,000	18,000	15,000
Total Canada.....	1,711,000	1,715,000	1,544,000	2,669,000	2,594,000
Mexico.....	70,000	70,000	70,000	70,000	70,000
Total.....	33,632,000	31,305,000	36,511,000	35,858,000	38,328,000
<b>EUROPE.</b>					
Austria-Hungary:					
Austria.....	113,309,000	117,279,000	112,497,000	105,269,000	119,620,000
Hungary proper.....	45,185,000	44,858,000	49,686,000	50,353,000	54,142,000
Croatia-Slavonia.....	2,520,000	2,393,000	2,318,000	2,674,000	2,531,000
Bosnia-Herzegovina.....	298,000	368,000	394,000	379,000	450,000
Total Austria-Hungary.....	161,312,000	164,898,000	164,895,000	158,675,000	176,743,000
Belgium.....	22,199,000	23,154,000	22,085,000	23,089,000	22,500,000
Bulgaria.....	5,604,000	6,906,000	9,045,000	12,000,000	10,000,000
Denmark.....	19,170,000	18,922,000	19,564,000	19,286,000	18,500,000
Finland.....	11,195,000	12,085,000	11,000,000	10,153,000	12,344,000
France.....	51,703,000	54,934,000	44,064,000	45,894,000	50,936,000
Germany.....	422,688,000	446,763,000	413,802,000	427,776,000	456,600,000
Italy.....	5,000,000	5,032,000	5,439,000	5,297,000	5,285,000
Netherlands.....	15,866,000	17,652,000	15,357,000	16,110,000	16,000,000
Norway.....	869,000	1,011,000	896,000	948,000	1,042,000
Roumania.....	2,640,000	3,090,000	7,885,000	4,989,000	3,583,000
Russia:					
Russia proper.....	673,736,000	783,055,000	750,316,000	642,173,000	.....
Poland.....	77,954,000	86,775,000	83,573,000	95,453,000	.....
Northern Caucasia.....	6,993,000	7,335,000	9,811,000	4,739,000	.....
Total Russia (European).....	758,683,000	877,165,000	843,700,000	742,365,000	1,011,029,000
Servia.....	974,000	1,754,000	1,513,000	1,711,000	1,500,000
Spain.....	26,412,000	34,901,000	27,596,000	28,897,000	18,867,000
Sweden.....	26,052,000	25,728,000	24,154,000	23,825,000	23,323,000
United Kingdom.....	1,776,000	1,954,000	1,800,000	1,750,000	1,500,000
Total.....	1,532,143,000	1,695,949,000	1,612,795,000	1,522,765,000	1,829,752,000
<b>ASIA.</b>					
Russia:					
Central Asia.....	1,326,000	1,498,000	1,011,000	587,000	.....
Siberia.....	22,775,000	18,152,000	22,895,000	19,086,000	.....
Transcaucasia.....	9,000	18,000	22,000	13,000	.....
Total Russia (Asiatic).....	24,110,000	19,668,000	23,928,000	19,686,000	32,953,000
Total.....	24,110,000	19,668,000	23,928,000	19,686,000	32,953,000
<b>AUSTRALASIA.</b>					
Australia:					
Queensland.....	1,000	1,000	3,000	2,000	.....
New South Wales.....	56,000	51,000	66,000	59,000	.....
Victoria.....	22,000	33,000	27,000	30,000	.....
South Australia.....	.....	.....	15,000	8,000	.....
Western Australia.....	5,000	4,000	10,000	6,000	.....
Tasmania.....	15,000	18,000	18,000	24,000	.....
Total Australia.....	99,000	107,000	139,000	129,000	58,000
New Zealand.....	73,000	94,000	100,000	109,000	90,000
Total Australasia.....	172,000	201,000	239,000	238,000	148,000
Grand total.....	1,590,057,000	1,747,123,000	1,673,473,000	1,578,547,000	1,901,181,000

TABLE 52.—Total production of rye in countries named in Table 51, 1895–1912.

Year.	Production.	Year.	Production.	Year.	Production.	Year.	Production.
	<i>Bushels.</i>		<i>Bushels.</i>		<i>Bushels.</i>		<i>Bushels.</i>
1895.....	1,468,212,000	1900.....	1,557,634,000	1905.....	1,495,751,000	1910.....	1,673,473,000
1896.....	1,499,250,000	1901.....	1,416,022,000	1906.....	1,433,395,000	1911.....	1,578,547,000
1897.....	1,300,645,000	1902.....	1,647,845,000	1907.....	1,538,778,000	1912.....	1,901,181,000
1898.....	1,461,171,000	1903.....	1,659,961,000	1908.....	1,590,057,000		
1899.....	1,583,179,000	1904.....	1,742,112,000	1909.....	1,747,123,000		

TABLE 53.—Average yield of rye in countries named, bushels per acre, 1890–1912.

Year.	United States.	Russia (European.) <sup>1</sup>	Germany. <sup>1</sup>	Austria. <sup>1</sup>	Hungary proper. <sup>1</sup>	France. <sup>2</sup>	Ireland. <sup>3</sup>
Average (1890–1899).....	13.9	10.4	20.9	16.1	.....	17.6	25.2
Average (1900–1909).....	15.7	11.5	25.6	19.0	17.6	17.1	27.5
1903.....	15.4	12.2	26.2	18.2	18.6	18.1	26.9
1904.....	15.2	13.7	26.3	19.3	17.0	16.6	26.0
1905.....	16.5	10.1	24.9	20.2	19.4	18.5	27.0
1906.....	16.7	8.8	25.1	19.9	19.8	16.3	27.6
1907.....	16.4	10.8	25.8	18.9	16.0	18.2	27.0
1908.....	16.4	11.0	28.0	22.0	17.5	16.8	29.2
1909.....	13.4	12.6	28.8	22.3	17.8	18.1	30.8
1910.....	16.0	12.3	27.1	21.4	18.9	14.7	30.3
1911.....	15.6	<sup>3</sup> 10.4	28.3	20.8	18.7	16.5	28.9
1912.....	16.8	<sup>3</sup> 14.3	29.5	23.3	19.2	17.0	30.7
Average (1903–1912).....	15.8	11.6	27.0	20.6	18.3	17.1	28.4

<sup>1</sup> Bushels of 56 pounds.

<sup>2</sup> Winchester bushels.

<sup>3</sup> Includes Asiatic Russia.

TABLE 54.—Acreage, production, value, and exports of rye, United States, 1849-1912.

Year.	Acreage.	Average yield per acre.	Production.	Average farm price per bushel Dec. 1.	Farm value Dec. 1.	Chicago cash price per bushel, No. 2.				Domestic exports, including rye flour, fiscal year beginning July 1.
						December.		May of following year.		
						Low.	High.	Low.	High.	
	<i>Acres.</i>	<i>Bush.</i>	<i>Bushels.</i>	<i>Cents.</i>	<i>Dollars.</i>	<i>Cts.</i>	<i>Cts.</i>	<i>Cts.</i>	<i>Cts.</i>	<i>Bushels.</i>
1849 <sup>1</sup>			14, 189, 000							
1859 <sup>1</sup>			21, 101, 000							
1866	1, 548, 000	13.5	20, 865, 000	82.2	17, 150, 000	.....	.....	142	150	234, 971
1867	1, 689, 000	13.7	23, 184, 000	100.4	23, 281, 000	132	117	173	185	564, 901
1868	1, 651, 000	13.6	22, 505, 000	94.9	21, 349, 000	106½	158	100	115½	92, 869
1869	1, 658, 000	13.6	22, 528, 000	77.0	17, 342, 000	66	77½	78	83½	199, 450
1869 <sup>1</sup>			16, 919, 000							
1870	1, 176, 000	13.2	15, 474, 000	73.2	11, 327, 000	67	74	81	91	87, 174
1871	1, 070, 000	14.4	15, 366, 000	71.1	10, 928, 000	62	63½	75	93	832, 689
1872	1, 049, 000	14.2	14, 889, 000	67.6	10, 071, 000	57½	70	68½	70	611, 749
1873	1, 150, 000	13.2	15, 142, 000	70.3	10, 638, 000	70	81	91	102	1, 923, 404
1874	1, 117, 000	13.4	14, 991, 000	77.4	11, 610, 000	93	99½	103	107½	267, 058
1875	1, 360, 000	13.0	17, 722, 000	67.1	11, 894, 000	67	68½	61½	70½	589, 159
1876	1, 468, 000	13.9	20, 375, 000	61.4	12, 505, 000	65½	73	70	92½	2, 234, 856
1877	1, 413, 000	15.0	21, 170, 000	57.6	12, 202, 000	55½	56½	54	60	4, 249, 684
1878	1, 623, 000	15.9	25, 843, 000	52.5	13, 566, 000	44	44½	47	52	4, 877, 821
1879	1, 625, 000	14.5	23, 639, 000	65.6	15, 507, 000	73½	81	73½	85	2, 943, 394
1879 <sup>1</sup>	1, 842, 000	10.8	19, 822, 000							
1880	1, 768, 000	13.9	24, 541, 000	75.6	18, 565, 000	82	91½	115	118	1, 955, 155
1881	1, 789, 000	11.6	20, 705, 000	93.3	19, 327, 000	96½	98	77	83	1, 003, 609
1882	2, 228, 000	13.4	29, 960, 000	61.5	18, 439, 000	57	58½	62	67	2, 206, 212
1883	2, 315, 000	12.1	28, 059, 000	58.1	16, 301, 000	56½	60	60½	62½	6, 247, 590
1884	2, 344, 000	12.2	28, 640, 000	51.9	14, 857, 000	51	52	68	73	2, 974, 350
1885	2, 129, 000	10.2	21, 756, 000	57.9	12, 595, 000	58½	61	58	61	216, 699
1886	2, 130, 000	11.5	24, 489, 000	53.8	13, 181, 000	53	54½	54½	56½	377, 302
1887	2, 053, 000	10.1	20, 693, 000	54.5	11, 283, 000	55	61½	63	68	94, 827
1888	2, 365, 000	12.0	28, 415, 000	58.8	16, 722, 000	50	52	39	41½	309, 266
1889	2, 171, 000	13.1	28, 420, 000	42.3	12, 010, 000	44	45½	49½	54	2, 280, 975
1889 <sup>1</sup>	2, 172, 000	13.1	28, 421, 000							
1890	2, 142, 000	12.0	25, 807, 000	62.9	16, 230, 000	64½	68½	83	92	358, 263
1891	2, 176, 000	14.6	31, 752, 000	77.4	24, 589, 000	86	92	70½	79	12, 068, 628
1892	2, 164, 000	12.9	27, 979, 000	54.2	15, 160, 000	46	51	50½	62	1, 493, 924
1893	2, 038, 000	13.0	26, 555, 000	51.3	13, 612, 000	45	47½	44½	48	249, 152
1894	1, 945, 000	13.7	26, 728, 000	50.1	13, 395, 000	47½	49	62½	67	32, 045
1895	1, 890, 000	14.4	27, 210, 000	44.0	11, 965, 000	32	35½	33	36½	1, 011, 128
1896	1, 831, 000	13.3	24, 369, 000	40.9	9, 961, 000	37	42½	32½	35½	8, 575, 663
1897	1, 704, 000	16.1	27, 363, 000	44.7	12, 240, 000	45½	47	48	75	15, 562, 035
1898	1, 643, 000	15.6	25, 668, 000	46.3	11, 875, 000	52½	55½	56½	62	10, 169, 822
1899	1, 659, 000	14.4	23, 962, 000	51.0	12, 214, 000	49	52	53	56½	2, 382, 012
1899 <sup>1</sup>	2, 054, 000	12.4	25, 569, 000							
1900	1, 591, 000	15.1	23, 996, 000	51.2	12, 295, 000	45½	49½	51½	54	2, 345, 512
1901	1, 988, 000	15.3	30, 345, 000	55.7	16, 910, 000	59	65½	54½	58	2, 712, 077
1902	1, 979, 000	17.0	33, 681, 000	50.8	17, 081, 000	48	49½	48	50½	5, 445, 273
1903	1, 907, 000	15.4	29, 363, 000	54.5	15, 994, 000	50½	52½	69½	78	784, 068
1904	1, 793, 000	15.2	27, 242, 000	68.8	18, 748, 000	73	75	70	84	29, 749
1905	1, 730, 000	16.5	28, 486, 000	61.1	17, 414, 000	64	68	58	62	1, 387, 826
1906	2, 002, 000	16.7	33, 375, 000	58.9	19, 671, 000	61	65	69	87½	769, 717
1907	1, 826, 000	16.4	31, 566, 000	73.1	23, 068, 000	75	82	79	86	2, 444, 588
1908	1, 948, 000	16.4	31, 851, 000	73.6	23, 455, 000	75	77½	83	90	1, 295, 701
1909	2, 006, 000	16.1	32, 239, 000	73.9	23, 809, 000	72	80	74	80	242, 262
1909 <sup>1</sup>	2, 196, 000	13.4	29, 520, 000							
1910 <sup>2</sup>	2, 185, 000	16.0	34, 897, 000	71.5	24, 953, 000	80	82	90	113	40, 123
1911 <sup>2</sup>	2, 127, 000	15.6	33, 119, 000	83.2	27, 557, 000	91	94	90	95½	31, 384
1912	2, 117, 000	16.8	35, 664, 000	66.3	23, 636, 000	58	64			

<sup>1</sup> Census figures.<sup>2</sup> Figures adjusted to census basis.



TABLE 57.—Yield per acre, price per bushel, and value per acre of rye, by States.

State and division.	Yield per acre.							Farm price per bushel.										Value per acre, 1912. <sup>1</sup>	
	10-year averages.							10-year averages for Dec. 1.					Quarterly, 1912.						
	1870-1879	1880-1889	1890-1899	1900-1909	1910	1911	1912	1870-1879	1880-1889	1890-1899	1900-1909	Dec. 1, 1910.	Dec. 1, 1911.	Mar. 1.	June 1.	Sept. 1.	Dec. 1.		
	Bu.	Bu.	Bu.	Bu.	Bu.	Bu.	Bu.	Cts.	Cts.	Cts.	Cts.	Cts.	Cts.	Cts.	Cts.	Cts.	Cts.		Dols.
Vermont.....	16.8	14.3	15.7	16.8	17.5	22.5	20.0	90	79	69	75	85	95	104	90	95	95	100	18.00
Massachusetts.....	15.6	13.9	17.3	15.8	17.0	16.0	18.5	89	83	74	82	94	95	104	90	96	100	18.50	
Connecticut.....	14.6	13.5	15.7	17.6	20.0	18.5	17.5	95	78	68	76	86	93	93	100	97	92	16.10	
New York.....	13.8	12.0	15.5	16.1	18.3	16.7	16.5	76	69	59	68	74	89	90	93	81	76	12.54	
New Jersey.....	13.4	10.9	14.2	16.4	18.0	16.4	17.5	77	70	60	67	77	83	88	89	79	79	13.82	
Pennsylvania.....	13.8	10.6	15.0	16.1	17.0	15.1	17.5	75	67	56	66	73	80	85	90	78	77	13.48	
North Atlantic.....	13.9	11.3	14.9	16.2	17.5	15.8	17.3	77.4	69.6	59.5	67.1	74.3	83.4	87.2	90.8	79.5	77.4	13.36	
Delaware.....	11.7	8.3	8.2	14.0	15.5	15.0	14.0	71	65	68	69	69	95	80	88	81	81	11.34	
Maryland.....	12.2	10.4	12.8	14.8	16.1	14.5	15.5	70	67	57	66	75	86	81	90	78	80	12.40	
Virginia.....	10.4	6.9	9.4	12.3	13.5	11.5	12.5	63	68	57	71	80	89	84	91	86	85	10.62	
West Virginia.....	12.7	8.4	10.5	11.7	12.9	11.0	13.0	72	70	62	74	90	90	88	89	85	84	10.92	
North Carolina.....	9.2	5.7	7.6	9.4	10.0	10.0	9.3	77	83	72	88	101	100	101	106	101	105	9.76	
South Carolina.....	6.5	4.6	6.2	8.4	10.0	10.0	9.5	133	109	100	121	146	145	148	157	145	145	13.78	
Georgia.....	7.6	5.4	6.7	8.0	10.4	9.5	9.2	138	109	100	115	140	138	150	159	138	140	12.88	
South Atlantic.....	10.0	6.8	9.1	11.3	12.5	11.4	11.9	56.2	77.0	66.0	79.4	89.7	95.4	92.2	98.5	91.2	92.2	10.94	
Ohio.....	13.6	12.4	14.9	17.1	16.5	15.5	15.5	66	62	52	64	72	85	84	89	80	75	11.62	
Indiana.....	14.2	11.5	14.1	15.2	15.8	13.7	14.5	63	61	49	61	68	80	79	83	72	68	9.86	
Illinois.....	16.8	15.2	15.1	17.6	17.4	16.8	16.0	52	56	48	61	71	81	81	87	72	70	11.20	
Michigan.....	14.8	12.3	13.5	15.1	15.3	14.6	13.3	65	62	49	60	68	85	85	86	70	65	8.64	
Wisconsin.....	15.5	13.6	14.8	17.0	16.0	17.0	18.3	56	56	47	60	71	84	82	82	68	61	11.16	
N. C. E. Miss. R.....	15.7	14.2	14.6	16.3	15.8	15.6	15.6	74.3	57.1	48.1	60.3	69.6	84.0	83.2	84.4	70.1	64.3	10.04	
Minnesota.....	18.6	14.9	17.4	19.1	17.0	18.7	23.0	50	50	42	54	64	78	79	79	53	50	11.50	
Iowa.....	17.4	13.2	16.6	18.0	18.5	18.0	19.0	45	48	43	53	64	77	78	83	55	62	11.78	
Missouri.....	15.4	11.9	12.9	14.8	15.0	14.1	14.8	56	55	50	64	75	84	81	90	83	80	11.84	
North Dakota.....	14.4	14.6	16.4	8.5	16.6	18.0	18.0	49	38	51	63	76	75	83	54	47	8.46		
South Dakota.....	14.3	12.3	13.7	10.7	17.0	10.0	19.5	49	38	49	61	76	75	82	62	52	10.14		
Nebraska.....	17.6	13.7	13.8	16.8	16.0	13.0	16.0	44	41	39	49	60	75	72	80	60	56	8.96	
Kansas.....	18.0	14.4	10.9	14.2	14.0	11.0	15.9	50	43	44	57	73	81	89	78	68	10.81		
N. C. W. Miss. R.....	17.4	13.8	13.9	17.0	16.2	16.9	20.5	47.3	46.1	42.0	52.3	64.1	77.7	77.8	80.4	55.7	52.8	10.82	
Kentucky.....	11.7	9.2	11.7	13.6	13.0	12.0	13.0	68	68	62	74	85	94	92	98	87	88	11.44	
Tennessee.....	9.9	6.3	8.6	11.7	11.0	11.9	11.5	78	84	65	79	92	99	102	98	95	98	11.27	
Alabama.....	9.8	5.7	9.1	10.3	12.0	10.0	11.5	130	110	101	114	120	125	123	128	134	15.41		
Texas.....	16.0	10.4	9.5	13.0	11.5	10.0	16.6	103	86	74	89	103	107	100	104	91	110	18.26	
Oklahoma.....	12.8	7.3	9.4	10.6	12.0	10.0	10.5	105	88	72	87	98	90	96	105	105	11.02		
Arkansas.....	12.8	7.3	9.4	10.6	12.0	10.0	10.5	105	88	72	87	98	90	96	105	105	11.02		
South Central.....	11.4	8.2	10.4	12.6	12.2	11.6	12.4	72.8	73.1	65.0	78.8	88.4	97.5	96.0	98.0	90.2	93.7	11.65	
Montana.....	22.2	16.8	17.1	18.3	14.0	12.0	19.5	98	74	56	62	67	72	86	65	75	60	14.10	
Wyoming.....	22.2	16.8	17.1	18.3	14.0	12.0	19.5	98	74	56	62	67	72	86	65	75	60	14.10	
Colorado.....	22.2	16.8	17.1	18.3	14.0	12.0	19.5	98	74	56	62	67	72	86	65	75	60	14.10	
Utah.....	22.2	16.8	17.1	18.3	14.0	12.0	19.5	98	74	56	62	67	72	86	65	75	60	14.10	
Idaho.....	22.2	16.8	17.1	18.3	14.0	12.0	19.5	98	74	56	62	67	72	86	65	75	60	14.10	
Washington.....	22.2	16.8	17.1	18.3	14.0	12.0	19.5	98	74	56	62	67	72	86	65	75	60	14.10	
Oregon.....	22.3	15.5	12.9	15.7	15.1	19.5	16.0	84	73	65	81	100	90	95	95	76	70	11.20	
California.....	20.0	10.5	13.5	12.8	17.0	17.0	17.6	104	79	68	77	86	85	99	99	99	90	15.84	
Far Western.....	19.9	11.4	14.0	14.2	16.5	17.6	18.7	99.0	76.2	64.7	75.2	79.5	79.2	86.3	83.2	69.9	64.4	12.06	
United States.....	14.1	12.0	14.0	16.0	16.0	15.6	16.8	66.4	60.8	52.3	62.2	71.5	83.2	84.0	86.1	70.8	66.3	11.16	

<sup>1</sup> Basis, Dec. 1 price.

<sup>2</sup> The Territories.

TABLE 58.—Wholesale price of rye per bushel, 1899–1912.

Date.	Philadelphia.		Cincinnati.		Chicago.		Duluth.		San Francisco (per 100 lbs.).	
	Low.	High.	No. 2.		No. 2.		Low.	High.	Low.	High.
			Low.	High.	Low.	High.				
	Cents.	Cents.	Cents.	Cents.	Cents.	Cents.	Cents.	Cents.	Dolls.	Dolls.
1899			56	68	49	62	47	59½		
1900			51½	67	44½	60½	46	60½		
1901	58	71½	45	73	46½	65½	46½	62½	0.75	0.87½
1902	54	71	51	71½	48	67½	46	64	1.15	1.15
1903	56	68½	54	63	48	60	48	55½	1.10	1.30
1904	65	96	61	87	51	81	54½	80	1.25	1.47½
1905	63	90½	56	87	57½	84	55½	78	1.40	1.75
1906	55½	67	58	72½	55½	68	53	61		
1907	75	100	68	93	60	91½	57	86	1.35	1.52½
1908	80	95	78	89	72	87	60	80	1.35	1.52½
1909.										
January	90	95	78	82	74	77½	67	71	1.55	1.70
February	90	95	80	82	75½	79½	67	74	1.65	1.85
March	88	95	81	84	79	81	71	75	1.75	1.85
April	87	88	82	90	80	87	72	83		
May	85	87	88	92	83	90	80	88		
June	85	87	90	92	81	91	72	88		
July	75	80	75	90	74	83½	69	76		
August	75	82	70	85	67	76½	62	72	1.70	1.80
September	82	85	70	77½	70	74	62	67	1.80	1.85
October	85	86	75	78	71	75	64	71		
November	85	86	76	80	73	77	67	71	2.00	2.05
December	86	87	77	81	72	80	68	74		
Year	75	95	70	92	67	91	62	88	1.55	2.05
1910.										
January	90	92	79	87	79	82	71½	78½	Nominal.	
February	90	92	84	86	80	82	75	78½	1.97½	2.00
March	87	89	83	86½	78	80	72	78	1.97½	2.00
April	85	87	82	86	77½	80½	70	75	1.85	1.95
May	83	85	81	84	74	80	68	73	1.70	1.85
June	83	85	80	83	74	77	67	70	1.55	1.75
July	75	77	78	83	74	80	67	70	1.55	1.70
August	77	78	73	80	72	78	67	75	1.60	1.70
September	78	80	73	77	72½	74½	68	70	1.60	1.70
October	80	81	75	81	74½	77½	68	74	1.50	1.65
November	80	81	80	85	77	80½	71½	75	1.50	1.55
December	81	85½	83	87	80	82	71½	76	1.50	1.60
Year	75	92	73	87	72	82	67	78½	1.50	2.00
1911.										
January	88	90	85	88	81	86	74	79	1.50	1.60
February	78	80	85	88	80	84	74	78	1.50	1.60
March	79	82	86	90½	85	93	77	84	1.40	1.60
April	82	85	98	98	90	100	82	88	1.40	1.50
May	85	90	95	115	90	113	86	100	1.42½	1.50
June	90	91	88	97	87	93	81	88	1.45	1.60
July	91	92	79	90	80½	87	72	83	1.50	1.60
August	92	92	81	92	82½	87½	76	84	1.50	1.60
September	92	107	90	101	85½	96½	79½	91½	1.47½	1.52½
October	100	107	98	100	95½	98	89½	93½	1.47½	1.57½
November	100	106	94	100	90	100	83	92	1.50	1.57½
December	100	105	94	98	91	94	83½	88	1.50	1.57½
Year	78	107	79	101	80	113	72	100	1.40	1.60
1912.										
January	100	105	94	100	92	96	86	91½	1.47½	1.55
February	100	105	94	97	89½	94	84	89	1.47½	1.52½
March	99	103	93	96½	89½	92	85	90	1.50	1.60
April	100	104	93	97½	91	96½	84	91	1.52½	1.72½
May	99	103	91	98	90	95½	84	91	1.62½	1.72½
June	95	103	78	93	75	90	66	84	1.62½	1.72½
July	75	80	75	81	71½	76	66	70	1.40	1.72½
August	75	85	75	78	68	75	63	66	1.40	1.50
September	75	85	73	77	66½	71	58	64	1.42½	1.50
October	75	80	72	77	67	71	60	65½	1.40	1.50
November	73	78	62	72	59½	69	53	61½	1.45	1.50
December	68	73	65	68	58	64	53	57	1.45	1.47½
Year	68	105	62	100	58	96½	53	91½	1.40	1.72½



TABLE 59.—Farm price of rye per bushel on first of each month, 1911-12.

Month.	United States.		North Atlantic States.		South Atlantic States.		N. Central States East of Miss. R.		N. Central States West of Miss. R.		South Central States.		Far Western States.	
	1912	1911	1912	1911	1912	1911	1912	1911	1912	1911	1912	1911	1912	1911
January.....	Cts. 82.7	Cts. 73.3	Cts. 83.9	Cts. 76.1	Cts. 89.7	Cts. 87.1	Cts. 82.7	Cts. 71.7	Cts. 78.3	Cts. 66.8	Cts. 96.0	Cts. 85.0	Cts. 83.4	Cts. 76.1
February.....	84.4	73.1	85.3	74.5	93.7	85.8	84.0	72.3	81.2	67.8	95.8	83.2	82.4	74.6
March.....	84.0	71.9	87.2	73.1	92.2	83.5	83.2	71.4	77.8	66.2	96.0	80.8	86.3	75.9
April.....	85.1	75.4	87.4	74.5	92.7	83.8	84.2	75.1	80.6	68.2	97.2	82.5	89.1	98.6
May.....	84.6	75.8	88.3	75.1	98.9	83.9	85.1	77.4	74.1	70.2	94.2	81.8	86.8	78.0
June.....	86.1	77.9	90.8	76.6	98.5	85.5	84.4	79.2	80.4	74.3	98.0	86.2	83.2	81.6
July.....	83.6	76.9	90.2	77.9	93.2	87.2	82.3	76.7	75.0	72.4	93.8	84.5	85.5	76.5
August.....	77.9	75.5	86.2	79.1	94.3	86.5	76.7	71.9	64.9	70.3	91.0	87.0	81.5	85.5
September.....	70.8	76.9	79.5	78.0	91.2	87.6	70.1	76.1	55.7	73.9	90.2	92.2	69.9	74.0
October.....	70.1	79.7	78.6	80.4	93.7	86.5	68.4	80.2	57.0	76.4	94.6	95.2	64.4	74.1
November.....	68.8	83.1	77.9	81.7	92.7	93.4	66.7	85.9	55.9	78.5	93.2	99.5	62.9	75.0
December.....	66.3	83.2	77.4	83.4	92.2	95.4	64.3	84.0	52.8	77.7	93.7	97.5	64.4	79.2

## BUCKWHEAT.

TABLE 60.—Acreage, production, and value of buckwheat in the United States, 1849-1912.

Year.	Acreage sown and harvested.		Average yield per acre.	Production.	Average farm price per bushel Dec. 1.	
	Acres.	Bushels.			Cents.	Dollars.
1849 <sup>1</sup> .....				Bushels. 8,957,000		
1859 <sup>1</sup> .....				17,572,000		
1866.....	1,046,000	21.8		22,792,000	67.6	15,413,000
1867.....	1,228,000	17.4		21,359,000	78.7	16,812,000
1868.....	1,114,000	17.8		19,864,000	78.0	15,490,000
1869.....	1,029,000	16.9		17,431,000	71.9	12,535,000
1869 <sup>1</sup> .....				9,822,000		
1870.....	537,000	18.3		9,842,000	70.5	6,937,000
1871.....	414,000	20.1		8,329,000	74.5	6,208,000
1872.....	448,000	18.1		8,134,000	73.5	5,979,000
1873.....	454,000	17.3		7,838,000	75.0	5,879,000
1874.....	453,000	17.7		8,017,000	72.9	5,844,000
1875.....	576,000	17.5		10,082,000	62.0	6,255,000
1876.....	666,000	14.5		9,669,000	66.6	6,436,000
1877.....	650,000	15.7		10,177,000	66.9	6,808,000
1878.....	673,000	18.2		12,247,000	52.6	6,441,000
1879.....	640,000	20.5		13,140,000	59.8	7,856,000
1879 <sup>1</sup> .....	848,000	13.9		11,817,000		
1880.....	823,000	17.8		14,618,000	59.4	8,682,000
1881.....	829,000	11.4		9,486,000	86.5	8,206,000
1882.....	847,000	13.0		11,019,000	73.0	8,039,000
1883.....	857,000	8.9		7,669,000	82.2	6,304,000
1884.....	879,000	12.6		11,116,000	58.9	6,549,000
1885.....	914,000	13.8		12,626,000	55.9	7,057,000
1886.....	918,000	12.9		11,869,000	54.5	6,465,000
1887.....	911,000	11.9		10,844,000	56.5	6,122,000
1888.....	913,000	13.2		12,050,000	63.3	7,628,000
1889.....	837,000	14.5		12,110,000	50.5	6,113,000
1889 <sup>1</sup> .....	837,000	14.5		12,110,000		
1890.....	845,000	14.7		12,433,000	57.4	7,133,000
1891.....	849,000	15.0		12,761,000	57.0	7,272,000
1892.....	861,000	14.1		12,143,000	51.8	6,296,000
1893.....	816,000	14.9		12,132,000	58.3	7,074,000
1894.....	789,000	16.1		12,668,000	55.6	7,040,000
1895.....	763,000	20.1		15,341,000	45.2	6,936,000
1896.....	755,000	18.7		14,090,000	39.2	5,522,000
1897.....	718,000	20.9		14,997,000	42.1	6,319,000
1898.....	678,000	17.3		11,722,000	45.0	5,271,000

<sup>1</sup> Census figures.

TABLE 60.—*Acreage, production, and value of buckwheat in the United States—Con.*

Year.	Acreage sown and harvested.	Average yield per acre.	Production.	Average farm price per bushel Dec. 1.	Farm value Dec. 1.
	<i>Acres.</i>	<i>Bushels.</i>	<i>Bushels.</i>	<i>Cents.</i>	<i>Dollars.</i>
1899.....	670,000	16.6	11,094,000	55.7	6,184,000
1899 <sup>1</sup> .....	807,000	13.9	11,234,000	.....	.....
1900.....	638,000	15.0	9,567,000	55.8	5,341,000
1901.....	811,000	18.6	15,126,000	56.3	8,523,000
1902.....	805,000	18.1	14,530,000	59.6	8,655,000
1903.....	804,000	17.7	14,244,000	60.7	8,651,000
1904.....	794,000	18.9	15,008,000	62.2	9,331,000
1905.....	760,000	19.2	14,585,000	58.7	8,565,000
1906.....	789,000	18.6	14,642,000	59.6	8,727,000
1907.....	800,000	17.9	14,290,000	69.8	9,975,000
1908.....	803,000	19.8	15,874,000	75.6	12,004,000
1909.....	834,000	20.9	17,438,000	69.9	12,188,000
1909 <sup>1</sup> .....	878,000	16.9	14,849,000	.....	.....
1910 <sup>2</sup> .....	860,000	20.5	17,598,000	66.1	11,636,000
1911 <sup>2</sup> .....	833,000	21.1	17,549,000	72.6	12,735,000
1912.....	841,000	22.9	19,249,000	66.1	12,720,000

<sup>1</sup> Census figures.

<sup>2</sup> Figures adjusted to census basis.

TABLE 61.—*Acreage, production, and value of buckwheat in the United States in 1912.*

State and division.	Acreage sown and harvested.	Production.	Farm value Dec. 1.	State and division.	Acreage.	Production.	Farm value Dec. 1.
	<i>Acres.</i>	<i>Bushels.</i>	<i>Dollars.</i>		<i>Acres.</i>	<i>Bushels.</i>	<i>Dollars.</i>
Maine.....	14,000	412,000	288,000	Michigan.....	64,000	1,088,000	707,000
New Hampshire.....	1,000	31,000	22,000	Wisconsin.....	17,000	289,000	191,000
Vermont.....	8,000	240,000	173,000	N. C. E. of Miss. R.....	111,000	1,970,000	1,324,000
Massachusetts.....	2,000	42,000	36,000	Minnesota.....	6,000	126,000	82,000
Connecticut.....	3,000	62,000	55,000	Iowa.....	7,000	133,000	100,000
New York.....	277,000	6,593,000	4,220,000	Missouri.....	2,000	30,000	28,000
New Jersey.....	12,000	264,000	190,000	Nebraska.....	1,000	18,000	16,000
Pennsylvania.....	306,000	7,405,000	4,739,000	Kansas.....	1,000	16,000	12,000
N. Atlantic.....	623,000	15,049,000	9,723,000	N. C. W. of Miss. R.....	17,000	323,000	238,000
Delaware.....	4,000	64,000	42,000	Tennessee.....	3,000	54,000	42,000
Maryland.....	12,000	210,000	149,000	S. Central.....	3,000	54,000	42,000
Virginia.....	24,000	516,000	387,000	United States...	841,000	19,249,000	12,720,000
West Virginia.....	37,000	888,000	666,000				
North Carolina.....	10,000	175,000	149,000				
S. Atlantic.....	87,000	1,853,000	1,393,000				
Ohio.....	21,000	410,000	287,000				
Indiana.....	5,000	95,000	69,000				
Illinois.....	4,000	88,000	70,000				

TABLE 62.—*Condition of buckwheat crop, United States, on first of months named, 1892-1912.*

Year.	Aug.	Sept.	When harvested.	Year.	Aug.	Sept.	When harvested.	Year.	Aug.	Sept.	When harvested.
	<i>P. ct.</i>	<i>P. ct.</i>	<i>P. ct.</i>		<i>P. ct.</i>	<i>P. ct.</i>	<i>P. ct.</i>		<i>P. ct.</i>	<i>P. ct.</i>	<i>P. ct.</i>
1892.....	92.9	89.0	85.6	1899.....	93.2	75.2	70.2	1906.....	93.2	91.2	84.9
1893.....	88.8	77.5	73.5	1900.....	87.9	80.5	72.8	1907.....	91.9	77.4	80.1
1894.....	82.3	69.2	72.0	1901.....	91.1	90.9	90.5	1908.....	89.4	87.8	81.6
1895.....	85.2	87.5	84.8	1902.....	91.4	86.4	80.5	1909.....	86.4	81.1	79.5
1896.....	96.0	87.8	86.0	1903.....	93.9	91.0	83.0	1910.....	87.9	82.3	81.7
1897.....	94.9	95.1	90.8	1904.....	92.8	91.5	88.7	1911.....	82.9	83.8	81.4
1898.....	87.2	88.8	76.2	1905.....	92.6	91.8	91.6	1912.....	88.4	91.6	89.2

TABLE 63.—Yield per acre, price per bushel, and value per acre of buckwheat, by States.

State and division.	Yield per acre.							Farm price per bushel.										Value per acre, 1912. <sup>1</sup>
	10-year averages.				1910	1911	1912	10-year averages for Dec. 1.				Dec. 1, 1910.	Dec. 1, 1911.	Quarterly, 1912.				
	1870-1879	1880-1889	1890-1899	1900-1909				1870-1879	1880-1889	1890-1899	1900-1909			Mar. 1.	June 1.	Sept. 1.	Dec. 1.	
Maine.....	23.2	18.4	29.2	29.8	32.5	30.0	29.4	63	56	50	59	68	70	77	100	70	70	20.58
New Hampshire.....	19.0	18.1	22.4	21.8	31.0	27.3	31.0	62	61	56	67	62	81	75	78	60	72	22.32
Vermont.....	21.5	18.4	24.8	23.1	24.0	24.3	30.0	61	59	49	60	70	85	89	104	85	72	21.60
Massachusetts.....	13.6	14.1	18.4	17.8	22.0	21.0	21.0	73	70	66	71	85	89	105	75	90	85	17.85
Connecticut.....	16.5	12.1	16.0	17.3	19.5	19.0	20.5	83	69	63	75	83	95	98	100	103	88	18.04
New York.....	18.4	13.7	17.0	18.8	23.0	21.3	23.8	66	62	50	63	65	73	79	90	78	64	15.23
New Jersey.....	17.6	11.6	16.7	19.4	21.5	20.0	22.0	76	71	56	65	69	75	79	100	76	72	15.84
Pennsylvania.....	18.7	13.1	16.9	18.3	19.5	21.9	24.2	70	66	50	62	62	69	74	79	74	64	15.49
N. Atlantic.....	18.6	13.7	17.7	19.1	21.6	21.8	24.2	67.8	63.3	50.3	62.4	64.1	71.4	76.8	85.5	76.0	64.6	15.61
Delaware.....	19.6	12.9	16.7	18.1	20.5	19.0	16.0	75	65	50	60	65	65	70	100	....	66	10.56
Maryland.....	17.4	13.0	14.7	17.5	18.5	20.0	17.5	70	68	57	64	66	67	70	....	....	71	14.42
Virginia.....	15.3	10.7	13.2	17.3	18.0	16.0	21.5	61	65	55	64	77	70	....	93	83	75	16.12
West Virginia.....	17.1	10.1	17.1	19.3	23.0	24.0	24.0	69	67	58	68	77	85	76	79	78	75	18.00
North Carolina.....	15.2	9.5	13.9	15.1	19.0	19.0	17.5	56	63	52	68	80	80	75	90	90	85	14.88
S. Atlantic.....	16.6	10.7	15.6	17.9	20.4	20.4	21.3	66.4	66.2	57.1	65.8	75.5	77.8	74.7	85.0	80.9	75.2	16.01
Ohio.....	14.1	11.1	15.4	17.5	18.0	21.0	19.5	77	73	57	67	75	78	77	80	81	70	13.65
Indiana.....	16.1	10.4	14.8	16.0	17.7	18.3	19.0	69	73	57	68	70	74	....	....	....	73	13.87
Illinois.....	14.6	10.6	13.2	16.3	20.0	18.1	22.0	72	72	58	75	90	95	....	97	106	80	17.60
Michigan.....	16.0	13.2	14.4	14.4	15.3	18.0	17.0	62	65	48	58	62	71	75	79	72	65	11.05
Wisconsin.....	15.8	10.6	14.2	14.9	14.0	17.5	17.0	59	63	49	64	75	75	77	77	76	66	11.22
N. C. E. Miss R.....	15.4	11.4	14.4	15.2	15.9	18.4	17.7	65.2	66.9	50.3	62.6	68.3	73.8	75.7	79.5	75.6	67.2	11.93
Minnesota.....	16.2	11.0	13.8	15.0	16.0	18.0	21.0	65	64	50	62	72	76	....	78	67	65	13.65
Iowa.....	17.6	11.2	14.4	14.5	14.9	17.5	19.0	67	69	57	73	83	90	111	100	110	75	14.25
Missouri.....	17.9	11.4	13.6	15.2	16.5	10.0	15.0	62	68	63	78	87	105	....	104	102	95	14.25
Nebraska.....	19.7	10.1	12.1	15.3	20.0	16.0	18.0	73	71	59	72	90	95	172	....	100	90	16.20
Kansas.....	16.3	11.1	10.4	13.9	15.0	12.0	16.0	82	74	75	80	90	98	....	....	....	78	12.48
N. C. W. Miss. R.....	17.1	11.0	13.6	14.9	15.8	16.4	19.0	69.3	68.4	55.6	70.5	80.0	85.8	119.7	89.7	89.5	73.7	14.00
Tennessee.....	14.2	8.4	14.0	15.4	15.0	16.0	18.0	75	66	57	72	86	79	84	89	75	78	14.04
S. Central.....	14.0	8.7	14.2	15.4	15.0	16.0	18.0	75.0	66.3	57.1	72.1	86.0	79.0	84.0	89.0	75.0	78.0	14.04
United States.....	17.8	13.0	16.8	18.5	20.5	21.1	22.9	67.4	64.1	50.7	62.8	66.1	72.6	76.9	84.8	76.6	66.1	15.12

<sup>1</sup> Basis, Dec. 1 price.

TABLE 64.—Farm price of buckwheat per bushel on first of each month, 1911-1912.

Month.	United States.		North Atlantic States.		South Atlantic States.		N. Central States east of Miss. R.		N. Central States west of Miss. R.		South Central States.		Far Western States.	
	1912	1911	1912	1911	1912	1911	1912	1911	1912	1911	1912	1911	1912	1911
January.....	Cts. 73.7	Cts. 65.8	Cts. 73.5	Cts. 65.1	Cts. 69.7	Cts. 69.8	Cts. 73.6	Cts. 65.2	Cts. 81.8	Cts. 95.2	Cts. 80.0	Cts. 77.0	.....	.....
February.....	73.6	64.4	73.1	63.4	74.2	71.4	74.8	65.1	81.1	79.5	80.0	77.0	.....	.....
March.....	76.9	64.1	76.8	62.9	74.7	69.4	75.7	66.3	119.7	87.8	84.0	71.0	.....	.....
April.....	76.9	65.3	77.1	64.1	75.8	73.2	74.8	67.3	98.7	89.5	80.0	70.0	.....	.....
May.....	79.9	65.8	80.0	64.7	80.1	70.4	78.2	68.5	103.1	80.2	85.0	75.0	.....	.....
June.....	84.8	70.1	85.5	69.3	85.0	71.9	79.5	74.6	89.7	81.4	89.0	76.0	.....	.....
July.....	86.2	72.4	87.0	72.1	84.6	72.2	81.4	74.0	94.0	82.2	85.0	76.0	.....	.....
August.....	83.6	76.0	84.3	76.5	82.2	72.9	78.6	70.2	94.0	102.1	85.0	78.0	.....	.....
September.....	76.6	74.0	76.0	74.0	80.9	75.5	75.6	72.0	89.5	76.9	75.0	80.0	.....	.....
October.....	69.7	69.6	68.3	69.3	80.3	71.0	68.7	69.4	82.2	79.6	73.0	81.0	.....	.....
November.....	65.5	73.0	68.3	73.0	75.2	71.6	66.7	72.5	71.9	82.6	71.0	75.0	.....	.....
December.....	66.1	72.6	64.6	71.4	75.2	77.8	67.2	73.8	73.7	85.8	78.0	79.0	.....	.....

## POTATOES.

TABLE 65.—*Potato crop of countries named, 1907-1911.*

[No statistics for Portugal, Egypt, and some other less important potato-growing countries.]

Country.	1907	1908	1909	1910	1911
<b>NORTH AMERICA.</b>					
United States (contiguous).....	<i>Bushels.</i> 298,262,000	<i>Bushels.</i> 278,985,000	<i>Bushels.</i> 389,195,000	<i>Bushels.</i> 349,032,000	<i>Bushels.</i> 292,737,000
<b>Canada:</b>					
Prince Edward Island.....	5,453,000	7,327,000	6,761,000	4,915,000	5,409,000
Nova Scotia.....	8,294,000	7,884,000	9,098,000	6,432,000	4,884,000
New Brunswick.....	5,183,000	11,203,000	12,247,000	7,486,000	8,627,000
Quebec.....	22,911,000	16,680,000	30,853,000	21,271,000	17,435,000
Ontario.....	20,908,000	23,096,000	29,465,000	26,163,000	15,624,000
Manitoba.....	4,150,000	3,807,000	4,118,000	2,838,000	5,122,000
Saskatchewan.....	2,706,000	1,826,000	3,944,000	2,658,000	4,505,000
Alberta.....	2,632,000	1,967,000	2,599,000	2,285,000	4,417,000
Total, Canada.....	72,237,000	73,790,000	99,085,000	74,048,000	66,023,000
Mexico <sup>1</sup> .....	924,000	924,000	924,000	924,000	924,000
Newfoundland.....	2 1,350,000	2 1,350,000	2 1,350,000	2 1,350,000	2 1,533,000
Total.....	372,773,000	355,049,000	490,554,000	425,354,000	361,217,000
<b>SOUTH AMERICA.</b>					
Argentina.....	4 10,000,000	5 10,000,000	45,000,000	18,923,000	6 18,923,000
Chile.....	7 6,532,000	8,063,000	6,404,000	7,863,000	7,440,000
Total.....	16,532,000	18,063,000	51,404,000	26,786,000	26,363,000
<b>EUROPE.</b>					
<b>Austria-Hungary:</b>					
Austria.....	538,789,000	475,860,000	479,616,000	491,126,000	426,406,000
Hungary proper.....	178,168,000	139,469,000	183,530,000	176,974,000	163,038,000
Croatia-Slavonia.....	25,625,000	21,129,000	16,832,000	28,490,000	6 28,490,000
Bosnia-Herzegovina.....	2,949,000	2 2,949,000	2 2,949,000	5,048,000	2,329,000
Total, Austria-Hungary.....	745,531,000	639,407,000	682,927,000	701,638,000	620,263,000
Belgium.....	88,192,000	82,846,000	90,358,000	104,718,000	6 104,718,000
Bulgaria.....	300,000	340,000	323,000	430,000	6 430,000
Denmark.....	24,426,000	29,752,000	24,326,000	30,517,000	29,523,000
Finland.....	18,765,000	16,194,000	17,887,000	15,741,000	22,691,000
France.....	512,229,000	625,021,000	613,041,000	313,189,000	423,573,000
Germany.....	1,673,246,000	1,702,803,000	1,716,143,000	1,597,174,000	1,263,024,000
Greece.....	9 550,000	9 550,000	10 550,000	331,000	6 331,000
Italy.....	11 60,000,000	11 60,000,000	63,273,000	56,563,000	62,140,000
Luxemburg.....	7,295,000	5,878,000	6,099,000	5,085,000	4,461,000
Malta.....	793,000	692,000	372,000	654,000	834,000
Netherlands.....	94,401,000	96,695,000	97,275,000	88,376,000	103,468,000
Norway.....	16,956,000	28,030,000	22,084,000	22,398,000	22,017,000
Roumania.....	3,860,000	4,310,000	3,813,000	4,846,000	5,669,000
<b>Russia:</b>					
Russia proper.....	694,487,000	682,454,000	764,943,000	( <sup>12</sup> )	( <sup>12</sup> )
Poland.....	327,689,000	366,433,000	396,023,000	( <sup>12</sup> )	( <sup>12</sup> )
Northern Caucasus.....	11,932,000	11,248,000	12,520,000	( <sup>12</sup> )	( <sup>12</sup> )
Total Russia (European).....	1,034,108,000	1,060,135,000	1,173,486,000	1,313,973,000	1,143,124,000
Servia.....	876,000	645,000	1,396,000	3,110,000	2,154,000
Spain.....	84,435,000	98,860,000	6 98,860,000	132,905,000	93,089,000
Sweden.....	67,823,000	78,020,000	61,981,000	68,591,000	52,669,000
Switzerland.....	13 47,000,000	49,971,000	44,092,000	46,712,000	6 46,712,000
<b>United Kingdom:</b>					
England.....	78,318,000	101,448,000	98,676,000	92,108,000	99,858,000
Scotland.....	28,540,000	39,146,000	32,889,000	32,790,000	36,407,000
Wales.....	4,301,000	5,663,000	5,615,000	4,915,000	6,547,000
Ireland.....	83,869,000	119,455,000	119,572,000	107,178,000	137,941,000
Total United Kingdom.....	195,028,000	265,712,000	256,752,000	236,991,000	280,753,000
Total.....	4,665,814,000	4,845,861,000	4,975,038,000	4,743,942,000	4,281,643,000

<sup>1</sup> Data for 1906.<sup>2</sup> Estimated from returns for census year 1900.<sup>3</sup> Census returns.<sup>4</sup> Data for 1908.<sup>5</sup> Census shows 19,000 hectares (46,949 acres), yielding 15,000 kilograms per hectare (223 bushels per acre).<sup>6</sup> Year preceding.<sup>7</sup> Data for 1905.<sup>8</sup> Data for 1907.<sup>9</sup> Data for 1909.<sup>10</sup> Unofficial estimate.<sup>11</sup> Average production as unofficially estimated.<sup>12</sup> No data.<sup>13</sup> Average, 1908-1910.

TABLE 65.—Potato crop of countries named, 1907–1911—Continued.

Country.	1907	1908	1909	1910	1911
<b>ASIA.</b>					
Japan.....	<i>Bushels.</i> 20,310,000	<i>Bushels.</i> 21,174,000	<i>Bushels.</i> 21,996,000	<i>Bushels.</i> 24,719,000	<i>Bushels.</i> 1 24,719,000
Russia, Asiatic <sup>2</sup> .....	17,076,000	31,759,000	31,042,000	29,295,000	32,931,000
Total.....	37,386,000	52,933,000	53,038,000	54,014,000	57,650,000
<b>AFRICA</b>					
Algeria.....	1,803,000	1,549,000	1,727,000	1,687,000	1 1,687,000
Union of South Africa:					
Cape of Good Hope.....	<sup>2</sup> 1,500,000	1,304,000	<sup>1</sup> 1,304,000	587,000	<sup>1</sup> 587,000
Natal.....	444,000	405,000	392,000	<sup>4</sup> 392,000	<sup>4</sup> 392,000
Transvaal.....	549,000	519,000	410,000	773,000	1,294,000
Total, Union of South Africa.....	2,493,000	2,228,000	2,106,000	1,752,000	2,273,000
Total.....	4,296,000	3,777,000	3,833,000	3,439,000	3,960,000
<b>AUSTRALASIA.</b>					
Australia:					
Queensland.....	591,000	492,000	431,000	506,000	489,000
New South Wales.....	4,288,000	2,086,000	3,680,000	3,739,000	2,642,000
Victoria.....	6,229,000	5,044,000	5,706,000	6,532,000	4,446,000
South Australia.....	832,000	756,000	805,000	693,000	893,000
Western Australia.....	188,000	212,000	250,000	222,000	348,000
Tasmania.....	6,807,000	5,431,000	4,540,000	2,758,000	2,321,000
Total Australia.....	18,935,000	14,021,000	24,412,000	14,450,000	11,139,000
New Zealand.....	6,342,000	5,339,000	7,288,000	6,739,000	<sup>1</sup> 6,739,000
Total Australasia.....	25,277,000	19,360,000	21,700,000	21,189,000	17,878,000
Grand total.....	5,122,078,000	5,295,043,000	5,595,567,000	5,274,724,000	4,748,711,000

<sup>1</sup> Year preceding.<sup>2</sup> Data for 1907 represent 10 governments and districts; all other years, 27 governments and districts.<sup>3</sup> Unofficial estimate.<sup>4</sup> Data for 1909.

TABLE 66.—Total production of potatoes in countries named in Table 65, 1900–1911.

Year.	Production.	Year.	Production.	Year.	Production.	Year.	Production.
	<i>Bushels.</i>		<i>Bushels.</i>		<i>Bushels.</i>		<i>Bushels.</i>
1900.....	4,382,031,000	1903.....	4,409,793,000	1906.....	4,789,112,000	1909.....	5,595,567,000
1901.....	4,669,958,000	1904.....	4,298,049,000	1907.....	5,122,078,000	1910.....	5,274,724,000
1902.....	4,674,000,000	1905.....	5,254,598,000	1908.....	5,295,043,000	1911.....	4,748,711,000

TABLE 67.—Average yield of potatoes in countries named, bushels per acre, 1900–1911.

Year.	United States.	Russia (European). <sup>1</sup>	Germany. <sup>1</sup>	Austria. <sup>1</sup>	Hungary proper. <sup>1</sup>	France. <sup>1</sup>	United Kingdom. <sup>2</sup>
Average (1900–1909).....	91.4	99.9	200.0	151.1	118.7	133.8	193.8
1902.....	96.0	107.5	199.4	152.4	113.3	114.1	183.7
1903.....	84.7	91.1	197.0	126.2	125.0	120.2	166.1
1904.....	110.4	88.4	164.2	126.1	86.2	123.4	195.6
1905.....	87.0	106.6	216.7	182.5	126.8	142.5	218.8
1906.....	102.2	94.9	193.3	158.4	128.7	99.5	192.2
1907.....	95.4	102.4	205.3	173.2	126.6	136.2	171.0
1908.....	85.7	102.9	209.2	154.0	96.6	163.7	231.1
1909.....	106.1	111.5	208.9	157.3	125.2	160.3	222.1
1910.....	93.8	<sup>2</sup> 119.8	196.1	160.0	117.4	81.9	209.1
1911.....	80.9	<sup>2</sup> 106.6	154.0	137.2	106.3	121.8	238.5
Average (1902–1911).....	94.2	102.9	194.4	152.7	115.2	124.4	202.8

<sup>1</sup> Bushels of 60 pounds.<sup>2</sup> Winchester bushels.<sup>3</sup> Includes Asiatic Russia.

STATISTICS OF POTATOES.

609

TABLE 68.—Acreage, production, and value of potatoes, by States, 1912.

State and division.	Acreage.	Production.	Farm value Dec.1.	State and division.	Acreage.	Production.	Farm value Dec.1.
	<i>Acres.</i>	<i>Bushels.</i>	<i>Dollars.</i>		<i>Acres.</i>	<i>Bushels.</i>	<i>Dollars.</i>
Maine.....	117,000	23,166,000	12,741,000	North Dakota..	52,000	6,656,000	1,864,000
N. Hampshire...	17,000	2,380,000	1,452,000	South Dakota..	62,000	6,510,000	2,344,000
Vermont.....	26,000	3,640,000	2,002,000	Nebraska.....	118,000	9,440,000	4,814,000
Massachusetts...	26,000	3,380,000	2,535,000	Kansas.....	70,000	5,740,000	4,190,000
Rhode Island....	5,000	565,000	435,000	N. C. W. of Miss. River.	816,000	88,367,000	36,703,000
Connecticut.....	23,000	2,461,000	1,920,000	Kentucky.....	51,000	5,151,000	3,451,000
New York.....	360,000	38,160,000	22,133,000	Tennessee.....	38,000	3,344,000	2,341,000
New Jersey.....	92,000	9,936,000	6,558,000	Alabama.....	15,000	1,215,000	1,094,000
Pennsylvania...	265,000	28,885,000	16,464,000	Mississippi....	10,000	890,000	801,000
N. Atlantic....	931,000	112,573,000	66,240,000	Louisiana.....	20,000	1,460,000	1,212,000
Delaware.....	11,000	1,100,000	770,000	Texas.....	52,000	3,276,000	3,440,000
Maryland.....	37,000	4,144,000	2,404,000	Oklahoma.....	29,000	1,740,000	1,618,000
Virginia.....	95,000	8,265,000	5,372,000	Arkansas.....	25,000	1,750,000	1,610,000
West Virginia...	47,000	5,264,000	3,264,000	S. Central....	240,000	18,826,000	15,567,000
North Carolina..	30,000	2,550,000	1,938,000	Montana.....	37,000	6,105,000	2,442,000
South Carolina..	10,000	900,000	1,008,000	Wyoming.....	11,000	1,540,000	924,000
Georgia.....	12,000	936,000	814,000	Colorado.....	95,000	8,075,000	3,311,000
Florida.....	11,000	1,023,000	1,125,000	New Mexico....	8,000	900,000	585,000
S. Atlantic....	253,000	24,182,000	16,695,000	Arizona.....	1,000	125,000	156,000
Ohio.....	186,000	20,832,000	11,041,000	Utah.....	19,000	3,515,000	1,722,000
Indiana.....	87,000	9,918,000	4,959,000	Nevada.....	12,000	2,136,000	1,282,000
Illinois.....	137,000	13,837,000	8,302,000	Idaho.....	35,000	6,475,000	1,878,000
Michigan.....	350,000	36,750,000	15,068,000	Washington....	68,000	11,356,000	4,088,000
Wisconsin.....	291,000	34,920,000	11,873,000	Oregon.....	65,000	10,075,000	3,123,000
N. C. E. of Miss. River.	1,051,000	116,257,000	51,243,000	California....	78,000	10,140,000	6,591,000
Minnesota.....	245,000	33,075,000	9,261,000	Far Western..	420,000	60,442,000	26,102,000
Iowa.....	174,000	18,966,000	8,724,000	United States.	3,711,000	420,647,000	212,550,000
Missouri.....	95,000	7,980,000	5,506,000				

TABLE 69.—Condition of potato crop, United States, on first of months named, 1891-1912.

Year.	July.	Aug.	Sept.	Oct.	Year.	July.	Aug.	Sept.	Oct.
	<i>P. ct.</i>	<i>P. ct.</i>	<i>P. ct.</i>	<i>P. ct.</i>		<i>P. ct.</i>	<i>P. ct.</i>	<i>P. ct.</i>	<i>P. ct.</i>
1891.....	95.3	96.5	94.8	91.3	1902.....	92.9	94.8	89.1	82.5
1892.....	90.0	86.8	74.8	67.7	1903.....	88.1	87.2	84.3	74.6
1893.....	94.8	86.0	71.8	71.2	1904.....	93.9	94.1	91.6	89.5
1894.....	92.3	74.0	62.4	64.3	1905.....	91.2	87.2	80.9	74.3
1895.....	91.5	89.7	90.8	87.4	1906.....	91.5	89.0	85.3	82.2
1896.....	99.0	94.8	83.2	81.7	1907.....	90.2	88.5	80.2	77.0
1897.....	87.8	77.9	66.7	61.6	1908.....	89.6	82.9	73.7	68.7
1898.....	95.5	83.9	77.7	72.5	1909.....	93.0	85.8	80.9	78.8
1899.....	93.8	85.0	86.3	81.7	1910.....	86.3	75.8	70.5	7.8
1900.....	91.3	88.2	80.0	74.4	1911.....	78.0	62.3	59.8	62.3
1901.....	87.4	62.3	62.2	54.0	1912.....	88.9	87.8	87.2	85.1

TABLE 70.—Acreage, production, value, exports, etc., of potatoes, United States, 1849-1912.

Year.	Acreage planted and harvested.	Average yield per acre.	Production.		Average farm price per bushel Dec. 1.	Farm value Dec. 1.	Chicago price per bushel, Burbank. <sup>1</sup>				Domestic exports, fiscal year beginning July 1.	Imports during fiscal year beginning July 1.	
							December.		May of following year.				
							Low.	High.	Low.	High.			
1849 <sup>2</sup>			<i>65,798,000</i>										
1859 <sup>2</sup>			<i>111,149,000</i>										
1866...	1,069,000	100.2	107,201,000	47.3	50,723,000								
1867...	1,192,000	82.0	97,783,000	65.9	64,462,000							198,265	209,555
1868...	1,132,000	93.8	106,090,000	59.3	62,919,000							508,249	138,470
1869...	1,222,000	109.5	133,886,000	42.9	57,481,000							596,968	75,336
1869 <sup>2</sup>			<i>143,337,000</i>										
1870...	1,325,000	86.6	114,775,000	65.0	74,621,000							553,070	458,758
1871...	1,221,000	98.7	120,462,000	53.9	64,905,000							621,537	96,259
1872...	1,331,000	85.3	113,516,000	53.5	60,692,000							515,306	346,840
1873...	1,295,000	81.9	106,089,000	65.2	69,154,000							497,413	549,073
1874...	1,310,000	80.9	105,981,000	61.5	65,223,000							609,642	188,757
1875...	1,510,000	110.5	166,877,000	34.4	57,358,000							704,379	92,148
1876...	1,742,000	71.7	124,827,000	61.9	77,320,000							529,650	3,205,555
1877...	1,792,000	94.9	170,092,000	43.7	74,272,000							744,409	528,584
1878...	1,777,000	69.9	124,127,000	58.7	72,924,000							626,342	2,624,149
1879...	1,837,000	98.9	181,626,000	43.6	79,154,000							696,080	721,868
1879 <sup>2</sup>			<i>169,459,000</i>										
1880...	1,843,000	91.0	167,660,000	48.3	81,062,000							638,840	2,170,372
1881...	2,042,000	53.5	109,145,000	91.0	99,291,000							408,286	8,789,860
1882...	2,172,000	78.7	170,973,000	55.7	95,305,000							439,443	2,362,362
1883...	2,289,000	90.9	208,164,000	42.2	87,849,000							554,613	425,408
1884...	2,221,000	85.8	190,642,000	39.6	75,524,000							380,868	658,633
1885...	2,266,000	77.2	175,029,000	44.7	78,153,000							494,948	1,937,416
1886...	2,287,000	73.5	168,051,000	46.7	78,442,000	44	47	33	50			434,864	1,432,490
1887...	2,357,000	56.9	134,103,000	68.2	91,507,000	70	83	65	85			403,880	8,259,538
1888...	2,533,000	79.9	202,365,000	40.2	81,414,000	30	37	24	45			471,955	883,380
1889...	2,648,000	77.4	204,881,000	35.4	72,611,000	33	45	30	60			406,618	3,415,578
1889 <sup>2</sup>			<i>217,546,000</i>										
1890...	2,652,000	55.9	148,290,000	75.8	112,342,000	82	93	95	110			341,189	5,401,912
1891...	2,715,000	93.7	254,424,000	35.8	91,013,000	30	40	30	50			557,022	186,871
1892...	2,548,000	61.5	156,655,000	66.1	103,568,000	60	72	70	98			845,720	4,317,021
1893...	2,605,000	70.3	183,034,000	59.4	108,662,000	51	60	64	88			803,111	3,002,578
1894...	2,738,000	62.4	170,787,000	53.6	91,527,000	43	58	40	70			572,957	1,341,533
1895...	2,955,000	100.6	297,237,000	26.6	78,985,000	18	24	10	23			680,049	175,240
1896...	2,767,000	91.1	252,235,000	28.6	72,182,000	18	26	19	26			926,646	246,178
1897...	2,535,000	64.7	164,016,000	54.7	89,643,000	50	62	60	87			605,187	1,171,373
1898...	2,558,000	75.2	192,306,000	41.4	79,575,000	30	36	33	52			579,833	530,420
1899...	2,581,000	88.6	228,783,000	39.0	89,329,000	36	46	27	39			809,472	155,861
1899 <sup>2</sup>			<i>239,939,000</i>										
1900...	2,611,000	80.8	210,927,000	43.1	90,811,000	40	48	35	60			741,483	371,911
1901...	2,864,000	65.5	187,598,000	76.7	143,979,000	75	82	58	100			528,484	7,666,162
1902...	2,966,000	96.0	284,633,000	47.1	134,111,000	42	48	42	60			843,075	358,505
1903...	2,917,000	84.7	247,128,000	61.4	151,638,000	60	66	95	116			484,042	3,166,581
1904...	3,016,000	110.4	332,830,000	45.3	150,673,000	32	38	20	25			1,163,270	181,199
1905...	2,997,000	87.0	260,741,000	61.7	160,821,000	55	66	48	73			1,000,326	1,948,160
1906...	3,013,000	102.2	308,038,000	51.1	157,547,000	40	43	55	75			1,530,461	176,917
1907...	3,128,000	95.4	298,262,000	61.8	184,184,000	46	58	50	80			1,203,894	403,952
1908...	3,257,000	85.7	278,985,000	70.6	197,039,000	60	77	70	150			763,651	8,383,966
1909...	3,525,000	106.8	376,537,000	54.9	206,545,000	20	58	16	34			999,476	353,208
1909 <sup>2</sup>			<i>389,197,000</i>										
1910 <sup>3</sup>	3,720,000	93.8	349,032,000	55.7	194,566,000	30	48	35	75			2,383,887	218,984
1911 <sup>3</sup>	3,619,000	80.9	292,737,000	79.9	233,778,000	70	100					1,237,276	13,734,695
1912...	3,711,000	113.4	420,647,000	50.5	212,550,000								

<sup>1</sup> Fair to fancy since 1910.<sup>2</sup> Census figures.<sup>3</sup> Figures adjusted to census basis.

STATISTICS OF POTATOES.

TABLE 71.—Yield per acre, price per bushel, and value per acre of potatoes, by States.

State and division.	Yield per acre.							Farm price per bushel.												Value per acre, 1912. <sup>1</sup>
	10-year averages.				1910	1911	1912	10-year averages for Dec. 1.				Dec. 1, 1910.	Dec. 1, 1911.	Quarterly, 1912.						
	1870-1879	1880-1889	1890-1899	1900-1909				1870-1879	1880-1889	1890-1899	1900-1909			Mar. 1.	June 1.	Sept. 1.	Dec. 1.			
	Bu.	Bu.	Bu.	Bu.	Bu.	Bu.	Bu.	Cts.	Cts.	Cts.	Cts.	Cts.	Cts.	Cts.	Cts.	Cts.	Cts.	Dolls.		
Me.	110	94	122	180	220	190	198	51	57	54	56	42	77	103	128	60	55	108.90		
N. H.	112	88	103	114	150	125	140	56	57	58	66	52	87	116	142	84	61	85.40		
Vt.	133	95	109	113	130	105	140	44	51	47	55	45	79	108	139	99	55	77.00		
Mass.	107	92	105	103	125	93	130	68	69	68	78	70	96	131	165	93	75	97.50		
R. I.	91	88	116	124	136	110	113	75	70	69	82	69	106	140	164	89	77	87.01		
Conn.	87	78	94	95	125	85	107	72	68	64	80	70	105	142	152	100	78	83.46		
N. Y.	92	76	79	88	102	74	106	52	50	49	59	48	90	109	125	86	58	61.48		
N. J.	80	76	79	97	105	73	108	71	62	60	72	65	105	114	129	56	66	71.28		
Pa.	88	72	77	82	88	56	109	57	54	53	64	52	93	115	134	71	57	62.13		
N. Atlantic	95.3	78.3	85.4	98.8	117.1	84.8	120.9	54.8	54.1	52.4	61.4	49.9	88.5	110.8	130.9	75.1	58.8	71.15		
Del.	84	66	58	82	103	60	100	68	58	56	64	60	96	128	150	68	70	70.00		
Md.	70	68	68	80	95	45	112	66	57	54	61	54	91	114	135	58	58	64.96		
Va.	71	63	70	79	95	45	87	57	57	54	64	58	96	122	120	75	65	56.55		
W. Va.	78	68	69	86	92	45	112	52	54	54	66	67	104	128	151	71	62	69.44		
N. C.	88	64	71	73	89	48	85	63	62	60	73	73	108	150	137	73	76	64.60		
S. C.	79	57	67	79	90	70	90	91	81	86	105	105	122	142	159	135	112	100.80		
Ga.	77	62	61	72	82	72	78	109	86	83	100	105	110	132	153	110	87	67.86		
Fla.	70	73	81	90	90	90	93	90	100	119	100	100	145	158	138	115	110	102.30		
S. Atlantic	74.9	64.8	68.8	79.6	94.2	50.1	95.6	62.8	60.6	57.5	69.7	66.0	103.9	126.7	137.6	81.5	69.0	65.99		
Ohio	82	69	65	84	82	65	112	57	54	51	59	51	84	114	138	80	53	59.36		
Ind.	70	68	62	79	84	58	114	56	52	53	60	50	87	116	138	71	50	57.00		
Ill.	76	74	66	85	75	50	101	58	52	56	64	59	90	113	141	66	60	60.60		
Mich.	84	78	76	88	105	94	105	53	44	37	44	31	71	89	107	58	41	43.05		
Wis.	86	82	83	92	95	116	120	46	44	37	45	38	62	85	99	50	34	40.80		
N. C. E. Miss. R.	79.4	74.2	71.1	86.6	92.0	85.6	110.6	53.2	48.4	44.5	51.0	41.0	71.9	94.5	112.9	59.5	44.1	48.76		
Minn.	98	94	87	88	61	115	135	40	38	34	44	64	58	84	99	36	28	37.80		
Iowa	93	80	74	82	72	74	109	42	43	44	53	60	73	110	126	65	46	50.14		
Mo.	78	72	71	81	86	27	84	51	48	50	62	68	102	125	146	67	69	57.96		
N. Dak.	85	90	94	41	120	128	105	39	36	46	91	55	78	98	49	28	35.84			
S. Dak.	85	68	83	44	72	105	105	39	42	49	85	70	93	128	62	36	37.80			
Nebr.	91	75	62	83	60	52	80	43	44	55	55	84	92	124	149	73	51	40.80		
Kans.	87	69	60	76	57	22	82	59	63	59	73	90	106	132	162	73	73	59.86		
N. C. W. Miss. R.	87.7	78.1	72.1	83.0	63.8	73.8	108.3	45.3	45.9	44.6	52.9	70.8	68.8	97.6	116.3	51.8	41.5	44.98		
Ky.	73	63	62	74	92	39	101	55	52	54	65	62	107	133	175	64	67	67.67		
Tenn.	80	62	58	70	80	41	88	54	52	56	67	65	108	135	155	80	70	61.60		
Ala.	75	64	64	73	80	78	81	100	87	84	95	94	118	145	152	114	90	72.90		
Miss.	78	65	66	82	85	83	89	98	84	80	92	94	115	144	133	108	90	80.10		
La.	70	64	66	66	55	69	73	95	85	81	88	90	100	105	115	92	83	66.59		
Tex.	91	64	67	66	51	57	63	123	90	90	97	110	126	140	128	108	105	60.12		
Okla.	.....	.....	.....	76	60	18	60	.....	.....	.....	88	100	124	149	174	100	93	55.80		
Ark.	87	70	69	70	84	55	70	82	69	65	81	85	115	137	145	90	92	64.40		
S. Central	76.4	63.8	63.5	70.8	72.4	48.9	78.4	68.6	62.6	64.2	80.4	81.7	114.1	133.0	144.5	93.2	82.7	64.86		
Mont.	104	117	150	120	150	165	.....	68	53	57	85	74	82	111	70	40	66.00			
Wyo.	92	122	145	100	42	140	.....	67	60	67	82	140	151	201	95	60	84.00			
Colo.	120	82	91	130	100	35	95	78	71	52	60	55	99	100	156	80	41	33.95		
N. Mex.	78	69	77	47	80	100	.....	75	74	94	104	100	133	152	140	65	65	65.00		
Ariz.	66	72	.....	92	95	125	.....	76	74	.....	126	140	145	140	115	125	156.25			
Utah	87	120	144	142	140	185	.....	45	42	50	59	85	91	143	61	49	90.65			
Nev.	104	91	132	155	160	178	.....	167	84	58	75	80	93	102	132	130	60	106.80		
Idaho	95	128	148	142	180	185	.....	62	50	53	65	65	81	88	60	29	53.65			
Wash.	118	127	134	131	160	167	.....	49	40	50	73	68	77	75	44	36	60.12			
Oreg.	115	98	103	109	105	130	155	65	50	46	58	70	67	78	75	50	31	48.05		
Cal.	116	89	89	125	130	135	130	95	63	55	71	85	90	103	121	61	65	84.50		
Far West- ern	113.6	94.0	102.0	129.2	116.9	115.1	143.9	88.8	60.4	49.0	59.3	71.8	78.5	88.8	103.8	61.4	43.2	62.15		
U. S.	87.9	76.5	76.4	91.4	93.8	80.9	113.4	54.1	51.2	48.1	57.4	55.7	79.9	102.2	119.7	65.0	50.5	57.28		

<sup>1</sup> Basis, Dec. 1 price.

<sup>2</sup> The Territories.



TABLE 72.—Wholesale price of potatoes per bushel, 1899-1912.

Date.	Chicago.		Milwaukee.		St. Louis.		Cincinnati.	
	Burbank, per bushel.		Per bushel.		Burbank, per bushel.		Per bushel. <sup>1</sup>	
	Low.	High.	Low.	High.	Low.	High.	Low.	High.
	<i>Cents.</i>	<i>Cents.</i>	<i>Cents.</i>	<i>Cents.</i>	<i>Cents.</i>	<i>Cents.</i>	<i>Cents.</i>	<i>Cents.</i>
1899.....	26	75	15	90	25	75	110	600
1900.....	25	50	20	80	27	54	32	57
1901.....	30	125	25	185	18	140	30	120
1902.....	30	100	.....	.....	41	105	90	300
1903.....	38	85	35	90	40	125	120	300
1904.....	31	122	20	120	36	125	120	480
1905.....	18	72	10	70	27	175	25	80
1906.....	40	87	25	87	35	125	45	105
1907.....	30	75	25	90	43	125	25	85
1908.....	50	150	53	150	62	105	60	135
1909.								
January.....	60	79	60	72	73	83	72	80
February.....	65	95	60	88	80	93	75	90
March.....	80	93	70	95	89	98	85	95
April.....	85	110	70	115	92	108	95	115
May.....	70	150	80	135	85	102	95	100
June.....	20	145	30	105	40	140	90	120
July.....	15	125	20	100	40	110	50	95
August.....	38	66	40	90	35	62	70	75
September.....	42	65	45	65	45	72	55	70
October.....	35	55	40	60	42	56	55	60
November.....	15	50	30	50	40	52	30	60
December.....	20	58	30	50	40	50	30	48
Year.....	15	150	20	135	35	140	30	120
1910.								
	Fair to fancy.							
January.....	40	54	25	55	49	62	35	50
February.....	30	48	25	50	39	50	40	50
March.....	20	46	20	45	34	47	30	45
April.....	15	31	18	35	23	35	30	35
May.....	16	34	18	35	32	38	30	40
June.....	10	28	12	35	55	100	30	35
July.....	10	72	12	75	45	72½	30	60
August.....	60	98	55	100	50	80	55	65
September.....	50	98	50	105	50	80	55	65
October.....	35	74	30	70	46	60	55	65
November.....	34	50	30	55	48	54	45	52
December.....	30	48	30	55	47	53	40	52
Year.....	10	98	12	105	23	100	30	65
1911.								
January.....	30	51	30	55	47	57	40	55
February.....	40	50	32	50	47	58	43	55
March.....	35	50	25	50	47	63	43	55
April.....	38	65	30	65	57	79	55	70
May.....	35	75	30	70	42	71	45	65
June.....	30	225	30	135	46	140	45	195
July.....	60	180	40	160	85	200	110	195
August.....	100	150	90	140	75	145	110	150
September.....	55	130	55	120	70	105	80	150
October.....	47	85	50	80	69	81	65	90
November.....	50	95	60	90	73	100	65	100
December.....	70	100	72	95	68	97	88	100
Year.....	30	225	25	160	42	200	40	195
1912.								
January.....	85	115	77	120	92	120	88	115
February.....	90	115	95	115	103	120	105	115
March.....	95	155	95	135	113	137	110	125
April.....	110	170	120	155	116	152	120	150
May.....	90	200	100	150	107	145	125	135
June.....	50	190	70	150	90	140	100	135
July.....	50	115	40	90	45	120	80	115
August.....	50	100	40	80	48	75	80	110
September.....	38	95	30	60	35	68	80	115
October.....	32	90	30	60	45	64	50	65
November.....	37	65	37	55	50	61	50	65
December.....	40	65	37	55	45	57	55	65
Year.....	32	200	30	155	35	152	50	150

<sup>1</sup> Per barrel 1899 and 1902-1904.

TABLE 73.—Farm price of potatoes per bushel on first of each month, 1911-12.

Month.	United States.		North Atlantic States.		South Atlantic States.		N. Central States east of Miss. R.		N. Central States west of Miss. R.		South Central States.		Far West-ern States.	
	1912	1911	1912	1911	1912	1911	1912	1911	1912	1911	1912	1911	1912	1911
January.....	Cts. 84.5	Cts. 54.1	Cts. 94.3	Cts. 48.3	Cts. 108.4	Cts. 66.0	Cts. 74.8	Cts. 39.0	Cts. 76.1	Cts. 69.4	Cts. 119.2	Cts. 86.5	Cts. 79.4	Cts. 74.9
February.....	94.4	55.1	106.4	48.3	116.3	72.0	87.6	39.6	86.7	69.3	127.2	88.9	79.1	78.8
March.....	102.0	55.3	110.8	45.3	126.7	73.2	94.5	40.2	97.6	70.7	133.9	91.6	88.8	85.7
April.....	117.1	55.5	127.4	45.0	135.5	71.4	111.7	40.0	111.4	73.4	144.6	89.7	102.0	88.4
May.....	127.3	62.5	136.4	53.0	146.2	72.2	117.9	46.2	126.5	79.2	155.1	90.8	115.5	102.1
June.....	119.7	63.3	130.9	52.9	137.6	70.0	112.9	43.9	116.3	81.4	144.5	86.0	103.8	117.6
July.....	103.6	96.3	107.6	74.4	118.8	94.0	104.1	74.3	102.5	102.2	113.5	124.7	88.6	139.9
August.....	86.5	136.0	93.8	113.4	91.9	132.0	88.2	140.2	75.5	183.0	93.8	156.9	79.9	137.7
September.....	65.0	113.7	75.1	105.5	81.5	123.6	59.5	113.3	51.8	126.6	93.2	146.2	61.4	107.0
October.....	51.1	88.3	53.5	85.2	76.2	114.7	43.7	73.8	42.8	97.9	91.2	136.1	53.5	88.3
November.....	45.5	76.3	48.9	78.3	75.7	105.4	38.4	60.8	35.3	74.1	85.8	119.8	46.2	77.0
December.....	50.5	79.9	58.8	88.5	69.0	103.9	44.1	71.9	41.5	68.8	82.7	114.1	43.2	78.5

HAY.

TABLE 74.—Acreage, production, value, and exports of hay, United States, 1849-1912.

Year.	Acreage.		Average yield per acre.	Production.	Average farm price per ton Dec. 1.	Farm value Dec. 1.	Chicago prices No. 1 timothy per ton, by carload lots.				Domestic exports, fiscal year beginning July 1.
							December.		May of following year.		
							Low.	High.	Low.	High.	
1849 <sup>a</sup> .....	Acres.	Tons. <sup>1</sup>	Tons. <sup>1</sup>	Dolls.	Dollars.	Dolls.	Dolls.	Dolls.	Dolls.	Tons. <sup>2</sup>	
1849 <sup>a</sup> .....	.....	.....	13,839,000	.....	.....	.....	.....	.....	.....	.....	
1866.....	17,669,000	1.23	21,779,000	10.14	220,836,000	.....	.....	.....	.....	5,028	
1867.....	20,021,000	1.31	26,277,000	10.21	268,301,000	.....	.....	.....	.....	5,645	
1868.....	21,542,000	1.21	26,142,000	10.08	263,589,000	.....	.....	.....	.....	.....	
1869.....	18,591,000	1.42	26,420,000	10.18	268,933,000	.....	.....	.....	.....	6,723	
1869 <sup>a</sup> .....	.....	.....	27,316,000	.....	.....	.....	.....	.....	.....	.....	
1870.....	19,862,000	1.23	24,525,000	12.47	305,743,000	.....	.....	.....	.....	4,581	
1871.....	19,009,000	1.17	22,239,000	14.30	317,940,000	.....	.....	.....	.....	5,266	
1872.....	20,319,000	1.17	23,813,000	12.94	308,025,000	.....	.....	.....	.....	4,557	
1873.....	21,894,000	1.15	25,085,000	12.53	314,241,000	.....	.....	.....	.....	4,889	
1874.....	21,770,000	1.15	25,134,000	11.94	300,222,000	.....	.....	.....	.....	7,183	
1875.....	23,508,000	1.19	27,874,000	10.78	300,378,000	.....	.....	.....	.....	7,528	
1876.....	25,283,000	1.22	30,867,000	8.97	276,991,000	.....	.....	9.00	10.00	7,287	
1877.....	25,368,000	1.25	31,629,000	8.37	264,880,000	9.50	10.50	9.75	10.75	9,514	
1878.....	26,931,000	1.47	39,608,000	7.20	285,016,000	8.00	8.50	9.00	11.50	8,127	
1879.....	27,485,000	1.29	35,493,000	9.32	330,804,000	14.00	14.50	14.00	15.00	13,739	
1879 <sup>a</sup> .....	30,631,000	1.15	35,151,000	.....	.....	.....	.....	.....	.....	.....	
1880.....	25,864,000	1.23	31,925,000	11.65	371,811,000	15.00	15.50	17.00	19.00	12,662	
1881.....	30,889,000	1.14	35,135,000	11.82	415,131,000	16.00	16.50	15.00	16.50	10,570	
1882.....	32,340,000	1.18	38,138,000	9.73	371,170,000	11.50	12.25	12.00	13.00	13,309	
1883.....	35,516,000	1.32	46,864,000	8.19	383,834,000	9.00	10.00	12.50	17.00	16,908	
1884.....	38,572,000	1.26	48,470,000	8.17	396,139,000	10.00	11.50	15.50	17.50	11,142	
1885.....	39,850,000	1.12	44,732,000	8.71	389,753,000	11.00	12.00	10.00	12.00	13,390	
1886.....	36,502,000	1.15	41,796,000	8.46	353,438,000	9.50	10.50	11.00	12.50	13,873	
1887.....	37,665,000	1.10	41,454,000	9.97	413,440,000	13.50	14.50	17.00	21.00	18,198	
1888.....	38,592,000	1.21	46,643,000	8.76	408,500,000	11.00	11.50	10.50	21.00	21,928	
1889.....	52,949,000	1.26	66,831,000	7.04	470,394,000	9.00	10.00	9.00	14.00	36,274	
1889 <sup>a</sup> .....	52,949,000	1.26	66,831,000	.....	.....	.....	.....	.....	.....	.....	
1890.....	50,713,000	1.19	60,198,000	7.87	473,570,000	9.00	10.50	12.50	15.50	28,066	
1891.....	51,044,000	1.19	60,818,000	8.12	494,114,000	12.50	15.00	13.50	14.00	35,201	
1892.....	50,853,000	1.18	59,824,000	8.20	490,428,000	11.00	11.50	12.00	13.50	33,084	
1893.....	49,613,000	1.33	65,766,000	8.68	570,883,000	10.00	10.50	10.00	10.50	54,446	
1894.....	48,321,000	1.14	54,874,000	8.54	468,578,000	10.00	11.00	10.00	10.25	47,117	

<sup>1</sup> 2,000 pounds.

<sup>2</sup> 2,240 pounds.

<sup>3</sup> Census figures.

TABLE 74.—*Acres, production, value, and exports of hay, United States, 1849-1912—Continued.*

Year.	Acreage.	Average yield per acre.	Production.	Average farm price per ton Dec. 1.	Farm value Dec. 1.	Chicago prices No. 1 timothy per ton, by carload lots.				Domestic exports, fiscal year beginning July 1.
						December.		May of following year.		
						Low.	High.	Low.	High.	
	<i>Acres.</i>	<i>Tons.<sup>1</sup></i>	<i>Tons.<sup>1</sup></i>	<i>Dolls.</i>	<i>Dollars.</i>	<i>Dolls.</i>	<i>Dolls.</i>	<i>Dolls.</i>	<i>Dolls.</i>	<i>Tons.<sup>2</sup></i>
1895.....	44,206,000	1.06	47,079,000	8.35	393,186,000	12.00	12.50	11.50	12.00	59,052
1896.....	43,260,000	1.37	59,282,000	6.55	388,146,000	8.00	8.50	8.50	9.00	61,658
1897.....	42,427,000	1.43	60,665,000	6.62	401,391,000	8.00	8.50	9.50	10.50	81,827
1897.....	42,781,000	1.55	66,377,000	6.00	398,061,000	8.00	8.25	9.50	10.50	64,916
1898.....	41,328,000	1.37	56,656,000	7.27	411,926,000	10.50	11.50	10.50	12.50	72,716
1899 <sup>3</sup> .....	52,351,000	1.09	57,002,000	.....	.....	.....	.....	.....	.....	.....
1900.....	39,133,000	1.28	50,111,000	8.89	445,539,000	11.50	14.00	12.50	13.50	89,364
1901.....	39,391,000	1.28	50,591,000	10.01	506,192,000	13.00	13.50	12.50	13.50	153,431
1902.....	39,825,000	1.50	59,858,000	9.06	542,036,000	12.00	12.50	13.50	15.00	50,974
1903.....	39,934,000	1.54	61,306,000	9.07	556,276,000	10.00	12.00	12.00	15.00	60,730
1904.....	39,999,000	1.52	60,696,000	8.72	529,108,000	10.50	11.50	11.00	12.00	66,557
1905.....	39,362,000	1.54	60,532,000	8.52	515,960,000	10.00	12.00	11.50	12.50	70,172
1906.....	42,476,000	1.35	57,146,000	10.37	592,540,000	15.00	18.00	15.50	20.50	58,602
1907.....	44,028,000	1.45	63,677,000	11.68	743,507,000	13.00	17.50	13.00	14.00	77,281
1908.....	46,486,000	1.52	70,798,000	8.98	635,423,000	11.50	12.00	12.00	13.00	64,641
1909.....	45,744,000	1.42	64,938,000	10.62	689,345,000	16.00	17.00	12.50	16.00	55,007
1909 <sup>3</sup> .....	.....	.....	.....	.....	.....	.....	.....	.....	.....	.....
1910.....	45,691,000	1.33	60,978,000	12.26	747,769,000	16.00	19.00	18.50	23.50	55,223
1911.....	43,017,000	1.10	47,444,000	14.64	694,570,000	20.00	22.00	24.00	28.00	59,734
1912.....	49,530,000	1.47	72,691,000	11.79	856,695,000	13.00	18.00	.....	.....	.....

<sup>1</sup> 2,000 pounds.

<sup>2</sup> 2,240 pounds.

<sup>3</sup> Census figures.

TABLE 75.—*Acres, production, and value of hay, by States, 1912.*

State and division.	Acreage.	Production.	Farm value Dec. 1.	State and division.	Acreage.	Production.	Farm value Dec. 1.
	<i>Acres.</i>	<i>Tons.</i>	<i>Dollars.</i>		<i>Acres.</i>	<i>Tons.</i>	<i>Dollars.</i>
Maine.....	1,231,000	1,428,000	19,564,000	North Dakota....	364,000	510,000	2,805,000
New Hampshire.....	501,000	626,000	9,390,000	South Dakota....	460,000	672,000	4,099,000
Vermont.....	1,010,000	1,515,000	21,210,000	Nebraska.....	1,150,000	1,552,000	13,037,000
Massachusetts.....	477,000	596,000	12,814,000	Kansas.....	1,627,000	2,440,000	18,544,000
Rhode Island.....	58,000	66,000	1,465,000	N. C. W. of Miss. R.....	11,986,000	16,810,000	142,392,000
Connecticut.....	379,000	436,000	9,810,000	Kentucky.....	815,000	1,002,000	13,727,000
New York.....	4,720,000	5,900,000	87,910,000	Tennessee.....	888,000	1,154,000	18,233,000
New Jersey.....	362,000	521,000	10,420,000	Alabama.....	209,000	261,000	3,811,000
Pennsylvania.....	3,173,000	4,537,000	70,777,000	Mississippi.....	201,000	297,000	3,712,000
N. Atlantic.....	11,911,000	15,625,000	243,360,000	Louisiana.....	142,000	234,000	2,972,000
Delaware.....	72,000	96,000	1,440,000	Texas.....	387,000	542,000	5,637,000
Maryland.....	381,000	575,000	8,280,000	Oklahoma.....	385,000	481,000	3,559,000
Virginia.....	741,000	889,000	13,513,000	Arkansas.....	286,000	352,000	4,224,000
West Virginia.....	745,000	1,028,000	15,420,000	S. Central.....	3,313,000	4,323,000	55,875,000
North Carolina.....	293,000	381,000	6,363,000	Montana.....	640,000	1,216,000	10,093,000
South Carolina.....	194,000	223,000	4,014,000	Wyoming.....	452,000	859,000	7,387,000
Georgia.....	234,000	316,000	5,372,000	Colorado.....	870,000	1,905,000	16,574,000
Florida.....	43,000	54,000	977,000	New Mexico.....	187,000	436,000	3,706,000
S. Atlantic.....	2,703,000	3,562,000	55,379,000	Arizona.....	113,000	384,000	4,608,000
Ohio.....	2,960,000	4,026,000	52,338,000	Utah.....	368,000	1,023,000	8,184,000
Indiana.....	1,885,000	2,582,000	29,435,000	Nevada.....	227,000	681,000	5,925,000
Illinois.....	2,512,000	3,266,000	41,152,000	Idaho.....	692,000	1,938,000	12,209,000
Michigan.....	2,395,000	3,185,000	40,450,000	Washington.....	776,000	1,707,000	17,241,000
Wisconsin.....	2,250,000	3,600,000	43,560,000	Oregon.....	790,000	1,738,000	14,425,000
N. C. E. of Miss. R.....	12,002,000	16,659,000	206,935,000	California.....	2,500,000	3,825,000	52,402,000
Minnesota.....	1,661,000	2,541,000	16,262,000	Far Western.....	7,615,000	15,712,000	152,754,000
Iowa.....	3,537,000	4,952,000	47,044,000	United States... 49,530,000	72,691,000	856,695,000	
Missouri.....	3,187,000	4,143,000	40,601,000				

## SILK.

*Production of raw silk in countries named, 1906-1910.*

[Estimate of the Silk Manufacturers' Association of Lyons, France.]

Country.	1906	1907	1908	1909	1910 <sup>1</sup>
Western Europe:	<i>Pounds.</i>	<i>Pounds.</i>	<i>Pounds.</i>	<i>Pounds.</i>	<i>Pounds.</i>
Italy.....	10,461,000	10,626,000	9,890,000	1,486,000	7,702,000
France.....	1,333,000	1,459,000	1,446,000	9,372,000	8,702,000
Spain.....	124,000	181,000	165,000	181,000	183,000
Austria-Hungary.....	754,000	761,000	736,000	833,000	776,000
Total.....	12,672,000	13,027,000	12,237,000	11,872,000	10,362,000
Levant and Central Asia:					
Anatolia.....	1,221,000	1,327,000	1,356,000	1,466,000	1,058,000
Syria and Cyprus.....	1,037,000	1,179,000	1,080,000	981,000	1,190,000
Other provinces of Asiatic Turkey.....		322,000	320,000	276,000	287,000
Salonica and Adrianople.....	567,000	754,000	628,000	838,000	794,000
Balkan States.....	408,000	496,000	456,000	492,000	386,000
Greece and Crete.....	165,000	168,000	143,000	132,000	126,000
Caucasus.....	1,003,000	1,085,000	794,000	1,190,000	1,146,000
Persia and Turkestan (exports).....	1,385,000	1,340,000	1,160,000	1,323,000	1,186,000
Total.....	5,786,000	6,671,000	5,937,000	6,698,000	6,173,000
Far East:					
China—					
Exports from Shanghai.....	9,396,000	9,160,000	12,430,000	11,431,000	11,448,000
Exports from Canton.....	4,325,000	4,960,000	5,243,000	5,059,000	5,814,000
Japan—					
Exports from Yokohama.....	13,210,000	14,044,000	16,689,000	18,457,000	19,698,000
British India—					
Exports from Calcutta and Bombay.....	717,000	772,000	551,000	518,000	507,000
Total.....	27,648,000	28,936,000	34,913,000	35,465,000	37,467,000
Grand total.....	46,106,000	48,634,000	53,087,000	54,035,000	54,002,000

<sup>1</sup> Preliminary.

## WOOD PULP.

*International trade in wood pulp, 1906-1910.<sup>1</sup>*

## EXPORTS.

Country.	Year beginning—	1906	1907	1908	1909	1910
		<i>Pounds.</i>	<i>Pounds.</i>	<i>Pounds.</i>	<i>Pounds.</i>	<i>Pounds.</i>
Austria-Hungary.....	Jan. 1	176,917,829	187,836,660	177,784,025	173,668,467	194,807,715
Belgium.....	Jan. 1	68,233,066	72,943,332	54,463,780	59,705,365	82,609,340
Canada.....	Jan. 1	2,397,000,000	2,483,000,000	2,480,000,000	561,487,800	667,955,900
Finland.....	Jan. 1	123,858,426	133,410,176	140,860,769	157,561,012	191,271,652
Germany <sup>2</sup> .....	Jan. 1	156,740,026	211,885,779	281,362,458	341,335,793	388,760,487
Norway.....	Jan. 1	1,114,716,540	1,227,103,672	1,310,902,325	1,326,893,206	1,401,685,165
Sweden.....	Jan. 1	914,501,238	1,170,316,873	1,242,850,222	1,242,456,239	1,682,832,631
Switzerland.....	Jan. 1	13,901,905	13,066,133	12,338,167	11,168,724	13,013,313
United States.....	Jan. 1	28,267,309	24,839,012	22,595,379	17,905,481	16,721,779
Other countries.....		79,751,207	75,160,286	56,826,000	74,190,000	470,249,000
Total.....		3,073,887,546	3,599,561,923	3,779,983,125	3,966,372,087	4,699,906,982

<sup>1</sup> See "General note," p. 526.<sup>2</sup> Estimated from value.<sup>3</sup> Not including free ports prior to Mar. 1, 1906.<sup>4</sup> Preliminary.

TABLE 76.—Yield per acre, price per ton, and value per acre of hay, by States.

State and division.	Yield per acre.							Farm price per ton.								Value per acre 1912. <sup>1</sup>
	10-year averages.							10-year averages for Dec. 1.								
	1870-1879	1880-1889	1890-1899	1900-1909	1910	1911	1912	1870-1879	1880-1889	1890-1899	1900-1909	Dec. 1, 1910.	Dec. 1, 1911.	Dec. 1, 1912.		
	T's.	T's.	T's.	T's.	T's.	T's.	T's.	Dolls	Dolls	Dolls	Dolls	Dolls	Dolls	Dolls	Dolls	
Maine.....	0.90	0.96	0.99	1.07	1.25	1.10	1.16	12.64	11.56	10.05	11.47	12.80	14.40	13.70	15.89	
New Hampshire.....	1.01	.94	1.01	1.07	1.20	1.05	1.25	16.92	11.72	11.80	14.34	15.80	17.20	15.00	18.75	
Vermont.....	1.06	1.07	1.22	1.28	1.35	1.30	1.50	10.85	10.32	9.56	11.13	12.40	14.00	14.00	21.00	
Massachusetts.....	1.13	1.10	1.20	1.27	1.28	1.08	1.25	18.81	17.02	15.43	17.11	19.10	23.00	21.50	26.88	
Rhode Island.....	1.05	.99	.97	1.12	1.18	1.00	1.13	22.02	16.72	16.18	18.15	19.60	24.10	22.20	25.09	
Connecticut.....	1.21	1.01	1.03	1.14	1.35	1.10	1.15	18.89	15.87	14.83	15.88	19.00	23.50	22.50	25.88	
New York.....	1.20	1.13	1.12	1.22	1.32	1.02	1.25	12.68	12.02	10.09	12.10	13.70	17.90	14.90	18.80	
New Jersey.....	1.24	1.13	1.19	1.32	1.50	1.05	1.44	17.72	15.11	13.32	15.43	18.20	22.00	20.00	23.62	
Pennsylvania.....	1.19	1.15	1.19	1.32	1.38	1.00	1.43	13.88	12.11	10.85	13.45	15.00	20.00	15.60	22.31	
N. Atlantic.....	1.14	1.09	1.13	1.23	1.33	1.05	1.31	13.56	12.42	10.88	13.51	14.61	18.14	15.58	20.43	
Delaware.....	1.06	1.07	1.14	1.36	1.43	.88	1.33	17.60	14.16	12.16	14.31	14.80	22.50	15.00	19.95	
Maryland.....	1.11	1.09	1.12	1.27	1.35	.72	1.51	16.52	13.44	11.85	13.56	15.40	22.40	14.40	21.74	
Virginia.....	1.18	1.11	1.09	1.27	1.19	.64	1.20	14.20	12.41	10.88	13.46	14.50	20.15	15.20	18.24	
West Virginia.....	1.14	1.03	1.16	1.36	1.20	.66	1.38	11.19	10.22	10.08	13.32	15.00	20.00	15.00	20.70	
North Carolina.....	1.28	1.16	1.41	1.54	1.50	1.05	1.30	11.06	11.66	10.55	13.44	14.60	17.00	16.70	21.71	
South Carolina.....	1.05	1.12	1.31	1.35	1.25	1.08	1.15	18.11	13.76	10.71	13.30	16.00	17.00	18.00	20.70	
Georgia.....	1.37	1.24	1.39	1.56	1.40	1.35	1.35	17.53	13.93	12.38	15.04	16.40	17.00	17.00	22.95	
Florida.....	1.07	1.38	1.38	1.33	1.30	1.25	.....	16.28	15.04	15.99	17.00	18.50	18.10	22.62	.....	
S. Atlantic.....	1.15	1.08	1.18	1.34	1.27	.76	1.32	14.01	12.18	10.81	13.55	15.02	19.28	15.55	20.49	
Ohio.....	1.17	1.22	1.22	1.38	1.39	.98	1.36	10.69	10.35	8.52	10.06	12.50	18.90	13.00	17.68	
Indiana.....	1.25	1.28	1.24	1.36	1.30	.94	1.37	9.61	9.03	7.89	9.62	11.90	16.80	11.40	15.62	
Illinois.....	1.34	1.31	1.23	1.35	1.33	.82	1.30	7.94	8.02	7.65	9.53	12.00	17.00	12.60	16.38	
Michigan.....	1.20	1.24	1.21	1.34	1.30	1.16	1.33	11.46	10.65	9.06	9.51	13.67	17.00	12.70	16.89	
Wisconsin.....	1.36	1.19	1.29	1.56	1.00	1.20	1.60	8.28	8.87	7.43	8.88	15.10	15.60	12.10	19.36	
N. C. E. Miss. R.....	1.26	1.25	1.24	1.39	1.27	1.02	1.39	9.58	9.01	8.03	9.50	12.88	17.10	12.42	17.24	
Minnesota.....	1.43	1.31	1.44	1.66	1.00	1.00	1.53	5.02	6.20	4.67	6.02	9.10	11.90	6.40	9.79	
Iowa.....	1.42	1.26	1.34	1.55	1.05	.80	1.40	5.17	5.29	5.51	6.47	9.00	12.50	9.50	13.30	
Missouri.....	1.32	1.21	1.23	1.28	1.30	.60	1.30	8.88	7.80	6.49	8.15	9.20	13.30	9.80	12.74	
North Dakota.....	1.27	1.35	1.39	.55	1.10	1.40	.....	4.05	3.69	4.70	7.60	7.00	5.50	7.70	.....	
South Dakota.....	1.28	1.18	1.39	.80	.55	1.46	.....	4.05	3.55	4.47	7.10	8.50	6.10	8.91	.....	
Nebraska.....	1.52	1.31	1.26	1.55	1.00	.85	1.35	3.74	3.67	4.05	5.09	8.90	9.70	8.40	11.34	
Kansas.....	1.46	1.26	1.23	1.41	1.15	.85	1.50	3.92	4.41	3.92	5.63	7.80	9.90	7.60	11.40	
N. C. W. Miss. R.....	1.42	1.26	1.28	1.45	1.10	.78	1.40	5.38	5.21	4.84	6.37	8.96	11.54	8.47	11.88	
Kentucky.....	1.25	1.17	1.26	1.38	1.29	.95	1.23	11.73	10.88	9.92	11.86	13.10	17.30	13.70	16.85	
Tennessee.....	1.32	1.22	1.31	1.52	1.40	1.00	1.30	13.54	11.66	10.57	12.48	13.40	16.70	15.80	20.54	
Alabama.....	1.32	1.22	1.60	1.73	1.43	1.40	1.25	15.99	13.65	10.83	12.58	13.20	12.80	14.60	18.25	
Mississippi.....	1.41	1.26	1.56	1.65	1.42	1.50	1.48	17.36	12.95	9.81	11.13	12.20	11.00	12.50	18.50	
Louisiana.....	1.34	1.24	1.74	1.89	1.75	1.30	1.65	19.50	12.07	9.75	11.54	11.50	12.00	12.70	20.96	
Texas.....	1.32	1.26	1.25	1.57	1.15	1.00	1.40	12.23	9.88	7.79	8.99	12.00	11.90	10.40	14.56	
Oklahoma.....	1.23	1.23	1.30	1.05	.80	1.25	.....	.....	.....	5.65	8.40	8.00	7.40	9.25	.....	
Arkansas.....	1.39	1.24	1.27	1.50	1.35	1.15	1.23	14.33	11.48	8.87	10.11	11.00	13.00	12.00	14.76	
S. Central.....	1.28	1.22	1.31	1.46	1.22	.98	1.30	12.81	11.13	9.45	10.49	11.48	14.22	12.93	16.87	
Montana.....	1.11	1.26	1.80	1.40	2.00	1.90	.....	10.96	8.35	8.64	12.50	10.00	8.30	15.77	.....	
Wyoming.....	1.45	1.15	1.40	2.08	2.40	2.10	1.90	21.98	10.66	7.33	7.19	12.50	10.30	8.60	16.34	
Colorado.....	1.23	1.99	2.35	2.00	2.02	1.29	.....	13.58	6.84	8.67	10.80	9.30	8.70	19.05	.....	
New Mexico.....	1.18	2.20	2.36	2.10	2.60	2.33	.....	12.52	8.84	10.78	11.50	13.00	8.50	19.80	.....	
Arizona.....	1.20	2.14	3.03	2.10	3.86	3.40	.....	12.83	9.17	12.13	13.00	12.00	12.00	40.80	.....	
Utah.....	1.36	2.24	2.90	3.00	2.50	2.78	.....	7.00	5.72	7.44	9.00	9.00	8.00	22.24	.....	
Nevada.....	1.40	1.33	2.34	2.41	3.40	3.40	.....	19.57	11.03	7.02	8.80	10.80	9.50	8.70	26.10	
Idaho.....	1.23	2.23	2.85	3.00	3.10	2.80	.....	9.36	6.23	6.94	9.00	7.60	6.30	17.64	.....	
Washington.....	1.32	1.72	2.82	2.10	2.40	2.20	.....	9.95	8.74	11.17	15.75	12.00	10.10	22.22	.....	
Oregon.....	1.51	1.31	1.72	1.12	1.10	2.10	2.20	12.51	10.68	7.54	8.86	12.10	9.60	8.30	18.26	
California.....	1.44	1.42	1.61	1.83	1.83	1.75	1.53	15.15	11.32	9.23	10.61	9.60	10.90	13.70	20.96	
Far Western.....	1.44	1.37	1.76	2.26	2.21	2.33	2.06	14.58	10.94	7.88	8.85	11.04	10.12	9.72	20.06	
United States.....	1.23	1.20	1.28	1.44	1.33	1.10	1.47	10.88	9.25	7.62	9.59	12.26	14.29	11.79	17.30	

<sup>1</sup> Basis, Dec. 1 price.

<sup>2</sup> The Territories.

TABLE 77.—Farm price of hay per ton on first of each month, 1911–12.

Month.	United States.		North Atlantic States.		South Atlantic States.		N. Central States East of Miss. R.		N. Central States West of Miss. R.		South Central States.		Far West-ern States.	
	1912	1911	1912	1911	1912	1911	1912	1911	1912	1911	1912	1911	1912	1911
	<i>Dolls.</i>	<i>Dolls.</i>	<i>Dolls.</i>	<i>Dolls.</i>	<i>Dolls.</i>	<i>Dolls.</i>	<i>Dolls.</i>	<i>Dolls.</i>	<i>Dolls.</i>	<i>Dolls.</i>	<i>Dolls.</i>	<i>Dolls.</i>	<i>Dolls.</i>	<i>Dolls.</i>
January.....	14.85	12.24	18.48	14.75	20.29	14.99	17.55	12.86	11.81	9.03	12.85	11.47	9.77	10.50
February.....	15.44	12.29	18.71	14.48	20.64	14.79	18.07	13.09	13.18	8.67	13.62	11.68	10.31	11.32
March.....	15.69	12.09	18.92	14.50	21.56	14.90	18.61	12.80	13.11	8.30	13.76	11.90	10.48	10.80
April.....	16.79	11.89	20.13	14.13	22.36	15.38	19.73	12.80	14.94	8.15	15.27	11.52	10.84	10.50
May.....	17.64	12.29	21.04	14.43	23.21	16.31	21.15	13.79	15.72	8.23	16.31	11.59	11.03	10.52
June.....	17.54	13.16	21.49	15.90	22.97	18.21	20.97	15.22	14.61	8.23	15.75	11.99	11.22	10.46
July.....	15.57	13.99	19.65	16.53	20.57	18.36	17.97	15.64	11.94	10.91	14.38	12.83	10.56	10.15
August.....	12.98	14.67	17.12	17.25	17.36	20.10	14.33	15.89	9.05	12.95	12.58	13.56	9.09	9.46
September.....	12.14	14.61	16.18	17.43	16.12	20.35	13.32	16.59	8.18	11.91	11.43	13.08	8.67	9.06
October.....	11.76	14.50	15.46	17.65	15.75	19.41	12.80	16.47	7.97	11.43	11.24	12.84	8.72	9.12
November.....	11.80	14.62	15.36	17.61	15.19	19.72	12.41	16.91	8.48	11.74	11.52	12.56	9.00	8.83
December.....	11.79	14.64	15.58	18.24	15.55	19.76	12.42	17.08	8.47	11.44	12.93	12.64	9.72	9.94

TABLE 78.—Wholesale price of hay (baled) per ton, 1899–1912.

Date.	Chicago.		Cincinnati.		St. Louis.		New York.		
	No. 1 timothy.		No. 1 timothy.		No. 1 timothy.		No. 1 timothy. <sup>1</sup>		
	Low.	High.	Low.	High.	Low.	High.	Low.	High.	
1899.....	\$7.50	\$13.00	\$7.75	\$13.00	\$8.00	\$12.00	\$0.65	\$0.95	
1900.....	10.00	14.00	11.50	15.00	9.75	14.50	.87½	.97½	
1901.....	11.50	15.00	11.50	15.50	11.50	17.50	.87½	1.00	
1902.....	10.00	17.50	11.00	16.50	9.50	16.00	17.00	22.00	
1903.....	10.00	15.00	11.00	19.50	9.50	25.00	16.00	26.00	
1904.....	9.00	15.00	11.00	15.50	10.00	13.50	15.00	19.00	
1905.....	10.00	12.50	10.00	13.50	9.00	15.50	14.00	19.00	
1906.....	9.50	18.00	11.00	19.50	11.00	20.00	15.00	23.00	
1907.....	13.00	21.50	14.00	22.75	14.00	24.00	1.00	1.25	
1908.....	10.00	14.00	11.50	16.50	10.00	18.00	14.00	21.00	
1909.									
January.....	11.00	12.00	13.25	13.75	12.00	14.00	16.00	17.50	
February.....	11.00	12.00	12.75	13.25	12.00	15.00	16.00	16.50	
March.....	11.00	12.00	12.00	13.75	12.00	15.50	16.00	16.50	
April.....	12.00	13.00	13.50	15.50	12.00	17.00	17.50	17.50	
May.....	12.00	13.00	14.50	16.00	14.50	18.50	17.00	19.00	
June.....	13.00	14.00	14.75	17.00	14.00	17.50	18.50	20.00	
July.....	12.50	13.00	13.00	16.50	15.00	17.50	19.00	20.00	
August.....	14.50	15.00	14.00	14.50	12.00	17.50	19.50	21.00	
September.....	13.00	14.00	14.00	15.50	11.50	15.50	18.00	18.50	
October.....	13.00	14.00	15.00	15.50	13.50	15.50	18.50	18.50	
November.....	13.00	15.50	14.50	16.00	14.00	17.00	18.50	19.00	
December.....	16.00	17.00	16.00	17.25	15.00	17.00	19.50	20.00	
Year.....	11.00	17.00	12.00	17.25	11.50	18.50	15.50	21.00	
1910.									
January.....	16.50	18.50	17.50	19.25	16.00	18.00	21.00	24.00	
February.....	17.00	18.00	18.00	18.75	16.00	18.00	23.00	24.00	
March.....	16.00	18.00	18.00	19.50	16.00	18.50	23.00	24.50	
April.....	15.00	17.00	18.50	19.25	16.00	18.50	22.50	23.00	
May.....	12.50	16.00	17.50	18.75	16.00	18.50	22.50	23.50	
June.....	14.50	17.00	18.50	19.50	16.00	18.50	22.50	23.50	
July.....	16.50	21.00	18.75	22.00	15.00	20.50	24.00	26.00	
August.....	18.00	21.00	17.50	22.50	16.00	19.50	23.00	28.00	
September.....	16.50	18.00	17.00	19.00	16.00	18.50	22.00	23.00	
October.....	16.00	18.50	17.50	20.50	16.00	19.00	22.00	23.00	
November.....	16.00	19.00	17.50	18.50	15.50	18.50	22.00	22.50	
December.....	16.00	19.00	18.00	19.00	16.00	19.50	22.00	22.00	
Year.....	12.50	21.00	17.00	22.50	15.00	20.50	21.00	28.00	

<sup>1</sup> Per hundred pounds, 1899 to 1901 and 1907.

TABLE 79.—Wholesale price of clover and timothy seed, 1899–1912—Continued.

Date.	Clover (bushels of 60 pounds).								Timothy.							
	Cincinnati.		Chicago.		Toledo.		Detroit.		Cincinnati.		Chicago.		Milwaukee.		St. Louis.	
	Prime.		Poor to prime.		Poor to choice.				Per bushel (of 45 pounds).		Poor to choice (per 100 pounds).		Per 100 pounds.		Poor to prime (per 100 pounds).	
	Low.	High.	Low.	High.	Low.	High.	Low.	High.	Low.	High.	Low.	High.	Low.	High.	Low.	High.
1909.																
January.....	\$4.00	\$5.40	\$4.20	\$5.61	\$5.45	\$5.70	\$5.50	\$5.60	\$1.35	1.55	\$2.50	\$4.00	\$2.75	\$3.65	\$3.00	\$3.45
February.....	5.00	5.40	4.50	5.58	5.35	5.60	5.35	5.50	1.35	1.55	2.50	3.90	2.75	3.75	3.00	3.45
March.....	5.00	5.40	4.20	5.46	5.17 <sup>1</sup> / <sub>2</sub>	5.60	5.20	5.45	1.35	1.55	2.50	3.85	2.60	3.80	2.50	3.52
April.....	5.00	5.40	4.20	5.85	5.55	6.10	5.40	6.10	1.35	1.55	2.50	3.80	2.50	3.80	2.25	3.52
May.....	5.00	5.40	4.35	5.82	5.70	5.95	5.75	5.85	1.35	1.55	2.50	4.00	2.50	3.75	1.50	3.50
June.....	5.00	5.40	4.35	6.36	6.00	6.65	6.00	6.10	1.35	1.55	2.50	3.90	2.50	3.75	2.75	3.25
July.....	5.00	5.40	4.62	6.51	6.50	6.75	.....	7.00	1.35	1.55	2.50	3.80	2.50	3.50	2.50	3.70
August.....	5.00	6.00	4.20	7.02	6.70	7.25	6.65	7.00	1.35	1.65	2.50	4.00	2.50	3.50	2.50	3.55
September.....	5.80	8.25	4.95	8.25	7.10	9.55	7.00	9.25	1.35	1.65	2.50	4.00	2.50	3.75	2.50	3.60
October.....	8.00	8.50	5.40	9.00	8.80	9.35	8.85	9.15	1.40	1.65	2.50	3.75	2.50	3.75	2.50	3.50
November.....	8.00	8.50	5.40	8.70	8.52 <sup>1</sup> / <sub>2</sub>	8.95	8.50	8.90	1.30	1.55	2.50	3.75	2.50	3.75	2.50	3.50
December.....	8.00	8.50	5.70	8.55	8.70	9.22 <sup>1</sup> / <sub>2</sub>	8.70	9.15	1.30	1.55	2.50	3.75	2.90	3.60	2.50	3.50
Year.....	4.00	8.50	4.20	9.00	5.17 <sup>1</sup> / <sub>2</sub>	9.55	5.20	9.25	1.30	1.65	2.50	4.00	2.50	3.80	1.50	3.70
1910.																
January.....	7.98	8.49	9.25	15.00	3.00	9.05	8.50	9.10	1.30	1.55	2.50	3.90	2.90	4.00	2.50	3.65
February.....	7.50	8.49	9.00	14.05	3.00	8.55	7.90	8.80	1.30	1.65	2.60	3.90	2.90	4.00	2.50	3.65
March.....	6.00	7.50	7.50	13.60	3.00	8.25	6.90	8.15	1.40	1.65	2.65	3.85	2.90	3.50	3.00	3.50
April.....	5.49	6.51	6.50	12.50	3.00	7.60	6.75	7.75	1.40	1.65	2.50	3.80	2.75	3.50	3.00	3.50
May.....	5.49	6.00	6.50	11.25	3.00	6.95	6.40	6.75	1.40	1.65	2.50	3.75	2.75	3.50	3.00	3.50
June.....	5.49	6.00	6.00	11.50	3.00	7.20	6.75	7.00	1.40	1.65	2.50	4.10	2.75	3.50	3.00	3.75
July.....	5.49	6.00	6.75	12.85	4.75	8.00	7.00	8.00	1.40	2.25	3.00	5.75	2.75	5.25	3.00	5.50
August.....	5.49	7.98	8.25	15.50	5.00	9.60	7.85	9.20	2.00	3.50	4.25	8.00	4.25	6.75	5.00	7.65
September.....	7.74	7.98	9.00	17.00	2.40	10.30	8.75	10.00	3.25	4.25	5.00	9.50	5.50	9.00	7.25	10.00
October.....	7.74	8.49	8.00	15.50	3.00	9.35	8.50	9.35	3.50	4.25	6.50	9.10	7.00	9.00	5.00	9.00
November.....	6.99	8.16	8.50	14.30	3.00	9.00	8.40	8.85	3.50	4.00	8.00	9.50	7.50	9.25	5.00	9.25
December.....	6.99	7.98	8.50	15.00	4.20	9.30	8.75	9.10	3.50	4.00	8.00	9.75	7.25	9.50	5.00	9.50
Year.....	5.49	8.49	6.56	17.00	2.40	10.30	6.40	10.00	1.30	4.25	2.50	9.75	2.75	9.50	2.50	9.50
1911.																
January.....	7.00	8.00	5.40	9.00	3.00	9.25	8.75	9.10	3.50	4.00	8.00	10.70	8.00	10.00	5.00	9.75
February.....	7.00	8.25	5.40	9.00	3.00	9.20	8.80	8.85	3.50	4.25	8.50	12.50	8.00	11.50	5.00	11.25
March.....	7.00	8.25	5.40	9.30	3.00	9.55	8.60	8.69	3.75	5.00	8.00	12.50	9.00	11.50	5.00	11.25
April.....	7.00	8.25	4.80	9.30	3.00	9.40	8.60	9.00	4.50	5.00	7.00	12.00	9.00	12.00	8.00	11.00
May.....	7.50	8.25	4.80	9.60	7.00	10.00	9.00	9.25	4.00	5.00	8.00	12.00	9.00	12.00	7.00	10.50
June.....	7.50	8.00	4.80	9.90	7.00	10.20	9.25	9.50	4.00	5.00	8.00	12.00	8.00	12.00	7.00	10.50
July.....	7.50	8.00	4.80	10.80	7.25	11.50	9.50	10.50	4.00	5.00	8.00	13.25	8.00	15.00	7.00	10.50
August.....	7.50	11.00	5.70	12.15	6.00	12.80	10.50	12.00	4.00	6.90	9.00	15.00	12.00	15.00	5.00	15.00
September.....	10.00	11.00	7.80	12.30	3.00	12.50	11.50	12.25	6.00	6.25	11.00	15.50	12.00	15.00	12.00	15.50
October.....	10.00	11.00	7.80	12.45	5.50	12.70	12.00	12.50	6.00	6.25	11.00	16.00	10.00	15.00	10.00	15.75
November.....	10.00	11.00	8.10	12.45	3.00	12.72 <sup>1</sup> / <sub>2</sub>	12.25	12.40	6.00	6.25	10.00	16.25	10.00	15.25	10.00	15.75
December.....	10.00	11.00	7.80	12.45	7.00	12.75	12.10	12.50	6.00	6.25	10.00	16.25	10.00	15.50	10.00	15.75
Year.....	7.00	11.00	4.80	12.45	3.00	12.80	8.60	12.50	3.50	6.90	7.00	16.25	8.00	15.50	5.00	15.75
1912.																
January.....	10.00	11.00	8.10	13.35	4.80	13.97 <sup>1</sup> / <sub>2</sub>	12.50	13.75	6.00	6.25	16.00	16.25	10.00	15.00	10.00	15.50
February.....	10.00	13.00	9.30	13.80	6.00	14.20	13.25	14.00	6.00	6.50	15.00	16.25	10.00	15.50	7.00	15.00
March.....	12.00	13.00	7.20	13.20	4.00	13.90	12.50	13.50	6.00	6.50	15.25	16.00	10.00	15.50	7.00	13.50
April.....	12.00	13.00	7.20	12.60	4.20	13.00	12.00	12.75	6.00	6.50	13.50	15.00	5.00	15.00	2.50	13.50
May.....	12.00	13.00	6.00	11.40	4.50	13.25	12.00	13.00	6.00	6.50	11.50	14.50	5.00	11.00	5.00	10.00
June.....	10.00	13.00	5.40	10.80	7.00	12.50	12.50	12.50	4.00	6.50	11.50	12.00	6.00	10.00	5.00	10.00
July.....	10.00	11.00	5.40	10.80	7.00	9.85	12.00	12.50	4.00	5.00	6.50	12.00	4.00	10.00	5.00	10.00
August.....	9.00	11.00	6.00	9.30	5.50	10.80	11.50	12.00	2.00	5.00	5.00	6.25	3.00	6.00	3.85	5.25
September.....	9.00	10.50	6.00	10.80	4.05	12.40	10.25	10.75	1.50	2.50	4.00	5.10	2.50	4.50	2.75	4.25
October.....	9.50	10.50	7.50	10.80	3.00	12.30	10.75	11.25	1.50	2.00	4.00	4.50	2.75	4.00	2.75	4.00
November.....	9.50	10.50	10.80	10.80	3.00	11.25	10.75	11.00	1.50	2.00	3.80	4.15	2.50	3.70	2.75	3.50
December.....	9.00	10.50	4.80	10.65	3.60	11.72 <sup>1</sup> / <sub>2</sub>	11.00	11.60	1.50	2.00	4.00	4.15	2.50	3.75	2.75	3.50
Year.....	9.00	13.00	4.80	13.35	3.00	14.20	10.25	14.00	1.50	6.50	3.80	16.25	2.50	15.50	2.75	15.50

## COTTON.

TABLE 80.—Cotton crop of countries named, 1907–1911.

[No statistics for Siam and some other less important cotton-growing countries. Bales of 500 pounds, gross weight, or 478 pounds, net.]

Country.	1907	1908	1909	1910	1911
<b>NORTH AMERICA.</b>					
United States: 1	<i>Bales.</i>	<i>Bales.</i>	<i>Bales.</i>	<i>Bales.</i>	<i>Bales.</i>
Contiguous.....	11, 107, 179	13, 241, 799	10, 004, 949	11, 608, 616	15, 692, 701
Noncontiguous—Porto Rico.....	446	399	240	342	412
Total United States (except Philip- pine Islands).....	11, 107, 625	13, 242, 198	10, 005, 189	11, 608, 958	15, 693, 113
Guatemala 2.....	147	147	147	147	147
Mexico 2.....	70, 000	140, 000	200, 000	200, 455	4 200, 455
West Indies:					
British—					
Bahamas 5.....	18	27	25	13	6 27
Barbados 5.....	1, 981	2, 061	1, 348	1, 348	6 1, 520
Grenada 5.....	607	489	677	555	6 574
Jamaica 5.....	13	43	46	28	6 37
Leeward Islands.....	1, 954	6 2, 248	1, 443	1, 892	6 3, 086
St. Lucia 5.....			13	37	6 8
St. Vincent 5.....	895	880	733	1, 092	6 1, 126
Trinidad and Tobago.....	24	28	18	24	6 13
Danish 5.....	7 505	505	557	572	4 572
French: Guadeloupe 5.....	10	26	12	12	4 12
Haiti 5.....	7, 092	4 7, 092	7, 550	7, 867	4 7, 867
Total.....	11, 190, 871	13, 395, 744	10, 217, 758	11, 823, 000	15, 908, 557
<b>SOUTH AMERICA.</b>					
Argentina.....	7 2, 000	8 2, 000	7 2, 000	7 2, 000	7 2, 000
Brazil 8.....	348, 000	231, 000	265, 000	270, 000	4 270, 000
Chile 5.....	1, 134	979	788	708	636
Colombia and Venezuela 9.....	5, 000	5, 000	5, 000	5, 000	5, 000
Ecuador 5.....	34	15	49	316	4 316
Peru.....	66, 804	58, 420	44, 584	76, 869	4 76, 869
Paraguay 9.....	200	200	200	200	200
Total.....	423, 172	297, 614	317, 621	355, 093	355, 021
<b>EUROPE.</b>					
Bulgaria.....	604	691	783	1, 137	4 1, 137
Crete 9.....	700	700	700	700	700
Greece.....	9 8, 200	9 8, 200	9 8, 200	32, 285	4 32, 285
Italy 9.....	2, 700	2, 700	2, 700	2, 700	2, 700
Malta.....	443	364	379	411	6 392
Turkey, European 10.....	11 10, 000	11 10, 000	10, 000	11 10, 000	11 10, 000
Total.....	22, 647	22, 655	22, 762	47, 233	47, 214
<b>ASIA.</b>					
British India, including native States 11.....	3, 165, 189	3, 514, 728	4, 123, 849	3, 600, 837	3, 284, 519
Ceylon 5.....	664	492	404	537	711
China 9.....	1, 200, 000	1, 200, 000	1, 200, 000	1, 200, 000	1, 200, 000
Chosen (Korea) 9.....	70, 000	70, 000	70, 000	70, 000	70, 000
Cyprus.....	4, 110	3, 860	3, 436	5, 102	6 1, 615
Dutch East Indies 5.....	19, 652	19, 932	13, 235	14, 504	6 13, 948
French India 5.....			8		
French Indo-China 5.....	15, 877	20, 968	14, 138	9, 441	4 9, 451
Japan.....	8, 195	6, 437	5, 630	4, 188	7, 379
Persia 5.....	89, 689	83, 085	128, 031	123, 277	4 123, 277
Philippine Islands 12.....	6, 098	6, 098	6, 098	6, 098	6, 098

<sup>1</sup> "Linters," a by-product obtained in the oil mills, not included. Quantity of linters produced as follows: 265,282 in 1907, 343,507 in 1908, 310,433 in 1909, 397,628 in 1910, and 556,276 bales in 1911. For Porto Rico data refer to exports to foreign countries, plus shipments to the United States.

<sup>2</sup> Official estimate for 1903.

<sup>3</sup> Unofficial estimate.

<sup>4</sup> Year preceding.

<sup>5</sup> Exports.

<sup>6</sup> Preliminary.

<sup>7</sup> Data for 1908.

<sup>8</sup> Estimate based upon census returns for acreage.

<sup>9</sup> Average production as unofficially estimated.

<sup>10</sup> Data for European and Asiatic Turkey include 29 provinces and arrondissements only.

<sup>11</sup> Data for 1909.

<sup>12</sup> Net exports and consumption.

<sup>13</sup> Census, 1902.



TABLE 80.—Cotton crop of countries named, 1907-1911—Continued.

Country.	1907	1908	1909	1910	1911
<b>ASIA—continued.</b>					
Russia, Asiatic:	<i>Bales.</i>	<i>Bales.</i>	<i>Bales.</i>	<i>Bales.</i>	<i>Bales.</i>
Central Asia <sup>1</sup> .....	386,192	494,000	372,000	641,884	<sup>2</sup> 641,884
Transcaucasia.....	62,553	52,000	46,000	48,669	<sup>2</sup> 48,669
Total, Asiatic Russia.....	448,745	546,000	418,000	690,553	690,553
Turkey, Asiatic <sup>3</sup> .....	<sup>4</sup> 131,000	<sup>4</sup> 131,000	131,000	<sup>4</sup> 131,000	<sup>4</sup> 131,000
Total.....	5,159,219	5,603,500	6,113,829	5,855,517	5,538,551
<b>AFRICA.</b>					
British Africa:					
Nyasaland Protectorate <sup>5</sup> .....	844	1,582	1,729	3,634	2,845
East Africa.....	167	526	297	341	347
Gold Coast <sup>5</sup> .....	117	108	65	24	20
Natal.....	<sup>5</sup> 40	( <sup>6</sup> )	( <sup>6</sup> )	( <sup>6</sup> )	( <sup>6</sup> )
Nigeria.....	8,556	4,800	10,529	5,185	4,682
Uganda <sup>6</sup> .....	4,024	3,401	5,429	19,442	24,589
Sierra Leone <sup>5</sup> .....	27	1			
Union of South Africa <sup>5</sup> .....		82	159	104	133
Total, British Africa.....	13,775	10,500	18,208	28,730	32,616
Egypt.....	1,486,387	1,398,125	1,045,724	1,548,713	1,514,730
French Africa: <sup>5</sup>					
Algeria.....	73	163	200	124	<sup>7</sup> 327
Dahomey.....	428	342	600	556	<sup>7</sup> 623
Madagascar.....	1	4	2		
Senegal.....	110	75	6	39	<sup>2</sup> 39
Upper Senegal and Niger.....	7	62	96	89	<sup>7</sup> 69
Somali Coast.....		3	7	24	<sup>7</sup> 277
Total, French Africa.....	619	649	911	832	1,335
German Africa: <sup>5</sup>					
East Africa.....	1,068	1,246	2,395	5,398	5,765
Kamerum.....		11	11	<sup>4</sup> 11	<sup>4</sup> 11
Togo.....	1,297	1,933	2,356	4,723	2,387
Total, German Africa.....	2,365	3,190	4,762	10,132	8,163
Italian Africa—Eritrea.....	370	890	636	<sup>4</sup> 636	<sup>4</sup> 636
Belgian Congo <sup>5</sup> .....	3	1		1	1
Portuguese Africa:					
Angola <sup>8</sup> .....	425	241	420	<sup>4</sup> 420	<sup>4</sup> 420
East Africa.....	7 6		48	<sup>4</sup> 48	<sup>4</sup> 48
Total, Portuguese Africa.....	431	241	468	468	468
Soudan (Anglo-Egyptian).....	28,558	24,170	13,222	<sup>4</sup> 13,222	<sup>4</sup> 13,222
Total.....	1,532,508	1,437,766	1,083,931	1,602,734	1,571,171
<b>OCEANIA.</b>					
British: Queensland.....	76	82	90	106	130
Fiji Islands <sup>5</sup> .....	6	7		4	<sup>2</sup> 4
French: <sup>5</sup>					
New Caledonia.....		3	16	56	<sup>2</sup> 56
French Establishments.....	109	70	332	361	351
German: Bismarck Archipelago <sup>5</sup> .....	5				
Total.....	196	162	438	527	541
Grand total.....	18,328,613	20,757,441	17,756,339	19,684,104	23,421,055

<sup>1</sup> Not including Khiva and Bokhara.<sup>2</sup> Year preceding.<sup>3</sup> Data for European and Asiatic Turkey include 29 provinces and arrondissements only.<sup>4</sup> Data for 1909.<sup>5</sup> Exports.<sup>6</sup> Included in Union of South Africa.<sup>7</sup> Preliminary.<sup>8</sup> Imports from Angola into Portugal.

TABLE 81.—Total production of cotton in countries named in Table 80, 1900–1911.

Year.	Production.	Year.	Production.	Year.	Production.	Year.	Production.
	<i>Bales.<sup>1</sup></i>		<i>Bales.<sup>1</sup></i>		<i>Bales.<sup>1</sup></i>		<i>Bales.<sup>1</sup></i>
1900.....	15,893,591	1903.....	17,278,881	1906.....	22,183,148	1909.....	17,756,339
1901.....	15,926,048	1904.....	21,005,175	1907.....	18,328,613	1910.....	19,684,104
1902.....	17,331,503	1905.....	18,342,075	1908.....	20,757,441	1911.....	23,421,055

<sup>1</sup> Bales, 500 pounds gross, or 478 pounds lint, net.

TABLE 82.—Cotton acreage (harvested), by States, 1907–1912.

State or territory.	1907	1908	1909	1910	1911	1912
	<i>Acres.</i>	<i>Acres.</i>	<i>Acres.</i>	<i>Acres.</i>	<i>Acres.</i>	<i>Acres.</i>
Virginia.....	35,000	28,000	25,000	33,000	43,000	.....
North Carolina.....	1,408,000	1,458,000	1,359,000	1,478,000	1,624,000	.....
South Carolina.....	2,426,000	2,545,000	2,492,000	2,534,000	2,800,000	.....
Georgia.....	4,774,000	4,848,000	4,674,000	4,873,000	5,504,000	.....
Florida.....	265,000	265,000	237,000	257,000	308,000	.....
Alabama.....	3,439,000	3,591,000	3,471,000	3,560,000	4,017,000	.....
Mississippi.....	3,220,000	3,395,000	3,291,000	3,317,000	3,340,000	.....
Louisiana.....	1,622,000	1,550,000	930,000	975,000	1,075,000	.....
Texas.....	9,156,000	9,316,000	9,660,000	10,060,000	10,943,000	.....
Arkansas.....	1,950,000	2,296,000	2,218,000	2,238,000	2,363,000	.....
Tennessee.....	749,000	754,000	735,000	765,000	837,000	.....
Missouri.....	71,000	87,000	79,000	100,000	129,000	.....
Oklahoma.....	2,196,000	2,311,000	1,767,000	2,204,000	3,050,000	.....
Indian Territory.....						
California.....				9,000	12,000	.....
United States.....	31,311,000	32,444,000	30,938,000	32,403,000	36,045,000	.....

TABLE 83.—Production of lint cotton (excluding linters) in 500-pound gross weight bales, by States, and total value of crop, 1907 to 1912.

[As finally reported by U. S. Bureau of the Census.]

State or territory.	1907	1908	1909	1910	1911	1912
	<i>Bales.</i>	<i>Bales.</i>	<i>Bales.</i>	<i>Bales.</i>	<i>Bales.</i>	<i>Bales.</i>
Virginia.....	9,223	12,326	10,095	14,815	29,891	.....
North Carolina.....	605,310	646,958	600,606	706,142	1,075,826	.....
South Carolina.....	1,119,220	1,170,608	1,099,955	1,163,501	1,648,712	.....
Georgia.....	1,815,834	1,931,179	1,804,014	1,767,202	2,768,627	.....
Florida.....	49,794	62,089	54,011	58,949	83,388	.....
Alabama.....	1,112,698	1,345,713	1,024,350	1,194,250	1,716,534	.....
Mississippi.....	1,468,177	1,655,945	1,083,215	1,262,680	1,203,545	.....
Louisiana.....	675,428	470,136	253,412	245,648	384,597	.....
Texas.....	2,300,179	3,814,485	2,522,811	3,049,409	4,256,427	.....
Arkansas.....	774,721	1,032,920	713,463	821,233	939,302	.....
Tennessee.....	275,235	344,485	246,630	331,47	449,737	.....
Missouri.....	36,243	61,907	45,141	59,633	96,808	.....
Oklahoma.....	862,383	690,752	544,954	923,063	1,022,092	.....
Indian Territory.....						
All other.....	2,734	2,296	2,292	10,144	17,215	.....
United States.....	11,107,179	13,241,799	10,004,949	11,608,616	15,692,701	.....
Total value of crop.....	\$613,630,000	\$588,810,000	\$688,350,000	\$820,320,000	\$732,420,000	.....

TABLE 84.—Condition of cotton crop, United States, monthly, and average yield per acre, 1891-1912.

[Prior to 1901 figures of condition relate to first of month following dates indicated.]

Year.	Yield per acre.						Year.	Condition.						Average yield per acre (lint).
	May 25.	June 25.	July 25.	August 25.	September 25.	Average yield per acre (lint).		May 25.	June 25.	July 25.	August 25.	September 25.	Average yield per acre (lint).	
1891...	P. ct. 85.7	P. ct. 88.6	P. ct. 88.9	P. ct. 82.7	P. ct. 75.7	Lbs. 179.4	1902...	P. ct. 95.1	P. ct. 84.7	P. ct. 81.9	P. ct. 64.0	P. ct. 58.3	Lbs. 188.5	
1892...	85.9	86.9	82.3	76.8	73.3	209.2	1903...	74.1	77.1	79.7	81.2	65.1	174.5	
1893...	85.6	82.7	80.4	73.4	70.7	148.8	1904...	83.0	88.0	91.6	84.1	75.8	204.9	
1894...	88.3	89.6	91.8	85.9	82.7	191.7	1905...	77.2	77.0	74.9	72.1	71.2	186.1	
1895...	81.0	82.3	77.9	70.8	65.1	155.6	1906...	84.6	83.3	82.9	77.3	71.6	202.5	
1896...	97.2	92.5	80.1	64.2	60.7	124.1	1907...	70.5	72.0	75.0	72.7	67.7	178.3	
1897...	83.5	86.0	86.9	78.3	70.1	181.9	1908...	79.7	81.2	83.0	76.1	69.7	194.9	
1898...	89.0	91.2	91.2	79.8	75.4	219.0	1909...	81.1	74.6	71.9	63.7	58.5	154.3	
1899...	85.7	87.8	84.0	68.5	62.4	184.1	1910...	82.0	80.7	75.5	72.1	65.9	170.7	
1900...	82.5	75.8	76.0	68.2	67.0	194.4	1911...	87.8	88.2	89.1	73.2	71.1	208.2	
1901...	81.5	81.1	77.2	71.4	61.4	169.0	1912...	78.9	80.4	76.5	74.8	69.6	.....	

TABLE 85.—Yield per acre, farm price, and value per acre of cotton, by States.

State.	Yield per acre.							Farm price per pound.								Value per acre, 1912 <sup>1</sup> .
	10-year averages.				1910.	1911.	1912.	10-year averages, Dec. 1.			Quarterly, 1912.					
	1870-1879.	1880-1889.	1890-1899.	1900-1909.				1880-1889.	1890-1899.	1900-1909.	Dec. 1, 1910.	Dec. 1, 1911.	Mar. 1.	June 1.	Sept. 1.	
	Lbs.	Lbs.	Lbs.	Lbs.	Lbs.	Lbs.	Lbs.	Cts.	Cts.	Cts.	Cts.	Cts.	Cts.	Cts.	Cts.	
Virginia.....	175	157	155	197	212	330	8.8	7.1	9.6	13.8	9.0	11.2	11.1	12.0	.....	
North Carolina...	167	166	187	209	227	315	9.0	7.2	9.8	14.1	8.8	9.8	10.8	11.5	12.2	
South Carolina...	159	154	170	194	216	280	9.1	7.2	9.9	14.2	8.8	9.8	11.6	11.7	12.4	
Georgia.....	152	146	156	180	173	240	9.1	7.0	9.9	14.2	8.9	9.7	11.0	11.4	12.4	
Florida.....	113	109	108	123	110	130	10.3	7.7	12.8	21.0	12.0	14.5	15.0	14.0	15.7	
Alabama.....	149	143	155	162	160	204	9.0	7.0	9.7	14.2	8.8	10.0	11.2	11.1	12.1	
Mississippi.....	176	181	188	204	182	172	9.0	6.9	9.8	14.4	9.2	10.0	11.1	11.5	12.3	
Louisiana.....	195	215	222	217	120	170	9.0	7.0	9.6	14.4	8.9	9.6	11.1	11.0	11.5	
Texas.....	211	187	188	170	145	186	8.6	6.8	9.4	14.0	8.6	9.9	10.8	11.1	11.5	
Arkansas.....	213	213	208	202	175	190	8.9	6.9	9.6	14.4	8.9	9.0	11.0	11.2	12.3	
Tennessee.....	189	167	165	192	207	257	8.8	6.9	9.6	14.1	8.8	9.7	10.8	11.1	12.4	
Missouri.....	214	170	195	279	285	360	8.8	7.1	9.1	13.0	8.8	9.2	9.2	11.3	.....	
Oklahoma.....	.....	.....	211	216	200	160	.....	6.6	9.2	13.3	8.0	8.9	10.4	11.5	11.3	
California.....	.....	.....	.....	335	390	.....	.....	.....	13.3	7.5	.....	.....	.....	12.5	.....	
United States....	176.5	169.4	178.1	184.7	170.7	207.7	.....	9.0	6.9	9.7	14.2	8.8	9.8	11.0	11.3	11.9

<sup>1</sup> Basis, Dec. 1 price.

TABLE 86.—Farm price of cotton per pound on first of each month, 1911-1912.

Month.	United States.		South Atlantic States.		N. Cen. States West of Miss. R.		South Central States.		Far Western States.	
	1912	1911	1912	1911	1912	1911	1912	1911	1912	1911
January.....	Cts. 8.4	Cts. 14.4	Cts. 8.3	Cts. 14.4	Cts. 14.0	Cts. 8.4	Cts. 14.4	Cts. 8.0	Cts. 13.5	Cts. 13.5
February.....	9.0	14.3	9.0	14.5	8.7	13.6	9.1	14.2	9.0	13.7
March.....	9.8	13.9	9.8	14.1	.....	12.3	9.7	13.8	.....	13.5
April.....	10.1	13.9	10.3	14.3	9.0	13.0	10.1	13.8	.....	.....
May.....	10.9	14.2	11.1	14.6	.....	13.0	10.8	14.1	.....	.....
June.....	11.0	14.6	11.2	15.0	9.2	14.0	10.9	14.4	.....	.....
July.....	11.2	14.4	11.5	14.8	10.3	12.7	11.1	14.2	.....	.....
August.....	12.0	13.2	12.3	13.7	11.3	11.9	11.9	13.1	.....	.....
September.....	11.3	11.8	11.5	12.0	9.2	11.5	11.2	11.7	.....	11.9
October.....	11.2	10.2	11.2	10.1	11.3	10.0	11.2	10.3	10.8	.....
November.....	10.9	8.9	10.9	8.9	9.0	9.5	10.9	8.9	.....	.....
December.....	11.9	8.8	12.4	8.4	11.3	8.8	11.7	8.7	12.5	7.5

TABLE 87.—Closing price of middling Upland cotton per pound, 1899-1912.

Date.	New York.		New Orleans.		Memphis.		Galveston.		Savannah.		Charleston.	
	Low.	High.	Low.	High.	Low.	High.	Low.	High.	Low.	High.	Low.	High.
1899.....	6½	7¼	5¾	7½	5¾	7¼	5¾	7¼	5¾	7½	5½	7¾
1900.....	7½	11	7½	11¾	7¾	11¾	7¾	11	7¾	10¾	7¾	10¾
1901.....	7	12	7½	9½	7¾	9½	7¾	9½	7¾	9½	7¾	9½
1902.....	8½	9½	7¾	9½	7¾	9½	7¾	9½	7¾	9½	7¾	9½
1903.....	8.85	14.10	8½	13¾	8½	13¾	8½	13¾	8½	13¾	8½	13¾
1904.....	6.85	17.25	6½	16¾	6½	16¾	6½	16	6½	16	6½	16
1905.....	7.00	12.60	6½	12¾	6½	12¾	6½	12	6½	12	6½	12
1906.....	9.60	12.25	9½	11¾	9½	11¾	9½	11¾	9½	11¾	9½	11¾
1907.....	10.60	13.55	10½	13¾	10½	13¾	10½	13¾	10½	13¾	10½	13¾
1908.....	9.00	12.25	8½	12½	8½	12½	8½	12½	8½	12½	8½	12½
1909.												
January.....	9.25	10.00	8¾	9¾	9	9½	9	9¾	8½	9½	8½	9¾
February.....	9.65	10.00	9½	9¾	9½	9¾	9½	9¾	9½	9¾	9	9¾
March.....	9.60	9.85	9½	9½	9½	9½	9½	9½	9½	9½	9	9½
April.....	9.95	10.90	9½	10¾	9½	10¾	9½	10¾	9½	10¾	9½	10¾
May.....	10.85	11.80	10½	11	10½	11	10½	11	10½	11	10	10¾
June.....	11.20	12.00	10½	11½	10½	11½	10½	11½	10½	11½	.....	.....
July.....	12.10	13.15	11½	12¾	11½	12¾	11½	12¾	11½	12¾	.....	.....
August.....	12.40	13.10	12½	12½	12½	12½	12½	12½	12½	12½	.....	.....
September.....	12.40	13.75	12½	13¾	12½	13¾	12½	13¾	12½	13¾	11½	13
October.....	13.30	15.05	13	14¾	13	14¾	13	14¾	13	14¾	12½	14¾
November.....	14.20	15.20	14½	14¾	14½	14¾	14½	14¾	14½	14¾	14	14¾
December.....	14.65	16.15	14½	15¾	14½	15¾	14½	15¾	14½	15¾	14½	15¾
Year.....	9.25	16.15	8½	15¾	9	15¾	9	15¾	8½	15¾	8½	15¾
1910.												
January.....	13.85	16.10	14¾	15¾	15½	15¾	14¾	15¾	14¾	15¾	15½	15¾
February.....	14.10	15.25	14¾	15½	15	15¾	14¾	15	14¾	15½	14¾	15
March.....	14.65	15.35	14¾	14¾	15	15	14¾	14¾	14¾	14¾	14	14¾
April.....	14.55	15.30	14¾	14¾	14¾	14¾	14¾	14¾	14¾	14¾	14	14¾
May.....	14.50	16.05	14¾	15¾	14¾	15¾	14¾	15¾	14¾	15¾	14¾	15
June.....	14.50	15.40	14¾	15	14¾	15	14¾	15	14¾	15	.....	.....
July.....	15.25	16.45	14¾	15¾	14¾	15¾	14¾	15¾	14¾	15¾	.....	.....
August.....	15.20	19.75	14¾	15½	15	15½	14¾	15½	14¾	15½	.....	.....
September.....	15.60	15.50	13½	14½	13½	14½	13	14½	13	14½	13	14
October.....	13.75	14.90	13¾	14	13¾	14	13	14	13¾	14	13	14
November.....	14.55	15.15	14¾	14¾	14¾	14¾	14¾	14¾	14¾	14¾	14	14¾
December.....	14.80	15.25	14¾	14¾	15	15	14¾	15	14¾	14¾	14¾	14¾
Year.....	13.60	19.75	13½	15¾	13½	15¾	13¾	15¾	13¾	15¾	13	15¾
1911.												
January.....	14.75	15.00	14¾	15	15½	15½	14¾	15	14¾	14¾	14½	14¾
February.....	14.00	14.95	14¾	14¾	14¾	14¾	14¾	14¾	14¾	14¾	14½	14¾
March.....	14.20	14.65	14¾	14¾	14¾	14¾	14¾	14¾	14¾	14¾	.....	.....
April.....	14.40	15.45	14¾	15½	14¾	15½	14¾	15½	14¾	15½	.....	.....
May.....	15.35	16.15	15½	15½	15½	15½	15½	15½	15½	15½	15½	15½
June.....	14.75	15.95	15	15½	15	15½	15	15½	15	15½	15	15½
July.....	12.50	14.85	12¾	15¾	13	15	12¾	15	13	15	.....	.....
August.....	11.60	13.15	11½	12½	12	13	11½	12½	11½	13	.....	.....
September.....	10.35	12.00	10¾	11½	10¾	12	10¾	12	10¾	12	9¾	11½
October.....	9.35	10.20	9¾	10¾	9¾	10¾	9¾	10¾	9¾	10¾	8¾	9¾
November.....	9.30	9.60	9½	9¾	9½	9¾	9½	9¾	9½	9¾	8¾	9¾
December.....	9.20	9.65	9½	9¾	9½	9¾	9½	9¾	9½	9¾	8¾	9¾
Year.....	9.20	16.15	9½	15½	9½	15½	9½	15½	8¾	15½	8¾	15½
1912.												
January.....	9.35	9.70	9¾	9¾	9¾	9¾	9¾	9¾	9¾	9¾	8¾	9¾
February.....	9.90	10.70	9¾	10¾	10	10¾	10	10¾	11	10¾	10	10¾
March.....	10.35	10.90	10¾	10¾	10½	11	10	10¾	10	10¾	10	10¾
April.....	10.85	12.00	11	12	11	11½	11	11½	12	10	11	10¾
May.....	11.30	11.90	11	11½	11	11½	12	11½	12	11½	11	11½
June.....	11.40	11.90	11	12½	12	12½	11½	12½	12	11½	11	11½
July.....	11.65	13.40	12	13½	12	13½	12	13½	12	12½	11½	11½
August.....	11.25	13.10	11¾	13	11¾	13	11¾	13	11¾	13	11	11½
September.....	11.50	11.90	11½	11½	11½	11½	11½	11½	11	11	11	11
October.....	10.75	11.70	10¾	11¾	11	11½	10	11	10¾	11	11	11
November.....	11.75	13.10	11¾	12½	11½	12½	11	12½	11	12	12	12
December.....	12.75	13.20	12¾	13	13	13	13	13	12¾	12¾	12¾	12¾
Year.....	9.35	13.40	9¾	13½	9¾	13½	9¾	13½	8¾	13½	8¾	13½

TABLE 88.—*International trade in cotton, calendar years 1907–1911.*

[Bales of 500 pounds, gross weight, or 478 pounds of lint net.]

The figures for cotton refer to ginned and unginned cotton and linters, but not to mill waste, cotton batting, *scarto* (Egypt and Sudan). Wherever unginned cotton has been separately stated in the original reports it has been reduced to ginned cotton in this statement at the ratio of 3 pounds unginned to 1 pound ginned. See "General note," p. 564.]

## EXPORTS.

Country.	1907	1908	1909	1910	1911
	<i>Bales.</i>	<i>Bales.</i>	<i>Bales.</i>	<i>Bales.</i>	<i>Bales.</i>
Belgium <sup>1</sup> .....					255, 114
Brazil.....	129, 307	16, 441	45, 974	<sup>2</sup> 51, 472	<sup>2</sup> 67, 554
British India.....	2, 214, 504	1, 423, 672	1, 795, 846	2, 380, 564	1, 738, 922
China.....	275, 608	171, 132	176, 761	347, 923	244, 838
Egypt.....	1, 421, 802	1, 315, 951	1, 426, 102	1, 242, 630	1, 372, 654
France.....	193, 356	213, 789	270, 387	411, 104	<sup>2</sup> 320, 974
Germany.....	269, 545	248, 766	255, 294	231, 039	186, 465
Netherlands.....	111, 004	108, 261	134, 994	140, 922	136, 976
Persia <sup>3</sup> .....	89, 689	83, 985	128, 031	<sup>4</sup> 128, 031	<sup>4</sup> 128, 031
Peru.....	56, 909	73, 884	98, 262	65, 059	<sup>5</sup> 65, 059
United States.....	8, 384, 108	8, 749, 379	7, 790, 900	7, 289, 806	8, 919, 524
Other countries.....	161, 000	118, 000	128, 000	138, 000	<sup>2</sup> 145, 000
Total.....	13, 306, 832	12, 523, 260	12, 250, 551	12, 426, 550	13, 581, 111

## IMPORTS.

Austria-Hungary.....	928, 088	816, 436	866, 981	783, 531	907, 223
Belgium.....	287, 092	226, 181	308, 583	290, 104	582, 567
Canada.....	131, 737	125, 546	58, 181	139, 113	156, 911
France.....	1, 258, 149	1, 294, 281	1, 469, 837	1, 119, 801	<sup>2</sup> 1, 409, 108
Germany.....	2, 323, 661	2, 189, 187	2, 235, 384	1, 967, 955	2, 179, 585
Italy.....	1, 005, 283	953, 528	880, 187	805, 315	875, 714
Japan.....	1, 139, 993	890, 132	1, 071, 801	1, 350, 246	1, 124, 703
Mexico.....	3, 820	7, 610	59, 071	10, 750	<sup>6</sup> 10, 750
Netherlands.....	245, 313	243, 181	238, 003	233, 835	270, 358
Russia.....	821, 027	1, 100, 041	847, 799	910, 829	935, 248
Spain.....	422, 327	437, 748	325, 486	334, 877	417, 014
Sweden.....	95, 207	79, 754	79, 746	95, 378	92, 297
Switzerland.....	118, 429	107, 308	109, 590	96, 574	112, 749
United Kingdom.....	4, 302, 404	3, 702, 357	4, 017, 004	3, 591, 298	4, 008, 175
United States.....	236, 293	154, 662	193, 940	178, 469	211, 716
Other countries.....	299, 000	309, 000	297, 000	292, 000	<sup>2</sup> 296, 000
Total.....	13, 617, 823	12, 654, 952	13, 058, 593	12, 200, 015	13, 650, 118

<sup>1</sup> Included with "In transit" trade prior to 1911.<sup>4</sup> Data for 1909.<sup>2</sup> Preliminary.<sup>5</sup> Year preceding.<sup>3</sup> Year beginning Mar. 21.TABLE 89.—*International trade in cottonseed oil, calendar years 1907–1911.*

[See "General note," p. 564.]

## EXPORTS.

Country.	1907	1908	1909	1910	1911
	<i>Gallons.</i>	<i>Gallons.</i>	<i>Gallons.</i>	<i>Gallons.</i>	<i>Gallons.</i>
Belgium.....	1, 408, 235	1, 282, 269	1, 096, 092	935, 857	1, 041, 514
Egypt.....	220, 456	237, 737	396, 982	515, 466	488, 139
France.....	557, 587	699, 564	775, 167	277, 780	<sup>1</sup> 186, 215
Netherlands.....	76, 677	274, 829	44, 409	103, 205	43, 367
United Kingdom.....	8, 626, 987	8, 824, 704	6, 506, 155	8, 933, 717	6, 781, 525
United States.....	39, 115, 276	48, 930, 381	45, 514, 435	23, 558, 528	43, 003, 606
Other countries.....	4, 000	44, 000	49, 000	69, 000	<sup>1</sup> 51, 000
Total.....	50, 009, 218	60, 293, 484	54, 382, 240	34, 393, 553	51, 595, 366

<sup>1</sup> Preliminary.

TABLE 89.—*International trade in cottonseed oil, calendar years 1907-1911—Continued.*

IMPORTS.

Country.	1907	1908	1909	1910	1911
	<i>Gallons.</i>	<i>Gallons.</i>	<i>Gallons.</i>	<i>Gallons.</i>	<i>Gallons.</i>
Algeria.....	1,135,751	986,835	<sup>1</sup> 1,326,677	<sup>1</sup> 1,281,128	<sup>2</sup> 1,281,128
Australia.....	70,339	133,737	118,632	113,446	118,973
Austria-Hungary.....	9,641	219,461	30,306	6,437	15,285
Belgium.....	2,751,696	2,200,608	2,207,083	1,831,133	2,336,776
Brazil.....	1,220,825	916,150	669,888	<sup>3</sup> 669,888	<sup>3</sup> 669,888
Canada.....	1,665,600	1,558,995	2,113,687	3,128,362	1,829,949
Egypt.....	53,052	760,738	489,737	145,618	185,820
France.....	9,210,731	12,642,293	6,479,378	1,054,828	<sup>1</sup> 2,728,942
Germany.....	15,511,771	12,954,053	10,093,188	5,418,848	6,391,018
Italy.....	926,755	3,178,063	9,002,322	1,052,358	3,598,760
Malta <sup>4</sup> .....	192,520	221,212	291,316	234,289	<sup>2</sup> 234,289
Martinique.....	296,763	328,163	323,531	324,217	<sup>2</sup> 324,217
Mexico.....	3,343,021	4,488,606	5,489,939	3,692,532	<sup>2</sup> 3,692,532
Netherlands.....	6,109,576	6,143,543	4,432,512	3,971,079	3,543,667
Norway.....	1,235,790	1,537,473	1,491,638	1,442,761	1,491,788
Roumania.....	184,091	523,958	982,298	301,594	<sup>2</sup> 301,594
Senegal.....	380,497	365,451	411,509	402,247	<sup>2</sup> 402,247
Serbia.....	122,925	153,372	286,674	207,220	396,413
Sweden.....	748,449	840,764	625,735	607,398	680,306
United Kingdom.....	4,027,221	4,706,389	4,893,653	4,665,472	7,360,939
Uruguay <sup>5</sup> .....	426,914	383,332	<sup>6</sup> 383,332	<sup>6</sup> 383,332	<sup>6</sup> 383,332
Other countries.....	1,372,000	3,016,000	2,248,000	2,252,000	<sup>1</sup> 3,530,000
Total.....	50,995,928	58,319,196	54,391,035	32,033,187	40,344,863

<sup>1</sup> Preliminary.  
<sup>2</sup> Year preceding.  
<sup>3</sup> Data for 1909.

<sup>4</sup> Year beginning Apr. 1.  
<sup>5</sup> Year beginning July 1.  
<sup>6</sup> Data for 1908.

TOBACCO.

TABLE 90.—*Tobacco crop of countries named, 1907-1911.*

Country.	1907	1908	1909	1910	1911
NORTH AMERICA.					
United States:	<i>Pounds.</i>	<i>Pounds.</i>	<i>Pounds.</i>	<i>Pounds.</i>	<i>Pounds.</i>
Contiguous.....	698,126,000	718,061,000	1,055,765,000	1,103,415,000	905,109,000
Noncontiguous—Porto Rico.....	13,000,000	10,000,000	10,000,000	10,000,000	10,000,000
Total United States (except Philippine Islands).....	711,126,000	728,061,000	1,065,765,000	1,113,415,000	915,109,000
Canada:					
Ontario.....	( <sup>2</sup> )	<sup>1</sup> 3,504,000	5,610,000	8,750,000	<sup>3</sup> 8,750,000
Quebec.....	<sup>1</sup> 3,000,000	<sup>1</sup> 7,656,000	<sup>4</sup> 7,656,000	<sup>4</sup> 7,656,000	<sup>4</sup> 7,656,000
Other <sup>5</sup> .....	107,000	107,000	107,000	107,000	107,000
Total Canada.....	3,107,000	11,267,000	13,373,000	16,513,000	16,513,000
Cuba <sup>1</sup> .....	55,603,000	66,650,000	59,323,000	46,081,000	66,930,000
Guatemala <sup>6</sup> .....	1,300,000	1,300,000	1,300,000	1,300,000	1,300,000
Jamaica.....	300,000	<sup>7</sup> 300,000	<sup>7</sup> 300,000	<sup>7</sup> 300,000	495,000
Mexico <sup>8</sup> .....	34,711,000	34,711,000	34,711,000	34,711,000	34,711,000
Santo Domingo.....	26,400,000	<sup>1</sup> 32,500,000	30,000,000	42,000,000	<sup>3</sup> 42,000,000
Total.....	832,547,000	874,789,000	1,204,772,000	1,254,320,000	1,077,058,000
SOUTH AMERICA.					
Argentina.....	<sup>6</sup> 31,000,000	<sup>6</sup> 31,200,000	<sup>6</sup> 31,000,000	15,178,000	<sup>3</sup> 15,178,000
Bolivia <sup>6</sup> .....	3,000,000	3,000,000	3,000,000	3,000,000	3,000,000
Brazil <sup>10</sup> .....	65,460,000	32,130,000	64,654,000	75,284,000	40,761,000
Chile.....	<sup>6</sup> 6,000,000	9,067,000	2,984,000	150,000	<sup>3</sup> 150,000
Ecuador <sup>10</sup> .....	144,000	143,000	376,000	165,000	<sup>3</sup> 165,000
Paraguay <sup>6</sup> .....	13,000,000	13,000,000	13,000,000	13,000,000	13,000,000
Peru <sup>6</sup> .....	1,500,000	1,500,000	1,500,000	1,500,000	1,500,000
Total.....	120,104,000	90,040,000	116,514,000	108,277,000	73,754,000

<sup>1</sup> Unofficial estimate.  
<sup>2</sup> Small crop; no data.  
<sup>3</sup> Year preceding.  
<sup>4</sup> Data for 1908.  
<sup>5</sup> Estimated from census for 1900.

<sup>6</sup> Average production as unofficially estimated.  
<sup>7</sup> Data for 1907.  
<sup>8</sup> Data for 1906.  
<sup>9</sup> Estimated from official returns for acreage.  
<sup>10</sup> Exports.

TABLE 90.—Tobacco crop of countries named, 1907–1911—Continued.

Country.	1907	1908	1909	1910	1911
EUROPE.					
Austria-Hungary:	<i>Pounds.</i>	<i>Pounds.</i>	<i>Pounds.</i>	<i>Pounds.</i>	<i>Pounds.</i>
Austria.....	15,129,000	14,630,000	19,188,000	13,590,000	11,883,000
Hungary.....	135,013,000	165,638,000	159,622,000	160,025,000	<sup>1</sup> 160,025,000
Bosnia-Herzegovina.....	6,396,000	<sup>1</sup> 6,396,000	11,464,000	<sup>2</sup> 11,464,000	<sup>2</sup> 11,464,000
Total Austria-Hungary....	156,538,000	186,664,000	190,274,000	185,079,000	183,372,000
Belgium.....	19,476,000	18,597,000	19,474,000	23,723,000	22,046,000
Bulgaria.....	9,016,000	7,607,000	7,819,000	13,944,000	23,473,000
Denmark.....	160,000	<sup>2</sup> 160,000	<sup>2</sup> 160,000	<sup>2</sup> 160,000	258,000
France.....	40,810,000	50,056,000	42,273,000	36,446,000	40,433,000
Germany.....	63,579,000	75,858,000	62,120,000	63,612,000	64,385,000
Greece <sup>4</sup> .....	14,300,000	16,500,000	15,840,000	16,534,000	<sup>1</sup> 16,534,000
Italy.....	17,246,000	19,364,000	24,100,000	24,783,000	<sup>1</sup> 24,783,000
Netherlands <sup>5</sup> .....	1,700,000	1,700,000	1,700,000	1,700,000	1,700,000
Roumania.....	15,554,000	16,099,000	12,098,000	15,434,000	20,509,000
Russia, European.....	207,749,000	188,074,000	179,414,000	160,130,000	<sup>1</sup> 160,130,000
Servia.....	2,404,000	1,719,000	4,633,000	4,314,000	3,698,000
Sweden.....	2,300,000	2,270,000	1,962,000	1,712,000	<sup>1</sup> 1,712,000
Switzerland.....	1,601,000	2,038,000	1,725,000	<sup>1</sup> 1,725,000	1,232,000
Turkey (European) <sup>6</sup> .....	49,177,000	<sup>3</sup> 49,177,000	<sup>3</sup> 49,177,000	<sup>3</sup> 49,177,000	<sup>3</sup> 49,177,000
Total.....	601,610,000	635,883,000	612,769,000	598,473,000	613,442,000
ASIA.					
British India <sup>4</sup> .....	450,000,000	450,000,000	450,000,000	450,000,000	450,000,000
British North Borneo <sup>7</sup> .....	2,953,000	3,155,000	2,678,000	2,663,000	<sup>1</sup> 2,663,000
China: Hu-nan and Kiang-si.....	<sup>8</sup> 18,016,000	<sup>8</sup> 18,016,000	<sup>8</sup> 18,016,000	18,016,000	<sup>8</sup> 18,016,000
Dutch East Indies:					
Java <sup>9</sup> .....	125,000,000	81,000,000	84,000,000	116,000,000	<sup>1</sup> 116,000,000
Sumatra, East Coast of.....	51,460,000	51,460,000	50,100,000	44,669,000	<sup>1</sup> 51,395,000
Total Dutch East Indies....	176,460,000	132,460,000	134,100,000	160,669,000	167,395,000
Formosa.....	471,000	927,000	832,000	1,726,000	<sup>1</sup> 1,726,000
Japan.....	100,390,000	91,374,000	91,850,000	93,787,000	<sup>1</sup> 93,787,000
Philippine Islands.....	<sup>10</sup> 40,056,000	<sup>10</sup> 38,725,000	40,258,000	56,257,000	<sup>1</sup> 56,257,000
Russia, Asiatic.....	18,541,000	19,989,000	28,037,000	34,872,000	<sup>1</sup> 34,872,000
Total.....	806,887,000	754,646,000	765,771,000	817,990,000	824,716,000
AFRICA.					
Algeria.....	14,177,000	13,929,000	28,629,000	21,269,000	19,427,000
Mauritius.....	16,000	26,000	39,000	27,000	<sup>1</sup> 27,000
Nyasaland.....	585,000	570,000	1,234,000	1,742,000	2,147,000
Rhodesia.....	<sup>11</sup> 147,000	<sup>11</sup> 147,000	<sup>11</sup> 147,000	<sup>11</sup> 147,000	606,000
Tunis.....	53,000	55,000	205,000	289,000	<sup>1</sup> 289,000
Union of South Africa:					
Cape of Good Hope <sup>4</sup> .....	5,000,000	5,000,000	5,000,000	5,000,000	5,000,000
Natal.....	2,771,000	3,105,000	91,850,000	<sup>2</sup> 2,527,000	<sup>2</sup> 2,527,000
Orange River Colony.....	<sup>12</sup> 650,000	<sup>12</sup> 650,000	654,000	<sup>2</sup> 654,000	<sup>2</sup> 654,000
Transvaal.....	5,077,000	2,754,000	2,891,000	5,346,000	<sup>1</sup> 5,346,000
Total Union of South Africa	13,498,000	11,509,000	11,072,000	13,527,000	13,527,000
Total.....	28,476,000	26,236,000	41,326,000	37,001,000	36,023,000
OCEANIA.					
Australia:					
Queensland.....	723,000	274,000	604,000	450,000	849,000
New South Wales.....	602,000	385,000	430,000	728,000	953,000
Victoria.....	68,000	310,000	296,000	307,000	122,000
Total Australia.....	1,393,000	969,000	1,330,000	1,485,000	1,924,000
Fiji.....	44,000	38,000	18,000	24,000	68,000
Total.....	1,437,000	1,007,000	1,348,000	1,509,000	1,992,000
Grand total.....	2,391,061,000	2,382,601,000	2,742,500,000	2,817,570,000	2,626,985,000

<sup>1</sup> Year preceding.<sup>2</sup> Data for 1909.<sup>3</sup> Data for 1907.<sup>4</sup> Unofficial estimate.<sup>5</sup> Average production as unofficially estimated.<sup>6</sup> Not including vilayets of Scutari and Constantinople.

Exports.

<sup>7</sup> Data for 1910.<sup>8</sup> Exports. Official returns for production are less than exports.<sup>9</sup> Estimated from returns of the census.<sup>10</sup> Data for 1904.<sup>11</sup> Data for 1905.

TABLE 91.—Total production of tobacco in countries named in Table 90, 1900–1911.

Year.	Production.	Year.	Production.	Year.	Production.	Year.	Production.
	<i>Pounds.</i>		<i>Pounds.</i>		<i>Pounds.</i>		<i>Pounds.</i>
1900.....	2, 201, 193, 000	1903.....	2, 401, 268, 000	1906.....	2, 270, 298, 000	1909.....	2, 742, 500, 000
1901.....	2, 270, 213, 000	1904.....	2, 146, 641, 000	1907.....	2, 391, 061, 000	1910.....	2, 817, 570, 000
1902.....	2, 376, 054, 000	1905.....	2, 279, 728, 000	1908.....	2, 382, 601, 000	1911.....	2, 626, 985, 000

TABLE 92.—Acreage, production, value, etc., of tobacco, United States, 1849–1912.

Year.	Acreage planted and harvested (000 omitted).	Average yield per acre.	Production (000 omitted).	Average farm price per pound Dec. 1.	Farm value Dec. 1 (000 omitted).	Year.	Domestic exports of unmanufactured, fiscal year beginning July 1.	Imports of unmanufactured, fiscal year beginning July 1.	Condition of growing crops.			
									July 1.	Aug. 1.	Sept. 1.	When harvested.
	<i>Acres.</i>	<i>Lbs.</i>	<i>Lbs.</i>	<i>Cts.</i>	<i>Dolls.</i>		<i>Pounds.</i>	<i>Pounds.</i>	<i>P. ct.</i>	<i>P. ct.</i>	<i>P. ct.</i>	<i>P. ct.</i>
1849 <sup>1</sup> .....			199, 755			1900..	315, 787, 782	26, 851, 253	88.5	82.9	77.5	76.1
1859 <sup>1</sup> .....			434, 209			1901..	301, 007, 365	29, 428, 837	86.5	72.1	78.2	81.5
1869 <sup>1</sup> .....			267, 735			1902..	368, 184, 084	34, 016, 956	85.6	81.2	81.5	84.1
1879 <sup>1</sup> .....	639	739.7	472, 661			1903..	311, 971, 831	31, 162, 636	85.1	82.9	83.4	82.3
1889 <sup>1</sup> .....	695	702.5	488, 257			1904..	334, 302, 091	33, 288, 378	85.3	83.9	83.7	85.6
1899 <sup>1</sup> .....	1, 101	788.5	868, 115			1905..	312, 227, 202	41, 125, 970	87.4	84.1	85.1	85.8
1900.....	1, 046	778.0	814, 345	6.6	53, 661	1906..	340, 742, 864	40, 898, 807	86.7	87.2	86.2	84.6
1901.....	1, 039	788.0	818, 953	7.1	58, 283	1907..	330, 812, 658	35, 005, 131	81.3	82.8	82.5	84.8
1902.....	1, 031	797.3	821, 824	7.0	57, 564	1908..	287, 900, 946	43, 123, 196	86.6	85.8	84.3	84.1
1903.....	1, 038	786.3	815, 972	6.8	55, 515	1909..	357, 196, 074	46, 853, 389	89.8	83.4	80.2	81.3
1904.....	806	819.0	660, 461	8.1	53, 383	1910..	355, 327, 072	48, 203, 288	85.3	78.5	77.7	80.2
1905.....	776	815.6	633, 034	8.5	53, 519	1911..	379, 845, 320	54, 740, 380	72.6	68.0	71.1	80.5
1906.....	796	857.2	682, 429	10.0	68, 233	1912..			87.7	82.8	81.1	81.8
1907.....	821	850.5	698, 126	10.2	71, 411							
1908.....	875	820.2	718, 061	10.3	74, 130							
1909.....	1, 180	804.3	949, 357	10.1	95, 719							
1909 <sup>1</sup> .....	1, 295	815.3	1, 055, 765									
1910 <sup>2</sup> .....	1, 366	807.7	1, 103, 415	9.3	102, 142							
1911 <sup>2</sup> .....	1, 013	893.7	905, 109	9.4	85, 210							
1912.....	1, 226	785.5	962, 855	10.8	104, 063							

<sup>1</sup> Census figures.

<sup>2</sup> Figures adjusted to census basis.

TABLE 93.—Acreage, production, and value of tobacco, by States, 1912.

State and division.	Acreage.	Production.	Farm value Dec. 1.	State and division.	Acreage.	Production.	Farm value Dec. 1.
	<i>Acres.</i>	<i>Pounds.</i>	<i>Dollars.</i>		<i>Acres.</i>	<i>Pounds.</i>	<i>Dollars.</i>
New Hampshire.....	100	170, 000	31, 000	Illinois.....	900	684, 000	62, 000
Vermont.....	100	170, 000	31, 000	Wisconsin.....	42, 200	54, 438, 000	5, 988, 000
Massachusetts.....	5, 800	9, 860, 000	2, 357, 000	N. C. E. Miss. R.	148, 000	149, 386, 000	14, 613, 000
Connecticut.....	17, 500	29, 750, 000	7, 170, 000	Missouri.....	6, 000	6, 000, 000	720, 000
New York.....	4, 000	5, 200, 000	655, 000	N. C. W. Miss. R.	6, 000	6, 000, 000	720, 000
Pennsylvania.....	44, 200	64, 090, 000	5, 448, 000	Kentucky.....	441, 000	343, 980, 000	29, 926, 000
N. Atlantic..	71, 700	109, 240, 000	15, 692, 000	Tennessee.....	110, 000	72, 600, 000	5, 155, 000
Maryland.....	26, 000	17, 160, 000	1, 373, 000	Alabama.....	300	225, 000	79, 000
Virginia.....	187, 000	112, 200, 000	13, 464, 000	Louisiana.....	500	150, 000	45, 000
West Virginia.....	15, 800	12, 008, 000	1, 321, 000	Texas.....	200	140, 000	24, 000
North Carolina.....	179, 000	110, 980, 000	17, 757, 000	Arkansas.....	800	520, 000	94, 000
South Carolina.....	35, 000	24, 500, 000	2, 670, 000	S. Central.....	552, 800	417, 615, 000	35, 323, 000
Georgia.....	1, 400	1, 162, 000	349, 000	United States.	1, 225, 800	962, 855, 000	104, 063, 000
Florida.....	3, 100	2, 604, 000	781, 000				
S. Atlantic...	447, 300	280, 614, 000	37, 715, 000				
Ohio.....	86, 200	79, 304, 000	7, 217, 000				
Indiana.....	18, 700	14, 960, 000	1, 346, 000				



TABLE 94.—Yield per acre, price per pound, and value per acre of tobacco, by States.

State.	Yield per acre.							Farm price per pound.							Value per acre, 1912. <sup>1</sup>
	10-year averages.				1910	1911	1912	10-year averages for Dec. 1—				Dec. 1, 1910.	Dec. 1, 1911.	Dec. 1, 1912.	
	1870-1879	1880-1889	1890-1899	1900-1909				1870-1879	1880-1889	1890-1899	1900-1909				
	Lbs.	Lbs.	Lbs.	Lbs.	Lbs.	Lbs.	Lbs.	Lbs.	Cts.	Cts.	Cts.	Cts.	Cts.	Cts.	
New Hampshire	1,294	1,517	1,650	1,665	1,720	1,700	1,700	16.9	12.2	15.5	14.9	15.0	16.0	18.5	314.50
Vermont	1,214	1,490	1,712	1,719	1,600	1,700	1,700	18.3	14.0	15.5	13.7	14.5	16.0	18.5	314.50
Massachusetts	1,505	1,495	1,658	1,666	1,730	1,650	1,700	17.1	13.5	16.3	14.8	15.0	20.0	23.9	406.30
Connecticut	1,446	1,441	1,477	1,657	1,730	1,625	1,700	18.9	13.6	16.8	16.4	16.5	20.5	24.1	409.70
New York	939	1,326	1,110	1,174	1,250	1,330	1,300	11.0	11.9	11.4	8.9	8.5	10.4	12.6	163.80
Pennsylvania	1,275	1,213	1,134	1,331	1,500	1,420	1,450	11.8	11.7	10.9	8.6	9.3	9.5	8.5	123.25
Maryland	675	635	655	634	690	735	660	7.2	6.5	6.3	6.5	7.7	7.5	8.0	72.00
Virginia	671	582	642	717	780	800	600	7.7	7.4	6.6	7.8	9.0	9.6	12.0	52.80
West Virginia	678	612	659	708	640	750	760	9.2	9.2	9.9	9.2	10.3	8.0	11.0	83.60
North Carolina	555	477	568	622	600	710	620	9.3	10.7	8.9	8.8	10.6	11.6	16.0	99.20
South Carolina	524	248	732	766	630	810	700	10.7	13.5	10.6	8.2	8.6	12.6	10.9	76.30
Georgia	546	248	452	668	680	900	830	17.3	14.0	12.8	24.4	20.0	28.0	30.0	249.00
Florida	678	184	495	722	680	940	840	20.8	19.0	29.0	31.4	23.0	28.0	30.0	252.60
Ohio	854	899	768	875	810	925	920	6.9	7.2	6.5	8.6	8.5	7.6	9.1	83.72
Indiana	715	699	679	819	880	910	800	5.7	6.6	6.6	7.8	9.5	7.8	9.0	72.00
Illinois	746	647	620	694	790	750	760	7.0	7.4	8.1	7.5	9.5	7.8	9.0	68.40
Wisconsin	946	957	1,078	1,278	1,050	1,250	1,290	8.6	10.7	7.4	8.6	7.5	10.0	11.0	141.90
Missouri	807	804	748	733	1,050	800	1,000	7.1	7.8	8.3	11.0	12.0	12.0	12.0	120.00
Kentucky	707	741	732	833	810	880	780	6.9	7.7	6.4	7.5	8.7	7.7	8.7	67.86
Tennessee	702	633	640	734	760	810	660	7.4	7.3	8.3	7.3	8.4	8.5	7.1	46.86
Alabama	581	220	418	419	500	700	750	17.9	16.5	15.5	21.8	20.0	25.0	35.0	262.50
Mississippi	552	288	600	470	.....	.....	.....	18.8	15.0	15.0	21.0	.....	.....	.....	.....
Louisiana	.....	.....	461	450	550	450	300	.....	.....	25.3	26.2	25.0	31.0	30.0	90.00
Texas	744	306	445	581	600	650	700	21.6	16.0	20.2	22.0	25.0	20.0	17.5	122.50
Arkansas	764	568	603	578	650	600	650	12.9	8.8	11.0	13.0	16.0	12.0	18.0	117.00
United States.	737.8	721.7	719.6	811.6	807.7	893.7	785.5	8.0	8.4	7.6	8.5	9.3	9.4	10.8	84.89

<sup>1</sup> Basis, Dec. 1 price.

TABLE 95.—Wholesale price of tobacco per pound, by months, on given markets, 1908-1912.

Date.	Cincinnati, leaf, plug stock, common to good red.		Hopkinsville, leaf, common to fine.		Louisville, leaf (Burley, dark red), common to good.		Clarksville, leaf, common to fine.		Richmond, leaf, smokers, common to good.		Baltimore, leaf, (Maryland), medium to fine red.	
	Low.	High.	Low.	High.	Low.	High.	Low.	High.	Low.	High.	Low.	High.
1908.	Cents.	Cents.	Cents.	Cents.	Cents.	Cents.	Cents.	Cents.	Cents.	Cents.	Cents.	Cents.
January	8.00	17.00	Nominal.		9.00	13.00	10.00	14.50	9.00	13.00	7.00	12.00
February	8.00	15.00	11.00	20.00	9.00	14.00	10.00	15.00	9.00	13.00	7.00	12.00
March	8.00	15.00	9.00	14.50	10.00	14.00	11.00	18.00	9.25	13.25	7.00	12.00
April	8.00	16.00	9.50	16.00	10.50	14.00	11.50	18.00	9.25	13.25	7.00	12.00
May	9.00	16.00	11.00	20.00	10.50	14.00	11.50	18.00	9.25	13.25	7.00	12.00
June	9.00	16.00	10.00	18.00	10.50	15.50	11.50	18.00	9.25	13.25	7.00	12.00
July	12.00	19.00	10.50	18.00	11.50	17.00	11.00	16.50	9.25	13.25	7.00	13.00
August	12.00	19.00	11.00	18.00	13.00	17.00	11.00	16.50	9.25	13.25	8.00	13.00
September	12.00	19.00	9.00	13.00	13.00	16.50	10.00	16.50	9.25	13.25	8.00	13.00
October	12.00	19.00	8.00	13.00	13.00	17.00	9.00	14.50	9.25	13.25	8.50	13.00
November	12.00	19.00	8.50	12.50	14.00	18.50	9.00	14.00	5.00	13.25	6.50	13.00
December	13.50	20.00	7.50	12.50	14.50	19.00	9.00	14.00	5.00	10.00	6.50	13.00
Year.....	8.00	20.00	7.50	20.00	9.00	19.00	9.00	18.00	5.00	13.25	6.50	13.00

TABLE 95.—Wholesale price of tobacco per pound, by month, on given markets, 1908-1912—Continued.

Date.	Cincinnati, leaf, plug stock, common to good red.		Hopkinsville, leaf, common to fine.		Louisville, leaf (Burley, dark red), common to good.		Clarksville, leaf, common to fine.		Richmond, leaf, smokers, common to good.		Baltimore, leaf, (Maryland), medium to fine red.	
	Low.	High.	Low.	High.	Low.	High.	Low.	High.	Low.	High.	Low.	High.
1909.	<i>Cents.</i>	<i>Cents.</i>	<i>Cents.</i>	<i>Cents.</i>	<i>Cents.</i>	<i>Cents.</i>	<i>Cents.</i>	<i>Cents.</i>	<i>Cents.</i>	<i>Cents.</i>	<i>Cents.</i>	<i>Cents.</i>
January.....	13.50	20.00	7.50	9.50	14.50	18.50	8.50	14.00	5.00	10.00	8.50	13.00
February.....	12.00	20.00	7.50	10.00	13.50	18.50	8.00	13.50	5.00	10.00	8.50	13.00
March.....	12.00	20.00	7.50	11.50	13.50	18.00	7.50	11.50	5.00	10.00	8.50	13.00
April.....	12.00	20.00	6.50	12.50	13.00	18.00	7.50	14.00	5.00	10.00	8.50	13.00
May.....	12.00	20.00	6.00	14.00	12.50	18.00	8.25	14.00	5.00	10.00	8.50	13.00
June.....	12.00	20.00	6.50	14.00	12.50	18.00	8.25	13.50	5.00	10.00	8.50	13.00
July.....	12.00	20.00	7.00	14.00	12.00	18.00	8.25	13.50	5.00	10.00	8.50	13.00
August.....	12.00	20.00	7.50	14.00	12.00	18.00	8.25	13.50	5.00	10.00	8.50	13.00
September.....	12.00	20.00	7.50	14.00	12.00	18.00	8.00	10.25	5.00	10.00	8.50	13.00
October.....	12.00	20.00	8.00	12.50	12.00	18.00	8.00	10.25	5.00	10.00	8.50	13.00
November.....	12.00	18.50	7.00	12.00	12.00	18.00	8.00	10.25	5.00	10.00	8.50	13.00
December.....	12.00	18.50	7.50	12.50	12.00	18.00	8.00	10.25	5.00	10.00	8.50	13.00
Year.....	12.00	20.00	6.00	14.00	12.00	18.50	7.50	14.00	5.00	10.00	8.50	13.00
1910.												
January.....	9.50	16.75	6.00	12.00	11.50	16.75	8.00	10.25	5.00	10.00	8.50	13.00
February.....	9.50	16.75	7.00	13.50	11.25	16.25	8.00	13.50	5.00	10.00	8.50	13.00
March.....	9.50	16.75	7.50	17.00	11.50	16.25	8.75	15.00	5.00	10.00	8.50	13.00
April.....	9.50	16.75	5.50	17.00	11.50	16.25	9.50	15.00	5.00	10.00	8.50	13.00
May.....	9.50	16.75	8.00	17.00	11.50	16.25	9.50	15.00	5.00	10.00	8.50	13.00
June.....	9.50	16.75	9.00	17.50	12.00	16.25	9.50	16.50	5.00	10.00	8.50	13.00
July.....	9.50	16.75	9.50	17.00	12.50	17.00	10.00	16.50	5.00	10.00	8.50	13.00
August.....	9.50	16.75	8.50	12.00	12.50	17.00	10.00	16.50	5.00	10.00	8.50	13.00
September.....	9.50	16.75	Nominal.		12.50	17.00	10.00	14.50	5.00	10.00	8.50	13.00
October.....	9.50	16.75	8.50	12.00	11.50	17.00	9.50	13.00	5.00	10.00	8.50	13.00
November.....	7.50	14.00	8.50	11.00	8.00	12.50	9.50	13.00	5.00	10.00	8.50	13.00
December.....	7.00	14.00	8.50	11.50	8.00	12.50	9.50	13.00	5.00	10.00	8.50	13.00
Year.....	7.00	16.75	6.00	17.50	8.00	17.00	8.00	16.50	5.00	10.00	8.50	13.00
1911.												
January.....	5.50	14.00	7.00	13.50	8.00	12.75	9.50	13.00	5.00	10.00	8.50	13.00
February.....	5.50	13.00	7.00	18.00	6.50	12.00	9.50	13.00	6.00	12.00	8.50	13.00
March.....	5.50	13.00	8.00	18.00	6.50	12.00	9.50	15.50	6.00	12.00	8.50	13.00
April.....	5.50	13.00	8.00	17.50	6.50	12.00	9.50	15.50	6.00	12.00	8.50	13.00
May.....	5.50	13.00	8.00	17.50	6.00	12.00	9.50	15.50	6.00	12.00	8.50	13.00
June.....	5.50	13.00	9.50	17.00	6.00	12.00	9.50	15.50	6.00	12.00	8.50	13.00
July.....	5.50	13.00	9.50	17.00	6.50	12.00	9.50	15.50	6.00	12.00	8.50	13.00
August.....	6.25	14.50	9.50	15.00	6.50	12.50	9.50	15.50	6.00	12.00	8.50	13.00
September.....	6.25	14.50	9.50	15.00	6.50	12.50	9.50	15.50	6.00	12.00	8.50	13.00
October.....	6.25	14.50	9.00	13.50	6.50	12.00	9.50	13.50	6.00	12.00	8.50	13.00
November.....	6.25	14.50	9.00	13.50	6.50	12.25	9.50	13.50	6.00	12.00	8.50	13.00
December.....	6.25	14.50	8.50	12.50	6.75	12.50	9.50	13.50	6.00	12.00	8.50	13.00
Year.....	5.50	14.50	7.00	18.00	6.00	12.75	9.50	15.50	5.00	12.00	8.50	13.00
1912.												
January.....	6.00	13.00	8.00	14.00	7.50	10.50	9.50	13.50	6.00	12.00	8.50	13.00
February.....	6.00	13.00	8.00	14.00	7.50	12.00	9.50	13.50	6.00	12.00	8.50	13.00
March.....	6.00	13.00	8.00	14.00	8.00	12.00	9.50	13.50	6.00	12.00	8.50	13.00
April.....	6.00	13.00	8.00	15.00	7.50	12.00	9.50	15.00	6.00	12.00	8.50	13.00
May.....	6.00	13.00	8.00	16.00	7.50	12.00	9.50	15.00	6.00	12.00	8.50	13.00
June.....	6.00	13.00	9.50	16.00	7.50	12.00	9.50	15.00	6.00	12.00	8.50	13.00
July.....	5.00	14.00	9.00	16.00	7.00	12.00	9.50	15.00	6.00	12.00	8.50	13.00
August.....	5.00	14.00	9.00	15.00	7.00	12.00	9.50	14.50	6.00	12.00	8.50	13.00
September.....	5.00	14.00	9.00	15.00	7.00	12.00	9.50	14.50	6.00	12.00	8.50	13.00
October.....	5.00	14.00	9.00	14.00	7.00	12.00	9.50	14.50	6.00	12.00	8.50	15.00
November.....	5.00	14.00	9.00	14.00	7.00	13.00	9.50	14.50	6.00	12.00	8.50	15.00
December.....	5.00	14.00	9.00	14.00	7.50	13.00	9.50	13.00	6.00	12.00	8.50	15.00
Year.....	5.00	14.00	8.00	16.00	7.00	13.00	9.50	15.00	6.00	12.00	8.50	15.00

TABLE 96.—*International trade in unmanufactured tobacco, calendar years 1907–1911.*[Tobacco comprises leaf, stems, strippings, and *tombac*, but not snuff. See "General note," p. 564.]

## EXPORTS.

Country.	1907	1908	1909	1910	1911
	<i>Pounds.</i>	<i>Pounds.</i>	<i>Pounds.</i>	<i>Pounds.</i>	<i>Pounds.</i>
Aden <sup>1</sup> .....	6,587,956	6,825,265	5,939,803	<sup>2</sup> 5,939,803	<sup>2</sup> 5,939,803
Algeria.....	7,754,680	4,073,439	<sup>3</sup> 8,655,360	<sup>3</sup> 13,511,773	<sup>3</sup> 13,426,455
Austria-Hungary.....	21,637,488	21,044,230	21,456,931	24,903,382	24,072,689
Brazil.....	65,458,948	33,650,715	64,654,476	<sup>3</sup> 75,284,398	<sup>3</sup> 40,761,118
British India.....	28,787,031	19,006,506	17,195,391	24,515,681	34,560,174
Bulgaria.....	2,678,380	5,532,045	4,347,506	5,233,789	4,812,382
Ceylon.....	4,425,619	4,075,075	6,077,221	1,543,920	4,097,520
Cuba.....	19,135,347	40,111,922	49,468,425	34,822,228	<sup>3</sup> 34,822,228
Dutch East Indies.....	156,809,019	177,855,168	127,133,401	138,571,385	<sup>3</sup> 170,226,297
Greece.....	14,965,568	10,786,972	13,159,838	12,659,828	18,629,114
Mexico.....	4,479,908	3,884,417	2,837,311	1,231,928	<sup>4</sup> 1,231,928
Netherlands.....	5,163,874	3,750,461	4,232,501	3,843,420	3,713,177
Paraguay.....	3,405,349	10,921,919	<sup>3</sup> 10,767,680	<sup>3</sup> 11,282,772	<sup>4</sup> 11,282,772
Persia <sup>5</sup> .....	3,875,093	2,929,637	4,555,765	<sup>2</sup> 4,555,765	<sup>2</sup> 4,555,765
Philippine Islands.....	23,589,657	24,927,663	20,976,743	21,926,744	27,656,358
Russia.....	14,246,861	17,117,323	20,610,622	20,891,616	22,950,226
Santo Domingo.....	21,802,982	18,665,594	24,822,623	22,262,108	30,441,476
Turkey <sup>6</sup> .....	<sup>7</sup> 39,267,984	<sup>6</sup> 65,600,000	<sup>7</sup> 77,800,000	<sup>7</sup> 77,800,000	<sup>7</sup> 77,800,000
United States.....	317,399,986	305,455,871	351,564,177	328,562,036	370,283,512
Other countries.....	11,232,000	17,134,000	15,514,000	18,163,000	<sup>3</sup> 26,833,000
Total.....	772,703,730	793,348,222	851,769,774	847,505,576	928,095,994

## IMPORTS.

Aden <sup>1</sup> .....	9,217,012	8,842,225	8,988,786	<sup>2</sup> 8,988,786	<sup>2</sup> 8,988,786
Argentina.....	8,689,607	10,500,693	11,756,931	12,431,627	14,046,649
Australia.....	10,169,916	12,886,746	9,370,516	13,586,845	14,900,520
Austria-Hungary.....	36,349,224	43,907,916	48,820,867	53,311,196	50,428,902
Belgium.....	20,158,252	20,926,828	21,194,579	20,994,432	20,694,712
British India.....	4,993,124	6,607,385	7,514,446	6,583,970	5,196,380
Canada.....	17,338,976	16,760,080	12,654,798	16,674,292	17,814,612
China.....	17,770,000	11,234,933	8,273,200	13,662,267	13,026,400
Denmark.....	11,208,186	19,896,515	3,306,900	9,272,768	10,674,012
Egypt.....	18,800,829	19,147,628	18,753,130	18,103,095	19,007,722
Finland.....	9,834,255	9,561,348	9,477,672	9,384,259	9,376,830
France.....	62,556,784	63,594,310	44,485,742	61,265,614	<sup>3</sup> 61,189,114
Germany.....	156,696,575	170,492,741	172,018,104	146,926,890	162,019,581
Italy.....	43,913,427	44,892,711	49,666,772	41,454,417	43,459,941
Netherlands.....	50,171,539	47,963,304	52,343,677	55,045,754	57,265,903
Norway.....	3,877,054	3,648,437	3,700,179	4,141,628	3,730,800
Portugal.....	5,713,117	5,160,058	6,990,132	5,701,360	<sup>4</sup> 5,701,360
Southern Nigeria.....	5,789,775	4,563,355	6,042,225	5,956,604	5,060,750
Spain.....	51,055,075	31,920,895	40,997,520	44,337,800	48,331,123
Sweden.....	9,212,040	9,165,893	9,135,007	9,438,252	10,054,186
Switzerland.....	17,561,182	16,721,450	16,542,877	17,149,804	18,154,220
United Kingdom.....	87,329,290	87,933,057	85,654,211	88,141,019	91,236,859
United States.....	34,088,288	37,665,211	44,221,940	42,443,323	52,901,433
Other countries.....	40,834,000	48,339,000	48,079,000	43,720,000	<sup>3</sup> 42,504,000
Total.....	733,327,527	752,332,719	739,989,211	748,616,002	786,364,795

<sup>1</sup> Year beginning April 1.<sup>2</sup> Data for 1909.<sup>3</sup> Preliminary.<sup>4</sup> Year preceding.<sup>5</sup> Year beginning March 21.<sup>6</sup> Year beginning March 14.<sup>7</sup> Data for 1900.<sup>8</sup> Unofficial estimate.

## FLAX.

TABLE 97.—*Flax area of countries named, 1909–1911.*

Country.	1909	1910	1911
<b>NORTH AMERICA.</b>			
United States.....	<i>Acres.</i> 2,083,100	<i>Acres.</i> 2,467,000	<i>Acres.</i> 2,757,000
Canada:			
Quebec.....			1,700
Ontario.....			8,400
Manitoba.....	22,400	24,600	62,200
Saskatchewan.....	110,300	438,000	570,000
Alberta.....	5,800	14,300	40,300
Total.....			682,600
Mexico.....	(1)	(1)	(1)
<b>SOUTH AMERICA.</b>			
Argentina.....	3,791,300	3,596,800	3,715,900
Uruguay.....	45,300	(1)	94,700
Total.....	3,836,600		3,810,600
<b>EUROPE.</b>			
Austria-Hungary:			
Austria.....	111,100	95,900	94,900
Hungary proper.....	23,400	21,100	(1)
Croatia-Slavonia.....	(1)	(1)	(1)
Bosnia-Herzegovina.....	(1)	(1)	(1)
Belgium.....	39,300	(1)	(1)
Bulgaria.....	400	900	1,200
France.....	50,500	53,600	59,400
Italy.....	22,200	22,400	21,800
Netherlands.....	24,800	29,000	38,800
Roumania.....	30,100	33,100	52,200
Russia:			
Russia proper.....	3,120,200	3,047,500	3,237,300
Poland.....	90,600	88,300	95,500
Northern Caucasia.....	63,300	80,000	96,000
Total Russia (European).....	3,274,100	3,215,800	3,428,800
Servia.....	3,000	4,300	4,500
Sweden.....	4,200	(1)	3,800
Ireland.....	38,100	66,600	54,900
<b>ASIA.</b>			
British India.....	2,997,000	3,188,100	3,757,300
Russia:			
Central Asia.....	176,600	91,200	125,500
Siberia.....	128,800	137,200	154,100
Transcaucasia.....	(2)	(2)	(2)
Total Russia (Asiatic).....	305,400	228,400	279,600
<b>AFRICA.</b>			
Algeria.....	1,000	500	1,800

<sup>1</sup> No official data.<sup>2</sup> Less than 100 acres.

TABLE 98.—*Flax crop of countries named, 1909–1911.*

Country.	Seed.			Fiber.		
	1909	1910	1911	1909	1910	1911
<b>NORTH AMERICA.</b>						
United States.....	<i>Bushels.</i> 19,513,000	<i>Bushels.</i> 12,718,000	<i>Bushels.</i> 19,370,000	<i>Pounds.</i>	<i>Pounds.</i>	<i>Pounds.</i>
Canada:						
Quebec.....			19,000			
Ontario.....			118,000			
Manitoba.....	317,000	290,000	899,000			
Saskatchewan.....	1,787,000	3,448,000	6,413,000			
Alberta.....	109,000	64,000	418,000			
Total.....	2,213,000	3,802,000	7,867,000			
Mexico.....	150,000	150,000	150,000			
Total North America.....	21,876,000	16,670,000	27,387,000			
<b>SOUTH AMERICA.</b>						
Argentina.....	41,291,000	28,212,000	23,424,000			
Uruguay.....	522,000	600,000	660,000			
Total.....	41,813,000	28,812,000	24,084,000			
<b>EUROPE.</b>						
Austria-Hungary:						
Austria.....	852,000	663,000	697,000	68,136,000	50,191,000	46,646,000
Hungary proper.....	186,000	164,000	170,000	20,118,000	18,492,000	19,000,000
Croatia-Slavonia.....	30,000	30,000	30,000	9,000,000	8,143,000	8,000,000
Bosnia-Herzegovina..	4,000	4,000	4,000	1,400,000	1,000,000	1,000,000
Total Austria-Hungary.....	1,072,000	861,000	901,000	98,654,000	77,826,000	74,646,000
Belgium.....	300,000	300,000	300,000	27,000,000	28,000,000	28,000,000
Bulgaria.....	2,000	8,000	10,000	200,000	709,000	800,000
France.....	436,000	416,000	496,000	30,494,000	33,106,000	45,004,000
Italy.....	281,000	232,000	341,000	7,242,000	6,883,000	6,078,000
Netherlands.....	219,000	316,000	374,000	13,438,000	14,189,000	20,929,000
Roumania.....	205,000	363,000	603,000	1,628,000	4,448,000	4,000,000
Russia:						
Russia proper.....	19,767,000	16,743,000	18,877,000	1,022,484,000		
Poland.....	948,000	816,000	935,000	42,450,000		
Northern Cascaia.....	583,000	590,000	732,000	26,130,000		
Total Russia (European).....	21,298,000	18,149,000	20,544,000	1,091,064,000	702,477,000	1,034,000,000
Servia.....				872,000	2,192,000	2,091,000
Sweden.....	21,000	20,000	17,000	1,449,000	1,400,000	1,500,000
Ireland.....				16,081,000	19,882,000	25,179,000
Total.....	23,834,000	20,665,000	23,586,000	1,288,122,000	891,112,000	1,242,227,000
<b>ASIA.</b>						
British India.....	11,552,000	17,112,000	22,544,000			
Russia:						
Central Asia.....	966,000	429,000	220,000	51,864,000		
Siberia.....	771,000	832,000	785,000	38,109,000		
Transcaucasia.....	( <sup>2</sup> )	( <sup>2</sup> )	( <sup>2</sup> )	6,429,000		
Total Russia (Asiatic).....	1,737,000	1,261,000	1,005,000	96,402,000	( <sup>3</sup> )	49,000,000
Total Asia.....	13,289,000	18,373,000	23,549,000	96,402,000		49,000,000
<b>AFRICA.</b>						
Algeria.....	8,000	4,000	16,000			
Grand total.....	100,820,000	84,524,000	98,622,000	1,384,524,000	891,112,000	1,291,227,000

<sup>1</sup> Includes Asiatic Russia.<sup>2</sup> Less than 1,000 bushels.<sup>3</sup> Included in European Russia.

TABLE 99.—Total production of flax (seed and fiber) in countries named in Table 98, 1896–1911.

Year.	Production.		Year.	Production.	
	Seed.	Fiber.		Seed.	Fiber.
	<i>Bushels.</i>	<i>Pounds.</i>		<i>Bushels.</i>	<i>Pounds.</i>
1896.....	82,684,500	1,714,205,000	1904.....	107,743,000	1,517,922,000
1897.....	57,596,500	1,498,054,000	1905.....	100,458,000	1,494,229,000
1898.....	72,938,500	1,780,693,000	1906.....	88,165,000	1,871,723,000
1899.....	66,347,600	1,138,763,000	1907.....	102,960,000	2,042,390,000
1900.....	62,431,500	1,315,931,000	1908.....	100,850,000	1,907,591,000
1901.....	72,314,000	1,050,260,000	1909.....	100,820,000	1,384,524,000
1902.....	83,891,000	1,564,840,000	1910.....	84,524,000	891,112,000
1903.....	110,455,000	1,492,383,000	1911.....	98,622,000	1,291,227,000

TABLE 100.—Acreage, production, value, etc., of flaxseed, United States, 1849–1912.

Year.	Acreage sown and harvested.	Average yield per acre.	Production.	Average farm price Dec. 1.	Farm value Dec. 1.	Condition of growing crop.			
						July 1.	Aug. 1.	Sept. 1.	When harvested.
	<i>Acres.</i>	<i>Bushels.</i>	<i>Bushels.</i>	<i>Cents.</i>	<i>Dollars.</i>	<i>P. ct.</i>	<i>P. ct.</i>	<i>P. ct.</i>	<i>P. ct.</i>
1849 <sup>1</sup> .....			562,000						
1859 <sup>1</sup> .....			567,000						
1869 <sup>1</sup> .....			1,730,000						
1879 <sup>1</sup> .....			7,170,000						
1889 <sup>1</sup> .....	1,319,000	7.8	10,250,000						
1899 <sup>1</sup> .....	2,111,000	9.5	19,979,000						
1902.....	3,740,000	7.8	29,285,000	105.0	30,815,000				
1903.....	3,233,000	8.4	27,301,000	81.7	22,292,000	86.2	80.3	80.5	74.0
1904.....	2,264,000	10.3	23,401,000	99.3	23,229,000	86.6	78.9	85.8	87.0
1905.....	2,535,000	11.2	26,478,000	84.4	24,049,000	92.7	96.7	94.2	91.5
1906.....	2,506,000	10.2	25,576,000	101.3	25,899,000	93.2	92.2	89.0	87.4
1907.....	2,864,000	9.0	25,851,000	95.6	24,713,000	91.2	91.9	85.4	78.0
1908.....	2,679,000	9.6	25,805,000	118.4	30,577,000	92.5	86.1	82.5	81.2
1909.....	2,742,000	9.4	25,856,000	152.6	39,466,000	95.1	92.7	88.9	84.9
1909 <sup>1</sup> .....	2,083,000	9.4	19,513,000						
1910 <sup>2</sup> .....	2,467,000	5.2	12,718,000	231.7	29,472,000	65.0	51.7	48.3	47.2
1911 <sup>2</sup> .....	2,757,000	7.0	19,370,000	182.1	35,272,000	80.9	71.0	68.4	69.6
1912.....	2,851,000	9.8	28,073,000	114.7	32,202,000	88.9	87.5	86.3	83.8

<sup>1</sup> Census.

<sup>2</sup> Figures adjusted to census basis.

TABLE 101.—Acreage, production, and value of flaxseed, by States, 1912.

State.	Acreage.	Average yield per acre.	Production.	Average farm price Dec. 1.	Value per acre Dec. 1.	Farm value Dec. 1.
Wisconsin.....	10,000	12.5	125,000	1.27	15.88	159,000
Minnesota.....	404,000	10.2	4,121,000	1.20	12.24	4,945,000
Iowa.....	35,000	11.5	402,000	1.24	14.26	498,000
Missouri.....	12,000	6.0	72,000	1.10	6.60	79,000
North Dakota.....	1,246,000	9.7	12,086,000	1.14	11.06	13,778,000
South Dakota.....	619,000	8.6	5,323,000	1.13	9.72	6,015,000
Nebraska.....	2,000	9.5	19,000	1.28	12.16	24,000
Kansas.....	50,000	6.0	300,000	1.30	7.80	390,000
Oklahoma.....	1,000	9.0	9,000	1.38	12.42	12,000
Montana.....	460,000	12.0	5,520,000	1.12	13.44	6,182,000
Colorado.....	12,000	8.0	96,000	1.25	10.00	120,000
United States.....	2,851,000	9.8	28,073,000	1.147	11.29	32,202,000

TABLE 102.—Farm price of flaxseed per bushel, on first of each month, 1911-12.

Month.	United States.		North Central States east of Mississippi River.		North Central States west of Mississippi River.		Far Western States.	
	1912	1911	1912	1911	1912	1911	1912	1911
January.....	Cents. 187.1	Cents. 221.1	Cents. 190.0	Cents. 215.0	Cents. 184.0	Cents. 221.0	Cents. ....	Cents. ....
February.....	190.8	233.9	188.0	240.0	191.0	234.0	190.0	.....
March.....	183.9	240.7	195.0	250.0	186.0	240.0	171.0	.....
April.....	191.3	234.6	200.0	285.0	189.0	234.0	200.0	.....
May.....	181.0	241.9	212.0	240.0	199.0	242.0	215.0	.....
June.....	205.0	225.0	215.0	250.0	205.0	225.0	.....	.....
July.....	198.4	205.6	188.0	219.0	198.0	205.0	.....	.....
August.....	175.2	199.2	188.0	193.0	175.0	198.0	175.0	210.0
September.....	162.6	203.6	192.0	202.0	163.0	203.0	160.0	210.0
October.....	147.7	205.0	178.0	223.0	148.0	205.0	.....	202.0
November.....	133.4	210.6	.....	210.0	133.0	211.0	.....	.....
December.....	114.7	182.1	127.0	185.0	115.0	182.0	112.0	180.0

TABLE 103.—Wholesale price of flaxseed per bushel, 1898-1912.

Date.	St. Louis.		Cincinnati.		Chicago.		Milwaukee.		Duluth.	
	Prime.		Low.	High.	No. 1 and No. 1 Northwestern.		No. 1 North-western.		Low.	High.
	Low.	High.			Low.	High.	Low.	High.		
1899.....	\$0.93	\$1.46	\$0.90	\$1.00	\$0.96½	\$1.51	\$0.99	\$1.52	\$0.90	\$1.42
1900.....	1.25	1.78	1.00	1.45	1.32	1.86	1.30	1.86	1.28½	1.87
1901.....	1.37	1.72	1.20	1.50	1.38	1.90	1.30	1.88	1.33	1.88
1902.....	1.11	1.65	1.25	1.40	1.13	1.80	1.18	1.80	1.15½	1.78
1903.....	.86	1.17	1.00	1.30	.89	1.24	.94	1.24	.92	1.20
1904.....	.92½	1.18½	1.00	1.00	.97	1.28	1.06	1.28	1.01½	1.28
1905.....	.90	1.30	1.10	1.10	.92	1.47	.98	1.47	.96½	1.50
1906.....	.98	1.19	1.10	1.12	1.03	1.25	1.05	1.25	1.09½	1.25
1907.....	1.00	1.27	1.12	.....	.96	1.36½	1.07	1.34	1.06½	1.41½
1908.....	1.00	1.39½	1.12	1.25	1.06½	1.51½	1.12	1.47	1.12½	1.49½
1909.....										
January.....	1.42½	1.51	1.25	.....	1.44	1.61½	1.53½	1.62½	1.52	1.59
February.....	1.50	1.63	1.25	.....	1.50½	1.73½	1.60	1.71	1.58½	1.70
March.....	1.55	1.63	1.25	.....	1.52	1.71½	1.60½	1.70	1.61	1.68½
April.....	1.53	1.60	1.75	.....	1.53½	1.69½	1.66	1.70	1.63½	1.68½
May.....	1.53½	1.66½	1.75	.....	1.55	1.82	1.66½	1.80½	1.64½	1.82
June.....	1.50	1.65	1.75	.....	1.54½	1.71½	1.64	1.78½	1.75	1.81½
July.....	1.20	1.50	1.75	.....	1.29	1.65	1.40	1.66	1.39½	1.79
August.....	1.15	1.35	1.75	.....	1.35	1.45	1.35	1.45	1.38	1.50
September.....	1.32	1.38	1.75	.....	1.32½	1.51	1.40	1.50	1.37½	1.47
October.....	1.35	1.60	1.75	.....	1.32	1.73	1.42½	1.74½	1.36½	1.74½
November.....	1.55	1.72	1.75	.....	1.56	1.84½	1.68	1.84	1.66½	1.84½
December.....	1.68	1.90	1.75	.....	1.70	1.99	1.80	2.09	1.76½	2.04½
Year.....	1.15	1.90	1.25	.....	1.29	1.99	1.35	2.09	1.36½	2.04½
1910.....										
January.....	1.90	2.10	1.75	2.00	1.92	2.26	2.09	2.20	2.02	2.27
February.....	2.05	2.09	2.00	.....	2.04	2.22	2.13	2.21	2.15½	2.20½
March.....	2.08	2.24	2.00	.....	2.09½	2.35	2.18	2.35	2.17	2.35
April.....	2.18	2.30	2.00	.....	2.20	2.43½	2.32	2.45	2.32	2.46
May.....	.....	.....	2.00	2.75	1.94½	2.42½	1.96	2.40	2.08	2.38½
June.....	.....	.....	2.25	2.75	1.75	2.18	1.91½	2.20	1.89	2.20
July.....	1.80	2.18	2.25	2.75	1.97½	2.55	2.10	2.50	2.10	2.67
August.....	2.18	2.35	2.25	2.75	2.23	2.57½	2.40	2.55	2.42½	2.60
September.....	2.35	2.68	2.40	.....	2.21	2.84	2.36	2.75	2.34	2.84
October.....	2.30	2.54	2.40	2.50	2.29	2.70	2.39	2.68	2.41½	2.69
November.....	2.39	2.59	2.50	.....	2.37	2.73	2.52	2.70	2.50	2.74
December.....	2.25	2.43	2.50	.....	2.22½	2.57	2.32½	2.55	2.31½	2.54½
Year.....	1.80	2.68	1.75	2.75	1.75	2.84	1.91½	2.75	1.89	2.84

TABLE 103.—Wholesale price of flaxseed per bushel, 1898-1912—Continued.

Date.	St. Louis.		Cincinnati.		Chicago.		Milwaukee.		Duluth.	
	Prime.		Low.	High.	No. 1 and No. 1. Northwestern.		No. 1 North-western.		Low.	High.
	Low.	High.			Low.	High.	Low.	High.		
1911.										
January.....	\$2.35	\$2.58	\$2.50	\$2.50	\$2.37	\$2.70½	\$2.46	\$2.69	\$2.47	\$2.68½
February.....	2.56	2.60½	2.50	2.50	2.54	2.74½	2.64	2.70	2.63½	2.70
March.....	2.45	2.60	2.50	2.50	2.35½	2.69	2.44	2.67	2.46	2.67
April.....	2.46	2.57	2.50	2.50	2.39½	2.63½	2.48	2.62	2.48	2.62
May.....	2.28	2.60	2.50	2.75	2.25½	2.55	2.21	2.60	2.21	2.61
June.....	1.80	2.35	2.75	2.75	.....	.....	2.05	2.35	2.06	2.34
July.....	1.80	1.85	2.75	2.75	.....	.....	2.04	2.18	2.05	2.19
August.....	1.82	2.00	2.75	2.75	2.35	2.57	2.08	2.52	2.10	2.52
September.....	2.25	2.40	.....	.....	2.27	2.69½	2.28	2.62	2.27½	2.65
October.....	2.15	2.43	.....	.....	2.13	2.47	2.11½	2.46	2.12	2.47
November.....	1.98	2.17	.....	.....	1.93	2.17	1.92	2.18	1.93	2.17½
December.....	2.00	2.14	.....	.....	1.94	2.16	2.03	2.13	1.94	2.18
Year.....	1.80	2.60½	2.50	2.75	1.93	2.74½	1.92	2.70	1.93	2.70
1912.										
January.....	2.09	2.17	.....	.....	2.10	2.20	2.10	2.19	2.10	2.22
February.....	2.01	2.11	2.50	2.50	2.01	2.12	2.02½	2.10½	2.00	2.13½
March.....	2.03	2.13	2.50	2.50	2.02	2.14	2.01½	2.13	2.00½	2.13½
April.....	2.13	2.18	2.50	2.50	2.14	2.18½	2.13½	2.18½	2.14½	2.18½
May.....	2.13	2.21	2.50	2.50	2.16½	2.19½	2.15	2.31	2.17	2.53
June.....	2.05	2.05	2.56	2.56	.....	.....	2.24	2.39	2.20	2.36½
July.....	1.55	1.75	2.80	2.80	.....	.....	1.79	2.18½	1.80	2.20½
August.....	1.52	1.70	2.80	2.80	.....	.....	1.71	2.03	1.72½	2.00
September.....	1.56	1.64	.....	.....	.....	.....	1.68	1.89	1.67	1.85
October.....	1.35	1.58	.....	.....	1.65	1.74½	1.45½	1.75	1.49	1.74½
November.....	1.21	1.31	.....	.....	1.28	1.43	1.27	1.47½	1.27	1.44
December.....	1.18	1.23	1.50	1.50	.....	.....	1.24½	1.30½	1.22	1.26½
Year.....	1.18	2.21	1.50	2.80	1.28	2.20	1.24½	2.39	1.22	2.53

RICE.

TABLE 104.—Rice crop of countries named, 1907-1911.

[Mostly cleaned rice. The United States crop as given here is computed from the official returns, which are for rough rice, allowing 45 pounds rough to 1 bushel, and 162 pounds rough to 100 pounds cleaned. No data for Afghanistan, Algeria, Colombia, Federated Malay States, Persia, Trinidad and Tobago, Venezuela, and a few other countries of small production.]

Country.	1907	1908	1909	1910	1911
NORTH AMERICA.					
United States:					
Continous.....	Pounds. 520,000,000	Pounds. 608,056,000	Pounds. 676,889,000	Pounds. 680,833,000	Pounds. 637,056,000
Noncontiguous— Hawaii.....	1 33,400,000	1 33,400,000	25,820,000	2 25,820,000	2 25,820,000
Total United States (except Philippine Is- lands).....	553,400,000	641,456,000	702,709,000	706,653,000	662,876,000
Central America:					
Guatemala 3.....	1,300,000	1,300,000	1,300,000	1,300,000	1,300,000
Honduras 4.....	8,100,000	8,100,000	8,100,000	8,100,000	8,100,000
Mexico.....	5 69,932,000	5 69,932,000	5 69,932,000	124,900,000	6 124,900,000
Total.....	632,732,000	720,788,000	782,041,000	840,953,000	797,176,000

1 Census, 1899.  
2 Census, 1909.

3 Data for 1904.  
4 Data for 1901.

5 Data for 1906.  
6 Year preceding.



TABLE 104.—*Rice crop of countries named, 1907-1911—Continued.*

Country.	1907	1908	1909	1910	1911
<b>SOUTH AMERICA.</b>					
	<i>Pounds.</i>	<i>Pounds.</i>	<i>Pounds.</i>	<i>Pounds.</i>	<i>Pounds.</i>
Argentina.....	17,808,000	119,000,000	219,000,000	219,000,000	219,000,000
Brazil: São Paulo.....	383,000,000	383,000,000	84,868,000	184,704,000	4184,704,000
British Guiana.....	159,000,000	71,300,000	91,000,000	591,000,000	591,000,000
Dutch Guiana.....	3,331,000	3,718,000	4,326,000	4,376,000	4,376,000
Peru.....	209,500,000	119,756,000	53,074,000	114,313,000	4114,313,000
Total.....	372,639,000	296,774,000	252,268,000	413,393,000	413,393,000
<b>EUROPE.</b>					
Bulgaria.....	7,758,000	6,336,000	11,426,000	10,240,000	6,666,000
France.....		2,790,000	1,883,000	1,437,000	41,437,000
Greece <sup>6</sup> .....	2,900,000	2,900,000	2,900,000	2,900,000	2,900,000
Italy.....	796,000,000	716,000,000	647,000,000	596,059,000	652,153,000
Spain.....	293,479,000	277,619,000	282,065,000	287,303,000	4287,303,000
Turkey, European <sup>7</sup> .....	1,387,000	1,387,000	1,387,000	1,387,000	1,387,000
Total.....	1,101,524,000	1,007,032,000	946,661,000	899,326,000	951,846,000
<b>ASIA.</b>					
British India: <sup>8</sup>					
British Provinces.....	60,729,000,000	61,306,000,000	84,526,000,000	84,560,000,000	79,112,000,000
Native States <sup>1</sup> .....	739,000,000	1,602,000,000	2,186,000,000	2,186,000,000	52,186,000,000
Total British India.....	61,468,000,000	62,908,000,000	86,712,000,000	86,746,000,000	81,298,000,000
Ceylon.....	333,000,000	309,000,000	320,000,000	5320,000,000	5320,000,000
China: Hu-nan, Kiang-si, Mukden, and Yün-nan.....	47,204,000,000	47,204,000,000	47,204,000,000	47,204,000,000	47,204,000,000
Chosen (Korea) <sup>10</sup> .....	3,200,000,000	3,200,000,000	3,200,000,000	3,200,000,000	3,200,000,000
Formosa.....	1,409,000,000	1,454,000,000	1,446,000,000	1,329,000,000	41,329,000,000
French Indo-China <sup>6</sup> .....	5,000,000,000	5,000,000,000	5,000,000,000	5,000,000,000	5,000,000,000
Japan.....	15,317,905,000	16,217,500,000	16,375,000,000	14,800,000,000	16,240,000,000
Java and Madura.....	6,877,000,000	7,276,000,000	7,566,000,000	7,566,000,000	7,566,000,000
Philippine Islands.....	695,000,000	568,000,000	1,018,000,000	1,104,000,000	1,201,000,000
Russia, Asiatic: Caucasus and Central Asia.....	393,000,000	290,000,000	372,000,000	363,000,000	4363,000,000
Siam <sup>6</sup> .....	6,824,000,000	6,824,000,000	6,824,000,000	6,824,000,000	6,824,000,000
Straits Settlements <sup>1</sup> .....	79,000,000	77,000,000	77,000,000	77,000,000	77,000,000
Turkey, Asiatic <sup>7</sup> .....	137,230,000	137,230,000	137,230,000	137,230,000	137,230,000
Total.....	148,937,135,000	151,464,730,000	176,251,230,000	174,670,230,000	170,759,230,000
<b>AFRICA.</b>					
Egypt <sup>1</sup> .....	557,124,000	577,379,000	653,458,000	663,557,000	523,438,000
Madagascar.....	2953,000,000	953,000,000	2953,000,000	2953,000,000	2953,000,000
Nyassaland <sup>11</sup> .....	1,978,000	1,600,000	1,900,000	1,900,000	1,900,000
Total.....	1,512,102,000	1,531,979,000	1,608,358,000	1,618,457,000	1,478,338,000
<b>OCEANIA.</b>					
Fiji <sup>1</sup> .....	2,000,000	3,000,000	5,000,000	5,000,000	5,000,000
Grand total.....	152,558,132,000	155,024,303,000	179,845,558,000	178,447,359,000	174,404,983,000

<sup>1</sup> Estimated from official returns for acreage.<sup>2</sup> Data for 1908.<sup>3</sup> Official report for crop of 1904-5.<sup>4</sup> Year preceding.<sup>5</sup> Data for 1909.<sup>6</sup> Average production as unofficially estimated.<sup>7</sup> Data for European and Asiatic Turkey include 29 provinces and arrondissements only.<sup>8</sup> Data for British India refer to crop years beginning in the spring of the calendar years mentioned in this table. Production as given here estimated unofficially for the entire country on the basis of official returns for about 70 per cent of the area harvested.<sup>9</sup> Data for 1910.<sup>10</sup> Estimated from official returns of exports of this country and from per capita consumption of rice in Japan, 1894-1903, including food, seed, and waste, but not including rice used for saké (270 pounds per annum).<sup>11</sup> Includes only crops raised by natives.

TABLE 105.—Total production of rice in countries named in Table 104, 1900–1911.<sup>1</sup>

Year.	Production.	Year.	Production.
	<i>Pounds.</i>		<i>Pounds.</i>
1900.....	91,584,400,000	1906.....	112,363,176,000
1901.....	99,445,600,000	1907.....	152,558,132,000
1902.....	106,626,400,000	1908.....	155,024,303,000
1903.....	110,865,000,000	1909.....	179,845,558,000
1904.....	115,735,800,000	1910.....	178,447,359,000
1905.....	108,963,551,000	1911.....	174,404,983,000

<sup>1</sup> China not included prior to 1907.

TABLE 106.—Acreage, production, value, etc., of rice, United States, 1904–1912.

Year.	Acreage sown and harvested.	Average yield per acre.	Production.	Average farm price Dec. 1.	Farm value Dec. 1.	Condition of growing crop.			
						July 1.	Aug. 1.	Sept. 1.	When harvested.
	<i>Acres.</i>	<i>Bushels.</i>	<i>Bushels.</i>	<i>Cents.</i>	<i>Dollars.</i>	<i>Per ct.</i>	<i>Per ct.</i>	<i>Per ct.</i>	<i>Per ct.</i>
1904.....	662,000	31.9	21,096,000	65.8	13,892,000	88.2	90.2	89.7	87.3
1905.....	460,000	28.1	12,933,000	95.0	12,286,000	88.0	92.9	92.2	89.3
1906.....	575,000	31.1	17,855,000	90.3	16,121,000	82.9	83.1	86.8	87.2
1907.....	627,000	29.9	18,738,000	85.8	16,081,000	88.7	88.6	87.0	88.7
1908.....	655,000	33.4	21,890,000	81.2	17,771,000	92.9	94.1	93.5	87.7
1909.....	720,000	33.8	24,368,000	79.4	19,341,000	90.7	84.5	84.7	81.2
1910.....	723,000	33.9	24,510,000	67.8	16,624,000	86.3	87.6	88.8	88.1
1911.....	696,000	32.9	22,934,000	79.7	18,274,000	87.7	88.3	87.2	85.4
1912.....	722,800	34.7	25,054,000	93.5	23,423,000	86.3	86.3	88.8	89.2

TABLE 107.—Acreage, production, value, etc., of rice, by States, 1912.

State.	Acreage.	Average yield per acre.	Production.	Average farm price Dec. 1.	Value per acre Dec. 1.	Farm value Dec. 1.
	<i>Acres.</i>	<i>Bushels.</i>	<i>Bushels.</i>	<i>Cents.</i>	<i>Dollars.</i>	<i>Dollars.</i>
North Carolina.....	400	25.0	10,000	90	22.50	9,000
South Carolina.....	8,000	25.0	200,000	93	23.25	186,000
Georgia.....	900	30.0	27,000	90	27.00	24,000
Florida.....	600	25.0	15,000	90	22.50	14,000
Alabama.....	300	30.0	9,000	90	27.00	8,000
Mississippi.....	2,200	35.0	77,000	90	31.50	69,000
Louisiana.....	352,600	33.5	11,812,000	93	31.16	10,985,000
Texas.....	265,600	35.5	9,429,000	94	33.37	8,803,000
Arkansas.....	90,800	37.5	3,405,000	94	35.25	3,201,000
California.....	1,400	50.0	70,000	91	45.50	64,000
United States.....	722,800	34.7	25,054,000	93.5	32.41	23,423,000

TABLE 108.—Wholesale price of rice per pound, 1899-1912.

Date.	New York.		Cincinnati.		Lake Charles.		New Orleans.		Houston.	
	Domestic (good).		Prime. <sup>1</sup>		Rough. <sup>2</sup>		Honduras, cleaned.		Head rice, cleaned.	
	Low.	High.	Low.	High.	Low.	High.	Low.	High.	Low.	High.
	Cents.	Cents.	Cents.	Cents.	Dolls.	Dolls.	Cents.	Cents.	Cents.	Cents.
1899.....	4½	5½	5½	6½			3½	6½		
1900.....	4½	5	5½	6	1.70	3.50	3½	6½	3	5
1901.....	4½	5	5½	6	1.75	3.40	1½	6½	3½	5½
1902.....	4½	5½	5½	6½	1.50	3.60	1½	6½	4	6½
1903.....	4½	5½	4½	5½	1.00	3.00	1½	5½	3	4½
1904.....	3½	4½	3½	5½	1.00	3.85	1½	5½	3	5
1905.....	3½	4½	3	5½	2.00	3.85	1½	6	3½	5½
1906.....	4½	5½	4½	5½	1.75	4.10	1½	6½	4	6½
1907.....	5	6	4½	6	1.75	4.33	1½	7½	4½	6½
1908.....	5	6½	6½	7½						
1909.										
January.....	5	5½	Fancy head.		1.75	3.75	1½	6	4½	5½
February.....	5½	5½	6½	7	2.00	3.63	1½	6½	4½	5½
March.....	5½	6½	6½	7	2.25	3.63	6	6½	4½	5½
April.....	5½	5½	6½	7	2.25	3.60	2	6	5	5½
May.....	5½	5½	6½	7	2.00	3.40	2	6	5	5½
June.....	5½	5½	6½	7	1.75	3.00	1½	6	5½	5½
July.....	5½	5½	6½	7			1½	6	5½	6½
August.....	5½	6	6½	7			1½	6	5½	5½
September.....	5½	5½	6½	7	1.50	3.25	1½	5½	5	5½
October.....	5	5½	6	7	2.00	3.50	1½	6	5	5½
November.....	4½	5	6	6½	1.75	3.25	1½	5½	4½	5½
December.....	4½	4½	6	6½	1.50	3.30	1½	5½	4½	5½
Year.....	4½	5½	6	7	1.50	3.75	1½	6½	4½	6½
1910.										
January.....	4½	5½	6	6½	1.75	3.25	1½	6½	3½	5
February.....	4½	4½	6	6½	1.75	3.25	1½	6	3½	5
March.....	4½	4½	6	6½	1.60	3.00	1½	5½	3½	4½
April.....	4	4	6	6	1.55	2.65	1½	5	3½	4½
May.....	4½	4½	6	6½	1.60	2.50	1½	6	3½	4½
June.....	4½	4½	6	6	1.60	2.75	1½	5	3½	4½
July.....	4½	4½	6	6½	1.60	2.65	1½	6	3½	4½
August.....	4½	4½	6	6½	1.60	2.85	1½	5½	3½	5½
September.....	4½	4½	6	6½	1.75	3.10	1½	5½	3½	5
October.....	4½	4½	6	6½	1.75	2.80	1½	5½	3½	5
November.....	4	4½	6	6½	1.75	3.15	1½	4½	3	4½
December.....	4	4½	6	6½	1.75	2.75	1½	4½	3	4
Year.....	4	5½	6	6½	1.55	3.25	1½	6½	3	5½
1911.										
January.....	4½	4½	6	6½	1.75	2.75	1½	4½	3½	3½
February.....	4	4	6	6½	1.75	2.60	1½	4½	3½	3½
March.....	3½	4	6	6½	1.75	2.60	1½	4½	3	3½
April.....	3½	3½	6	6½	1.75	2.75	1½	4½	3	3½
May.....	3½	3½	6	6½	1.75	2.75	1½	4½	2½	4½
June.....	3½	3½	6	6½			1½	4½	3	3½
July.....	3½	3½	6	6½			1½	5	3½	3½
August.....	3½	4	6	6	1.90	3.00	1½	5½	3½	4½
September.....	4	4½	6	6½	1.90	3.00	1½	5½	3½	4½
October.....	4½	4½	6	6½	1.90	3.25	1½	5½	3½	4½
November.....	4½	4½	6	6½	1.90	3.35	1½	5	3½	4½
December.....	4½	4½	6	6½	2.15	3.50	1½	5	3½	4½
Year.....	3½	4½	6	6½	1.75	3.50	1½	5½	2½	4½
1912.										
January.....	4½	4½	6	6½			2½	5½	4½	4½
February.....	4½	5	6	7			2½	5½	4½	5
March.....	4½	5	6	7			2½	5½	4½	5
April.....	4½	5	6	7			2½	5½	4½	5½
May.....	5	5½	6	7			3	5½	4½	5½
June.....	5	5½	6	7			2½	5½	4½	5½
July.....	5	5½	6	7			3	6	4½	5½
August.....	4½	5½	6	7			2½	6	4½	5½
September.....	4½	5	6	7			2½	5½	4½	5½
October.....	4½	5	6	7			2	5	4	4½
November.....	4½	5	6	7			2½	5½	4½	4½
December.....	4½	5	6	7			2½	5½	4½	5½
Year.....	4½	5½	6	7			2	6	4	5½

<sup>1</sup> Louisiana grade, 1899 to 1901.

<sup>2</sup> Per barrel of 162 pounds.

<sup>3</sup> New crop.

TABLE 109.—*International trade in rice, calendar years 1907–1911.*

[Mostly cleaned rice.]

Under rice is included paddy, unhulled, rough, cleaned, polished, broken, and cargo rice, in addition to rice flour and meal. Rice bran is not included. Rough rice or paddy, where specifically reported, has been reduced to terms of cleaned rice at ratio of 162 pounds rough, or unhulled, to 100 pounds cleaned. "Rice, other than whole or cleaned rice," in the returns of United Kingdom is not considered paddy, since the chief sources of supply indicate that it is practically all hulled rice. Cargo rice, a mixture of hulled and unhulled, is included without being reduced to terms of cleaned. Broken rice and rice flour and meal are taken without being reduced to terms of whole cleaned rice. See "General note," p. 564.]

## EXPORTS.

Country.	1907	1908	1909	1910	1911
	<i>Pounds.</i>	<i>Pounds.</i>	<i>Pounds.</i>	<i>Pounds.</i>	<i>Pounds.</i>
Belgium.....	61, 675, 529	84, 551, 890	115, 753, 393	86, 693, 324	100, 314, 577
British India.....	1, 294, 019, 202	3, 736, 178, 635	3, 822, 040, 913	5, 060, 253, 855	5, 783, 915, 236
Dutch East Indies.....	116, 356, 082	126, 512, 420	134, 770, 729	129, 681, 824*	1 133, 178, 832
France.....	98, 088, 802	89, 997, 530	101, 400, 060	106, 500, 516	1 66, 625, 432
French Indo-China.....	3, 033, 535, 939	2, 659, 094, 269	2, 396, 410, 076	2, 603, 117, 237	2 2, 603, 117, 237
Germany.....	338, 459, 742	318, 748, 920	364, 511, 553	375, 623, 211	456, 659, 086
Netherlands.....	315, 261, 440	375, 558, 513	384, 880, 186	495, 090, 914	476, 776, 051
Penang.....	344, 022, 843	330, 399, 949	358, 252, 398	334, 457, 652	1 334, 457, 652
Siam.....	1, 777, 680, 046	2, 037, 902, 085	2, 111, 915, 867	2, 336, 513, 333	1, 365, 349, 405
Singapore.....	677, 447, 819	855, 164, 354	896, 436, 185	808, 021, 088	1 808, 021, 088
Other countries.....	826, 544, 000	825, 966, 000	844, 063, 000	851, 372, 000	1 825, 394, 000
Total.....	8, 883, 091, 444	11, 440, 074, 865	11, 530, 464, 360	13, 187, 324, 954	12, 953, 808, 596

## IMPORTS.

Austria-Hungary.....	190, 223, 250	244, 441, 329	196, 349, 949	198, 824, 252	201, 771, 360
Belgium.....	135, 583, 773	183, 295, 895	184, 379, 515	183, 361, 579	177, 040, 647
Brazil.....	25, 532, 515	14, 920, 283	23, 813, 514	23, 813, 514	23, 813, 514
British India.....	237, 331, 883	319, 184, 659	229, 509, 261	268, 949, 856	344, 818, 143
Ceylon.....	741, 024, 347	684, 746, 518	740, 763, 696	830, 590, 544	820, 668, 266
China.....	1, 702, 025, 200	898, 215, 467	506, 360, 667	1, 229, 518, 533	707, 040, 667
Cuba.....	258, 424, 600	219, 077, 311	240, 968, 236	255, 748, 276	255, 748, 276
Dutch East Indies.....	599, 807, 438	732, 882, 941	864, 187, 549	1, 557, 748, 955	1, 346, 967, 283
Egypt.....	95, 460, 223	102, 471, 561	122, 966, 459	90, 195, 852	84, 841, 328
France.....	345, 984, 903	444, 432, 466	555, 721, 075	565, 265, 849	1 539, 668, 144
Germany.....	714, 152, 417	1, 096, 171, 957	690, 417, 810	977, 335, 766	923, 694, 301
Japan.....	902, 701, 867	647, 138, 353	441, 747, 600	306, 209, 067	573, 188, 667
Mauritius.....	131, 021, 016	131, 261, 913	129, 880, 605	129, 645, 866	151, 761, 344
Netherlands.....	566, 637, 769	673, 524, 095	734, 620, 212	781, 270, 101	738, 228, 176
Penang.....	292, 286, 304	358, 425, 970	411, 705, 534	422, 610, 271	2 422, 610, 271
Perak.....	159, 343, 042	168, 104, 372	169, 358, 668	167, 793, 146	1 167, 793, 146
Philippine Islands.....	262, 399, 906	349, 175, 386	368, 442, 959	435, 025, 385	404, 929, 261
Russia.....	193, 910, 846	249, 485, 657	229, 280, 739	240, 047, 885	258, 371, 629
Selangor.....	144, 936, 640	142, 788, 794	133, 868, 668	137, 780, 822	1 137, 780, 822
Singapore.....	803, 864, 402	964, 541, 386	1, 020, 659, 456	987, 531, 558	2 987, 531, 558
United Kingdom.....	684, 817, 616	793, 066, 176	711, 844, 336	914, 060, 336	682, 871, 840
United States.....	203, 560, 814	217, 345, 410	225, 710, 483	224, 826, 354	1 185, 846, 041
Other countries.....	935, 208, 000	969, 256, 000	1, 090, 193, 000	1, 118, 620, 000	1 1, 152, 471, 000
Total.....	10, 326, 238, 771	10, 603, 954, 479	10, 022, 749, 991	12, 046, 773, 767	11, 289, 455, 684

1 Preliminary.

2 Year preceding.

3 Data for 1909.

## HOPS.

TABLE 110.—*Hop crop of countries named, 1908-1912.*

[Excluding Canada, for which the census of 1901 shows a production in the preceding year of 1,004,216 pounds. Other omitted countries are of very small production.]

Country.	1908	1909	1910	1911	1912 <sup>1</sup>
<b>NORTH AMERICA.</b>					
United States <sup>2</sup> .....	<i>Pounds.</i> 43,900,311	<i>Pounds.</i> 50,697,048	<i>Pounds.</i> 49,634,028	<i>Pounds.</i> 51,672,072	<i>Pounds.</i> <sup>3</sup> 50,000,000
<b>EUROPE.</b>					
<b>Austria-Hungary:</b>					
Austria.....	41,331,000	18,706,000	36,402,000	18,989,000	44,332,000
Hungary.....	1,913,000	1,871,000	1,839,000	<sup>2</sup> 2,200,000	3,300,000
Total Austria-Hungary.....	43,244,000	20,577,000	38,241,000	21,189,000	47,632,000
Belgium.....	8,530,000	3,861,000	7,275,000	5,700,000	7,000,000
France.....	11,369,000	5,029,000	7,126,000	4,950,000	6,820,000
Germany.....	58,069,000	13,356,000	44,998,000	23,430,000	45,334,000
Netherlands <sup>4</sup> .....	158,000	158,000	158,000	158,000	158,000
Russia.....	9,750,000	8,267,000	5,597,000	13,903,000	8,800,000
United Kingdom—England.....	52,725,000	24,022,000	33,900,000	36,739,000	41,825,000
Total.....	183,845,000	75,270,000	137,295,000	106,069,000	157,569,000
<b>AUSTRALASIA.</b>					
<b>Australia:</b>					
Victoria.....	132,000	123,000	98,000	105,000	<sup>5</sup> 105,000
Tasmania.....	1,402,000	1,334,000	1,160,000	1,775,000	<sup>6</sup> 1,775,000
New Zealand <sup>6</sup> .....	941,000	749,000	764,000	709,000	<sup>6</sup> 709,000
Total.....	2,475,000	2,206,000	2,022,000	2,589,000	2,589,000
Grand total.....	230,220,311	128,173,048	188,951,028	160,330,072	210,158,000

<sup>1</sup> Preliminary.

<sup>2</sup> Commercial movement for years beginning July 1, based upon exports, imports, and internal-revenue data for hops used in brewing.

<sup>3</sup> Unofficial estimate.

<sup>4</sup> Estimated average 1900-1903.

<sup>5</sup> Year preceding.

<sup>6</sup> Estimate based on the official figures for area, multiplied by yield as given in census of 1895, 1,088 pounds.

TABLE 111.—*Total production of hops in countries named in Table 110, 1895-1912.*

Year.	Production.	Year.	Production.	Year.	Production.
	<i>Pounds.</i>		<i>Pounds.</i>		<i>Pounds.</i>
1895.....	204,894,000	1901.....	201,902,000	1907.....	215,923,103
1896.....	168,508,800	1902.....	170,063,000	1908.....	230,220,311
1897.....	189,218,340	1903.....	174,457,000	1909.....	128,173,048
1898.....	166,099,860	1904.....	178,802,000	1910.....	188,951,028
1899.....	231,562,800	1905.....	277,260,000	1911.....	160,330,072
1900.....	174,683,000	1906.....	180,998,000	1912 <sup>1</sup> .....	210,158,000

<sup>1</sup> Preliminary.

TABLE 112.—Wholesale price of hops per pound, 1899-1912.

Date.	New York, choice State.		Cincinnati, prime. <sup>1</sup>		Chicago, Pacific coast, good to choice. <sup>2</sup>		Date.	New York, choice State.		Cincinnati, prime.		Chicago, Pacific coast, good to choice.	
	Low.	High.	Low.	High.	Low.	High.		Low.	High.	Low.	High.	Low.	High.
1899.....	Cts. 12	Cts. 18	Cts. 13	Cts. 19	Cts. 7	Cts. 18	1910.	Cts. 21	Cts. 23	Cts. 15½	Cts. 16½	Cts. 16	Cts. 17
1900.....	12½	21	10	18	6½	18	October....	22	23	16	17½	15	17
1901.....	13	20	13½	17 <sup>8</sup> / <sub>10</sub>	12½	19	November..	21	25	17½	18½	15	18
1902.....	14	38	14½	30	12½	31	December..	21	25	17½	18½	15	18
1903.....	20½	37	24	29½	19	31	Year..	21	35	15½	27½	14	26
1904.....	32	41	28	37	28½	37	1911.						
1905.....	13	37	13½	33	10	34	January....	23	29			22	25
1906.....	11	25	12	18½	9	22	February....	28	29			21	24
1907.....	12	23	12		8	18	March.....	28	29			20	22
1908.....	6	16	8		5	11	April.....	28	30			22	24
1909.							May.....	29	31			24	26
January....	12	14	10		10	11	June.....	30	32			26	29
February....	12	15	10		10	11	July.....	31	32			32	34
March.....	13	15	11		10	11½	August....	31	42			40	45
April.....	13	15	11		9	11	September..	41	56			36	42
May.....	13	14	11		10	12	October....	52	56			44	47
June.....	13	17	13		13	15	November..	54	57			48	50
July.....	15	19	14	15	13	15	December..	54	57			48	50
August.....	18	19	16	17	16	18	Year..	23	57			20	50
September..	18	20	20	22	25	28	1912.			choice.			
October....	33	39	28		25	29	January....	53	56	49	49	45	50
November..	34	39	28		24	28	February....	47	55	44½	44½	44	46
December..	33	36	27	28	23	27	March.....	43	55	43½	43½	43	45
Year..	12	39	10	28	9	29	April.....	40	55	43	43	43	45
1910.							May.....	40	52	43	43	42	44
January....	33	35	25½	27½	20	26	June.....	37	45	41	41	40	42
February....	32	35	25½	26½	22	26	July.....	28	38	34	34	28	30
March.....	28	34	24½	25½	22	24	August....	23	30	25½	25½	22	25
April.....	24	29	24	24½	17	19	September..	22	33	23½	23½	21	23
May.....	23	25	20	21	16	18	October....	30	33	22½	22½	22	24
June.....	22	24	16	17	16	18	November..	31	33	22½	22½	21	24
July.....	22	23	16	17½	14	16	December..	30	42	22½	22½	20	23
August.....	21	23	16	17½	14	16	Year..	22	56	22½	49	20	50
September..	21	22	16½		14	16							

<sup>1</sup> Choice 1899-1907.

<sup>2</sup> Common to choice 1899-1903.

<sup>3</sup> Prime to choice.

TABLE 113.—*International trade in hops, calendar years 1907–1911.*

[Lupulin and *hopfenmehl* (hop meal) are not included with hops in the data shown. See "General note," p. 564.]

## EXPORTS.

Country.	1907	1908	1909	1910	1911
	<i>Pounds.</i>	<i>Pounds.</i>	<i>Pounds.</i>	<i>Pounds.</i>	<i>Pounds.</i>
Austria-Hungary.....	17,825,955	15,498,118	17,834,112	18,574,857	11,765,950
Belgium.....	2,166,804	1,403,025	2,508,319	2,726,834	8,958,288
France.....	386,687	152,338	163,802	180,777	<sup>1</sup> 398,812
Germany.....	22,539,830	27,341,670	19,408,417	19,115,646	16,744,378
Netherlands.....	1,561,223	1,771,139	1,442,399	1,189,007	1,153,907
New Zealand.....	286,160	1,770,016	347,984	431,312	205,296
Russia.....	681,990	241,342	2,622,403	725,506	2,224,296
United Kingdom.....	1,168,720	1,059,632	1,750,896	999,824	5,478,816
United States.....	16,090,959	21,423,869	8,955,533	12,748,617	14,104,004
Other countries.....	258,000	98,000	228,000	232,000	<sup>1</sup> 60,000
Total.....	62,966,328	69,159,149	55,261,865	56,924,470	61,093,747

## IMPORTS.

Australia.....	1,020,898	973,814	847,791	1,135,182	906,902
Austria-Hungary.....	773,594	553,355	585,321	289,243	2,180,129
Belgium.....	5,577,856	6,025,291	6,630,010	5,582,601	8,822,752
British India.....	470,736	363,888	300,944	233,744	284,704
British South Africa.....	588,672	543,984	435,344	532,224	541,184
Canada.....	1,223,478	1,205,845	1,245,449	1,072,467	1,271,365
Denmark.....	1,292,998	1,340,948	1,102,520	1,041,894	1,006,841
France.....	4,297,868	4,907,881	5,725,567	5,145,977	<sup>1</sup> 7,443,171
Germany.....	6,666,269	6,154,802	8,016,587	6,990,787	6,099,908
Netherlands.....	3,372,923	3,386,676	2,946,876	2,658,463	2,910,685
Russia.....	1,395,110	1,283,377	1,052,183	1,405,149	1,045,213
Sweden.....	1,488,817	1,165,991	974,140	897,045	842,159
Switzerland.....	1,421,526	1,289,691	874,785	1,283,739	1,255,520
United Kingdom.....	21,902,048	29,922,256	15,030,512	19,267,584	16,921,520
United States.....	7,163,356	7,367,684	6,807,689	5,823,520	5,567,477
Other countries.....	3,466,000	3,809,000	3,761,000	2,966,000	<sup>1</sup> 3,821,000
Total.....	62,122,149	70,294,483	56,336,718	56,325,619	60,920,530

<sup>1</sup> Preliminary.

## BEANS AND PEAS.

TABLE 114.—*Bean area of countries named, 1907–1911.*

Country.	Area.				
	1907	1908	1909	1910	1911
<b>NORTH AMERICA.</b>					
United States.....	<i>Acres.</i> ( <sup>1</sup> )	<i>Acres.</i> ( <sup>1</sup> )	<i>Acres.</i> 784,500	<i>Acres.</i> ( <sup>1</sup> )	<i>Acres.</i> ( <sup>1</sup> )
Canada:					
Prince Edward Island.....	( <sup>1</sup> )	200	200	100	100
Nova Scotia.....	3,100	3,100	2,900	2,800	1,000
New Brunswick.....	( <sup>1</sup> )	2,000	1,700	1,500	300
Quebec.....	12,400	12,000	11,600	10,700	10,600
Ontario.....	47,600	42,800	39,600	37,900	48,700
Total Canada.....		60,100	56,000	53,000	60,700
<b>SOUTH AMERICA.</b>					
Argentina.....	( <sup>1</sup> )	22,300	( <sup>1</sup> )	( <sup>1</sup> )	65,000
Chile.....	( <sup>1</sup> )	83,800	80,900	68,800	72,200
<b>EUROPE.</b>					
Austria <sup>2</sup> .....	766,300	759,700	685,600	625,800	626,000
Hungary proper <sup>2</sup> .....	76,900	75,400	74,500	71,700	( <sup>1</sup> )
Belgium.....	23,400	22,600	22,800	( <sup>1</sup> )	( <sup>1</sup> )
Bulgaria <sup>2</sup> .....	131,800	173,100	142,400	142,500	( <sup>1</sup> )
Denmark <sup>2</sup> .....	23,400	( <sup>1</sup> )	( <sup>1</sup> )	( <sup>1</sup> )	( <sup>1</sup> )
France.....	645,700	508,200	501,300	549,800	578,100
Italy.....	( <sup>1</sup> )	( <sup>1</sup> )	1,404,400	1,504,400	1,510,000
Luxemburg.....	3,900	4,200	4,900	4,300	3,300
Netherlands.....	72,400	68,800	73,200	65,600	63,300
Russia:					
Russia proper.....	125,800	155,700	132,800	150,500	( <sup>1</sup> )
Poland.....	28,800	28,500	29,800	35,600	( <sup>1</sup> )
Northern Caucasia.....	3,600	4,300	3,400	3,400	( <sup>1</sup> )
Total Russia (European).....	158,200	188,500	166,000	189,500	
Servia.....	21,500	( <sup>1</sup> )	23,100	24,400	( <sup>1</sup> )
Spain.....	1,152,800	1,186,400	1,194,200	1,217,500	1,237,500
Sweden.....	11,200	10,800	10,900	10,100	9,600
United Kingdom:					
England.....	295,100	282,600	301,300	256,500	294,100
Wales.....	1,600	1,100	1,300	1,400	1,100
Scotland.....	11,400	9,600	9,200	9,500	9,500
Ireland.....	1,800	1,800	1,600	1,800	1,700
Total United Kingdom.....	309,900	295,100	313,400	269,200	306,400
<b>ASIA.</b>					
Russia (18 Governments).....	26,400	57,500	49,000	38,400	( <sup>1</sup> )
<b>AUSTRALASIA.</b>					
Australia:					
New South Wales <sup>3</sup> .....	100	200	300	400	300
Victoria <sup>3</sup> .....	12,000	13,600	11,200	9,800	11,100
South Australia <sup>3</sup> .....	7,100	7,500	7,100	8,000	10,000
Western Australia <sup>3</sup> .....	900	900	800	700	800
Tasmania <sup>3</sup> .....	10,600	12,600	12,300	15,900	20,600
Total Australia.....	30,700	34,800	31,700	34,800	42,000
New Zealand.....	2,000	1,200	1,300	( <sup>1</sup> )	1,800
Total Australasia.....	32,700	36,000	33,000		43,800

<sup>1</sup> No data.<sup>2</sup> Including other pulse crops.<sup>3</sup> Including peas.



TABLE 115.—*Bean crop of countries named.*

Country.	Area.				
	1907	1908	1909	1910	1911
<b>NORTH AMERICA.</b>					
United States.....	<i>Bushels.</i> (1)	<i>Bushels.</i> (1)	<i>Bushels.</i> 11, 145, 000	<i>Bushels.</i> (1)	<i>Bushels.</i> (1)
Canada:					
Prince Edward Island.....	(1)	4, 000	4, 000	3, 000	(1)
Nova Scotia.....	53, 000	56, 000	82, 000	63, 000	21, 000
New Brunswick.....	(1)	33, 000	79, 000	35, 000	8, 000
Quebec.....	340, 000	257, 000	255, 000	218, 000	182, 000
Ontario.....	815, 000	895, 000	905, 000	859, 000	945, 000
Total Canada.....		1, 245, 000	1, 325, 000	1, 178, 000	1, 156, 000
Total.....			12, 470, 000		
<b>SOUTH AMERICA.</b>					
Argentina.....	(1)	(1)	(1)	(1)	(1)
Chile.....	(1)	1, 343, 000	1, 173, 000	1, 239, 000	1, 360, 000
Total.....					
<b>EUROPE.</b>					
Austria <sup>2</sup> .....	11, 866, 000	10, 363, 000	11, 718, 000	9, 749, 000	8, 932, 000
Hungary proper <sup>2</sup> .....	1, 067, 000	922, 000	1, 056, 000	998, 000	(1)
Belgium.....	889, 000	814, 000	629, 000	(1)	(1)
Bulgaria <sup>2</sup> .....	989, 000	1, 512, 000	798, 000	1, 690, 000	(1)
Denmark <sup>2</sup> .....	390, 000	548, 000	506, 000	557, 000	525, 000
France.....	8, 986, 000	10, 031, 000	9, 791, 000	9, 639, 000	8, 187, 000
Italy.....	(1)	24, 384, 000	24, 391, 000	18, 730, 000	18, 990, 000
Luxemburg.....	109, 000	102, 000	106, 000	90, 000	51, 000
Netherlands.....	2, 224, 000	2, 331, 000	2, 036, 000	1, 804, 000	1, 664, 000
Roumania.....	3, 430, 000	3, 951, 000	2, 722, 000	3, 726, 000	4, 602, 000
Russia:					
Russia proper.....	1, 890, 000	1, 988, 000	1, 884, 000	1, 896, 000	.....
Poland.....	580, 000	493, 000	616, 000	404, 000	.....
Northern Caucasia.....	75, 000	57, 000	32, 000	49, 000	.....
Total Russia (European).....	2, 545, 000	2, 538, 000	2, 532, 000	2, 349, 000	2, 588, 000
Servia.....	1, 097, 000	(1)	1, 483, 000	2, 279, 000	1, 453, 000
Spain.....	9, 957, 000	11, 217, 000	12, 199, 000	13, 454, 000	14, 372, 000
Sweden.....	189, 000	199, 000	185, 000	173, 000	171, 000
United Kingdom:					
England.....	10, 488, 000	8, 726, 000	8, 832, 000	8, 519, 000	7, 572, 000
Wales.....	46, 000	31, 000	37, 000	40, 000	29, 000
Scotland.....	430, 000	365, 000	350, 000	383, 000	323, 000
Ireland.....	85, 000	74, 000	75, 000	77, 000	60, 000
Total United Kingdom.....	11, 049, 000	9, 196, 000	9, 294, 000	9, 019, 000	7, 984, 000
<b>ASIA.</b>					
Russia (18 Governments).....	254, 000	551, 000	542, 000	402, 000	(1)
<b>AFRICA.</b>					
Algeria.....	988, 000	780, 000	1, 154, 000	1, 035, 000	1, 001, 000
Egypt.....	(1)	(1)	(1)	(1)	(1)
<b>AUSTRALASIA.</b>					
Australia:					
New South Wales <sup>3</sup> .....	3, 000	4, 000	11, 000	13, 000	7, 000
Victoria <sup>3</sup> .....	296, 000	221, 000	204, 000	150, 000	230, 000
South Australia <sup>3</sup> .....	145, 000	122, 000	95, 000	134, 000	202, 000
Western Australia <sup>3</sup> .....	10, 000	9, 000	10, 000	9, 000	5, 000
Tasmania <sup>3</sup> .....	223, 000	261, 000	288, 000	384, 000	514, 000
Total Australia.....	677, 000	617, 000	608, 000	690, 000	958, 000
New Zealand.....	76, 000	45, 000	54, 000	(1)	74, 000
Total Australasia.....	753, 000	662, 000	662, 000	.....	1, 032, 000

<sup>1</sup> No data.<sup>2</sup> Including other pulse crops.<sup>3</sup> Including peas.

TABLE 116.—Wholesale price of beans per bushel, 1899—1912.

Date.	Boston.		Chicago.		Detroit.		San Francisco.	
	Pea.		Pea.		Pea.		Small white (per 100 lbs.).	
	Low.	High.	Low.	High.	Low.	High.	Low.	High.
1899.....			\$0.90	\$1.87	\$1.01	\$1.80	\$2.00	\$3.00
1900.....			1.65	2.25	1.55	2.10	2.85	4.50
1901.....	\$2.00	\$2.75	.90	2.80	1.66	2.40	2.00	5.00
1902.....	1.60	2.55	.85	2.49	1.28	1.98	3.30	4.65
1903.....	2.10	2.45	.90	2.40	1.82	2.35	2.40	3.40
1904.....	1.72½	2.20	.90	2.05	1.58	1.98	2.75	3.32½
1905.....	1.75	2.00	1.00	1.85	1.49	1.85	2.75	3.60
1906.....	1.50	1.80	1.10	1.65	1.27	1.61		
1907.....	1.42	2.45	1.10	2.65	1.28	2.25	2.60	3.60
1908.....	2.30	2.75	1.65	2.70	2.00	2.65	3.40	4.75
1909.								
January.....	2.35	2.45	1.75	2.33	2.15	2.30	4.50	4.90
February.....	2.45	2.55	1.80	2.50	2.25	2.40	5.10	5.30
March.....	2.55	2.55	2.20	2.48	2.35	2.40	5.20	5.40
April.....	2.50	2.55	2.25	2.58	2.36	2.50	5.35	5.65
May.....	2.55	2.75	2.35	2.65	2.50	2.55	5.50	6.00
June.....	2.70	2.75	2.50	2.67	2.50	2.55	6.00	7.00
July.....	2.70	2.75	2.12½	2.67	2.20	2.50	6.25	7.00
August.....	2.60	2.70	2.12½	2.20	2.15	2.20	6.75	7.50
September.....	2.35	2.50	2.12½	2.36	2.10	2.20	4.00	4.50
October.....	2.30	2.40	2.00	2.36	2.00	2.10	4.00	4.65
November.....	2.25	2.35	1.96	2.25	2.00	2.10	4.50	5.00
December.....	2.25	2.30	2.03	2.17	2.55	2.55	4.50	5.00
Year.....	2.25	2.75	1.75	2.67	2.00	2.55	4.00	7.50
1910.								
January.....	2.25	2.35	2.10	2.30	2.07	2.20	4.50	4.85
February.....	2.35	2.40	2.17	2.25	2.12	2.15	4.50	4.80
March.....	2.30	2.35	2.10	2.22	2.08	2.15	4.50	4.85
April.....	2.25	2.30	2.00	2.16	2.03	2.08	4.25	4.85
May.....	2.27½	2.40	2.10	2.35	2.05	2.20	4.25	4.60
June.....	2.40	2.45	2.15	2.40	2.22	2.30	4.00	4.50
July.....	2.45	2.45	2.30	2.50	2.22	2.32	3.85	4.25
August.....	2.45	2.60	2.43	2.78	2.32	2.40	3.85	4.10
September.....	2.65	2.70	2.35	2.78	2.15	2.40	3.85	4.10
October.....	2.45	2.65	2.00	2.55	2.02	2.15	3.60	3.90
November.....	2.35	2.40	2.00	2.30	2.00	2.10	3.25	3.80
December.....	2.30	2.35	1.85	2.30	1.92	2.09	3.25	3.50
Year.....	2.25	2.70	1.85	2.78	1.92	2.40	3.25	4.85
1911.								
January.....	2.30	2.35	1.85	2.18	2.00	2.05	3.00	3.60
February.....	2.20	2.30	1.90	2.18	1.90	1.92	3.25	3.50
March.....	2.05	2.20	1.76	2.05	1.88	1.96	3.25	3.50
April.....	2.10	2.15	1.76	2.10	1.95	1.96	3.40	3.50
May.....	2.10	2.25	1.85	2.18	1.94	2.04	3.25	3.50
June.....	2.20	2.25	1.85	2.38	1.87	2.20	3.25	3.55
July.....	2.25	2.40	1.85	2.38	2.18	2.22	3.40	3.50
August.....	2.40	2.50	2.08	2.45	2.13	2.28	3.45	3.75
September.....	2.40	2.45	2.00	2.35	2.05	2.17	3.60	3.90
October.....	2.40	2.65	2.17	2.55	2.15	2.40	3.50	3.85
November.....	2.60	2.65	2.28	2.57	2.23	2.32	3.50	4.20
December.....	2.50	2.65	2.25	2.50	2.15	2.32	4.00	4.15
Year.....	2.05	2.65	1.76	2.57	1.87	2.40	3.00	4.20
1912.								
January.....	2.55	2.70	2.35	2.58	2.32	2.43	4.10	4.15
February.....	2.65	2.70	2.40	2.60	2.35	2.42	4.10	4.15
March.....	2.60	2.65	2.40	2.63	2.32	2.42	4.00	4.15
April.....	2.65	2.70	2.50	2.65	2.40	2.48	4.00	4.20
May.....	2.75	3.05	2.53	2.90	2.50	2.70	4.10	4.50
June.....	3.00	3.05	2.70	2.97½	2.70	2.70	4.40	4.75
July.....	3.00	3.00	2.75	2.92½	2.65	2.70	4.65	4.80
August.....	3.00	3.05	2.75	2.88	2.60	2.70	4.40	4.80
September.....	3.10	3.10	2.75	3.00	2.50	2.70	4.40	4.50
October.....	3.10	3.10	2.85	3.20	2.40	2.60	4.40	4.70
November.....	2.80	3.00	2.45	3.10	2.30	2.40	4.50	4.70
December.....	2.55	2.80	1.90	2.65	2.15	2.30	4.50	4.65
Year.....	2.55	3.10	1.90	3.20	2.15	2.70	4.00	4.80

1 Common to fine.

TABLE 117.—Pea area of countries named, 1907–1911.

Country.	Area.				
	1907	1908	1909	1910	1911
NORTH AMERICA.					
United States.....	<i>Acres.</i> (1)	<i>Acres.</i> (1)	<i>Acres.</i> 1,302,400	<i>Acres.</i> (1)	<i>Acres.</i> (1)
Canada:					
Prince Edward Island.....	(1)	600	600	500	100
Nova Scotia.....	1,600	1,500	1,400	1,300	200
New Brunswick.....	(1)	2,700	2,400	2,300	600
Quebec.....	55,800	51,900	46,400	44,000	33,000
Ontario.....	341,000	354,600	341,300	336,800	252,000
Manitoba.....	1,700	1,600	1,200	1,200	.....
Total Canada.....	.....	412,900	393,300	386,100	285,900
SOUTH AMERICA.					
Chile.....	(1)	11,300	12,000	6,500	5,700
EUROPE.					
Belgium.....	13,700	13,200	12,300	(1)	(1)
France.....	80,500	82,600	79,100	72,400	73,000
Luxemburg.....	2,800	2,400	2,400	2,100	1,900
Netherlands.....	75,500	71,800	74,000	64,600	55,300
Roumania.....	26,800	42,800	39,200	29,200	34,100
Russia:					
Russia proper.....	2,595,400	2,838,200	2,935,300	3,174,800	(1)
Poland.....	409,800	399,300	399,200	396,900	(1)
Northern Caucasia.....	14,100	11,700	9,900	11,300	(1)
Total Russia (European).....	3,019,300	3,249,200	3,344,400	3,583,000	(1)
Servia.....	(1)	(1)	1,300	1,500	1,600
Spain.....	509,600	525,100	550,800	553,200	582,200
Sweden.....	48,100	47,500	45,400	43,100	43,800
United Kingdom:					
England.....	159,400	153,100	168,700	151,800	139,200
Wales.....	800	700	700	700	600
Scotland.....	600	600	600	600	500
Ireland.....	300	300	300	200	300
Total United Kingdom.....	161,100	154,700	170,300	153,300	140,600
ASIA.					
Russia (18 governments).....	79,200	89,000	82,800	76,600	(1)
AFRICA.					
Algeria.....	20,400	21,700	22,700	22,700	22,600
AUSTRALASIA.					
New Zealand.....	11,500	8,400	7,000	(1)	14,700

<sup>1</sup> No data.

TABLE 118.—*Pea production of countries named.*

Country.	Area.				
	1907	1908	1909	1910	1911
NORTH AMERICA.					
United States.....	<i>Bushels.</i> ( <sup>1</sup> )	<i>Bushels.</i> ( <sup>1</sup> )	<i>Bushels.</i> 7, 110, 000	<i>Bushels.</i> ( <sup>1</sup> )	<i>Bushels.</i> ( <sup>1</sup> )
Canada:					
Prince Edward Island.....	( <sup>1</sup> )	14, 000	14, 000	8, 000	2, 000
Nova Scotia.....	35, 000	21, 000	53, 000	35, 000	5, 000
New Brunswick.....	( <sup>1</sup> )	24, 000	63, 000	55, 000	15, 000
Quebec.....	1, 049, 000	675, 000	752, 000	729, 000	526, 000
Ontario.....	7, 597, 000	6, 294, 000	7, 239, 000	5, 692, 000	3, 954, 000
Manitoba.....	28, 000	32, 000	24, 000	19, 000	.....
Total Canada.....		7, 060, 000	8, 145, 000	6, 538, 000	4, 502, 000
SOUTH AMERICA.					
Chile.....	( <sup>1</sup> )	128, 000	119, 000	62, 000	44, 000
EUROPE.					
Belgium.....	472, 000	445, 000	281, 000	( <sup>1</sup> )	( <sup>1</sup> )
France.....	1, 541, 000	1, 488, 000	1, 574, 000	1, 380, 000	1, 137, 000
Luxemburg.....	68, 000	46, 000	49, 000	34, 000	31, 000
Netherlands.....	1, 994, 000	2, 094, 000	1, 452, 000	1, 260, 000	1, 838, 000
Roumania.....	372, 000	354, 000	456, 000	565, 000	598, 000
Russia:					
Russia proper.....	17, 466, 000	17, 639, 000	24, 232, 000	33, 651, 000	.....
Poland.....	5, 810, 000	5, 384, 000	6, 269, 000	4, 691, 000	.....
Northern Caucasia.....	129, 000	53, 000	82, 000	123, 000	.....
Total Russia (European).....	23, 405, 000	23, 076, 000	30, 583, 000	38, 465, 000	33, 043, 000
Servia.....	14, 000	( <sup>1</sup> )	13, 000	35, 000	19, 000
Spain.....	2, 408, 000	4, 933, 000	4, 773, 000	4, 637, 000	4, 684, 000
Sweden.....	763, 000	1, 404, 000	1, 177, 000	1, 295, 000	1, 277, 000
United Kingdom:					
England.....	4, 850, 000	4, 470, 000	4, 506, 000	4, 098, 000	3, 788, 000
Wales.....	18, 000	17, 000	16, 000	16, 000	14, 000
Scotland.....	17, 000	17, 000	17, 000	17, 000	13, 000
Ireland.....	9, 000	8, 000	8, 000	7, 000	9, 000
Total United Kingdom.....	4, 894, 000	4, 512, 000	4, 547, 000	4, 138, 000	3, 824, 000
ASIA.					
Russia (18 Governments).....	721, 000	939, 000	624, 000	740, 000	( <sup>1</sup> )
AFRICA.					
Algeria.....	272, 000	218, 000	312, 000	312, 000	294, 000
AUSTRALASIA.					
New Zealand.....	347, 000	250, 000	309, 000	( <sup>1</sup> )	523, 000

No data.

## SUGAR.

TABLE 119.—*Production of sugar in countries named, 1907-8 to 1911-12.*

[All data are from official sources, except where otherwise stated. Some figures in the table refer to raw and some to refined sugar, according to the kind reported in the original returns.]

Country.	1907-8	1908-9	1909-10	1910-11	1911-12 (preliminary).
<b>CANE SUGAR.</b>					
<b>NORTH AMERICA.</b>					
United States:					
Contiguous—	<i>Long tons.</i>	<i>Long tons.</i>	<i>Long tons.</i>	<i>Long tons.</i>	<i>Long tons.</i>
Louisiana.....	1 340,000	1 355,000	2 290,639	1 306,000	297,000
Texas.....	1 12,000	1 15,000	2 7,856	1 11,000	17,000
Noncontiguous—					
Hawaii <sup>1</sup> .....	465,000	478,000	463,000	503,000	531,000
Porto Rico.....	205,400	247,400	309,600	312,400	331,300
Total United States.....	1,022,400	1,095,400	1,071,095	1,135,400	1,166,300
Central America:					
British Honduras.....	600	600	400	700	700
Costa Rica <sup>1</sup> .....	2,000	3,000	3,000	3,000	3,000
Guatemala <sup>1</sup> .....	7,000	7,000	7,000	7,000	7,000
Nicaragua.....	3 5,000	10,000	4 10,000	3,000	5 3,000
Salvador <sup>1</sup> .....	5,000	6,000	6,000	7,000	7,000
Mexico.....	121,300	140,900	145,600	159,000	152,600
West Indies:					
British—					
Antigua.....	14,800	13,300	9,200	14,100	11,700
Barbados.....	38,000	36,400	18,300	40,400	26,700
Dominica.....	100	100	100	100	100
Jamaica.....	28,500	24,000	18,800	28,300	28,400
Montserrat.....	400	100	100	200	100
St. Christopher-Nevis.....	14,900	11,700	12,300	13,000	13,000
St. Lucia.....	5,000	5,500	5,000	5,300	4,500
St. Vincent.....	200	200	300	300	300
Trinidad and Tobago.....	50,600	48,900	53,000	52,000	47,000
Cuba.....	969,300	1,521,800	1,817,500	1,460,000	1,866,000
Danish <sup>6</sup> .....	12,600	4,400	11,900	11,600	6 11,600
French—					
Guadeloupe <sup>6</sup> .....	35,500	24,800	42,200	42,200	6 42,200
Martinique <sup>6</sup> .....	35,400	37,400	39,300	39,300	5 39,300
Santo Domingo <sup>6</sup> .....	62,200	69,500	91,400	90,600	96,400
Total.....	2,430,800	3,061,000	3,362,495	3,112,500	3,526,900
<b>SOUTH AMERICA.</b>					
Argentina <sup>7</sup> .....	111,600	159,100	125,300	146,200	177,200
Brazil <sup>1</sup> .....	194,000	244,000	249,000	282,000	231,000
Guiana:					
British <sup>8</sup> .....	115,200	108,500	101,000	108,300	99,400
Dutch.....	11,700	11,800	10,800	11,900	6 11,900
Peru <sup>1</sup> .....	133,000	148,000	148,000	162,000	6 162,000
Total.....	565,500	671,400	634,100	710,400	681,500
<b>EUROPE.</b>					
Spain.....	15,800	13,800	21,300	20,000	21,000
<b>ASIA.</b>					
British India <sup>9</sup> .....	2,046,900	1,872,900	2,127,100	2,217,800	2,390,400
Federated Malay States:					
Perak.....	12,200	11,400	10 12,000	10 12,000	10 12,000
Formosa.....	64,500	120,400	202,500	202,500	202,500
Japan.....	49,200	53,100	57,900	64,700	64,700
Java.....	1,191,000	1,222,000	1,222,000	1,230,000	1,413,000
Philippine Islands <sup>11</sup> .....	149,300	110,600	125,700	147,000	183,000
Total.....	3,513,100	3,390,400	3,747,200	3,874,000	4,265,600

<sup>1</sup> Unofficial estimate.<sup>2</sup> Census. Data for Louisiana exclude 2 establishments not classed as sugar factories; data for Texas include these 2 establishments, also small quantities of sugar made in States other than Texas and Louisiana.<sup>3</sup> Data for 1906-7.<sup>4</sup> Data for 1908-9.<sup>6</sup> Year preceding.<sup>6</sup> Exports.<sup>7</sup> Sugar on which internal-revenue tax was paid.<sup>8</sup> Exports for year ending Mar. 31.<sup>9</sup> The figures represent the production of about 97 per cent of the area under sugar cane and 90 per cent of the area under all sugar crops.<sup>10</sup> Average production 1907-8 and 1908-9.<sup>11</sup> Exports for year ending June 30.

TABLE 119.—Production of sugar in countries named, 1907-8 to 1911-12—Continued.

Country.	1907-8	1908-9	1909-10	1910-11	1911-12 (preliminary).
AFRICA.					
Egypt.....	26,000	36,000	56,000	56,000	56,000
Mauritius <sup>1</sup> .....	161,500	192,800	248,000	219,300	166,900
Natal.....	32,000	77,500	77,500	80,700	90,500
Portuguese East Africa.....	3,000	13,000	17,000	15,000	27,000
Reunion <sup>2</sup> .....	46,500	38,800	33,000	43,000	40,000
Total.....	269,000	358,100	431,500	414,000	380,400
OCEANIA.					
Australia:					
Queensland.....	185,100	150,400	132,800	210,800	173,300
New South Wales.....	29,200	15,300	14,700	18,800	17,000
Fiji.....	68,300	66,100	68,900	68,800	72,600
Total.....	282,600	231,800	216,400	298,400	262,900
Total cane sugar.....	7,076,800	7,726,500	8,412,995	8,429,300	9,138,300
BEET SUGAR.					
NORTH AMERICA.					
United States: Contiguous.....	414,000	380,000	447,930	456,000	535,000
Canada: Ontario <sup>3</sup> .....	9,400	6,940	6,940	9,200	9,900
Total.....	423,400	389,400	457,330	465,200	544,900
EUROPE.					
Austria-Hungary <sup>7</sup> .....	1,389,300	1,365,500	1,225,900	1,496,000	1,124,900
Belgium.....	223,400	243,700	235,000	267,000	231,000
Bulgaria <sup>1</sup> .....	8,000	7,000	6,000	6,000	6,000
Denmark.....	51,800	65,300	61,800	98,900	51,900
France <sup>8</sup> .....	637,000	701,400	711,500	630,000	448,000
Germany.....	2,104,900	2,046,400	2,005,200	2,548,900	1,474,100
Greece <sup>1</sup> .....	400	1,000	2,100	2,100	2,100
Italy <sup>1</sup> .....	134,000	163,000	109,000	170,000	165,000
Netherlands.....	156,000	194,000	178,000	196,000	270,000
Roumania <sup>1</sup> .....	23,000	25,000	27,000	27,000	27,000
Russia <sup>9</sup> .....	1,232,800	1,109,100	1,002,400	1,882,700	1,808,800
Servia <sup>10</sup> .....	7,300	7,300	7,300	7,300	7,300
Spain.....	93,000	107,000	85,000	70,000	85,000
Sweden.....	110,000	134,000	125,000	171,200	121,000
Switzerland <sup>1</sup> .....	3,700	4,000	3,600	3,600	3,600
Total.....	6,174,600	6,173,200	5,784,300	7,575,600	5,824,600
Total beet sugar.....	6,598,000	6,562,600	6,241,630	8,040,800	6,369,500
Total beet and cane sugar.....	13,674,800	14,289,100	14,654,625	16,470,100	15,507,800

<sup>1</sup> Unofficial estimate.

<sup>2</sup> Data for 1908-9.

<sup>3</sup> Exports for calendar year in which crop year ends.

<sup>4</sup> Census returns.

<sup>5</sup> In addition to Ontario, Alberta produced 2,230 long tons in 1907-8.

<sup>6</sup> Data for 1907-8.

<sup>7</sup> Estimate as returned by Central Union for Beet Sugar Industry.

<sup>8</sup> In terms of refined sugar. Total production of sugar and molasses in terms of refined sugar: 1907-8, 646,452; 1908-9, 711,654; 1909-10, 722,303; 1910-11, 640,208; 1911-12, 458,023 long tons.

<sup>9</sup> Sugar made from beets "entering factories."

<sup>10</sup> Average production as unofficially estimated.

TABLE 120.—Total production of sugar in countries named in Table 119, 1895-6 to 1911-12.

Year.	Production.			Year.	Production.		
	Cane. <sup>1</sup>	Beet.	Total.		Cane. <sup>1</sup>	Beet.	Total.
1895-96.....	2,909,577	4,314,649	7,224,226	1904-5.....	6,841,207	4,952,907	11,774,114
1896-97.....	2,830,857	4,954,032	7,784,889	1905-6.....	6,741,833	7,223,155	13,964,988
1897-98.....	2,862,255	4,872,172	7,734,427	1906-7.....	7,468,900	6,774,400	14,243,300
1898-99.....	2,995,438	5,014,472	8,009,910	1907-8.....	7,076,800	6,598,000	13,674,800
1899-1900.....	3,026,113	5,590,992	8,617,105	1908-9.....	7,726,500	6,562,600	14,289,100
1900-1901.....	3,646,059	6,066,939	9,712,998	1909-10.....	8,412,995	6,241,630	14,654,625
1901-2.....	6,087,218	6,913,604	13,008,822	1910-11.....	8,429,300	8,040,800	16,470,100
1902-3.....	6,055,725	5,762,735	11,818,460	1911-12 <sup>2</sup> .....	9,138,300	6,369,500	15,507,800
1903-4.....	6,168,791	6,102,868	12,271,659				

<sup>1</sup> Prior to 1901-2, these figures include exports instead of production for British India.

<sup>2</sup> Preliminary.

TABLE 121.—*Production of sugar in the United States and its possessions, 1839-40 to 1912-13.*

[Census data, as far as available, are given in *italics*. Census of 1840 did not separate cane and maple sugar; statistics for "Other Southern States" represent production of all sugar in South Carolina, Georgia, Florida, Tennessee, Alabama, and Mississippi. Censuses of 1850 and 1860 give returns in "hogsheads of 1,000 pounds" and Censuses of 1870 and 1880 in "hogsheads"; these returns were converted into pounds, in Census Abstract of 1890 at rate of 1,200 pounds to the hogshead and in Census of 1900 at rate of 1,000 pounds. Beet-sugar production for 1897-98, for 1901-2 and later years from United States Department of Agriculture reports; for other years from Willett & Gray. Production of cane sugar in Louisiana 1906-7 to 1910-11; and in Texas beginning 1903-4, from Willett & Gray; earlier statistics for Louisiana and other Southern States from Bouchereau, in part taken directly from his reports and in part from the Statistical Abstract of the United States; Louisiana, beginning with 1911-12, United States Department of Agriculture; Porto Rican production of cane sugar for 1854-55 to 1884-85 from Rueb & Co.; 1885-86 to 1890-1900 from Willett & Gray; 1900-1901 to 1906-7, shipments from Porto Rico to the United States; 1907-8 and subsequently, crops, from reports of Treasury Department of Porto Rico. Statistics for Hawaii, 1874-75 to 1880-81, represent exports from Bureau of Statistics Bul. 30; for 1881-82 to 1884-85 from Rueb & Co.; 1885-86 to 1900-1901 from Willett & Gray; 1901-2 and subsequently, Hawaiian Sugar Planters' Association. Statistics for Philippine Islands for 1854-55 to 1857-58, 1859-60 to 1866-67, 1872-73 to 1894-95 represent exports as officially returned, taken from the census of the Philippine Islands, 1903; for 1858-59, 1867-68 to 1871-72 from Foreign Markets Bul. 14, representing commercial estimates of exports; 1894-95 to 1898-99, exports from Willett & Gray; subsequent to 1898-99 (except the census crop of 1902), exports from official sources.]

Year.	Beet sugar.	Cane sugar.					Total.
		Louisiana.	Other Southern States.	Porto Rico.	Hawaii.	Philippine Islands.	
1839-40 (Census) . . . . .	<i>Long tons.</i>	<i>Long tons.</i> 53, 548	<i>Long tons.</i> 408	<i>Long tons.</i>	<i>Long tons.</i>	<i>Long tons.</i>	<i>Long tons.</i>
1849-50 (Census) . . . . .		<i>Hogsheads.</i> 226, 001	<i>Hogsheads.</i> 21, 676				
1854-55 . . . . .		<i>Long tons.</i> 171, 976	<i>Long tons.</i> 13, 169	58, 377		35, 008	278, 530
1855-56 . . . . .		113, 647	9, 821	82, 000		47, 397	252, 865
1856-57 . . . . .		36, 327	2, 673	85, 000		36, 066	160, 066
1857-58 . . . . .		137, 351	6, 385	69, 444		26, 858	240, 038
1858-59 . . . . .		185, 177	8, 169	58, 000		50, 095	301, 441
1859-60 . . . . .		113, 891	5, 149	57, 000		49, 013	225, 053
1859-60 (Census) . . . . .		<i>Hogsheads.</i> 221, 726	<i>Hogsheads.</i> 9, 256				
1860-61 . . . . .		<i>Long tons.</i> 118, 332	<i>Long tons.</i> 4, 313	67, 000		45, 316	234, 961
1861-62 . . . . .		235, 858	5, 138	68, 000		60, 957	369, 953
1862-63 . . . . .		43, 232	2, 768	63, 000		51, 240	160, 240
1863-64 . . . . .		37, 723	250	61, 590		44, 325	144, 288
1864-65 . . . . .		4, 821	179	63, 375		46, 092	114, 867
1865-66 . . . . .		8, 884	348	64, 417		40, 636	114, 685
1866-67 . . . . .		19, 152	3, 348	68, 229		55, 195	146, 324
1867-68 . . . . .		18, 482	4, 518	73, 935		74, 081	171, 416
1868-69 . . . . .		42, 434	2, 567	81, 500		68, 818	195, 719
1869-70 . . . . .		44, 399	2, 402	102, 110		78, 214	227, 525
1869-70 (Census) . . . . .		<i>Hogsheads.</i> 80, 706	<i>Hogsheads.</i> 6, 337				
1870-71 . . . . .		<i>Long tons.</i> 75, 392	<i>Long tons.</i> 4, 208	103, 304		87, 465	270, 769
1871-72 . . . . .		65, 583	4, 217	89, 559		95, 526	255, 285
1872-73 . . . . .	500	55, 958	4, 235	87, 639		83, 865	232, 197
1873-74 . . . . .	700	46, 090	2, 410	71, 755		99, 770	220, 725
1874-75 . . . . .		60, 047	3, 454	72, 128	11, 197	126, 089	273, 015
1875-76 . . . . .	2 100	72, 954	4, 046	70, 016	11, 639	128, 485	287, 240
1876-77 . . . . .		85, 122	3, 879	62, 340	11, 418	121, 052	283, 911
1877-78 . . . . .		65, 671	5, 330	84, 347	17, 157	120, 096	292, 701
1878-79 . . . . .	200	106, 910	5, 090	76, 411	21, 884	129, 777	340, 272
1879-80 . . . . .	1, 200	88, 822	3, 980	57, 057	28, 386	178, 329	357, 774
1879-80 (Census) . . . . .		<i>Hogsheads.</i> 171, 706	<i>Hogsheads.</i> 7, 166				
1880-81 . . . . .	500	<i>Long tons.</i> 121, 867	<i>Long tons.</i> 5, 500	61, 715	41, 870	205, 508	436, 960
1881-82 . . . . .		71, 373	5, 000	80, 066	50, 972	148, 047	355, 958
1882-83 . . . . .	2 500	135, 297	7, 000	77, 632	51, 705	193, 726	465, 860
1883-84 . . . . .	535	128, 443	6, 800	98, 665	63, 948	120, 199	418, 590
1884-85 . . . . .	953	94, 376	6, 500	70, 000	76, 496	200, 997	449, 322
1885-86 . . . . .	600	127, 958	7, 200	64, 000	96, 500	182, 019	478, 277
1886-87 . . . . .	800	80, 859	4, 535	86, 000	95, 000	169, 040	436, 234
1887-88 . . . . .	255	157, 971	9, 843	60, 000	100, 000	158, 445	486, 514
1888-89 . . . . .	1, 861	144, 878	9, 031	62, 000	120, 000	224, 861	562, 631
1889-90 . . . . .	2, 203	128, 344	8, 159	55, 000	120, 000	142, 554	456, 260
1889-90 (Census) . . . . .		<i>Long tons.</i> 130, 413	<i>Long tons.</i> 4, 089				

<sup>1</sup> Mean annual production; quantity varied from year to year between 300 and 500 tons.

<sup>2</sup> Production uncertain; not exceeding quantity stated.

TABLE 121.—Production of sugar in the United States and its possessions, 1839-40 to 1912-13—Continued.

Year.	Beet sugar.	Cane sugar.					Total.
		Louisiana.	Other Southern States.	Porto Rico.	Hawaii.	Philippine Islands.	
1890-91.....	<i>Long tons.</i> 3,459	<i>Long tons.</i> 215,844	<i>Long tons.</i> 6,107	<i>Long tons.</i> 50,000	<i>Long tons.</i> 125,000	<i>Long tons.</i> 136,035	<i>Long tons.</i> 536,445
1891-92.....	5,356	160,937	4,500	70,000	115,598	248,806	605,197
1892-93.....	12,018	217,525	5,000	50,000	140,000	257,392	681,935
1893-94.....	19,950	265,536	6,854	60,000	136,689	207,319	696,648
1894-95.....	20,092	317,354	8,288	52,500	131,698	336,076	865,988
1895-96.....	29,220	237,721	4,973	50,000	201,632	230,000	753,546
1896-97.....	37,536.	282,009	5,570	58,000	224,218	202,000	809,333
1897-98.....	40,398	310,447	5,737	54,000	204,833	178,000	793,415
1898-99.....	32,471	245,512	3,442	53,826	252,507	93,000	680,753
1898-99 (Census).....		<i>248,658</i>	<i>1 5,236</i>				
1899-1900.....	72,944	147,164	2,027	35,000	258,521	73,193	588,849
1899-1900 (Census).....	<i>72,972</i>	<i>148,486</i>	<i>1,510</i>		<i>242,008</i>		
1900-1901.....	76,859	275,579	2,891	72,800	321,461	55,244	804,834
1901-2.....	164,827	321,676	3,614	92,100	317,509	66,974	966,700
1902-3.....	195,005	323,227	3,722	89,800	391,062	109,918	1,118,734
1902 (Census).....						<i>177,571</i>	
1903-4.....	214,825	228,477	1 19,800	123,300	328,003	73,978	988,383
1904-5.....	216,173	355,531	1 15,000	134,900	380,576	111,849	1,214,029
1904-5 (Census).....	<i>226,715</i>						
1905-6.....	279,393	336,752	1 12,000	191,500	383,225	123,790	1,326,660
1906-7.....	431,796	230,000	1 13,000	184,700	392,871	118,395	1,370,762
1907-8.....	413,954	340,000	1 12,000	205,441	465,288	149,323	1,586,006
1908-9.....	380,254	355,000	1 15,000	247,404	477,817	110,604	1,586,079
1909 (Census).....	447,930	290,639	1 7,856				
1909-10.....	457,562	325,000	1 10,000	309,630	462,613	125,699	1,690,504
1910-11.....	455,511	306,000	1 11,000	312,357	506,090	147,016	1,737,974
1911-12.....	535,268	297,000	1 7,143	331,318	531,480	183,077	1,885,236
1912-13 4.....	618,354		1 8,036				

<sup>1</sup> Texas.

<sup>2</sup> Excluding production of two establishments not classed as sugar factories.

<sup>3</sup> Including production of two establishments in Louisiana not classed as sugar factories.

<sup>4</sup> Preliminary.

TABLE 122.—Sugar-beet and beet-sugar production, United States, 1901 to 1912.

Year of beet crop, and State.	Number of factories.	Average length of campaign.	Sugar made.	Sugar beets used.			Analysis of beets.		Recovery of sucrose. <sup>3</sup>		Loss. <sup>4</sup>	
				Area harvested.	Average yield per acre.	Quantity worked.	Average price per ton.	Percentage of sucrose. <sup>1</sup>	Purity coefficient. <sup>2</sup>	Percentage of weight of beets.		Percentage of total sucrose in beets.
1901.....	36	88	184,606	175,083	9.63	1,685,689	4.50	14.8	82.20	10.95	73.99	3.85
1902.....	41	94	218,406	216,400	8.76	1,895,812	5.03	14.6	83.30	11.52	78.90	3.08
1903.....	49	75	240,604	242,576	8.56	2,076,494	4.97	15.1	83.00	11.59	76.75	3.51
1904.....	48	78	242,113	197,784	10.47	2,071,539	4.95	15.2	83.10	11.69	76.41	3.61
1905.....	52	77	312,921	307,364	8.67	2,665,913	5.00	15.3	83.00	11.74	76.73	3.56
1906.....	63	105	483,612	376,074	11.26	4,236,112	5.10	14.9	82.20	11.42	76.64	3.48
1907.....	63	89	463,628	370,984	10.16	3,767,871	5.20	15.8	83.60	12.30	77.85	3.50
1908.....	62	74	425,884	364,913	9.36	3,414,891	5.35	15.74	83.50	12.47	79.22	3.27
1909.....	65	83	512,469	420,262	9.71	4,081,382	5.50	16.3	84.10	12.56	78.01	3.54
1910.....	61	83	510,172	398,029	10.17	4,047,292	5.50	16.35	84.35	12.61	77.13	3.74
1911 6.....	66	94	599,500	473,877	10.68	5,062,333	5.50	15.89	84.49	11.84	74.51	4.05
1912.....	73	86	692,556	555,300	9.41	5,224,377	5.82	16.31	84.49	13.26	81.12	3.05

See footnotes page 652.



TABLE 122.—*Sugar-beet and beet-sugar production, United States, 1901 to 1912—Con.*

Year of beet crop, and State.	Number of factories.		Average length of campaign.	Sugar made.	Sugar beets used.				Analysis of beets.		Recovery of sucrose. <sup>3</sup>		Loss. <sup>4</sup>
	Area harvested.	Average yield per acre.			Quantity worked.	Average price per ton.	Percentage of sucrose. <sup>1</sup>	Purity coefficient. <sup>2</sup>	Percentage of weight of beets.	Percentage of total sucrose in beets.			
	Number.	Days.	Short tons.	Acres.	Short tons.	Short tons.	Dolls.	Per cent.	Per cent.	Per cent.	Per cent.	Per cent.	
1911. <sup>6</sup>													
California.....	10	98.5	161,300	99,545	10.42	1,037,283	5.54	18.95	.....	15.55	84.06	3.40	
Colorado.....	14	63.3	124,800	86,437	11.07	957,142	5.55	15.44	.....	13.04	84.46	2.40	
Idaho.....	3	91	26,730	17,052	12.11	206,367	5.02	16.65	.....	12.95	77.78	3.70	
Michigan.....	17	122	125,500	145,837	9.90	1,443,856	5.74	14.59	.....	8.69	59.56	5.90	
Utah.....	6	96	57,280	33,950	13.03	442,310	4.81	15.98	.....	12.95	81.04	3.03	
Wisconsin.....	4	106	23,640	23,241	11.02	256,124	5.51	14.23	.....	9.23	64.86	5.00	
Other States.....	12	83	80,250	67,815	10.61	719,251	5.48	15.16	.....	11.16	73.61	4.00	
United States.....	66	94	599,500	473,877	10.68	5,062,333	5.50	15.89	.....	11.84	74.51	4.05	
1912.													
California.....	11	90	158,904	111,416	9.01	1,004,328	6.46	18.79	83.99	15.82	84.19	2.97	
Colorado.....	17	91	216,010	144,999	11.32	1,641,861	5.96	16.19	84.81	13.16	81.28	3.03	
Michigan.....	16	74	95,049	124,241	6.75	838,784	5.69	14.72	83.75	11.33	76.97	3.39	
Idaho and Utah.....	10	87	84,332	56,952	10.81	615,749	4.97	16.65	86.83	13.70	82.28	2.95	
Ohio, Indiana, Illinois, and Wisconsin.....	11	87	57,921	53,986	9.90	534,438	5.60	14.43	82.30	10.84	75.12	3.59	
Other States.....	8	88	80,340	63,706	9.25	589,217	5.81	16.61	84.13	13.64	80.49	2.97	
United States.....	73	86	692,556	555,200	9.41	5,224,377	5.82	16.31	84.49	13.26	81.12	3.05	

<sup>1</sup> Based upon weight of beets.

<sup>2</sup> Percentage of sucrose (pure sugar) in the total soluble solids of the beets.

<sup>3</sup> Percentage of sucrose actually extracted by factories.

<sup>4</sup> Percentage of sucrose (based upon weight of beets) remaining in molasses and pulp.

<sup>5</sup> S. Doc. 22, 61st Cong., 1st sess.

<sup>6</sup> Compiled by the Bureau of Plant Industry, Department of Agriculture.

<sup>7</sup> Including estimates of one factory, based upon acreage of beets.

TABLE 123.—*Wholesale price of sugar per pound, by months, on New York market, 1908-1912.*

Date.	Raw.				Refined.									
	Muscovado, 89° polarization.		Centrifugal, 96° polarization.		Cut loaf.		Powdered.		Granulated, fine or standard.		Soft sugar No. 1.		Soft sugar No. 15.	
	Low.	High.	Low.	High.	Low.	High.	Low.	High.	Low.	High.	Low.	High.	Low.	High.
1908.	Cents.	Cents.	Cents.	Cents.	Cents.	Cents.	Cents.	Cents.	Cents.	Cents.	Cents.	Cents.	Cents.	Cents.
January.....	3.27	3.45	3.77	3.95	5.60	5.70	4.90	5.00	4.80	4.90	4.55	4.65	3.95	4.05
February.....	3.17	3.38	3.67	3.88	5.60	5.70	4.90	5.00	4.80	4.90	4.55	4.65	3.95	4.05
March.....	3.36	3.86	3.86	4.36	5.70	6.20	5.00	5.50	4.90	5.40	4.65	5.15	4.05	4.55
April.....	3.86	3.98	4.36	4.48	6.20	6.30	5.50	5.60	5.40	5.50	5.15	5.25	4.55	4.65
May.....	3.74	3.92	4.24	4.42	6.20	6.30	5.50	5.60	5.40	5.50	5.15	5.25	4.55	4.65
June.....	3.75	3.92	4.25	4.42	6.20	6.30	5.50	5.60	5.40	5.50	5.15	5.25	4.55	4.65
July.....	3.67	3.92	4.17	4.42	6.10	6.20	5.40	5.50	5.30	5.40	5.15	5.15	4.55	4.55
August.....	3.40	3.75	3.90	4.25	5.80	6.10	5.10	5.40	5.00	5.30	4.75	5.05	4.15	4.45
September.....	3.40	3.48	3.90	3.98	5.80	6.00	5.10	5.30	5.00	5.20	4.75	4.95	4.15	4.35
October.....	3.46	3.59	3.96	4.09	5.80	6.00	5.10	5.30	5.00	5.20	4.75	4.95	4.15	4.35
November.....	3.42	3.48	3.92	3.98	5.60	5.90	4.90	5.20	4.80	5.10	4.55	4.85	3.95	4.25
December.....	3.17	3.42	3.67	3.92	5.45	5.70	4.75	5.00	4.65	4.90	4.40	4.65	3.80	4.05
Year.....	3.17	3.92	3.67	4.48	5.45	6.30	4.75	5.60	4.65	5.50	4.40	5.25	3.80	4.65

TABLE 123.—Wholesale price of sugar per pound, by months, on New York market, 1908-1912—Continued.

Date.	Raw.				Refined.									
	Muscovado, 89° polariza- tion.		Centrifugal, 96° polariza- tion.		Cut loaf.		Powdered.		Granulated, fine or standard.		Soft sugar No. 1.		Soft sugar No. 13.	
	Low.	High.	Low.	High.	Low.	High.	Low.	High.	Low.	High.	Low.	High.	Low.	High.
1909.	<i>Cents.</i>	<i>Cents.</i>	<i>Cents.</i>	<i>Cents.</i>	<i>Cents.</i>	<i>Cents.</i>	<i>Cents.</i>	<i>Cents.</i>	<i>Cents.</i>	<i>Cents.</i>	<i>Cents.</i>	<i>Cents.</i>	<i>Cents.</i>	<i>Cents.</i>
January.....	3.17	3.25	3.67	3.75	5.45	5.45	4.75	4.75	4.65	4.65	4.40	4.40	3.80	3.85
February.....	3.11	3.24	3.61	3.74	5.35	5.45	4.65	4.75	4.55	4.65	4.36	4.40	3.70	3.85
March.....	3.24	3.50	3.74	4.00	5.45	5.75	4.75	5.05	4.65	4.95	4.40	4.40	3.80	4.10
April.....	3.36	3.55	3.86	4.05	5.75	5.85	5.05	5.15	4.95	5.05	4.70	4.80	4.10	4.20
May.....	3.36	3.45	3.86	3.95	5.75	5.85	5.05	5.15	4.95	5.05	4.70	4.80	4.10	4.25
June.....	3.36	3.42	3.86	3.92	5.75	5.75	5.05	5.05	4.95	4.95	4.60	4.70	4.00	4.10
July.....	3.42	3.52	3.92	4.02	5.65	5.75	4.95	5.05	4.85	4.95	4.60	4.70	4.00	4.10
August.....	3.52	3.63	4.02	4.11	5.75	5.85	5.05	5.15	4.95	5.05	4.70	4.80	4.10	4.20
September.....	3.65	3.74	4.11	4.24	5.95	6.10	5.15	5.25	5.05	5.15	4.95	4.95	4.30	4.45
October.....	3.70	3.90	4.20	4.40	5.95	6.05	5.25	5.25	5.15	5.15	4.95	4.95	4.30	4.30
November.....	3.80	3.95	4.30	4.45	5.95	6.05	5.25	5.35	5.15	5.25	4.95	5.00	4.30	4.40
December.....	3.52	3.83	4.30	4.33	5.75	6.05	5.05	5.35	4.95	5.25	4.70	5.00	4.10	4.40
Year.....	3.11	3.95	3.61	4.45	5.35	6.10	4.65	5.40	4.55	5.30	4.30	5.05	3.70	4.45
1910.														
January.....	3.52	3.68	4.02	4.18	5.75	5.95	5.05	5.25	4.95	5.15	4.70	4.90	4.10	4.30
February.....	3.58	3.86	4.08	4.36	5.95	6.05	5.25	5.35	5.15	5.25	4.90	5.00	4.30	4.40
March.....	3.86	3.92	4.36	4.42	6.05	6.05	5.35	5.35	5.25	5.25	5.00	5.00	4.40	4.40
April.....	3.74	3.86	4.24	4.36	5.95	6.05	5.25	5.35	5.15	5.25	4.90	5.00	4.30	4.40
May.....	3.74	3.83	4.24	4.33	5.95	6.05	5.25	5.35	5.15	5.25	4.90	5.00	4.30	4.40
June.....	3.67	3.80	4.17	4.30	5.95	6.05	5.25	5.35	5.15	5.25	4.90	5.00	4.30	4.40
July.....	3.80	3.86	4.30	4.36	5.95	5.95	5.25	5.25	5.15	5.15	4.90	5.00	4.30	4.30
August.....	3.80	3.98	4.30	4.48	5.95	6.05	5.25	5.35	5.15	5.25	4.90	5.10	4.30	4.50
September.....	3.55	3.92	4.05	4.42	5.85	6.05	5.15	5.35	5.05	5.25	4.80	5.10	4.20	4.50
October.....	3.30	3.50	3.80	4.00	5.45	5.85	4.75	5.15	4.65	5.05	4.40	4.80	3.80	4.20
November.....	3.30	3.43	3.80	3.93	5.40	5.45	4.70	4.75	4.60	4.65	4.35	4.40	3.75	3.80
December.....	3.43	3.55	3.93	4.05	5.40	5.70	4.70	5.00	4.60	4.90	4.35	4.65	3.75	4.05
Year.....	3.30	3.92	3.80	4.48	5.40	6.05	4.70	5.35	4.60	5.25	4.35	5.10	3.75	4.50
1911.														
January.....	2.92	3.36	3.42	3.86	5.50	5.60	4.80	4.90	4.70	4.80	4.55	4.55	3.95	3.95
February.....	2.95	3.30	3.45	3.80	5.40	5.50	4.70	4.80	4.60	4.70	4.45	4.55	3.85	3.95
March.....	3.17	3.42	3.67	3.92	5.50	5.60	4.80	4.90	4.70	4.80	4.55	4.65	3.95	4.05
April.....	3.36	3.42	3.86	3.92	5.60	5.70	4.95	5.00	4.80	4.90	4.65	4.75	4.05	4.15
May.....	3.30	3.36	3.80	3.86	5.70	5.70	5.00	5.00	4.90	4.90	4.75	4.75	4.15	4.15
June.....	3.36	3.80	3.83	3.98	5.70	5.80	5.00	5.10	4.90	5.00	4.75	4.85	4.15	4.25
July.....	3.48	4.20	3.98	4.70	5.80	6.45	5.10	5.75	5.00	5.65	4.85	5.50	4.25	4.90
August.....	4.11	4.86	4.61	5.36	6.45	6.95	5.75	6.25	5.65	6.20	5.50	6.00	4.90	5.40
September.....	4.75	5.46	5.25	5.96	7.05	7.55	6.35	6.85	6.25	6.80	6.15	6.60	5.50	6.00
October.....	5.24	5.46	5.74	5.96	7.40	7.55	6.70	6.85	6.65	6.80	6.45	6.60	6.00	6.00
November.....	4.56	5.24	5.06	5.74	6.90	7.40	6.20	6.70	6.15	6.65	5.95	6.45	5.35	5.85
December.....	4.11	4.56	4.61	5.06	6.65	6.80	5.85	6.10	5.80	6.05	5.60	5.85	4.90	5.25
Year.....	2.92	5.46	3.42	5.96	5.40	7.55	4.70	6.85	4.60	6.80	4.45	6.60	3.85	6.00
1912.														
January.....	3.89	4.15	4.39	4.65	6.20	6.65	5.50	5.85	5.40	5.80	5.25	5.60	4.65	5.00
February.....	3.89	4.30	4.39	4.80	6.10	6.60	5.50	5.90	5.40	5.85	5.25	5.65	4.65	5.05
March.....	3.86	4.17	4.36	4.67	6.30	6.60	5.60	5.90	5.50	5.85	5.35	5.65	4.75	5.05
April.....	3.48	3.86	3.98	4.36	5.90	6.30	5.20	5.60	5.10	5.55	4.95	5.35	4.25	4.75
May.....	3.36	3.55	3.86	4.05	5.90	6.00	5.20	5.30	5.10	5.25	4.95	5.05	4.25	4.45
June.....	3.33	3.48	3.83	3.98	5.80	6.00	5.10	5.30	5.00	5.25	4.85	5.05	4.25	4.45
July.....	3.27	3.55	3.77	4.05	5.80	5.90	5.10	5.20	5.00	5.15	4.85	4.95	4.25	4.35
August.....	3.48	3.74	3.98	4.24	5.80	5.90	5.10	5.20	5.00	5.15	4.85	4.95	4.25	4.35
September.....	3.67	3.86	4.17	4.36	5.90	5.90	5.20	5.20	5.10	5.15	4.85	4.85	4.25	4.25
October.....	3.55	3.67	4.05	4.17	5.70	5.90	5.00	5.20	4.90	5.15	4.65	4.85	4.05	4.25
November.....	3.55	3.55	4.05	4.05	5.70	5.70	5.00	5.00	4.95	4.95	4.65	4.65	4.05	4.05
December.....	3.23	3.55	3.73	4.05	5.70	5.70	5.00	5.00	4.95	4.95	4.65	4.65	4.05	4.05
Year.....	3.23	4.30	3.73	4.80	5.70	6.65	5.00	5.90	4.90	5.85	4.65	5.65	4.05	5.05

TABLE 124.—*International trade in sugar, calendar years, 1907–1911.*

The following kinds and grades have been included under the head of sugar: Brown, white, candied, caramel, *chancaca* (Peru), crystal cube, maple, muscavado, *panela*. The following have been excluded: "Candy" (meaning confectionery), confectionery, glucose, grape sugar, jaggery, molasses, and sirup. See "General note," p. 564.]

## EXPORTS.

Country.	1907	1908	1909	1910	1911
	<i>Pounds.</i>	<i>Pounds.</i>	<i>Pounds.</i>	<i>Pounds.</i>	<i>Pounds.</i>
Argentina.....	141, 094	40, 622	87, 576	122, 915	149, 792
Austria-Hungary.....	1, 618, 860, 487	1, 769, 009, 620	1, 757, 062, 893	1, 486, 611, 604	1, 334, 957, 831
Barbados.....	76, 108, 032	72, 237, 312	35, 874, 720	80, 436, 384	61, 570, 656
Belgium.....	379, 563, 242	293, 146, 385	319, 319, 090	265, 264, 520	360, 159, 071
Brazil.....	28, 346, 524	69, 615, 523	150, 978, 352	1 129, 682, 689	1 79, 824, 820
British Guiana <sup>2</sup> .....	225, 650, 880	258, 077, 120	243, 113, 920	226, 136, 960	222, 584, 992
British India.....	46, 583, 376	46, 355, 008	36, 905, 904	51, 385, 600	44, 184, 224
China.....	14, 894, 000	32, 200, 000	22, 586, 400	35, 451, 600	33, 585, 867
Cuba.....	2, 910, 438, 045	1, 991, 018, 068	3, 206, 646, 443	3, 865, 742, 384	* 3, 865, 742, 384
Dutch East Indies.....	2, 632, 224, 291	2, 823, 694, 050	2, 773, 927, 868	2, 633, 797, 407	1 2, 952, 301, 805
Egypt.....	9, 206, 512	8, 638, 868	9, 886, 572	15, 066, 587	23, 816, 750
Fiji Islands.....	149, 177, 280	148, 173, 760	136, 254, 720	138, 344, 640	163, 147, 376
France.....	731, 260, 782	540, 819, 244	535, 757, 483	423, 071, 558	1 293, 646, 106
Germany.....	2, 015, 289, 031	1, 842, 111, 731	1, 882, 598, 329	1, 543, 202, 143	1, 890, 045, 688
Guadeloupe.....	85, 892, 492	79, 487, 358	55, 582, 029	94, 505, 201	* 94, 505, 201
Martinique.....	81, 406, 568	79, 209, 012	83, 728, 753	88, 086, 424	* 88, 086, 424
Mauritius.....	431, 344, 421	434, 416, 236	395, 399, 878	475, 627, 551	522, 816, 784
Netherlands.....	299, 968, 070	339, 795, 423	336, 050, 311	321, 262, 870	432, 358, 890
Peru.....	243, 862, 499	275, 336, 866	276, 395, 900	270, 848, 265	* 270, 848, 265
Philippine Islands.....	282, 006, 295	319, 082, 784	285, 116, 244	267, 796, 166	460, 078, 408
Reunion.....	102, 513, 241	104, 132, 217	86, 815, 237	73, 854, 810	* 73, 854, 810
Russia.....	396, 915, 568	658, 262, 999	451, 906, 732	328, 232, 417	1, 000, 127, 492
Santo Domingo.....	108, 210, 326	139, 406, 516	155, 643, 131	204, 825, 241	1 193, 498, 948
Trinidad and Tobago <sup>2</sup> .....	103, 645, 472	88, 744, 992	101, 539, 200	103, 594, 736	84, 978, 544
United Kingdom.....	75, 419, 568	59, 271, 744	72, 262, 736	70, 256, 256	64, 010, 688
Other countries.....	515, 505, 000	467, 460, 000	577, 929, 000	709, 682, 000	1 496, 199, 000
Total.....	13, 564, 403, 096	12, 939, 743, 458	13, 989, 369, 421	13, 902, 888, 928	15, 107, 080, 816

## IMPORTS.

Argentina.....	95, 949, 313	91, 653, 562	43, 683, 759	125, 384, 925	114, 596, 100
Australia.....	13, 891, 696	43, 918, 224	223, 324, 304	76, 178, 592	74, 537, 344
British India.....	1, 073, 977, 072	1, 185, 089, 696	1, 254, 059, 776	1, 346, 734, 816	1, 271, 139, 184
British South Africa.....	106, 466, 060	91, 486, 806	67, 321, 877	60, 347, 661	74, 706, 959
Canada.....	445, 001, 150	439, 310, 821	522, 558, 227	534, 491, 772	599, 766, 858
Chile.....	125, 115, 503	106, 808, 229	153, 762, 051	158, 363, 803	190, 970, 283
China.....	763, 184, 133	554, 967, 467	730, 422, 533	574, 843, 733	575, 434, 133
Denmark.....	53, 082, 689	82, 652, 218	84, 324, 407	50, 303, 020	25, 478, 121
Egypt.....	54, 872, 073	117, 406, 518	108, 403, 341	71, 017, 820	100, 896, 189
Finland.....	87, 684, 973	90, 168, 804	97, 576, 050	96, 085, 928	98, 181, 156
France.....	238, 166, 609	254, 284, 000	238, 557, 561	312, 616, 689	1 379, 321, 271
Italy.....	52, 332, 354	10, 795, 265	26, 113, 267	14, 430, 871	20, 836, 116
Japan.....	439, 518, 000	443, 138, 800	298, 867, 600	267, 126, 133	175, 271, 067
Netherlands.....	196, 540, 784	141, 158, 029	156, 036, 526	141, 672, 455	204, 365, 296
New Zealand.....	75, 588, 408	102, 663, 680	116, 441, 136	115, 531, 344	123, 957, 568
Norway.....	87, 091, 555	87, 073, 278	98, 677, 191	101, 796, 435	106, 228, 453
Persia <sup>4</sup> .....	191, 423, 247	187, 302, 229	201, 246, 499	* 201, 246, 499	* 201, 246, 499
Portugal.....	72, 965, 188	73, 320, 732	77, 187, 757	72, 565, 350	* 72, 565, 350
Singapore.....	102, 551, 733	91, 263, 733	125, 340, 267	113, 436, 667	* 113, 436, 667
Switzerland.....	205, 549, 849	201, 419, 090	201, 007, 271	223, 342, 955	230, 862, 607
Turkey <sup>6</sup> .....	302, 618, 943	302, 618, 943	302, 618, 943	302, 618, 943	302, 618, 943
United Kingdom.....	3, 535, 722, 624	3, 495, 191, 616	3, 663, 325, 456	3, 587, 888, 864	3, 718, 859, 760
United States.....	3, 872, 221, 493	3, 718, 700, 796	3, 816, 896, 855	4, 195, 076, 030	4, 134, 206, 343
Uruguay <sup>7</sup> .....	46, 831, 028	57, 086, 651	* 57, 086, 651	* 57, 086, 651	* 57, 086, 651
Other countries.....	531, 965, 000	595, 478, 000	610, 738, 000	606, 705, 000	1 631, 221, 000
Total.....	12, 770, 311, 477	12, 564, 937, 187	13, 275, 577, 305	13, 406, 892, 956	13, 597, 789, 716

<sup>1</sup> Preliminary.<sup>2</sup> Year beginning Apr. 1.<sup>3</sup> Year preceding.<sup>4</sup> Year beginning Mar. 21.<sup>5</sup> Data for 1909.<sup>6</sup> Data for year beginning Mar. 14, 1905.<sup>7</sup> Year beginning July 1.<sup>8</sup> Data for 1908.

TEA.

TABLE 125.—*International trade in tea, calendar years, 1907-1911.*

["Tea" includes tea leaves only, and excludes dust, sweepings, and *yerba mate*. See "General note," p. 564.]

EXPORTS.

Country.	1907	1908	1909	1910	1911
	<i>Pounds.</i>	<i>Pounds.</i>	<i>Pounds.</i>	<i>Pounds.</i>	<i>Pounds.</i>
British India.....	234,235,767	230,560,529	244,240,817	259,111,178	265,022,376
Ceylon.....	179,843,462	179,398,312	192,886,545	182,070,094	186,594,055
China.....	211,737,333	208,879,467	199,497,467	207,324,667	194,552,800
Dutch East Indies.....	30,240,566	34,723,568	35,956,400	33,813,198	<sup>1</sup> 38,468,956
Formosa.....	21,424,544	21,887,155	22,769,573	22,211,721	<sup>2</sup> 22,211,721
Japan.....	36,191,345	31,600,943	36,949,618	39,826,886	37,096,253
Singapore.....	2,521,333	2,266,400	2,257,333	2,116,533	<sup>2</sup> 2,116,533
Other countries.....	8,091,000	6,830,000	5,577,000	6,083,000	<sup>1</sup> 6,834,000
Total.....	724,285,350	716,146,374	740,134,753	752,557,277	752,896,694

IMPORTS.

Argentina.....	2,833,643	4,145,373	3,792,494	3,755,119	3,672,050
Australia.....	35,174,152	29,873,772	31,617,111	36,727,700	34,759,385
Austria-Hungary.....	3,090,408	3,104,297	3,183,442	3,019,420	3,550,508
British India.....	5,963,722	7,594,751	3,615,261	7,829,226	10,748,451
British South Africa.....	4,613,177	4,613,065	4,364,868	5,139,350	5,534,164
Canada.....	28,840,872	30,772,138	40,143,248	37,430,954	33,424,715
Chile.....	2,380,869	2,320,498	2,832,664	3,408,254	3,625,403
China.....	17,993,067	13,688,800	16,421,867	17,054,800	16,630,000
Dutch East Indies.....	5,443,167	5,740,211	5,774,441	6,148,570	<sup>1</sup> 6,276,269
France.....	2,546,057	2,502,532	2,732,381	2,779,119	<sup>1</sup> 2,962,101
French Indo-China.....	2,754,275	2,964,539	2,693,845	2,859,227	<sup>2</sup> 2,859,227
Germany.....	8,680,833	8,828,100	10,937,462	6,894,005	8,404,817
Netherlands.....	9,202,719	10,234,005	10,299,053	10,955,943	11,466,387
New Zealand.....	6,760,969	6,471,963	7,302,310	7,582,308	8,071,471
Persia <sup>3</sup> .....	9,782,414	7,477,820	8,127,241	<sup>4</sup> 8,127,241	<sup>4</sup> 8,127,241
Russia.....	204,713,749	192,109,515	162,348,704	154,703,804	153,288,472
Singapore.....	4,842,133	4,763,867	5,191,600	5,244,533	<sup>2</sup> 5,244,533
United Kingdom.....	273,984,050	275,417,319	283,547,798	287,078,453	293,502,178
United States.....	99,117,343	90,930,621	104,484,550	98,108,939	104,165,654
Other countries.....	26,270,000	27,269,000	27,164,000	35,919,000	<sup>1</sup> 37,448,000
Total.....	754,987,619	730,822,186	736,574,340	740,815,965	753,761,026

<sup>1</sup> Preliminary.  
<sup>2</sup> Year preceding.

<sup>3</sup> Year beginning Mar. 21.  
<sup>4</sup> Data for 1909.

TABLE 126.—Wholesale price of tea per pound, by months, on New York market, 1908-1912.

Date.	Footow, fair to fine.		Formosa, fine to choice.		Japans, pan-fired.		India-orange pekoe.		Ceylon-orange pekoe.	
	Low.	High.	Low.	High.	Low.	High.	Low.	High.	Low.	High.
1908.										
January.....	Cents. 13	Cents. 21	Cents. 22	Cents. 45	Cents. 19	Cents. 34	Cents. 17	Cents. 25	Cents. 18	Cents. 30
February.....	13	21	22	45	19	35	17	25	18	30
March.....	13	21	22	45	19	34	17	25	18	30
April.....	13	21	22	45	18	34	17	25	18	30
May.....	13	21	22	45	18	34	17	25	18	30
June.....	13	21	22	45	18	35	17	25	18	30
July.....	13	21	22	45	18	34	17	25	18	30
August.....	13	21	22	45	18	35	17	25	18	30
September.....	13	21	22	45	18	35	17	25	18	30
October.....	12½	21	20	45	18	35	17	25	18	30
November.....	12½	21	20	40	18	34	20	25	19	22
December.....	12½	21	20	40	18	34	20	25	19	22
Year.....	12½	21	20	45	18	35	17	25	18	30
1909.										
January.....	12½	21	20	40	18	34	20	25	19	22
February.....	12½	21	20	40	23	35	20	25	19	22
March.....	13	27	20	40	19	38	20	26	19	26
April.....	16	27	25	40	22	38	18	26	20	26
May.....	14	27	24	40	22	35	18	24	19	28
June.....	14	27	24	40	21½	35	18	24	19	28
July.....	14	27	24	40	21½	35	18	24	19	28
August.....	11½	27	24	40	18	35	18	24	18	28
September.....	11½	27	24	40	18	34	18	24	18	21
October.....	12	27	24	40	18	34	18	24	18	21
November.....	12½	27	24	40	18	35½	18	24	18	24
December.....	12½	27	23½	40	19	35½	18	24	18	24
Year.....	12½	27	20	40	18	38	18	26	18	28
1910.										
January.....	12½	27	23½	40	19	35½	18	24	18	24
February.....	12½	27	23½	64½	18	35	18	24	18	24
March.....	12½	27	23½	64½	17½	35	18	26½	18	26
April.....	12½	22	23½	40	17½	33	18	26½	18	26
May.....	12	22	23½	40	17½	33	18	26½	18	26
June.....	12	22	23½	40	17½	33	18	26½	18	26
July.....	12	22	23½	40	17½	36	18	26½	18	26
August.....	12	22	23½	40	18	36	18	26½	18	26
September.....	10½	22	23	40	18	36	18	26½	18	26
October.....	11	22	23	40	20	25	18	26½	18	26
November.....	10½	22	23	40	20	25	18	26½	18	26
December.....	10½	22	23½	40	20	25	18	26½	18	26
Year.....	10½	27	23	64½	17½	36	18	26½	18	26
1911.										
January.....	10½	22	23½	40	20	26	18	26½	18	26
February.....	11½	22	23½	40	19	28	18	26½	18	26
March.....	11½	22	23½	40	19	20	18	26½	18	26
April.....	11½	22	23½	40	19	20	18	26½	18	26
May.....	10	22	23½	45	17	20	18	26½	18	26
June.....	10	22	25	45	17	18	19	25	20	26
July.....	10	22	25	45	17	19	19	25	20	26
August.....	11	22	25	45	19	19	19	25	20	26
September.....	11½	22½	24	45½	19	19	19	25	20	26
October.....	12½	22½	24½	39	19	32	19	25	20	26
November.....	15	22½	24	39	21	32	19	25	20	26
December.....	14	22½	24	39	20	32	19	25	20	26
Year.....	10	22½	23½	45½	17	32	18	26½	18	26
1912.										
January.....	13	22½	22	39	20	21	19	25	20	26
February.....	12	21	20	39	18½	19	19	25	20	26
March.....	12½	21	20	39	17	19	19	25	20	26
April.....	12½	21	20	39	18½	19	19	25	20	26
May.....	11½	21	20	39	15	17½	18	25	20	26
June.....	11½	21	23	39	15	15½	18	25	20	26
July.....	12	21	23	39	15	16½	18	25	20	26
August.....	12	21	23	39	15	16	18	25	20	26
September.....	12	21	23	39	15	16	18	25	20	26
October.....	12	21	23	39	15	16	18	25	20	26
November.....	12	21	23	39	15	18	18	25	20	26
December.....	11	17	23	25	17	18	18	25	20	26
Year.....	11½	22½	20	39	15	21	18	25	20	26

## COFFEE.

TABLE 127.—Coffee crop of countries named, 1907-1911.

Country.	1907	1908	1909	1910	1911
<b>NORTH AMERICA.</b>					
United States:	<i>Pounds.</i>	<i>Pounds.</i>	<i>Pounds.</i>	<i>Pounds.</i>	<i>Pounds.</i>
Porto Rico <sup>1</sup> .....	35,256,000	28,490,000	45,210,000	33,937,000	40,146,000
Hawaii <sup>1</sup> .....	1,442,000	1,963,000	2,702,000	3,460,000	2,486,000
Total.....	36,698,000	30,453,000	47,912,000	37,397,000	42,632,000
<b>CENTRAL AMERICA.</b>					
Guatemala.....	89,232,000	82,134,000	81,120,000	270,891,000	290,000,000
Costa Rica <sup>2</sup> .....	38,199,000	19,792,000	26,522,000	27,503,000	27,869,000
Nicaragua.....	20,000,000	17,900,000	218,610,000	226,943,000	326,943,000
Salvador.....	56,320,000	157,589,000	163,310,000	162,764,000	362,764,000
Honduras.....	5,000,000	5,000,000	5,000,000	5,000,000	5,000,000
British Honduras <sup>4</sup> .....	10,000	10,000	10,000	10,000	( <sup>5</sup> )
Total.....	208,761,000	182,425,000	195,092,000	193,111,000	212,576,000
Mexico.....	45,000,000	42,000,000	81,000,000	70,000,000	70,000,000
<b>WEST INDIES.</b>					
Haiti <sup>6</sup> .....	59,825,000	63,848,000	40,974,000	79,425,000	53,100,000
Santo Domingo <sup>2</sup> .....	3,411,000	4,081,000	1,542,000	4,550,000	34,550,000
Trinidad.....	79,000	74,000	24,000	21,000	22,000
Jamaica.....	710,551,000	77,885,000	28,254,000	29,782,000	26,726,000
Guadeloupe.....	1,903,000	1,903,000	1,903,000	2,500,000	22,115,000
Cuba.....	6,596,000	( <sup>5</sup> )	( <sup>5</sup> )	( <sup>5</sup> )	( <sup>5</sup> )
Leeward Islands (British) <sup>2</sup> .....	3,000	5,000	2,000	3,000	9,000
Total.....	82,298,000	77,726,000	52,679,000	98,261,000	66,502,000
Total North America.....	372,757,000	332,604,000	376,683,000	396,769,000	391,710,000
<b>SOUTH AMERICA.</b>					
Brazil <sup>2</sup> .....	2,074,151,000	1,674,416,000	2,232,926,000	1,286,217,000	1,489,137,000
Venezuela <sup>2</sup> .....	96,279,000	91,702,000	103,256,000	96,655,000	97,659,000*
Colombia.....	92,593,000	92,593,000	92,593,000	95,000,000	85,000,000
Bolivia.....	1,500,000	1,500,000	1,500,000	1,500,000	1,500,000
Ecuador.....	2,520,000	8,349,000	7,540,000	8,682,000	8,000,000
Peru <sup>2</sup> .....	1,842,000	1,619,000	736,000	978,000	3978,000
Dutch Guiana.....	522,000	1,109,000	552,000	357,000	337,000
British Guiana.....	( <sup>5</sup> )	89,000	97,000	108,000	136,000
Total South America.....	2,269,407,000	1,871,377,000	2,439,200,000	1,489,497,000	1,682,767,000
<b>ASIA.</b>					
Dutch East Indies <sup>4</sup> .....	36,899,000	44,524,000	33,222,000	34,903,000	48,190,000
Federated Malay States: <sup>2</sup>					
Perak.....	26,000	2,000	1,000	( <sup>9</sup> )	( <sup>9</sup> )
Selangor.....	2,281,000	2,334,000	1,757,000	1,486,000	1,443,000
Negri Sembilan.....	259,000	94,000	43,000	15,000	( <sup>9</sup> )
Total.....	2,566,000	2,430,000	1,801,000	1,501,000	1,443,000
British India <sup>4</sup> .....	33,051,000	33,826,000	27,648,000	34,984,000	27,002,000
Ceylon.....	420,000	310,000	2116,000	293,000	238,000
British North Borneo <sup>2</sup> .....	3,000	4,000	3,000	1,000	1,000
Sarawak <sup>2</sup> .....	26,000	22,000	17,000	16,000	14,000
Arabia (Aden) <sup>8</sup> .....	14,377,000	15,670,000	15,276,000	15,374,000	315,374,000
Total Asia.....	87,342,000	96,786,000	78,083,000	86,872,000	92,062,000

<sup>1</sup> Exports, year beginning July 1.<sup>2</sup> Exports, year beginning Jan. 1.<sup>3</sup> Year preceding.<sup>4</sup> Partial returns.<sup>5</sup> No data.<sup>6</sup> Exports, year beginning Oct. 1.<sup>7</sup> Exports, year ending Mar. 31 of the year following that stated.<sup>8</sup> Exports, year beginning Apr. 1.<sup>9</sup> Less than 1,000 pounds.

TABLE 127.—Coffee crop of countries named, 1907-1911—Continued.

Country.	1907	1908	1909	1910	1911
AFRICA.					
	<i>Pounds.</i>	<i>Pounds.</i>	<i>Pounds.</i>	<i>Pounds.</i>	<i>Pounds.</i>
Somaliland <sup>1</sup> .....	198,000	245,000	399,000	208,000	76,000
Southern Nigeria <sup>2</sup> .....	39,000	37,000	70,000	47,000	12,000
Nyasaland Protectorate.....	885,000	1,011,000	774,000	308,000	1,786,000
German East Africa <sup>2</sup> .....	1,393,000	2,228,000	<sup>3</sup> 2,228,000	<sup>3</sup> 2,228,000	2,594,000
Somali Coast <sup>2</sup> .....	7,257,000	5,767,000	5,893,000	<sup>3</sup> 5,893,000	<sup>3</sup> 5,893,000
Liberia.....	2,000,000	2,000,000	2,000,000	2,000,000	2,000,000
Abyssinia.....	10,000,000	10,000,000	10,000,000	10,000,000	10,000,000
Uganda Protectorate <sup>1</sup> .....	13,000	22,000	33,000	200,000	192,000
Sierra Leone.....	16,000	21,000	7,000	23,000	<sup>2</sup> 24,000
Union of South Africa.....				26,000	75,000
Natal.....	28,000	19,000	4,000	( <sup>4</sup> )	( <sup>4</sup> )
Seychelles <sup>2</sup> .....	7,000	6,000	2,000	2,000	1,000
Gold Coast <sup>2</sup> .....	1,000	( <sup>5</sup> )	( <sup>5</sup> )	( <sup>5</sup> )	( <sup>5</sup> )
Belgian Congo <sup>2</sup> .....	161,000	91,000	28,000	18,000	6,000
East African Protectorate <sup>1</sup> .....	( <sup>4</sup> )	19,000	71,000	137,000	234,000
Total Africa.....	21,998,000	21,466,000	21,509,000	21,090,000	21,893,000
OCEANIA.					
New Caledonia <sup>2</sup> .....	721,000	783,000	1,017,000	<sup>3</sup> 1,017,000	1,431,000
Queensland.....	112,000	116,000	89,000	151,000	81,000
Papua <sup>2</sup> .....	39,000	27,000	13,000	( <sup>4</sup> )	( <sup>4</sup> )
Total Oceania.....	872,000	926,000	1,119,000	1,168,000	1,512,000
Grand total.....	2,752,376,000	2,323,159,000	2,916,594,000	1,995,396,000	2,189,944,000

<sup>1</sup> Exports, year beginning Apr. 1.<sup>2</sup> Exports, year beginning Jan. 1.<sup>3</sup> Year preceding.<sup>4</sup> No data.<sup>5</sup> Less than 1,000 pounds.

TABLE 128.—Total production of coffee in countries named in Table 127, 1904-1911.

Year.	Production.	Year.	Production.	Year.	Production.
	<i>Pounds.</i>		<i>Pounds.</i>		<i>Pounds.</i>
1904.....	1,973,552,000	1907.....	2,752,376,000	1910.....	1,995,396,000
1905.....	2,146,253,000	1908.....	2,323,159,000	1911.....	2,189,944,000
1906.....	2,582,788,000	1909.....	2,916,594,000		

TABLE 129.—Wholesale price of coffee per pound, by months, on the New York and New Orleans markets, 1908-1912.

Date.	New York.												New Orleans.				
	Rio No. 7.		Santos No. 7.		Mocha.		Padang.		Cucuta, washed.		Mexican Cordoba, washed.		Rio No. 7.		Santos No. 7.		
	Low.	High.	Low.	High.	Low.	High.	Low.	High.	Low.	High.	Low.	High.	Low.	High.	Low.	High.	
1908.	Cts.	Cts.	Cts.	Cts.	Cts.	Cts.	Cts.	Cts.	Cts.	Cts.	Cts.	Cts.	Cts.	Cts.	Cts.	Cts.	Cts.
January.....	6	7½	6	7½	17	19	20	21	10½	13½	10½	13	5½	6½	7	7½	7½
February.....	6½	7½	6½	7½	17	19	19	21	10½	13½	10½	13	5½	6½	7	7½	7½
March.....	6	7½	6	7½	16½	19	20	21	10	13½	10½	13	5½	6	7	7½	7½
April.....	6	7½	6	7½	16½	19	19	21	10	13½	10½	12½	5½	6	7	7½	7½
May.....	6	7½	6	7½	16½	19	19	20	10	13½	10½	12½	5½	6	7	7½	7½
June.....	6½	7½	6½	7½	14½	19	19	20	10	13½	10½	12½	5	6	7	7½	7½
July.....	6½	7	6½	7	14½	17	19	20	10	13	10½	13	5½	6	7	7½	7½
August.....	6½	7½	6½	7½	15	17	19	20	10½	13½	10½	13	5½	6	7	7½	7½
September.....	6	7½	6	7½	15	17	10	20	10½	13	10½	13	5½	6	7	7½	7½
October.....	6	7½	6	7½	15	17	10	20	10½	13	10½	13	6	6½	7	7½	7½
November.....	6½	7½	6½	7½	15	17	10	20	10½	12½	10½	13	6	6½	7	7½	7½
December.....	6½	7	6½	7	15	17	10	20	10½	12½	10½	13	6	6½	7	7½	7½
Year.....	6	7½	6	7½	14½	19	10	21	10	13½	10½	13	5½	6½	7	7½	7½

TABLE 129.—Wholesale price of coffee per pound, by months, on the New York and New Orleans markets, 1908-1912—Continued.

Date.	New York.										New Orleans.						
	Rio No. 7.		Santos No. 7.		Mocha.		Padang.		Cucuta, washed.		Mexican Cordoba, washed.		Rio No. 7.		Santos No. 7.		
	Low.	High.	Low.	High.	Low.	High.	Low.	High.	Low.	High.	Low.	High.	Low.	High.	Low.	High.	
1909.	Cts.	Cts.	Cts.	Cts.	Cts.	Cts.	Cts.	Cts.	Cts.	Cts.	Cts.	Cts.	Cts.	Cts.	Cts.	Cts.	Cts.
January	6½	7½	6½	7½	15	17	10	20	10½	14	10½	13	7½	7½	7½	7½	7½
February	7½	8½	7½	8½	15	17	10	20	11	14	11	13½	7½	7½	7½	7½	7½
March	8½	9½	8½	9½	14½	17	18	20½	11½	14	12	13½	8½	8½	8½	8½	8½
April	8½	9½	8½	9½	14	17	18	20½	11½	14	10½	13	8½	8½	8½	8½	8½
May	7½	8½	7½	8½	14	16	18	20½	11½	14	10½	12½	8	8	8	8	8
June	7½	8½	7½	8½	14	16	18	20	10	14	10½	12½	7½	7½	7½	7½	7½
July	7½	8½	7½	8½	14	16	16½	16½	10	13	10½	12½	7½	7½	7½	7½	7½
August	7½	8½	7½	8½	15	16½	16½	16½	9½	12	11	13	7½	7½	7½	7½	7½
September	7½	8½	7½	8½	15	16½	16½	19½	9	12	11	13½	7½	7½	7½	7½	7½
October	7½	8½	7½	8½	15½	16½	16½	19½	10	12	11½	13½	7½	7½	7½	7½	7½
November	8½	9½	8½	9½	14½	16½	16½	20	10	12	11	13½	8½	8½	8½	8½	8½
December	8½	9½	8½	9½	14½	16	16½	20	10	12	10½	13	8½	8½	8½	8½	8½
Year	6½	8½	6½	8½	14	17	10	20½	9½	14	10½	13½	7½	8½	7½	8½	8½
1910.	8½	9½	8½	9½	14½	16½	17½	20	10	12	10½	12½	8½	8½	8½	8½	8½
January	8½	9½	8½	9½	15	16½	18	20	10½	12	10½	12½	8½	8½	8½	8½	8½
February	8½	9½	8½	9½	14½	16½	17½	20	10	12	11	12½	8½	8½	8½	8½	8½
March	8½	9½	8½	9½	14½	16½	17½	19½	10	12	11	12½	8½	8½	8½	8½	8½
April	8½	9½	8½	9½	14½	16½	16½	19½	10	12	11	12½	8½	8½	8½	8½	8½
May	8	9	8	9	14	16½	17	19½	10	12	11	12½	8½	8½	8½	8½	8½
June	8	9	8	9	14	16½	17	19½	10	12	11	12½	8½	8½	8½	8½	8½
July	8½	9½	8½	9½	14½	16½	17	19½	10	12	11	12½	8½	8½	8½	8½	8½
August	8½	9½	8½	9½	14½	16½	17	19½	10½	12½	11	13	8½	8½	8½	8½	8½
September	10	11	10½	11½	14½	16½	17½	19½	11	14	11½	14	10	11	10½	11½	11½
October	10½	11	11	11½	15	17	17½	20	13	14½	12½	14	11	11½	11½	11½	11½
November	10½	13½	11	13	15½	17	17½	20	13½	16½	13	15½	11	13½	11½	13½	13½
December	13	13½	13½	13½	15	17½	18	20	14½	15½	14½	15½	13½	13½	13½	13½	13½
Year	8	13½	8½	13½	14½	17½	17	20	10	16½	10½	15½	8½	13½	8½	13½	13½
1911.	12½	13½	13½	14	15½	16½	18½	20	14½	15½	14½	16	13½	13½	13½	13½	13½
January	12½	13½	13½	14	15½	16½	18½	19½	14½	15½	14½	16	13½	13½	13½	13½	13½
February	12½	13½	13½	14	15½	16½	18½	19½	14½	15½	14½	16	13½	13½	13½	13½	13½
March	12½	13½	13½	14	15½	16½	18½	19½	14½	15½	14½	16	13½	13½	13½	13½	13½
April	11½	12½	12½	13	15	16½	18½	19½	13½	14½	14½	15½	15	12½	12½	12½	12½
May	11½	12½	12½	13	15	16½	18½	19½	13½	14½	14½	15½	15	12½	12½	12½	12½
June	12½	13	12½	13	16	17½	18½	19½	14½	15½	14½	15½	15	12½	13	12½	13
July	13	13½	13	13½	16	17½	18½	19½	14½	15½	15½	16½	15	13	13	13	13
August	13	13½	13	13½	16	17½	18½	19½	14½	15½	15½	16½	15	13	13	13	13
September	13½	14	13½	14½	16½	18	18½	21	14½	16½	15½	16½	15	13	14	13	14
October	14	16½	14½	16½	16½	18	18	20	14½	18	16	18	14	14	14	14	14
November	14½	15½	15½	16½	18½	20	20	22	16½	18	17½	18	14	14	15	15	15
December	14½	15½	14½	16	18½	19½	20	21	15½	18	17½	18	14	14	14	14	14
Year	11½	16½	12½	16½	18½	20	18½	22	13½	18	14½	18½	11½	16½	12½	16½	16½
1912.	13½	14½	14½	14½	18½	19½	20	21	15½	17	17½	18	13½	14½	14½	14½	14½
January	14½	14½	14½	14½	18½	19½	20	22	15½	18½	17½	18	14½	14½	14½	14½	14½
February	14½	14½	15½	15½	18½	19½	21	22	16	18½	18	18½	14½	15	14½	14½	14½
March	14½	15	14½	15	18½	19½	21	22	16	18½	18	18½	14½	14½	14½	14½	14½
April	14½	14½	14½	15	18½	19½	21	22	16	18½	18	18½	14½	14½	14½	14½	14½
May	14½	14½	14½	15	18½	19½	21	22	16	18½	18	18½	14½	14½	14½	14½	14½
June	14½	14½	14½	15	18½	19½	21	22	16	18½	18	18½	14½	14½	14½	14½	14½
July	14	14½	14½	15	18½	19½	21	22	16	18½	18	18½	14½	14½	14½	14½	14½
August	14	14½	14½	15	18½	19½	21	22	16	18½	18	18½	14½	14½	14½	14½	14½
September	14	15	15	16	19	20½	20	21	15½	18	16½	17½	14	14½	14½	14½	14½
October	14½	15½	15½	16½	19½	20½	20	21	16	18½	17	17½	14½	14½	14½	14½	14½
November	14½	15½	15½	16	19½	20½	20	21	16	18½	17	17½	14½	14½	14½	14½	14½
December	14	14½	13½	15½	19½	21	20	21	16	18	15½	18½	14	14	14	14	14
Year	13½	15½	14½	16½	18½	21	19½	22	15½	18½	15½	18½	13½	15½	14½	16½	16½



TABLE 130.—*International trade in coffee, calendar years 1907–1911.*

[The item of coffee comprises unhulled and hulled, roasted, ground, or otherwise prepared, but imitation or "surrogate" coffee and chicory are excluded. See "General note," p. 564.]

## EXPORTS.

Country.	1907	1908	1909	1910	1911
	<i>Pounds.</i>	<i>Pounds.</i>	<i>Pounds.</i>	<i>Pounds.</i>	<i>Pounds.</i>
Belgium.....	34,493,527	38,461,006	33,507,782	28,531,056	28,112,984
Brazil.....	2,074,150,557	1,674,415,843	2,232,925,401	1,286,217,168	1,489,137,017
British India.....	17,866,128	37,568,832	23,625,504	33,669,776	24,593,408
Colombia <sup>2</sup> .....	90,000,000	90,000,000	90,000,000	90,000,000	90,000,000
Costa Rica.....	38,199,206	19,791,865	26,521,567	27,502,788	27,868,693
Dutch East Indies.....	55,997,691	56,805,642	44,346,964	34,900,880	1,521,517,307
Guatemala.....	95,628,200	60,720,000	92,990,000	70,891,294	90,000,000
Haiti <sup>3</sup> .....	59,824,869	63,848,333	40,973,613	79,424,512	1,53,100,000
Jamaica <sup>4</sup> .....	10,551,184	7,885,248	8,253,616	9,782,528	6,725,712
Mexico.....	29,979,701	52,590,541	54,874,939	48,265,376	5,48,265,376
Netherlands.....	177,010,282	179,443,126	193,098,597	173,823,451	195,902,019
Nicaragua.....	5,19,418,734	20,643,667	18,609,741	26,942,720	6,23,942,720
Salvador <sup>5</sup> .....	58,751,356	57,589,360	63,330,077	62,784,000	5,62,764,000
Singapore.....	6,314,400	6,765,200	5,488,267	3,964,533	3,964,533
United States.....	41,802,527	34,238,012	35,089,526	47,159,055	36,383,953
Venezuela.....	96,278,773	91,702,308	103,256,068	96,655,341	97,658,703
Other countries.....	29,571,000	50,388,000	38,462,000	31,040,000	1,36,380,000
Total.....	2,945,838,135	2,542,886,983	3,105,354,662	2,151,534,478	2,370,316,425

## IMPORTS.

Argentina.....	21,625,439	22,085,751	25,548,267	26,931,182	24,481,677
Austria-Hungary.....	131,929,437	121,778,797	126,991,574	131,835,741	127,196,161
Belgium.....	250,279,514	134,656,730	126,319,127	110,565,924	93,176,925
British South Africa.....	23,686,674	25,321,709	27,727,936	26,629,533	24,954,103
Cuba.....	23,250,910	24,432,111	25,407,861	26,598,543	6,26,598,543
Denmark.....	28,141,719	29,072,722	33,020,499	32,554,446	32,207,663
Egypt.....	14,976,416	21,146,076	18,994,922	14,379,781	15,147,710
Finland.....	29,007,490	28,549,158	30,191,968	27,970,382	28,255,397
France.....	223,930,047	226,557,480	237,975,547	246,544,386	1,244,829,648
Germany.....	418,369,588	425,328,407	470,923,724	376,867,993	404,034,617
Italy.....	47,356,351	50,189,262	53,121,381	55,762,491	58,391,256
Netherlands.....	259,827,454	262,476,852	288,284,852	264,745,621	289,272,720
Norway.....	28,838,284	27,186,069	31,675,494	29,338,865	29,431,108
Russia.....	25,281,343	25,691,765	25,757,852	25,556,667	25,219,302
Singapore.....	7,397,600	7,405,067	6,632,133	4,740,667	5,4,740,667
Spain.....	24,902,141	27,373,085	27,070,627	28,311,268	28,325,699
Sweden.....	71,239,323	66,898,975	92,267,883	65,164,883	71,844,764
Switzerland.....	25,201,885	24,436,227	26,515,606	25,512,293	23,707,387
United Kingdom.....	29,242,982	29,195,788	29,591,296	29,195,770	28,028,656
United States.....	940,247,312	938,559,889	1,139,826,171	804,417,451	800,208,533
Other countries.....	95,071,000	98,942,000	105,957,000	87,861,000	1,78,545,000
Total.....	2,719,802,909	2,617,283,920	2,949,801,720	2,441,484,887	2,458,597,536

<sup>1</sup> Preliminary.

<sup>2</sup> Unofficial estimate.

<sup>3</sup> Estimated from data furnished by Haitian legation. Year beginning Oct. 1.

<sup>4</sup> Year beginning Apr. 1.

<sup>5</sup> Year preceding.

<sup>6</sup> Year beginning July 1.

OIL CAKE AND OIL-CAKE MEAL.

TABLE 131.—*International trade in oil cake and oil-cake meal, calendar years 1907–1911.*

[The class called here "oil cake and oil-cake meal" includes the edible cake and meal remaining after making oil from such products as cotton seed, flaxseed, peanuts, corn, etc. See "General note," p. 564.]

EXPORTS.

Country.	1907	1908	1909	1910	1911
	<i>Pounds.</i>	<i>Pounds.</i>	<i>Pounds.</i>	<i>Pounds.</i>	<i>Pounds.</i>
Argentina.....	26, 703, 043	31, 867, 493	36, 750, 682	46, 549, 856	44, 594, 296
Austria-Hungary.....	93, 135, 532	113, 951, 144	115, 295, 289	111, 420, 043	158, 739, 137
Belgium.....	146, 624, 650	149, 097, 446	153, 062, 212	166, 846, 826	174, 256, 679
British India.....	127, 675, 168	158, 531, 296	164, 075, 296	143, 717, 056	159, 808, 768
Canada.....	44, 286, 700	41, 743, 700	42, 774, 000	42, 246, 700	36, 945, 700
China.....	132, 974, 800	129, 166, 933	140, 888, 933	161, 685, 333	147, 064, 800
Denmark.....	4, 888, 953	2, 757, 514	9, 378, 148	10, 492, 132	16, 212, 849
Egypt.....	145, 536, 669	148, 647, 360	166, 676, 578	136, 751, 338	187, 772, 395
France.....	312, 332, 516	329, 689, 773	410, 340, 434	469, 152, 989	1 465, 864, 608
Germany.....	396, 191, 091	414, 851, 487	431, 040, 085	450, 594, 667	514, 189, 220
Italy.....	16, 882, 165	47, 729, 370	51, 145, 397	33, 395, 942	89, 839, 434
Mexico.....	60, 020, 308	40, 896, 304	17, 955, 693	41, 310, 271	2 41, 310, 271
Netherlands.....	206, 331, 788	156, 917, 844	158, 760, 889	247, 885, 063	210, 956, 236
Russia.....	1, 164, 122, 145	1, 460, 057, 008	1, 373, 467, 577	1, 269, 157, 705	1, 452, 290, 914
United Kingdom.....	49, 669, 760	36, 910, 720	247, 452, 800	392, 945, 280	46, 336, 640
United States.....	1, 959, 101, 228	1, 959, 213, 339	1, 488, 233, 547	1, 461, 500, 675	1, 638, 536, 925
Other countries.....	68, 122, 000	88, 000, 000	107, 819, 000	56, 168, 000	1 60, 243, 000
Total.....	4, 954, 498, 519	5, 310, 028, 731	5, 115, 116, 560	5, 241, 819, 876	5, 444, 961, 873

IMPORTS.

Austria-Hungary.....	36, 586, 262	27, 152, 295	37, 056, 460	29, 300, 457	48, 057, 855
Belgium.....	423, 937, 567	553, 061, 439	534, 676, 433	552, 282, 540	529, 596, 468
Canada.....	4, 290, 000	3, 741, 000	5, 024, 100	5, 391, 500	6, 662, 000
Denmark.....	947, 738, 801	1, 036, 940, 224	1, 046, 131, 201	651, 996, 781	948, 132, 542
Dutch East Indies.....	21, 089, 281	14, 133, 614	7, 226, 002	2, 587, 872	1 2, 229, 624
Finland.....	23, 856, 839	20, 872, 970	22, 013, 822	21, 457, 187	25, 587, 518
France.....	247, 777, 860	200, 276, 446	273, 874, 372	290, 590, 751	1 314, 795, 275
Germany.....	1, 573, 591, 451	1, 463, 985, 133	1, 612, 275, 568	1, 573, 936, 030	1, 668, 379, 551
Italy.....	10, 577, 891	10, 834, 507	13, 299, 690	12, 429, 976	11, 872, 432
Japan.....	162, 850, 133	139, 939, 333	125, 114, 400	154, 296, 287	195, 154, 267
Netherlands.....	639, 966, 526	701, 175, 545	627, 553, 310	675, 617, 307	643, 155, 253
Norway.....	41, 243, 260	45, 376, 554	38, 410, 878	41, 888, 083	63, 452, 511
Sweden.....	316, 546, 651	257, 927, 499	316, 504, 532	323, 490, 312	357, 198, 203
Switzerland.....	52, 728, 300	55, 160, 415	61, 136, 424	67, 061, 948	88, 450, 757
United Kingdom.....	731, 057, 600	736, 330, 560	730, 833, 600	700, 483, 840	754, 779, 206
Other countries.....	63, 978, 000	60, 935, 000	63, 026, 000	27, 766, 000	1 30, 021, 000
Total.....	5, 297, 616, 422	5, 327, 842, 534	5, 514, 156, 812	5, 130, 546, 851	5, 687, 524, 456

<sup>1</sup> Preliminary.

<sup>2</sup> Year preceding.

ROSIN.

TABLE 132.—*International trade in rosin, calendar years, 1907–1911.*

[For rosin, only the resinous substance, known as "rosin" in the exports of the United States, is taken. See "General note," p. 564.]

EXPORTS.

Country.	1907	1908	1909	1910	1911
	<i>Pounds.</i>	<i>Pounds.</i>	<i>Pounds.</i>	<i>Pounds.</i>	<i>Pounds.</i>
Austria-Hungary.....	3, 019, 420	2, 631, 851	2, 292, 784	2, 031, 318	1, 988, 108
Belgium <sup>1</sup> .....					46, 345, 864
Germany.....	55, 018, 659	60, 957, 851	48, 019, 054	55, 682, 244	52, 353, 738
Greece.....	5, 517, 676	3, 754, 883	4, 533, 879	12, 334, 962	17, 201, 969
Netherlands.....	76, 672, 888	86, 767, 765	56, 629, 686	55, 813, 677	62, 976, 231
Russia.....	48, 889, 870	39, 151, 403	25, 314, 820	38, 545, 178	47, 317, 266
Spain.....	17, 350, 700	16, 910, 360	14, 891, 368	22, 568, 596	19, 508, 814
United States.....	738, 121, 720	728, 330, 680	555, 667, 000	635, 414, 920	676, 323, 200
Other countries.....	770, 000	1, 380, 000	1, 098, 000	722, 000	2 327, 000
Total.....	945, 360, 933	939, 884, 793	708, 446, 591	823, 112, 895	924, 342, 190

<sup>1</sup> Not separately stated prior to 1911.

TABLE 132.—*International trade in rosin, calendar years, 1907–1911—Continued.*

## IMPORTS.

Country.	1907	1908	1909	1910	1911
	<i>Pounds.</i>	<i>Pounds.</i>	<i>Pounds.</i>	<i>Pounds.</i>	<i>Pounds.</i>
Argentina.....	23, 205, 941	23, 528, 891	28, 189, 541	28, 818, 108	30, 674, 099
Australia.....	15, 618, 176	18, 015, 312	9, 041, 200	14, 525, 392	15, 064, 336
Austria-Hungary.....	74, 316, 184	82, 323, 291	70, 230, 179	70, 959, 019	80, 856, 130
Belgium <sup>1</sup> .....					79, 432, 311
Brazil.....	26, 829, 283	34, 133, 661	33, 919, 843	33, 919, 843	33, 919, 843
British India.....	7, 338, 016	7, 120, 176	6, 546, 624	5, 733, 056	5, 516, 672
Canada.....	21, 856, 300	17, 004, 000	22, 967, 200	23, 922, 600	25, 797, 400
Chile.....	8, 950, 354	4, 840, 078	7, 684, 393	6, 661, 508	7, 744, 919
Cuba.....	3, 709, 872	2, 520, 314	2, 848, 506	3, 190, 188	3, 199, 188
Denmark.....	2, 439, 390	2, 382, 070	3, 044, 553	3, 124, 359	3, 170, 215
Dutch East Indies.....	13, 148, 565	13, 544, 974	11, 681, 997	14, 025, 365	14, 727, 592
Finland.....	7, 509, 410	7, 042, 030	4, 370, 282	5, 251, 915	7, 794, 610
Germany.....	247, 630, 152	286, 215, 061	216, 806, 316	240, 231, 735	246, 054, 038
Italy.....	33, 591, 490	38, 810, 660	23, 571, 583	32, 847, 217	36, 950, 860
Japan.....	7, 120, 556	8, 035, 458	4, 738, 545	8, 151, 959	10, 235, 131
Netherlands.....	90, 919, 686	98, 808, 607	63, 619, 681	64, 646, 156	78, 441, 824
Norway.....	4, 879, 706	6, 100, 238	6, 143, 294	6, 596, 450	6, 537, 212
Roumania.....	4, 500, 534	4, 984, 545	3, 659, 224	4, 649, 049	4, 649, 049
Russia.....	67, 943, 055	75, 526, 599	56, 329, 359	62, 615, 984	73, 782, 206
Servia.....	4, 562, 717	473, 541	3, 643, 860	405, 999	586, 298
Spain.....	3, 258, 231	2, 907, 147	3, 218, 374	2, 535, 581	1, 959, 537
Switzerland.....	5, 270, 978	4, 626, 574	4, 469, 386	4, 866, 214	4, 988, 569
United Kingdom.....	177, 534, 336	171, 698, 688	148, 453, 648	159, 296, 032	158, 346, 384
Uruguay <sup>6</sup> .....	4, 881, 183	5, 836, 727	5, 836, 727	5, 836, 727	5, 836, 727
Other countries.....	4, 951, 000	7, 952, 000	9, 345, 000	10, 963, 000	13, 206, 000
Total.....	861, 965, 115	924, 430, 642	750, 359, 315	813, 782, 456	943, 471, 155

<sup>1</sup> Not separately stated prior to 1911.<sup>3</sup> Year preceding.<sup>5</sup> Year beginning July 1.<sup>2</sup> Data for 1909.<sup>4</sup> Preliminary.<sup>6</sup> Data for 1908.

## TURPENTINE.

TABLE 133.—*International trade in spirits of turpentine, calendar years, 1907–1911.*

["Spirits of turpentine" includes only "spirits" or "oil" of turpentine and, for Russia, *skipidar*; it excludes crude turpentine, pitch, and, for Russia, *terpentin*. See "General note," p. 564.]

## EXPORTS.

Country.	1907	1908	1909	1910	1911
	<i>Gallons.</i>	<i>Gallons.</i>	<i>Gallons.</i>	<i>Gallons.</i>	<i>Gallons.</i>
Belgium <sup>1</sup> .....					2, 156, 527
France.....	2, 538, 689	2, 397, 686	2, 400, 228	2, 851, 038	3, 126, 215
Germany.....	349, 552	433, 235	380, 385	429, 499	419, 701
Netherlands.....	1, 675, 771	1, 851, 918	2, 068, 870	1, 812, 021	2, 288, 251
Russia.....	2, 705, 255	1, 773, 655	1, 833, 377	2, 473, 311	2, 697, 621
Spain.....	907, 429	1, 131, 140	1, 150, 493	1, 169, 615	1, 125, 831
United States.....	17, 176, 843	19, 433, 181	16, 061, 783	14, 252, 322	18, 197, 659
Other countries.....	95, 000	226, 000	444, 000	590, 000	714, 000
Total.....	25, 448, 539	27, 246, 815	24, 339, 136	23, 577, 806	30, 725, 806

## IMPORTS.

Argentina.....	521, 852	446, 962	411, 290	434, 913	617, 398
Australia.....	522, 656	395, 430	347, 110	406, 402	858, 757
Austria-Hungary.....	2, 291, 131	2, 409, 689	2, 439, 635	2, 502, 527	2, 517, 868
Belgium <sup>1</sup> .....					3, 611, 852
Canada.....	1, 028, 936	1, 031, 180	1, 141, 238	1, 044, 734	1, 123, 050
Chile.....	207, 235	118, 541	155, 340	168, 781	260, 826
Germany.....	8, 986, 011	10, 088, 770	9, 764, 051	8, 659, 883	8, 367, 039
Italy.....	921, 278	1, 020, 117	824, 643	855, 538	966, 876
Netherlands.....	3, 035, 996	3, 932, 317	2, 785, 377	2, 696, 243	3, 475, 252
New Zealand.....	145, 808	138, 807	96, 208	136, 798	240, 994
Russia.....	240, 857	238, 671	205, 105	234, 992	274, 772
Sweden.....	146, 201	148, 912	126, 289	121, 837	130, 928
Switzerland.....	404, 820	503, 873	412, 046	418, 690	440, 644
United Kingdom.....	7, 515, 293	8, 656, 464	6, 522, 833	7, 041, 316	7, 154, 047
Other countries.....	983, 000	956, 000	725, 000	861, 000	1, 131, 000
Total.....	26, 951, 074	30, 135, 733	25, 956, 166	25, 583, 662	31, 171, 301

<sup>1</sup> Not separately stated prior to 1911.<sup>2</sup> Preliminary.

INDIA RUBBER.

TABLE 134.—International trade in india rubber, calendar years, 1907–1911.

[Figures for india rubber include "india rubber," so called, and *caoutchouc, caucho, jebe* (Peru), *hule* (Mexico), *borracha, massaranduba, mangabeira, manicoba, sorva* and *seringa* (Brazil), *gomelastiek* (Dutch East Indies), *caura, sernambi* (Venezuela). See "General note," p. 564.]

EXPORTS.

Country.	1907	1908	1909	1910	1911
	<i>Pounds.</i>	<i>Pounds.</i>	<i>Pounds.</i>	<i>Pounds.</i>	<i>Pounds.</i>
Angola <sup>1</sup> .....	5,200,000	5,200,000	5,200,000	5,200,000	5,200,000
Belgian Kongo.....	10,266,212	10,052,813	8,268,606	7,532,642	7,494,461
Belgium.....	13,885,883	15,036,488	16,168,832	18,303,063	20,209,013
Bolivia.....	4,035,549	4,008,375	6,729,438	6,873,171	8,036,982
Brazil.....	80,444,966	84,229,657	86,038,347	84,980,650	78,371,605
Dutch East Indies.....	14,067,941	6,719,830	3,587,702	6,119,577	26,832,891
Ecuador.....	1,033,660	876,818	1,133,782	1,218,253	1,218,253
France.....	12,751,252	13,045,357	15,993,271	23,702,977	26,142,808
French Guinea.....	2,864,254	2,878,670	3,986,865	3,763,142	4,226,236
French Kongo.....	4,061,312	3,378,552	3,827,832	3,978,860	3,978,860
Germany.....	10,500,289	9,099,707	8,964,345	10,481,330	10,121,960
Gold Coast.....	3,549,548	1,773,248	2,764,190	3,223,265	2,668,667
Ivory Coast.....	3,024,753	2,018,624	2,737,842	3,023,878	3,023,878
Kamerun.....	3,291,051	2,677,090	3,345,778	4,324,887	15,571,222
Mexico.....	12,837,750	12,468,378	14,743,018	19,445,463	19,445,463
Netherlands.....	4,121,065	3,774,004	3,952,718	3,805,062	7,045,533
Peru.....	6,675,364	5,546,048	294,998	5,842,014	5,842,014
Senegal.....	2,293,141	1,417,115	2,790,219	1,526,624	1,526,624
Singapore.....	5,422,133	2,783,867	5,544,267	3,756,000	3,756,000
Southern Nigeria.....	2,843,823	1,222,203	1,388,009	2,634,023	2,164,286
Venezuela.....	626,259	583,403	586,970	856,652	897,411
Other countries.....	12,357,000	11,616,000	18,641,000	14,979,000	16,772,000
Total.....	216,153,205	200,406,247	216,688,029	235,570,533	250,546,187

IMPORTS.

Austria-Hungary.....	4,967,405	4,237,462	4,744,740	6,156,346	6,762,831
Belgium.....	18,292,311	17,783,302	18,854,099	23,316,174	24,657,309
Canada.....	2,777,668	1,868,569	2,769,751	2,967,430	3,700,061
France.....	24,111,666	22,097,319	25,579,092	32,080,457	39,711,019
Germany.....	34,851,419	32,497,788	34,208,999	41,237,704	44,002,498
Italy.....	2,241,637	3,298,963	3,455,490	4,142,062	5,334,912
Netherlands.....	8,142,794	6,522,620	6,364,301	7,885,995	10,279,757
Russia.....	15,036,756	16,683,536	15,826,110	16,201,141	14,894,472
United Kingdom.....	35,646,016	24,253,600	33,839,456	45,818,864	37,487,632
United States.....	68,653,291	76,289,474	93,967,414	90,139,232	82,851,725
Other countries.....	5,637,000	6,645,000	6,550,000	9,322,000	10,474,000
Total.....	220,357,963	212,177,633	246,149,452	279,267,345	280,156,202

<sup>1</sup> Estimated average annual exports.

<sup>2</sup> Preliminary.

<sup>3</sup> Year preceding.

## SILK.

TABLE 135.—*Production of raw silk in countries named, 1907–1911.*

[Estimate of the Silk Manufacturers' Association of Lyons, France.]

Country.	1907	1908	1909	1910	1911 <sup>1</sup>
Western Europe:	<i>Pounds.</i>	<i>Pounds.</i>	<i>Pounds.</i>	<i>Pounds.</i>	<i>Pounds.</i>
Italy.....	10,626,000	9,890,000	1,486,000	701,000	886,000
France.....	1,459,000	1,446,000	9,372,000	8,702,000	7,694,000
Spain.....	181,000	165,000	181,000	183,000	194,000
Austria-Hungary.....	761,000	736,000	833,000	776,000	772,000
Total.....	13,027,000	12,237,000	11,872,000	10,362,000	9,546,000
Levant and Central Asia:					
Anatolia.....	1,327,000	1,356,000	1,466,000	1,058,000	1,200,000
Syria and Cyprus.....	1,179,000	1,080,000	981,000	1,190,000	1,157,000
Other Provinces of Asiatic Turkey.....	322,000	320,000	276,000	287,000	353,000
Salonica and Adrianople.....	754,000	628,000	838,000	794,000	827,000
Balkan States.....	496,000	456,000	492,000	386,000	375,000
Greece and Crete.....	168,000	143,000	132,000	126,000	187,000
Caucasus.....	1,085,000	794,000	1,190,000	1,146,000	1,058,000
Persia and Turkestan (exports).....	1,340,000	1,160,000	1,323,000	1,186,000	1,329,000
Total.....	6,671,000	5,937,000	6,698,000	6,173,000	6,526,000
Far East:					
China—					
Exports from Shanghai.....	9,160,000	12,430,000	11,431,000	11,448,000	13,095,000
Exports from Canton.....	4,960,000	5,243,000	5,059,000	5,814,000	3,814,000
Japan—					
Exports from Yokohama.....	14,044,000	16,689,000	18,457,000	19,698,000	20,657,000
British India—					
Exports from Calcutta and Bombay.....	772,000	551,000	518,000	507,000	529,000
Total.....	28,936,000	34,913,000	35,465,000	37,467,000	38,095,000
Grand total.....	48,634,000	53,087,000	54,035,000	54,002,000	54,167,000

<sup>1</sup> Preliminary.TABLE 136.—*Total production of raw silk in countries named in Table 135, 1900–1911.*

Year.	Production.	Year.	Production.	Year.	Production.
	<i>Pounds.</i>		<i>Pounds.</i>		<i>Pounds.</i>
1900.....	40,724,000	1904.....	45,195,000	1908.....	53,087,000
1901.....	42,393,000	1905.....	41,513,000	1909.....	54,035,000
1902.....	41,368,000	1906.....	46,106,000	1910.....	54,002,000
1903.....	39,981,000	1907.....	48,634,000	1911 <sup>1</sup> .....	54,167,000

<sup>1</sup> Preliminary.

WOOD PULP.

TABLE 137.—*International trade in wood pulp, calendar years, 1907-1911.*

†All kinds of pulp from wood have been taken for this item, but no pulp made from other fibrous substances. See "General note," p. 564.]

EXPORTS.

Country.	1907	1908	1909	1910	1911
	<i>Pounds.</i>	<i>Pounds.</i>	<i>Pounds.</i>	<i>Pounds.</i>	<i>Pounds.</i>
Austria-Hungary.....	187,834,786	177,782,251	173,668,467	194,807,715	218,780,756
Belgium.....	72,942,604	54,463,236	59,705,365	82,609,340	95,275,940
Canada.....	1 483,000,000	1 480,000,000	561,487,800	657,955,900	519,027,600
Finland.....	133,408,845	140,859,363	157,561,012	191,271,652	251,911,906
Germany.....	211,883,665	281,359,650	341,335,793	388,760,487	378,484,185
Norway.....	1,227,091,427	1,310,889,243	1,328,893,206	1,401,685,165	1,369,248,047
Russia.....	61,580,233	47,652,934	66,965,337	63,986,501	55,260,132
Sweden.....	1,170,305,195	1,242,837,820	1,242,456,239	1,682,832,631	1,868,461,199
Switzerland.....	13,066,003	12,338,044	11,168,724	13,013,313	13,407,716
United States.....	24,839,012	22,595,379	17,905,481	16,721,779	18,988,131
Other countries.....	14,580,000	9,173,000	7,225,000	7,979,000	2 8,458,000
Total.....	3,600,531,770	3,779,950,920	3,966,372,424	4,701,623,483	4,797,303,612

IMPORTS.

Argentina.....	40,845,513	39,930,438	33,847,259	58,283,142	53,447,039
Austria-Hungary.....	4,304,041	5,601,668	7,675,094	11,400,428	16,710,207
Belgium.....	243,153,802	265,425,463	258,171,760	282,016,826	301,781,340
Denmark.....	80,112,298	75,009,310	100,035,930	100,798,280	104,576,524
France.....	630,964,236	692,394,579	640,890,227	789,105,265	2 801,927,439
Germany.....	116,994,374	99,260,792	90,295,125	88,516,233	137,682,561
Italy.....	126,905,594	135,942,250	145,528,953	158,366,559	175,641,805
Japan.....	35,477,491	40,754,443	38,311,700	79,726,177	71,020,549
Portugal.....	13,768,353	14,867,551	16,274,351	17,389,931	3 17,389,931
Russia.....	45,478,955	49,052,161	49,932,916	53,038,292	59,452,105
Spain.....	82,575,129	79,953,413	69,243,596	70,047,697	89,508,197
Sweden.....	6,691,869	6,448,345	6,685,152	8,205,120	11,568,127
Switzerland.....	19,232,489	20,913,938	19,705,376	17,125,553	17,893,135
United Kingdom.....	1,484,703,360	1,662,662,400	1,661,959,040	1,892,571,520	1,716,153,080
United States.....	593,555,200	500,969,689	735,300,119	1,013,550,715	1,124,650,568
Other countries.....	11,656,000	10,498,000	42,951,600	56,532,000	2 65,894,000
Total.....	3,536,419,704	3,699,984,440	3,916,807,598	4,696,673,738	4,765,281,667

1 Unofficial estimate.

2 Preliminary.

3 Year preceding.

## FARM ANIMALS AND THEIR PRODUCTS.

TABLE 138.—*Live stock of countries named.*

[Africa incompletely represented, through lack of statistics for large areas. Number of animals in China, Persia, Afghanistan, Korea, Bolivia, Ecuador, and several less important countries unknown. For Brazil number of cattle alone estimated, but roughly. In general, statistics of cattle, horses, sheep, and swine much more complete than those of other animals, as statements for the world.]

Country.	Year.	Cattle.		Horses.	Mules.	Sheep.	Swine.
		Total.	Dairy cows.				
<b>NORTH AMERICA.</b>							
<b>United States:</b>							
Contiguous—							
On farms.....	1913	56,507,000	20,497,000	20,567,000	4,386,000	51,482,000	61,178,000
Not on farms....	1910	1,878,782	1,170,338	3,182,789	270,371	390,887	1,287,960
Noncontiguous—							
Alaska.....	1910	1,167	459	2,312	214	199	379
Hawaii.....	1910	149,071	8,482	27,564	9,375	76,722	30,844
Porto Rico.....	1899	260,225	73,372	58,664	6,985	6,363	66,180
Total United States (except Philippine Islands).....		58,796,245	21,749,651	23,838,329	4,672,945	51,956,171	62,563,363
Bermuda.....	1907	1,516	.....	1,082	.....	.....	.....
<b>Canada:</b>							
Prince Edward Island.....	1912	106,100	52,600	33,700	.....	104,500	41,500
Nova Scotia.....	1912	331,600	152,600	69,400	.....	343,200	67,600
New Brunswick.....	1912	235,500	125,500	66,800	.....	179,300	91,400
Quebec.....	1912	1,483,200	875,800	369,500	.....	519,800	656,900
Ontario.....	1912	2,697,000	1,235,000	784,800	.....	838,700	1,335,000
Manitoba.....	1912	438,900	158,900	263,800	.....	32,300	132,100
Saskatchewan.....	1912	599,800	146,500	397,300	.....	111,800	156,700
Alberta.....	1912	1,091,600	143,200	351,500	.....	181,000	175,200
British Columbia.....	1901	125,002	24,535	37,325	.....	33,350	41,410
Total Canada.....		7,108,702	2,914,635	2,374,125	.....	2,393,950	2,697,819
<b>Central America:</b>							
Costa Rica.....	1910	333,017	*125,439	60,114	3,185	604	69,712
Guatemala.....	1898	196,768	.....	50,343	.....	77,593	29,784
Honduras.....	1909	666,215	.....	64,122	13,434	24,052	145,352
Nicaragua.....	1908	252,070	.....	28,276	6,078	338	11,591
Panama.....	1907	65,000	.....	17,000	1,500	.....	28,000
Salvador.....	1908	284,013	.....	74,336	.....	21,457	422,960
Mexico.....	1902	5,142,457	.....	859,217	334,435	3,424,430	616,130
Miquelon <sup>4</sup> .....	1911	20	.....	32	.....	160	.....
Newfoundland.....	1911	30,472	.....	13,694	.....	97,597	26,952
St. Pierre <sup>4</sup> .....	1911	.....	.....	8	.....	.....	.....
<b>West Indies:</b>							
<b>British—</b>							
Bahamas.....	1911	1,734	.....	1,141	.....	10,412	.....
Barbados.....	1910	.....	.....	*2,541	3,860	.....	.....
Dominica.....	1911	.....	.....	700	.....	.....	.....
Grenada.....	1910	5,109	.....	1,493	.....	1,975	.....
Jamaica.....	1911	109,168	.....	51,150	.....	12,359	31,116
Montserrat.....	1911	.....	.....	241	.....	.....	.....
Trinidad and Tobago.....	1911	14,025	.....	4,873	.....	1,742	7,436
Turks and Caicos Islands.....	1911	500	.....	75	.....	50	250
Virgin Islands.....	1911	.....	.....	249	.....	.....	.....
Cuba.....	1910	3,074,509	.....	555,423	58,957	*9,982	*358,868
Dutch West Indies.....	1910	3,732	.....	777	171	24,345	6,352
Guadeloupe <sup>4</sup> .....	1911	2,500	.....	.....	.....	.....	.....
Martinique <sup>4</sup> .....	1911	2,000	.....	.....	.....	.....	.....
Total.....		76,098,772	( <sup>6</sup> )	27,999,341	5,094,565	58,057,217	67,015,718

<sup>1</sup> Including mules and asses.

<sup>2</sup> Cows.

<sup>3</sup> Data for 1911.

<sup>4</sup> Data furnished by the American Consul General at Paris, France, from preliminary official returns.

<sup>5</sup> Census, 1899.

<sup>6</sup> Total omitted because of too few reports from individual countries.

TABLE 138.—Live stock of countries named—Continued.

Country.	Year.	Cattle.		Horses.	Mules.	Sheep.	Swine.
		Total.	Dairy cows.				
<b>SOUTH AMERICA.</b>							
Argentina.....	1912	<i>Number.</i> 28,786,168	<i>Number.</i> .....	<i>Number.</i> 8,894,031	<i>Number.</i> 534,813	<i>Number.</i> 80,401,486	<i>Number.</i> 2,900,000
Brazil.....	.....	25,000,000	.....	.....	.....	.....	.....
British Guiana.....	1911	81,469	.....	2,655	.....	19,160	17,000
Chile.....	1911	1,640,322	938,619	352,108	30,335	3,537,728	166,050
Colombia.....	.....	2,800,000	.....	341,000	257,000	746,000	2,300,000
Dutch Guiana.....	1909	6,990	.....	270	257	109	3,726
Falkland Islands.....	1911	7,859	.....	3,554	.....	706,170	60
French Guiana <sup>1</sup> .....	1911	4,000	.....	.....	.....	.....	.....
Paraguay <sup>2</sup> .....	1908	5,500,000	.....	182,790	7,626	214,060	23,900
Uruguay.....	1908	8,192,602	.....	556,307	17,671	26,286,296	180,099
Venezuela.....	1899	2,004,257	.....	191,079	89,186	176,658	1,618,214
Total.....	.....	74,023,658	( <sup>3</sup> )	10,523,794	936,888	112,087,677	7,202,049
<b>EUROPE.</b>							
<b>Austria-Hungary:</b>							
Austria.....	1911	9,160,009	4,901,886	1,802,848	20,607	2,428,101	6,432,080
Hungary.....	1911	7,319,121	.....	2,351,451	21,949	8,548,204	7,580,446
Bosnia-Herzegovina	1910	1,308,753	.....	221,896	46,721	2,498,854	527,223
Total, Austria-Hungary.....	.....	17,787,883	( <sup>3</sup> )	4,376,225	49,277	13,475,159	14,539,749
Belgium.....	1911 <sup>4</sup>	1,823,000	492,534	255,229	76,915	725,722	1,136,000
Bulgaria.....	1905	1,695,533	493,451	538,271	11,947	8,130,997	465,333
Denmark.....	1909	2,253,982	1,281,974	535,018	.....	726,879	1,487,822
Faroe Islands.....	1909	4,093	.....	615	.....	99,900	58
Finland.....	1907	1,491,264	1,113,633	327,817	.....	904,447	221,072
France.....	1911	14,552,430	7,606,670	3,236,110	194,040	18,425,330	6,719,570
Germany.....	1912	20,158,738	.....	4,516,297	1,746	5,787,848	21,888,073
Gibraltar.....	1911	348	.....	295	.....	.....	.....
Greece.....	1902	406,744	.....	159,068	88,869	4,568,158	79,716
Iceland.....	1910	26,338	.....	44,815	.....	578,634	.....
Italy.....	1908	6,198,861	.....	955,878	388,337	11,162,926	2,507,798
Luxemburg.....	1910	94,183	56,941	18,625	29	5,580	128,035
Malta.....	1912	5,724	.....	3,269	2,890	16,424	3,892
Montenegro.....	.....	60,000	20,000	3,000	.....	400,000	8,000
Netherlands.....	1910	2,026,943	1,068,361	327,377	.....	889,036	1,259,844
Norway.....	1908 <sup>5</sup>	1,094,101	727,898	172,468	.....	1,363,488	318,556
Portugal.....	1906	703,198	.....	87,765	57,647	3,072,988	1,110,957
Roumania.....	1908	2,585,000	.....	807,704	.....	5,104,000	1,709,205
<b>Russia:</b>							
Russia proper.....	1909	30,735,000	.....	20,961,000	.....	140,149,000	9,743,000
Poland.....	1909	2,268,000	.....	1,243,000	.....	11,248,000	608,000
Northern Caucasia..	1909	2,778,000	.....	1,344,000	.....	11,592,000	684,000
Total European Russia.....	1909	35,781,000	.....	23,548,000	.....	146,989,000	11,035,000
Servia.....	1911 <sup>6</sup>	957,918	.....	152,617	349	3,808,815	863,544
Spain.....	1912	2,541,112	.....	546,035	904,725	15,725,882	2,472,416
Sweden.....	1910	2,747,526	1,861,219	586,835	.....	1,003,921	957,128
Switzerland.....	1911	1,443,371	.....	143,723	.....	3,072,988	569,253
Turkey, European <sup>12</sup> .....	1908	1,471,801	.....	254,964	65,381	6,912,568	203,633
<b>United Kingdom:</b>							
England and Wales.....	1912	5,841,908	2,348,062	1,406,099	.....	18,053,584	2,496,358
Scotland.....	1912	1,178,936	435,323	204,792	.....	6,991,677	159,391
Ireland.....	1912	4,848,498	1,508,662	617,532	30,911	3,828,829	1,415,119
Isle of Man and Channel Islands..	1911	40,127	17,333	9,891	.....	77,379	12,740
Total, United Kingdom.....	.....	11,909,469	4,309,380	2,238,314	30,911	28,951,469	4,083,608
Total.....	.....	129,820,560	( <sup>3</sup> )	43,836,334	1,803,063	176,523,898	73,745,262

<sup>1</sup> Data furnished by the American Consul General at Paris, France, from preliminary official returns.  
<sup>2</sup> Unofficial estimate.  
<sup>3</sup> Total omitted because of too few reports for individual countries.  
<sup>4</sup> Including asses.  
<sup>5</sup> On Dec. 31 of preceding year.  
<sup>6</sup> Dairy cows 2 years old and over.  
<sup>7</sup> Data for 1895.

<sup>8</sup> Cows.  
<sup>9</sup> Data for 1911.  
<sup>10</sup> Including cows kept for breeding purposes.  
<sup>11</sup> Including goats.  
<sup>12</sup> Not including vilayets of Scutari and Constantinople.  
<sup>13</sup> Cows and heifers in milk and with calf.  
<sup>14</sup> Used for agriculture and unbroken.



TABLE 138.—Live stock of countries named—Continued.

Country.	Year.	Cattle.		Horses.	Mules.	Sheep.	Swine.
		Total.	Dairy cows.				
ASIA.							
British India:		<i>Number.</i>	<i>Number.</i>	<i>Number.</i>	<i>Number.</i>	<i>Number.</i>	<i>Number.</i>
British Provinces...	1911	1 103,594,649	31,753,081	1,564,935	<sup>2</sup> 112,697	23,280,662	
Native States <sup>2</sup> .....	1910	1 10,396,430	3,504,378	140,538		3,835,674	
Total British India.....		1 113,991,079	35,257,459	1,705,473		27,116,336	
Ceylon.....	1911	1,620,709		5,203		94,963	92,489
Cochin China <sup>4</sup> .....	1911	310,045		10,948	3	112	26,479
Cyprus.....	1912	60,353		<sup>5</sup> 69,832		<sup>6</sup> 259,605	35,883
Dutch East Indies:							
Java and Madura...	1905	2,654,461		363,974			
Other.....	1905	449,268		118,645			
Total Dutch East Indies.....	1905	3,103,729		482,619			
Formosa.....	1910 <sup>7</sup>	176,181		198			1,308,264
French India <sup>4</sup> .....	1911	44,330				9,858	
Hongkong.....	1911	1,832		218			
Japan.....	1911 <sup>7</sup>	1,384,183		1,564,643		3,357	279,161
Philippine Islands.....	1911	242,398		215,674		88,760	2,066,665
Russia:							
Central Asia.....	1909	4,545,000		3,985,000		<sup>8</sup> 21,456,000	123,000
Siberia.....	1909	5,184,000		4,179,000		<sup>8</sup> 5,439,000	1,191,000
Transcaucasia.....	1909	2,981,000		402,000		5,679,000	302,000
Other.....	1903	2,343,000		1,624,000		5,443,000	186,400
Total Asiatic Russia.....		15,053,000		10,190,000		38,017,000	1,802,400
Siam.....	1904	2,209,522		71,624			
Straits Settlements and Labuan.....	1911	44,286		2,950			141,076
Turkey, Asiatic.....		3,000,000		800,000		45,000,000	
Total.....		141,241,647	( <sup>9</sup> )	15,119,382	112,700	110,589,931	5,752,297
AFRICA.							
Algeria.....	1911	1,113,952		226,764	192,484	8,528,610	110,012
Basutoland.....	1911	437,411		87,997		1,368,999	476
Bechuanaland.....	1911	323,911		1,632		<sup>8</sup> 358,336	
British East Africa.....	1912	775,000		950		6,500,000	3,000
Dahomey <sup>4</sup> .....	1911	118,556		994		196,043	
Egypt.....	1909	725,116		<sup>10</sup> 54,666	<sup>11</sup> 10,000		
Eritrea.....	1905	250,891		1,027	28,765	383,576	
French Guinea <sup>4</sup> .....	1911	382,228		3,074	11	128,112	
Gabon <sup>4</sup> .....	1911	119		17		10,115	
Gambia.....	1907	82,871		3,851			
German East Africa.....	1905	523,052		73	79	1,560,000	1,447
German South west Africa.....	1909	96,112		8,271	4,636	300,722	2,917
Ivory Coast <sup>4</sup> .....	1911	91,580				91,768	525
Madagascar.....	1911	5,330,209	1,118,162	1,958	1,358	251,587	543,168
Mauritius.....	1911	<sup>11</sup> 17,350		560	<sup>12</sup> 86	1,366	6,023
Mayotte and dependencies <sup>4</sup> .....	1911	33,500		43	21	170	
Nyasaland Protectorate.....	1912	59,758		266		22,131	18,640
Reunion <sup>4</sup> .....	1911	4,507		264	974	1,523	550
Rhodesia:							
Northeastern.....	1910	9,791					
Northwestern.....	1910	24,433					
Southern.....	1910	371,000				231,736	

<sup>1</sup> Including buffalo calves.<sup>2</sup> Of which 31,936 in Bengal includes donkeys.<sup>3</sup> Data only for those States for which official figures are available.<sup>4</sup> Data furnished by the American Consul General at Paris, France, for preliminary official returns.<sup>5</sup> Including mules and asses.<sup>6</sup> Not less than 1 year old; 30 per cent may be added for those less than 1 year old.<sup>7</sup> On Dec. 31 of preceding year.<sup>8</sup> Including goats.<sup>9</sup> Total omitted because of too few reports for individual countries.<sup>10</sup> Data for 1907.<sup>11</sup> On sugar estates only.<sup>12</sup> Data for 1910.

TABLE 138.—Live stock of countries named—Continued.

Country.	Year.	Cattle.		Horses.	Mules.	Sheep.	Swine.
		Total.	Dairy cows.				
<b>AFRICA—continued.</b>							
		<i>Number.</i>	<i>Number.</i>	<i>Number.</i>	<i>Number.</i>	<i>Number.</i>	<i>Number.</i>
St. Helena.....	1911	1,271	.....	152	.....	4,446	282
Senegal <sup>1</sup> .....	1911	665,016	.....	35,959	16	206,060	.....
Seychelles.....	1911	1,000	.....	150	.....	200	6,000
Sierra Leone.....	1910	1,687	.....	6	.....	674	10
Somali Coast.....	1911	11	.....	3	.....	6	.....
Somaliland (Italian).....	1910	885,000	.....	.....	.....	175,000	.....
Southern Nigeria (Lagos).....	1902	1,522	.....	108	.....	1,610	2,426
Sudan (Anglo-Egyptian) <sup>2</sup> .....	1908	340,372	.....	8,251	.....	952,950	.....
Swaziland.....	1911	57,601	.....	541	.....	<sup>3</sup> 163,593	8,994
Tunis.....	1912	191,450	.....	39,441	13,259	686,730	17,898
Uganda Protectorate.....	1911	758,700	.....	6	.....	864,000	<sup>4</sup> 600
<b>Union of South Africa:</b>							
Cape of Good Hope.....	1911	2,715,330	.....	333,962	.....	17,134,513	505,730
Natal.....	1911	456,087	.....	75,567	.....	1,519,258	110,332
Orange River Colony.....	1911	1,286,234	.....	220,725	.....	8,587,638	162,656
Transvaal.....	1911	1,339,298	.....	89,160	<sup>6</sup> 16,134	3,415,250	302,882
Total Union of South Africa.....	1911	5,796,949	.....	719,414	.....	30,656,650	1,081,600
Total.....		19,471,926	( <sup>6</sup> )	1,196,438	267,853	53,646,662	1,804,568
<b>OCEANIA.</b>							
<b>Australia:</b>							
Queensland.....	1911 <sup>7</sup>	5,073,201	.....	618,954	.....	26,740,981	173,902
New South Wales.....	1911 <sup>7</sup>	3,184,039	.....	688,514	.....	44,892,117	371,093
Victoria.....	1911 <sup>7</sup>	1,647,127	.....	507,813	.....	13,857,804	348,069
South Australia.....	1911 <sup>7</sup>	393,566	.....	259,719	.....	6,171,907	93,130
Western Australia.....	1911 <sup>7</sup>	843,638	.....	140,277	.....	5,411,542	55,635
Tasmania.....	1911 <sup>7</sup>	217,406	.....	41,853	.....	1,823,017	67,392
Total Australia.....	1911 <sup>7</sup>	11,358,977	.....	2,257,130	.....	92,897,368	1,109,221
Fiji.....	1911	45,000	.....	6,228	.....	4,561	3,120
New Caledonia <sup>1</sup> .....	1911	128,500	.....	3,250	91	6,230	.....
New Zealand.....	1911	2,020,171	633,733	404,284	404	23,996,126	348,754
Territory of Papua.....	1911	1,149	.....	339	.....	177	30
Total.....		13,553,797	( <sup>6</sup> )	2,671,231	495	116,904,462	1,461,125
Grand total.....		454,210,360	( <sup>6</sup> )	101,346,520	8,215,564	627,814,847	156,981,019

<sup>1</sup> Data furnished by the American Consul General at Paris, France, from preliminary official returns.

<sup>2</sup> Animals assessed for tribute.

<sup>3</sup> Including goats.

<sup>4</sup> Data for 1909.

<sup>5</sup> Data for 1910.

<sup>6</sup> Total omitted because of too few reports from individual countries.

<sup>7</sup> Year ending Mar. 31.

TABLE 138.—*Live stock of countries named—Continued.*

Country.	Year.	Asses.	Buffaloes.	Camels.	Goats.	Reindeer.
<b>NORTH AMERICA.</b>						
United States:						
Contiguous—		<i>Number.</i>	<i>Number.</i>	<i>Number.</i>	<i>Number.</i>	<i>Number.</i>
On farms.....	1910	105,698			2,915,125	
Not on farms.....	1910	16,502			114,670	
Noncontiguous—						
Alaska.....	1910	3			36	22,107
Hawaii.....	1910	2,847	399		5,110	
Porto Rico.....	1899	1,085			15,991	
Total United States (except Philippine Islands).....		126,135	399		3,050,932	22,107
Central America:						
Costa Rica.....	1910	149			776	
Honduras.....	1909	2,373				
Nicaragua.....	1908	1,343			979	
Panama.....	1907	47			3,000	
Mexico.....	1902	287,991			4,206,011	
St. Pierre <sup>1</sup> .....	1911	2				
Newfoundland.....	1901				17,355	450
Miquelon <sup>1</sup> .....	1911	1				
West Indies:						
British—						
Bahamas.....	1910				3,535	
Barbados.....	1910	4,425				
Jamaica.....	1910				17,050	
Trinidad and To- bago.....	1911 <sup>2</sup>				7,000	
Cuba.....	1910	3,340			18,564	
Dutch.....	1910	6,661			59,284	
Total.....		432,467	399		7,384,486	22,557
<b>SOUTH AMERICA.</b>						
Argentina.....	1912	319,315			4,301,955	
British Guiana.....	1910				10,300	
Chile.....	1911	32,642			210,143	
Colombia.....					361,000	
Dutch Guiana.....	1909	321			2,686	
Paraguay.....	1908				32,334	
Uruguay.....	1908	4,428			19,951	
Venezuela.....	1899	312,810			1,667,272	
Total.....		669,516			6,605,641	
<b>EUROPE.</b>						
Austria-Hungary:						
Austria.....	1911	52,801			1,256,778	
Hungary.....	1911				426,981	
Bosnia-Herzegovina.....	1910		979		1,392,565	
Total Austria-Hun- gary.....		52,801	979		3,076,324	
Belgium.....	1905 <sup>3</sup>				257,669	
Bulgaria.....	1905	124,080	476,872		1,384,116	
Denmark.....	1909	167			40,257	
Faroe Islands.....	1909				13	
Finland.....	1907				6,279	133,749
France.....	1912 <sup>2</sup>	300,950			1,424,180	
Germany.....	1912	11,086			3,383,971	
Greece.....	1902	141,179			3,339,409	
Iceland.....	1910				660	
Italy.....	1908	849,723	19,362		2,714,378	
Luxemburg.....	1910				10,325	
Malta.....	1911	2,909			17,587	
Montenegro.....					100,000	
Netherlands.....	1910				224,231	
Norway.....	1907 <sup>2</sup>				206,442	142,623
Portugal.....	1906	144,089			1,034,218	
Roumania.....	1908				297,000	

<sup>1</sup> Data furnished by the American Consul General at Paris, France, from preliminary official returns.

<sup>2</sup> Dec. 31 of preceding year.

<sup>3</sup> Census 1899.

TABLE 138.—*Live stock of countries named*—Continued.

Country.	Year.	Asses.	Buffaloes.	Camels.	Goats.	Reindeer.
Russia:		<i>Number.</i>	<i>Number.</i>	<i>Number.</i>	<i>Number.</i>	<i>Number.</i>
Russia proper.....	1905			224,500		347,000
Poland.....				1,000		
<b>Total European Russia.....</b>				<b>225,500</b>		<b>347,000</b>
Servia.....	1911 <sup>1</sup>	871	7,290		627,427	
Spain.....	1912	836,741		3,398	3,369,624	
Sweden.....	1910				69,179	<sup>2</sup> 237,253
Switzerland.....	1911				339,997	
Turkey, European <sup>3</sup> .....	1908	224,949	156,858	2,801	3,520,873	
United Kingdom:						
Ireland.....	1912	243,437			<sup>4</sup> 258,474	
<b>Total.....</b>		<b>2,992,982</b>	<b>661,361</b>	<b>231,699</b>	<b>25,793,133</b>	<b>860,625</b>
<b>ASIA.</b>						
British India:						
British Provinces.....	1911	1,342,274	17,063,432	446,634	30,900,309	
Native States <sup>5</sup> .....	1910	<sup>6</sup> 155,346	1,558,827	54,348	3,293,797	
<b>Total British India.....</b>		<b>1,497,620</b>	<b>18,622,259</b>	<b>500,982</b>	<b>34,194,106</b>	
Ceylon.....	1909		579,069		170,645	
Cochin China <sup>6</sup> .....	1911				2,237	
Cyprus.....	1911			1,191	<sup>8</sup> 270,981	
Dutch East Indies:						
Java and Madura.....	1905		2,186,993			
Other.....	1905		446,540			
<b>Total Dutch East Indies.....</b>	1905		<b>2,633,533</b>			
Formosa.....	1910 <sup>1</sup>		304,067		136,883	
French India <sup>7</sup> .....	1911				23,701	
Hongkong.....	1909				194	
Japan.....	1911 <sup>1</sup>				91,730	
Philippine Islands <sup>9</sup> .....	1911		713,121		407,087	
Russia:						
Central Asia (4 provinces).....	1903			365,000		
Siberia (4 provinces).....	1903			500		33,700
Transcaucasia.....	1902	122,312	338,042	17,122	745,086	
Other.....	1903	58,500		296,000	802,000	20,000
<b>Total Asiatic Russia.....</b>		<b>180,812</b>	<b>338,042</b>	<b>678,622</b>	<b>1,547,086</b>	<b>58,700</b>
Siam <sup>10</sup> .....	1904		2,288,956			
Turkey, Asiatic.....		2,500,000			9,000,000	
<b>Total.....</b>		<b>4,178,432</b>	<b>25,479,047</b>	<b>1,180,795</b>	<b>45,844,650</b>	<b>58,700</b>

<sup>1</sup> Dec. 31 of preceding year.

<sup>2</sup> Data for 1909.

<sup>3</sup> Does not include vilayets of Scutari and Constantinople.

<sup>4</sup> Data for 1911.

<sup>5</sup> Data only for those States for which official figures are available.

<sup>6</sup> Including mules.

<sup>7</sup> Data furnished by the American Consul General at Paris, France, from preliminary official returns.

<sup>8</sup> Not less than 1 year old; 30 per cent may be added for those less than 1 year old.

<sup>9</sup> Ten per cent may be added to cover incompleteness of returns.

<sup>10</sup> Number of domesticated elephants reported as 4,072.

TABLE 138.—*Live stock of countries named*—Continued.

Country.	Year.	Asses.	Buffaloes.	Camels.	Goats.	Reindeer.
AFRICA.						
		<i>Number.</i>	<i>Number.</i>	<i>Number.</i>	<i>Number.</i>	<i>Number.</i>
Algeria.....	1912	279,315			3,861,847	
Basutoland.....	1904	10			1,625	
Bechuanaland.....	1910	2,590				
British East Africa.....	1911				4,000,000	
Dahomey <sup>1</sup> .....	1911	262			137,220	
Egypt.....	1900	120,000	2 728,284	40,000		
Eritrea.....	1905			46,853	352,556	
French Guinea <sup>1</sup> .....	1911	616			137,602	
Gabon <sup>1</sup> .....	1911	12			44,532	
German East Africa.....	1905	8,777		24	1,820,000	
German Southwest Africa.....	1909	5,189		240	242,073	
Ivory Coast <sup>1</sup> .....	1911	407			142,286	
Madagascar <sup>1</sup> .....	1911	440			96,799	
Mauritius <sup>2</sup> .....	1910				4,634	
Mayotte and dependencies <sup>1</sup> .....	1911	98			26,850	
Nyasaland Protectorate.....	1911				111,877	
Reunion <sup>1</sup> .....	1911	351			4,177	
Rhodesia:						
Southern.....	1910				628,000	
St. Helena.....	1901	774			1,001	
Senegal <sup>1</sup> .....	1911	39,970		12,487	427,835	
Seychelles.....	1909				500	
Somali Coast.....	1911	1		2	5	
Southern Nigeria:						
Colony (Lagos).....	1902	19,289			2,600	
Sudan (Anglo-Egyptian).....	1908			123,705	846,544	
Swaziland.....	1911				80,000	
Tunis.....	1912	80,951		110,707	468,828	
Union of South Africa:						
Cape of Good Hope.....	1904	100,470			4 8,275,120	
Natal.....	1909	40,330			910,848	
Orange River Colony.....	1908	5,323			1,251,308	
Transvaal.....	1910	63,983			1,508,982	
Total Union of South Africa.....		180,106			11,946,258	
Total.....		730,158	728,284	( <sup>5</sup> )	25,385,599	
OCEANIA.						
Australia:						
New South Wales.....	1905			853	37,716	
South Australia.....	1905				26,948	
Western Australia.....	1910	1,858		3,257	31,988	
Tasmania.....	1911				2,118	
Total Australia.....		1,858		( <sup>5</sup> )	98,770	
Fiji.....	1911				15,007	
New Caledonia <sup>1</sup> .....	1911	102			5,935	
New Zealand.....	1891				9,055	
Territory of Papua.....	1910				557	
Total.....		1,960		( <sup>5</sup> )	129,324	
Grand total.....		9,014,515	26,869,091	( <sup>5</sup> )	111,142,833	941,882

<sup>1</sup> Data furnished by the American Consul General at Paris, France, from preliminary official returns.

<sup>2</sup> Data for 1909.

<sup>3</sup> On sugar estates only.

<sup>4</sup> Census 1910.

<sup>5</sup> Total omitted because of too few reports from individual countries.

TABLE 139.—*International trade in hides and skins, calendar years, 1907–1911.*

[This table gives the classification as found in the original returns, and the summary statements for "All countries" represent the total for each class only so far as it is disclosed in the original returns. The following kinds are included: Alligator, buffalo, calf, camel, cattle, deer, goat, and kid, horse and colt, kangaroo, mule and ass, sheep and lamb, and all other kinds except furs, bird skins, sheep skins with wool on, skins of rabbits and hares, and tanned or partly tanned hides and skins. See "General note," p. 564.]

EXPORTS.

Country and classification.	1907	1908	1909	1910	1911
<b>Argentina:</b>	<i>Pounds.</i>	<i>Pounds.</i>	<i>Pounds.</i>	<i>Pounds.</i>	<i>Pounds.</i>
Cattle, dried.....	45,754,268	64,790,989	80,161,462	65,794,651	} 232,830,414
Cattle, salted.....	74,118,652	77,440,984	116,224,307	134,545,252	
Goat.....	2,061,980	5,089,780	5,361,735	3,745,355	} 14,308,723
Horse, dried.....	2,214,653	2,577,133	5,763,329	4,314,146	
Horse, salted.....	488,092	358,624	466,423	287,427	} 15,254,060
Kid.....	871,022	677,092	1,233,604	1,141,593	
Sheep and lamb.....	54,449,861	61,633,449	80,202,859	77,759,741	} 11,047,604
<b>Austria-Hungary:</b>					} 73,304,324
Calf, dried.....	4,249,807	4,709,246	4,137,814	2,658,968	3,484,591
Calf, wet.....	11,649,988	18,618,288	23,128,018	20,054,805	18,334,997
Cattle, dried.....	6,570,149	7,044,138	7,383,646	6,808,687	6,352,334
Cattle, wet.....	11,133,450	18,017,094	38,838,438	28,292,073	24,100,246
Goat.....	2,346,797	2,609,365	2,374,134	2,145,737	2,135,816
Horse, dried.....	777,562	1,505,742	1,722,013	1,395,291	1,106,489
Horse, wet.....	2,417,123	2,602,089	3,907,433	4,487,904	3,900,819
Kid.....	830,032	1,310,635	1,282,416	978,842	1,077,608
Lamb.....	2,358,261	3,113,557	3,461,222	3,956,596	3,176,167
Sheep.....	3,887,592	3,217,834	4,014,136	3,707,476	2,712,760
Hides and skins, unclassified.....	1,263,236	1,195,114	1,162,045	1,205,034	1,388,678
<b>Belgium:</b>					
Hides and skins, unclassified.....	97,432,789	113,410,841	108,875,306	111,995,036	124,658,505
<b>Brazil:</b>					
Deer.....	215,634	251,360	235,773	( <sup>2</sup> )	( <sup>2</sup> )
Goat.....	4,998,161	5,685,558	6,407,132	15,943,564	16,168,270
Hides, dried, not elsewhere specified.....	15,235,096	15,642,781	22,908,552	} 175,086,086	} 170,396,621
Hides, salted, not elsewhere specified.....	54,148,766	51,398,772	55,965,543		
Horse.....	1,162	2,802	9,641	( <sup>2</sup> )	( <sup>2</sup> )
Lamb.....	23,139	207,153	.....	( <sup>2</sup> )	( <sup>2</sup> )
Sheep.....	1,076,916	1,675,324	1,898,650	( <sup>2</sup> )	( <sup>2</sup> )
Hides and skins, unclassified.....	60,503	35,344	50,210	( <sup>2</sup> )	( <sup>2</sup> )
<b>British India:</b>					
Hides, unclassified.....	89,685,904	80,079,330	87,856,048	94,301,200	101,400,432
Goat.....	32,639,040	41,339,200	66,858,400	55,752,256	55,006,112
Skins, unclassified.....	4,320,624	2,115,792	3,794,336	4,840,654	5,067,426
<b>British South Africa:</b>					
Calf.....	47,046	16,419	163,352	.....	.....
Cattle.....	7,423,557	9,357,295	11,652,984	13,353,506	13,298,186
Goat.....	6,611,384	6,920,990	8,157,675	7,286,171	7,469,316
Sheep.....	17,817,237	19,302,241	23,780,392	24,681,194	24,076,978
<b>Canada:</b>					
Sheep <sup>3</sup> .....	293,418	37,292	413,340	84,382	128,687
Hides and skins, not elsewhere specified <sup>4</sup> .....	33,000,000	42,000,000	43,600,000	38,000,000	37,000,000
<b>China:</b>					
Buffalo.....	37,367,600	31,871,733	40,011,867	49,934,400	40,331,067
Horse.....	52,133	598,267	144,000	176,400	223,467
Goat.....	24,470,222	18,337,889	23,692,398	27,650,109	24,047,388
Sheep.....	1,516,130	582,110	1,206,858	1,026,898	565,120
<b>Chosen (Korea):</b>					
Cattle.....	2,423,600	2,638,704	4,507,979	5,482,431	5,632,635
Skins, unclassified.....	200,011	.....	.....	.....	.....
<b>Cuba:</b>					
Cattle.....	4,437,849	9,753,283	11,391,221	16,044,213	16,044,213
Hides and skins, unclassified.....	3,370,215	35,270	464,778	383,780	383,780
<b>Denmark:</b>					
Hides and skins, unclassified.....	16,509,684	19,318,237	20,491,426	23,001,032	21,278,578
<b>Dutch East Indies:</b>					
Hides and skins, unclassified.....	15,796,601	15,317,391	15,683,561	17,498,457	17,257,038
<b>Egypt:</b>					
Cattle and camel.....	4,943,959	5,031,254	8,716,382	9,359,735	6,888,855
Sheep and goat <sup>5</sup> .....	3,686,466	2,607,328	3,325,525	3,255,788	2,648,163
<b>France:</b>					
Calf.....	29,348,958	28,013,852	25,492,892	25,574,903	135,653,673
Goat.....	6,118,647	6,062,430	8,298,114	4,060,432	16,235,932
Kid.....	426,590	807,325	922,405	1,515,442	2,406,541
Lamb.....	1,040,351	1,403,448	2,602,971	1,397,496	1,370,159
Large.....	71,434,772	65,526,885	75,216,322	68,246,479	172,304,928
Sheep.....	14,950,495	12,376,183	14,894,498	14,683,077	14,261,998
Hides and skins, unclassified.....	2,388,905	2,510,158	1,547,850	1,777,128	1,203,271

<sup>1</sup> Preliminary

<sup>2</sup> Included in "Hides, not elsewhere specified."

<sup>3</sup> Number of pounds computed from stated number of hides or skins.

<sup>4</sup> Unofficial estimate.

<sup>5</sup> Year preceding.

TABLE 139.—*International trade in hides and skins, calendar years, 1907–1911—Contd.*

## EXPORTS—Continued.

Country and classification.	1907	1908	1909	1910	1911
<b>Germany:</b>	<i>Pounds.</i>	<i>Pounds.</i>	<i>Pounds.</i>	<i>Pounds.</i>	<i>Pounds.</i>
Calf.....	17,197,423	22,823,122	23,860,386	18,215,728	27,600,490
Cattle.....	77,365,807	92,966,659	104,211,662	108,257,103	97,735,650
Goat.....	1,949,087	2,633,836	3,272,067	2,489,214	2,376,779
Horse.....	11,701,355	12,673,364	15,580,349	19,012,911	17,674,940
Sheep.....	5,472,699	5,125,915	6,307,802	6,448,675	5,310,661
Hides and skins, unclassified.....	563,716	284,173	411,599	409,394	729,723
<b>Italy:</b>					
Cattle.....	22,843,845	31,725,737	35,711,434	34,733,032	29,063,242
Calf.....	1,976,203	3,600,994	6,208,595	5,062,643	4,574,986
Goat.....	841,937	907,854	863,983	412,260	849,212
Kid.....	483,028	616,847	610,454	583,117	877,431
Lamb.....	1,145,510	1,232,151	2,172,413	2,491,859	2,234,803
Sheep.....	1,071,215	2,059,096	1,076,727	578,046	912,484
Hides and skins, unclassified.....	1,609,578	1,474,657	1,755,964	1,526,465	1,067,026
<b>Mexico:</b>					
Alligator.....	189,302	329,015	370,243	258,377	1 258,377
Cattle.....	17,930,497	19,811,484	31,327,273	37,906,613	1 37,906,613
Deer.....	802,254	734,189	802,115	711,396	1 711,396
Goat.....	6,649,210	7,817,260	7,884,509	7,191,806	1 7,191,806
Sheep.....	46,696	14,158	131,906	24,705	1 24,705
<b>Netherlands:</b>					
Hides, dried.....	19,843,900	18,702,817	21,283,885	21,693,264	22,470,793
Hides, fresh.....	165,449	149,754	213,363	182,995	176,584
Hides, salted.....	32,886,454	36,715,217	45,216,518	44,367,515	43,271,889
Sheep.....	1,820,618	2,651,252	2,264,680	1,657,711	1,367,983
<b>New Zealand:</b>					
Hides, unclassified <sup>2</sup> .....	6,393,835	6,260,275	6,619,025	6,137,145	4,544,443
Sheep.....	16,158,949	14,462,904	17,746,124	18,670,998	17,453,437
Skins, unclassified.....	976,500	623,736	868,134	709,938	921,360
<b>Peru:</b>					
Cattle.....	5,231,101	4,356,698	3,805,183	4,460,691	1 4,460,691
Goat.....	721,054	725,461	1,421,672	855,356	1 855,356
Sheep.....	238,683	124,966	178,570	81,162	1 81,162
Hides and skins, unclassified.....	20,611	6,221	97		
<b>Russia:</b>					
Hides, large.....	15,103,890	6,377,701	20,422,836	18,405,972	1 61,211,196
Hides, small.....	24,572,738	24,924,224	41,005,832	26,475,558	
Sheep and goat.....	26,956,761	14,742,726	17,951,890	19,941,235	1 21,414,890
<b>Singapore:</b>					
Hides, unclassified.....	6,524,667	5,107,467	5,879,867	6,856,267	1 6,856,267
<b>Spain:</b>					
Goat.....	1,733,755	1,976,406	2,312,167	1,943,465	1,865,228
Sheep.....	5,435,999	5,243,033	7,165,781	7,083,093	7,746,296
Hides and skins, unclassified.....	7,595,224	6,925,813	8,435,009	7,620,499	6,939,721
<b>Sweden:</b>					
Cattle, wet.....	11,381,292	13,375,026	18,130,353	20,731,567	28,064,765
Cattle, dry.....	770,812	557,689	602,971	343,400	522,867
Horse, wet.....	588,284	485,834	613,165	756,275	711,096
Horse, dry.....	2,114	1,473	3,413	979	364
Goat, kid, lamb, and sheep, wet.....	286,161	354,548	386,949	297,213	321,261
Goat, lamb, and sheep, dry.....	129,789	142,060	166,853	81,769	89,322
Hides and skins, unclassified, dry.....	67,163	31,030	8,609	5,071	4,625
Hides and skins, unclassified, wet.....	4,513	5,930	7,582	2,683	18,796
<b>Switzerland:</b>					
Hides, unclassified.....	14,900,450	16,234,895	15,471,001	14,918,087	14,884,357
Skins, unclassified.....	6,713,668	7,115,787	7,341,979	7,571,478	7,219,624
<b>United Kingdom:</b>					
Hides, unclassified.....	21,690,144	27,167,728	31,929,408	22,059,744	19,735,520
Sheepskin <sup>2</sup> .....	16,162,259	10,427,626	17,490,346	14,796,510	16,215,089
<b>United States:</b>					
Hides and skins, unclassified.....	11,126,157	14,915,857	9,922,887	30,586,908	36,115,677
<b>Uruguay:</b> <sup>4</sup>					
Calf.....	293,167	385,822	484,486	429,429	1 429,429
Cattle, dried.....	12,318,137	20,747,715	23,680,550	18,559,618	1 18,559,618
Cattle, salted <sup>2</sup> .....	23,310,784	22,812,832	23,811,312	29,484,700	1 29,484,700
Goat.....	74	2,852	31	105	1 105
Horse, dried <sup>2</sup> .....	247,968	313,536	717,104	526,080	1 526,080
Horse, salted <sup>2</sup> .....	225,016	117,172	209,880	53,856	1 53,856
Lamb.....	217,830	429,926	591,538	503,015	1 503,015
Sheep.....	14,644,497	18,902,236	21,133,415	20,879,207	1 20,879,207
Yearling, dried.....	2,142,014	2,493,949	4,561,822	3,112,289	1 3,112,289
Yearling, salted.....	64,927	52,407	113,635	100,221	1 100,221

<sup>1</sup> Year preceding.<sup>2</sup> Number of pounds computed from stated number of hides or skins.<sup>3</sup> Preliminary.<sup>4</sup> Year beginning July 1.

TABLE 139.—International trade in hides and skins, calendar years, 1907–1911—Contd.

EXPORTS—Continued.

Country and classification.	1907	1908	1909	1910	1911
<b>Venezuela:</b>	<i>Pounds.</i>	<i>Pounds.</i>	<i>Pounds.</i>	<i>Pounds.</i>	<i>Pounds.</i>
Cattle.....	5,600,160	5,978,500	6,945,936	6,250,799	7,765,117
Deer.....			398,226	316,863	363,832
Goat.....	1,445,792	1,652,800	2,048,142	2,129,205	2,280,357
Sheep.....					2,932
<b>Other countries:</b>					
<b>Hides—</b>					
Cattle and buffalo.....	30,604,656	32,414,366	52,243,431	83,601,623	<sup>1</sup> 86,371,976
Horse.....	477,873	458,255	660,459	669,565	<sup>1</sup> 913,488
<b>Skins—</b>					
Alligator.....				114,424	<sup>2</sup> 114,424
Calf.....	3,731,792	3,264,842	5,017,414	4,520,709	<sup>1</sup> 4,486,659
Deer.....	1,172,320	890,971	1,002,138	1,127,498	<sup>1</sup> 667,388
Goat.....	10,408,252	12,903,566	21,075,452	77,175,158	<sup>1</sup> 76,001,614
Kid.....	463,340	787,323	584,043	637,943	<sup>1</sup> 7,644
Sheep and lamb.....	17,887,219	16,722,711	22,636,680	26,188,706	<sup>1</sup> 25,699,873
Sheep and goat mixed.....	7,428,674	12,160,599	14,586,888	14,851,180	<sup>1</sup> 15,539,764
<b>Hides and skins—</b>					
Large.....	14,733,890	13,195,745	12,159,859	1,746,925	<sup>1</sup> 1,388,922
Small.....	1,871,942	6,497,788	31,987		
Unclassified.....	38,849,397	28,231,928	46,256,514	134,978,379	<sup>1</sup> 145,609,642
<b>Total.....</b>	<b>1,446,728,166</b>	<b>1,537,921,900</b>	<b>1,890,440,087</b>	<b>2,039,237,666</b>	<b>2,101,426,066</b>
<b>All countries:</b>					
<b>Hides—</b>					
Cattle and buffalo.....	401,530,175	470,692,150	619,358,491	705,292,692	<sup>1</sup> 715,433,767
Horse.....	19,193,335	21,694,291	29,797,209	33,128,815	<sup>1</sup> 31,821,679
<b>Skins—</b>					
Alligator.....	189,302	329,015	370,243	372,801	<sup>1</sup> 372,801
Calf.....	70,701,325	83,978,941	93,168,414	83,834,309	<sup>1</sup> 102,044,429
Deer.....	2,190,208	1,876,520	2,438,252	2,638,840	<sup>1</sup> 2,222,377
Goat.....	102,995,392	114,665,247	160,027,611	199,887,405	<sup>1</sup> 197,757,131
Kid.....	3,074,012	4,199,222	4,632,922	4,856,937	<sup>1</sup> 5,416,828
Lamb.....	4,785,091	6,386,235	8,828,144	18,632,270	<sup>1</sup> 16,045,284
Sheep.....	172,930,483	174,558,330	222,542,764	210,211,369	<sup>1</sup> 203,826,263
Sheep and goat mixed.....	38,487,851	30,007,261	36,418,105	38,453,295	<sup>1</sup> 40,025,930
<b>Hides and skins—</b>					
Large (not otherwise classified).....	101,272,552	85,100,331	107,799,017	88,399,376	<sup>1</sup> 73,693,850
Small (not otherwise classified).....	26,444,680	31,422,012	41,037,819	26,475,558	
Unclassified.....	502,933,760	513,012,315	564,021,096	627,053,999	<sup>1</sup> 712,765,737
<b>Total.....</b>	<b>1,446,728,166</b>	<b>1,537,921,900</b>	<b>1,890,440,087</b>	<b>2,039,237,666</b>	<b>2,101,426,066</b>

IMPORTS.

<b>Austria-Hungary:</b>	<i>Pounds.</i>	<i>Pounds.</i>	<i>Pounds.</i>	<i>Pounds.</i>	<i>Pounds.</i>
Calf, dried.....	1,608,476	912,704	768,744	763,453	1,590,398
Calf, green.....	1,864,430	1,959,448	1,538,811	1,827,613	1,677,921
Cattle, dried.....	36,293,889	26,372,748	27,296,696	31,480,145	43,969,865
Cattle, green.....	27,209,835	30,166,865	15,321,750	27,987,397	42,488,154
Goat.....	1,243,394	1,055,122	1,335,106	1,333,122	1,366,191
Horse, dried.....	59,304	72,531	77,602	116,623	85,979
Horse, green.....	630,295	409,174	106,482	450,911	142,638
Kid.....	570,991	554,898	436,952	372,136	426,149
Lamb.....	7,591,540	10,358,534	9,719,640	11,607,660	10,193,409
Sheep.....	4,843,286	4,138,696	3,422,201	3,481,504	3,812,635
Hides and skins, unclassified.....	859,794	698,638	678,355	827,607	608,911
<b>Belgium:</b>					
Hides, green.....	137,851,257	151,930,748	164,383,378	170,606,697	186,469,548
<b>British India:</b>					
Cattle.....	10,171,671	9,120,911	9,846,607	11,080,747	20,861,161
Hides, unclassified.....	627,648	647,248	326,256	1,076,992	846,384
Skins, unclassified.....	4,934,990	4,142,786	1,781,538	4,205,194	4,434,972
<b>Canada:</b>					
Hides and skins, unclassified.....	<sup>3</sup> 30,000,000	<sup>3</sup> 29,000,000	38,915,816	44,389,653	41,825,735
<b>Denmark:</b>					
Hides and skins, unclassified.....	9,504,031	8,744,546	9,067,520	7,192,949	10,388,297
<b>Finland:</b>					
Hides, dried.....	2,698,166	2,504,380	2,561,542	3,571,011	3,185,821
Hides, green.....	6,237,210	3,593,483	6,885,490	9,143,964	3,937,238
Sheep.....	163,284	295,233	122,523	188,121	333,933

<sup>1</sup> Preliminary.

<sup>2</sup> Year preceding.

<sup>3</sup> Unofficial estimate.



TABLE 139.—*International trade in hides and skins, calendar years, 1907–1911—Contd.*

## IMPORTS—Continued.

Country and classification.	1907	1908	1909	1910	1911
<b>France:</b>	<i>Pounds.</i>	<i>Pounds.</i>	<i>Pounds.</i>	<i>Pounds.</i>	<i>Pounds.</i>
Calf.....	6,593,518	7,162,966	8,520,999	9,336,040	<sup>1</sup> 5,565,954
Goat.....	19,772,396	19,444,572	22,549,751	20,722,799	<sup>1</sup> 21,799,526
Kid.....	3,798,526	4,724,899	5,199,549	4,165,151	<sup>1</sup> 4,408,980
Lamb.....	251,324	254,852	313,053	261,245	<sup>1</sup> 230,160
Large.....	97,556,857	87,812,084	107,218,957	115,722,320	<sup>1</sup> 115,209,971
Sheep.....	3,100,074	5,825,435	4,556,247	5,322,345	<sup>1</sup> 5,968,073
Hides and skins, unclassified.....	1,445,777	1,696,881	2,088,197	1,424,833	<sup>1</sup> 600,533
<b>Germany:</b>					
Buffalo.....	2,927,047	2,640,229	3,291,909	4,011,270	4,629,880
Calf, dried.....	14,672,274	14,243,480	16,540,673	13,812,701	12,498,980
Calf, green.....	39,554,933	50,069,112	58,132,656	56,960,912	64,581,993
Cattle, dried.....	74,160,760	68,588,854	80,868,696	88,030,780	81,323,505
Cattle, green.....	161,335,274	172,920,006	167,881,392	207,397,525	217,517,741
Goat, with hair on.....	11,600,605	15,100,408	19,557,227	19,193,248	18,827,064
Goat, without hair.....	90,609	6,173	.....	441	.....
Horse, dried.....	5,081,383	3,193,584	5,402,152	6,036,856	6,203,965
Horse, green.....	21,788,062	18,303,030	20,312,964	24,323,352	23,480,974
Lamb.....	308,424	130,071	95,900	87,743	122,576
Sheep.....	808,427	1,730,170	976,638	1,613,547	2,022,721
Hides and skins, unclassified.....	1,863,989	1,706,801	1,659,402	1,675,055	2,014,123
<b>Greece:</b>					
Hides, unclassified.....	5,587,396	5,535,962	5,490,037	6,516,929	6,358,985
<b>Italy:</b>					
Calf.....	2,207,686	2,596,798	2,075,190	1,812,402	1,641,104
Cattle.....	35,113,125	40,242,989	41,005,340	46,998,104	54,066,933
Sheep.....	8,082,725	6,738,801	5,768,115	2,888,026	2,632,513
Goat.....	301,369	783,294	316,581	95,459	66,579
Kid.....	71,650	115,301	80,468	81,350	52,469
Lamb.....	661,160	216,933	343,036	405,426	722,006
Hides and skins, unclassified.....	168,431	643,523	530,868	121,914	121,253
<b>Japan:</b>					
Cattle.....	8,365,492	5,588,419	7,659,635	5,661,183	2,633,605
Deer.....	751,899	675,822	635,531	533,211	687,278
<b>Netherlands:</b>					
Hides, dried.....	29,418,143	27,211,160	30,073,802	32,938,565	34,208,492
Hides, fresh.....	9,090	15,653	32,566	23,393	6,490
Hides, salted.....	20,705,306	26,239,425	34,000,172	31,888,214	35,601,371
Sheep.....	3,226,348	4,030,236	4,214,752	4,511,754	3,732,813
<b>Norway:</b>					
Hides, dry.....	2,595,586	2,749,533	3,262,764	3,146,119	3,598,150
Hides, green.....	7,565,879	8,405,765	11,585,482	8,802,549	10,340,037
Hides, salted.....	29,762	54,233	52,977	80,336	61,508
Skins, unclassified.....	47,273	14,550	23,631	108,685	29,833
<b>Portugal:</b>					
Hides, dried.....	5,404,542	5,681,891	5,147,796	6,898,279	<sup>2</sup> 6,898,279
Hides, green.....	142,036	105,669	106,894	57,115	<sup>2</sup> 57,115
<b>Roumania:</b>					
Buffalo and cattle.....	6,301,607	7,834,489	4,934,367	5,686,986	<sup>2</sup> 5,686,986
Calf.....	50,523	59,169	46,230	15,060	<sup>2</sup> 15,060
Sheep, lamb, and goat.....	653,205	533,707	442,971	725,309	<sup>2</sup> 725,309
Hides and skins, unclassified.....	10,102	39,017	1,254	2	<sup>2</sup> 2
<b>Russia:</b>					
Hides, dry.....	10,633,089	13,646,485	13,584,371	14,100,640	<sup>1</sup> 10,581,050
Hides, green.....	59,806,336	83,458,956	74,282,441	88,605,824	<sup>1</sup> 82,012,169
Goat and kid.....	1,795,384	2,310,930	3,454,984	3,914,989	<sup>1</sup> 1,997,037
Sheep.....	7,841,352	8,605,030	10,074,641	9,694,120	<sup>1</sup> 1,372,286
<b>Singapore:</b>					
Hides, unclassified.....	8,492,933	8,487,733	9,103,067	7,791,467	<sup>2</sup> 7,791,467
<b>Spain:</b>					
Hides and skins, unclassified.....	17,287,838	18,394,559	16,932,448	18,797,616	20,074,700
<b>Sweden:</b>					
Cattle, wet.....	14,887,512	13,027,248	17,503,243	20,404,532	18,510,743
Cattle, dry.....	4,642,764	3,412,783	4,955,224	6,244,569	5,333,646
Horse, wet.....	116,050	14,868	9,577	8,887	62,037
Horse, dry.....	10,926	28,519	30,218	13	.....
Goat, kid, lamb, and sheep, wet.....	197,052	267,793	206,860	417,882	235,546
Goat, lamb, and sheep, dry.....	259,283	259,468	248,223	404,332	309,658
Hides and skins, unclassified, wet.....	195,641	1,052	229	1,378	<b>88</b>
Hides and skins, unclassified, dry.....	50,831	22,789	16,431	26,770	<b>23,142</b>

<sup>1</sup> Preliminary.<sup>2</sup> Year preceding.

TABLE 139.—International trade in hides and skins, calendar years, 1907–1911—Contd.

IMPORTS—Continued.

Country and classification.	1907	1908	1909	1910	1911
<b>United Kingdom:</b>	<i>Pounds.</i>	<i>Pounds.</i>	<i>Pounds.</i>	<i>Pounds.</i>	<i>Pounds.</i>
Goat <sup>1</sup> .....	5, 116, 856	4, 988, 832	5, 892, 858	7, 398, 220	8, 274, 800
Hides, dry.....	22, 232, 784	18, 764, 592	27, 304, 816	97, 458, 704	83, 756, 624
Hides, wet.....	48, 174, 448	63, 293, 440	60, 190, 928		
Sheep <sup>1</sup> .....	3, 047, 209	183, 889	( <sup>2</sup> )	1, 596, 512	655, 996
Skins, unclassified.....	568, 416	( <sup>3</sup> )	442, 648	3, 326, 612	3, 006, 096
<b>United States:</b>					
Calf.....			4 47, 062, 988	53, 157, 553	82, 628, 078
Cattle and buffalo.....	122, 932, 034	137, 922, 575	279, 044, 262	223, 497, 903	174, 378, 518
Goat.....	86, 252, 338	75, 857, 983	115, 167, 176	100, 719, 480	91, 065, 576
Horse.....			4 11, 237, 915	13, 016, 541	12, 054, 635
Sheep.....		20, 138, 987	63, 771, 930	59, 669, 263	57, 434, 466
Hides and skins, unclassified.....	146, 363, 578	94, 527, 337	56, 492, 232	10, 546, 338	7, 316, 703
<b>Other countries:</b>					
<b>Hides—</b>					
Cattle and buffalo.....	8, 595, 547	8, 890, 151	10, 438, 178	21, 427, 306	5 35, 611, 968
Horse.....	15, 066	3, 210	17, 400	69, 082	5 51, 568
<b>Skins—</b>					
Calf.....	100, 950	138, 252	47, 355	82, 005	.....
Deer.....		4, 502	6, 605	4, 019	5 4, 019
Goat.....	441, 129	65, 036	442, 378	274, 531	5 255, 122
Kid.....	12, 301	13, 940	12, 288	11, 535	5 9, 235
Sheep and lamb.....	802, 674	582, 216	1, 207, 075	1, 651, 192	5 1, 500, 156
Sheep and goat, mixed..	431	149, 209	100, 675	1, 891, 338	5 2, 201, 437
<b>Hides and skins—</b>					
Large (not otherwise classified).....	229, 212	882, 098	.....	34, 484	5 64, 652
Small (not otherwise classified).....	1, 700	331, 882	11, 047	.....	.....
Unclassified.....	31, 783, 890	21, 876, 093	27, 251, 167	40, 579, 679	5 44, 238, 865
<b>Total.....</b>	<b>1, 495, 091, 639</b>	<b>1, 508, 897, 076</b>	<b>1, 834, 142, 708</b>	<b>1, 878, 628, 348</b>	<b>1, 888, 458, 361</b>
<b>All countries:</b>					
<b>Hides—</b>					
Cattle and buffalo.....	515, 936, 557	526, 728, 267	670, 047, 299	705, 685, 381	5 715, 277, 310
Horse.....	27, 701, 086	22, 024, 916	37, 194, 310	44, 298, 210	5 42, 360, 678
<b>Skins—</b>					
Calf.....	66, 652, 700	77, 141, 929	134, 733, 646	138, 042, 432	5 170, 477, 268
Deer.....	751, 899	680, 324	642, 136	537, 230	5 691, 297
Goat.....	126, 614, 080	119, 612, 350	168, 716, 061	151, 690, 166	5 141, 740, 210
Kid.....	4, 453, 468	5, 409, 038	5, 729, 257	6, 594, 636	5 6, 810, 811
Lamb.....	8, 812, 448	10, 960, 390	10, 471, 629	13, 075, 297	5 11, 943, 997
Sheep.....	31, 975, 379	52, 268, 693	94, 114, 122	90, 762, 735	5 80, 356, 776
Sheep and goat, mixed..	1, 109, 971	1, 210, 177	998, 729	5, 219, 815	5 5, 638, 922
<b>Hides and skins—</b>					
Large (not otherwise classified).....	97, 786, 069	88, 694, 182	107, 218, 957	115, 756, 804	5 115, 274, 623
Small (not otherwise classified).....	1, 700	331, 882	11, 047	.....	.....
Unclassified.....	613, 296, 192	603, 834, 928	604, 265, 515	606, 965, 642	5 597, 886, 469
<b>Total.....</b>	<b>1, 495, 091, 639</b>	<b>1, 508, 897, 076</b>	<b>1, 834, 142, 708</b>	<b>1, 878, 628, 348</b>	<b>1, 888, 458, 361</b>

1 Number of pounds computed from stated number of hides or skins.  
 2 Excess of foreign exports over imports, 813,450 pounds.  
 3 Excess of foreign exports over imports, 664,460 pounds.  
 4 Data for July to December, inclusive, only.  
 5 Preliminary.

TABLE 140.—Number of animals on farms and ranges of the United States, as reported by the decennial censuses, on dates indicated.

Date.	Horses.	Mules.	Milch cows.	Other cattle.	Sheep.	Swine.
June 1, 1870.....	7, 145, 370	1, 125, 415	8, 935, 332	13, 566, 005	28, 477, 951	25, 134, 569*
June 1, 1880.....	10, 357, 488	1, 812, 808	12, 443, 120	22, 488, 550	35, 192, 074	47, 681, 700
June 1, 1890.....	14, 969, 467	2, 295, 532	16, 511, 950	33, 734, 128	35, 935, 364	57, 409, 583
June 1, 1900.....	18, 267, 020	3, 264, 615	17, 135, 633	50, 083, 777	61, 503, 713	62, 868, 041
Apr. 15, 1910.....	19, 833, 113	4, 209, 769	20, 625, 432	41, 178, 434	52, 447, 861	58, 185, 676

## HORSES AND MULES.

TABLE 141.—Number and value of horses and mules on farms in the United States, 1867-1913.

Jan. 1—	Horses.			Mules.		
	Number.	Price per head Jan. 1.	Farm value Jan. 1.	Number.	Price per head Jan. 1.	Farm value Jan. 1.
1867.....	5,401,000	\$59.05	\$318,924,000	822,000	\$66.94	\$55,048,000
1868.....	5,757,000	54.27	312,416,000	856,000	56.04	47,954,000
1869.....	6,333,000	62.57	396,222,000	922,000	79.23	73,027,000
1870.....	8,249,000	67.43	556,251,000	1,180,000	90.42	106,654,000
1871.....	8,702,000	71.14	619,039,000	1,242,000	91.98	114,272,000
1872.....	8,991,000	67.41	606,111,000	1,276,000	87.14	111,222,000
1873.....	9,222,000	66.39	612,273,000	1,310,000	85.15	111,546,000
1874.....	9,334,000	65.15	608,073,000	1,339,000	81.35	108,953,000
1875.....	9,504,000	61.10	580,708,000	1,394,000	71.89	100,197,000
1876.....	9,735,000	57.29	557,747,000	1,414,000	66.46	94,001,000
1877.....	10,155,000	55.83	567,017,000	1,444,000	64.07	92,482,000
1878.....	10,330,000	56.63	584,999,000	1,638,000	62.03	101,579,000
1879.....	10,939,000	52.36	572,712,000	1,713,000	56.00	95,942,000
1880.....	11,202,000	54.75	613,297,000	1,730,000	61.26	105,948,000
1881.....	11,430,000	58.44	667,954,000	1,721,000	69.79	120,096,000
1882.....	10,522,000	58.53	615,825,000	1,835,000	71.35	130,945,000
1883.....	10,838,000	70.59	765,041,000	1,871,000	79.49	148,732,000
1884.....	11,170,000	74.64	833,734,000	1,914,000	84.22	161,215,000
1885.....	11,565,000	73.70	852,283,000	1,973,000	82.38	162,497,000
1886.....	12,078,000	71.27	860,823,000	2,053,000	79.60	163,381,000
1887.....	12,497,000	72.15	901,686,000	2,117,000	78.91	167,058,000
1888.....	13,173,000	71.82	946,096,000	2,192,000	79.78	174,854,000
1889.....	13,663,000	71.89	982,195,000	2,258,000	79.49	179,444,000
1890.....	14,214,000	68.84	978,517,000	2,331,000	78.25	182,394,000
1891.....	14,057,000	67.00	941,823,000	2,297,000	77.88	178,847,000
1892.....	15,498,000	65.01	1,007,594,000	2,315,000	75.55	174,882,000
1893.....	16,207,000	61.22	992,225,000	2,331,000	70.68	164,764,000
1894.....	16,081,000	47.83	769,225,000	2,352,000	62.17	146,233,000
1895.....	15,895,000	36.29	576,731,000	2,383,000	47.55	110,928,000
1896.....	15,124,000	33.07	500,140,000	2,279,000	45.29	103,204,000
1897.....	14,365,000	31.51	452,649,000	2,216,000	41.66	92,302,000
1898.....	13,961,000	34.26	478,362,000	2,190,000	43.88	96,110,000
1899.....	13,665,000	37.40	511,075,000	2,134,000	44.96	95,963,000
1900.....	13,538,000	44.61	603,969,000	2,086,000	58.55	111,717,000
1901 <sup>1</sup> .....	16,745,000	52.86	885,200,000	2,864,000	68.97	183,232,000
1902.....	16,531,000	58.61	968,935,000	2,757,000	67.61	186,412,000
1903.....	16,557,000	62.25	1,030,706,000	2,728,000	72.49	197,753,000
1904.....	16,736,000	67.93	1,136,940,000	2,758,000	78.88	217,533,000
1905.....	17,058,000	70.37	1,209,310,000	2,889,000	87.18	251,840,000
1906.....	18,719,000	80.72	1,510,890,000	3,404,000	98.31	334,681,000
1907.....	19,747,000	93.51	1,846,578,000	3,817,000	112.16	428,064,000
1908.....	19,992,000	93.41	1,867,530,000	3,869,000	107.76	416,939,000
1909.....	20,640,000	95.64	1,974,052,000	4,053,000	107.84	437,082,000
1910.....	21,040,000	108.19	2,276,365,000	4,123,000	119.84	494,085,000
1911 <sup>1</sup> .....	20,277,000	111.46	2,259,981,000	4,323,000	125.92	544,859,000
1912.....	20,509,000	105.94	2,172,694,000	4,362,000	120.51	525,657,000
1913.....	20,567,000	110.77	2,278,222,000	4,386,000	124.31	545,245,000

<sup>1</sup> Estimates of numbers revised, based on census data; see table 140, p. 677.

TABLE 142.—Number and value of horses and mules on farms, by States, January 1, 1912 and 1913.

State and division.	Horses.						Mules.					
	Number Jan. 1. <sup>1</sup>		Average price per head Jan. 1.		Farm value Jan. 1. <sup>1</sup>		Number Jan. 1. <sup>1</sup>		Average price per head Jan. 1.		Farm value Jan. 1. <sup>1</sup>	
	1913	1912	1913	1912	1913	1912	1913	1912	1913	1912	1913	1912
Maine.....	110	109	\$139.00	\$127.00	\$15,290	\$13,843	.....	.....	.....	.....	.....	.....
New Hampshire..	46	46	123.00	126.00	5,658	5,796	.....	.....	.....	.....	.....	.....
Vermont.....	84	84	127.00	121.00	10,668	10,164	.....	.....	.....	.....	.....	.....
Massachusetts...	64	64	146.00	144.00	9,344	9,216	.....	.....	.....	.....	.....	.....
Rhode Island.....	10	10	144.00	150.00	1,440	1,500	.....	.....	.....	.....	.....	.....
Connecticut.....	47	47	141.00	131.00	6,627	6,157	.....	.....	.....	.....	.....	.....
New York.....	609	609	137.00	133.00	83,433	80,997	4	4	\$157.00	\$150.00	\$628	\$600
New Jersey.....	90	91	147.00	143.00	13,230	13,013	4	4	189.00	160.00	676	640
Pennsylvania.....	578	572	133.00	130.00	76,874	74,360	44	44	149.00	147.00	6,556	6,468
North Atlantic..	1,638	1,632	135.88	131.77	222,564	215,046	52	52	151.15	148.23	7,860	7,708
Delaware.....	34	34	102.00	108.00	3,468	3,672	6	6	125.00	133.00	750	798
Maryland.....	163	163	116.00	112.00	18,908	18,256	23	23	142.00	140.00	3,266	3,220
Virginia.....	340	340	106.00	109.00	36,040	37,060	60	61	128.00	126.00	7,680	7,686
West Virginia....	184	182	116.00	113.00	21,344	20,566	12	12	126.00	122.00	1,512	1,464
North Carolina...	176	173	128.00	126.00	22,528	21,798	186	182	148.00	144.00	27,528	26,208
South Carolina...	83	82	140.00	135.00	11,620	11,070	168	166	171.00	165.00	28,728	27,390
Georgia.....	125	124	123.00	132.00	15,375	16,368	310	310	151.00	158.00	46,810	48,980
Florida.....	53	52	118.00	106.00	6,254	5,512	26	25	152.00	154.00	3,952	3,850
South Atlantic..	1,158	1,150	117.04	116.78	135,537	134,302	791	785	151.99	152.35	120,226	119,596
Ohio.....	892	901	130.00	126.00	115,960	113,526	24	24	131.00	127.00	3,144	3,048
Indiana.....	846	838	117.00	118.00	98,932	98,884	84	84	122.00	124.00	10,248	10,416
Illinois.....	1,482	1,497	120.00	115.00	177,840	172,155	149	151	131.00	123.00	19,519	18,573
Michigan.....	640	634	137.00	131.00	87,680	83,054	4	4	139.00	135.00	556	540
Wisconsin.....	665	652	131.00	124.00	87,115	80,848	3	3	131.00	125.00	393	375
N.C.E. Miss. R..	4,525	4,522	125.43	121.29	567,577	548,467	264	266	128.26	123.88	33,860	32,952
Minnesota.....	822	806	123.00	116.00	101,106	93,496	6	6	128.00	119.00	768	714
Iowa.....	1,568	1,568	120.00	113.00	188,160	177,184	56	57	124.00	119.00	6,944	6,783
Missouri.....	1,084	1,095	101.00	102.00	109,484	111,690	326	333	117.00	115.00	38,142	38,295
North Dakota....	712	691	124.00	114.00	88,288	78,774	8	8	141.00	127.00	1,128	1,016
South Dakota....	702	675	105.00	92.00	73,710	62,100	14	13	118.00	108.00	1,652	1,404
Nebraska.....	1,027	1,059	101.00	91.00	103,727	96,369	84	85	112.00	106.00	9,408	9,010
Kansas.....	1,099	1,169	103.00	96.00	113,197	112,224	222	218	114.00	108.00	25,308	23,544
N.C.W. Miss. R..	7,014	7,063	110.87	108.62	777,672	731,837	716	720	116.41	112.18	83,350	80,766
Kentucky.....	443	443	104.00	107.00	46,072	47,401	229	234	120.00	118.00	27,480	27,612
Tennessee.....	350	358	115.00	114.00	40,250	40,356	276	279	129.00	123.00	35,604	34,317
Alabama.....	146	143	106.00	99.00	15,476	14,157	270	265	131.00	127.00	35,370	33,651
Mississippi.....	236	234	92.00	89.00	21,712	20,826	280	277	114.00	113.00	31,920	31,505
Louisiana.....	187	187	87.00	79.00	16,269	14,773	133	134	127.00	116.00	16,891	15,544
Texas.....	1,181	1,158	82.00	74.00	96,842	85,692	724	703	110.00	104.00	79,640	73,112
Oklahoma.....	758	750	84.00	76.00	63,672	57,000	269	272	107.00	99.00	28,783	26,656
Arkansas.....	270	265	89.00	86.00	24,030	22,790	233	228	115.00	110.00	26,795	25,080
South Central..	3,571	3,534	90.82	85.74	324,323	302,995	2,414	2,392	117.02	111.74	282,483	267,277
Montana.....	354	347	93.00	87.00	32,922	30,189	4	4	109.00	91.00	436	364
Wyoming.....	157	159	76.00	69.00	11,932	10,971	2	2	109.00	99.00	218	198
Colorado.....	324	321	87.00	80.00	28,188	25,680	17	17	104.00	100.00	1,768	1,700
New Mexico.....	191	185	58.00	50.00	11,078	9,250	15	15	90.00	86.00	1,350	1,290
Arizona.....	108	104	78.00	69.00	8,424	7,176	5	4	119.00	116.00	595	472
Utah.....	135	131	93.00	93.00	12,555	12,183	2	2	92.00	85.00	184	170
Nevada.....	75	72	87.00	77.00	6,525	5,544	3	3	95.00	82.00	285	246
Idaho.....	223	214	100.00	96.00	22,300	20,544	4	4	108.00	112.00	432	448
Washington.....	299	293	110.00	107.00	32,890	31,351	14	14	117.00	112.00	1,638	1,568
Oregon.....	292	289	99.00	102.00	28,908	29,478	10	10	107.00	111.00	1,070	1,110
California.....	503	493	109.00	117.00	54,827	57,681	73	72	130.00	136.00	9,490	9,792
Far Western...	2,661	2,698	94.16	92.04	250,549	240,047	149	147	117.22	118.08	17,466	17,358
United States..	20,567	20,509	110.77	105.94	2,278,222	2,172,694	4,386	4,362	124.31	120.51	545,245	525,657

<sup>1</sup> Expressed in thousands; 000 omitted.

TABLE 143.—Imports, exports, and price of horses and mules, 1892–1912.

Year ending June 30—	Imports of horses.			Exports of horses.			Exports of mules.		
	Number.	Value.	Average import price.	Number.	Value.	Average export price.	Number.	Value.	Average export price.
1892.....	14,074	\$2,455,868	\$174.50	3,226	\$611,188	\$189.46	1,965	\$238,591	\$121.42
1893.....	15,451	2,388,267	154.57	2,967	718,607	242.20	1,634	210,278	128.69
1894.....	6,166	1,319,572	214.01	5,246	1,108,995	211.40	2,063	240,961	116.80
1895.....	13,098	1,055,191	80.56	13,984	2,209,298	157.99	2,515	186,452	74.14
1896.....	9,991	662,591	66.32	25,126	3,530,703	140.52	5,918	406,161	68.63
1897.....	6,998	464,808	66.42	39,532	4,769,265	120.64	7,473	545,331	72.97
1898.....	3,085	414,899	134.49	51,150	6,176,569	120.75	8,098	664,789	82.09
1899.....	3,042	551,050	181.15	45,778	5,444,342	118.93	6,755	516,908	76.52
1900.....	3,102	596,592	192.32	64,722	7,612,616	117.62	43,369	3,919,478	90.38
1901.....	3,785	985,738	260.43	82,250	8,873,845	107.89	34,405	3,210,267	93.31
1902.....	4,832	1,577,234	326.41	103,020	10,048,046	97.53	27,586	2,692,298	97.60
1903.....	4,999	1,536,296	307.32	34,007	3,152,159	92.69	4,294	521,925	121.47
1904.....	4,726	1,460,287	308.99	42,001	3,189,100	75.93	3,658	412,971	112.90
1905.....	5,180	1,591,083	307.16	34,822	3,175,259	91.19	5,826	645,464	110.79
1906.....	6,021	1,716,675	285.11	40,087	4,365,981	108.91	7,167	989,639	138.08
1907.....	6,080	1,978,105	325.35	33,882	4,359,957	131.99	6,781	850,901	125.48
1908.....	5,487	1,604,392	292.40	19,000	2,612,587	137.50	6,609	990,667	149.90
1909.....	7,084	2,007,276	283.35	21,616	3,386,617	156.67	3,432	472,017	137.53
1910.....	11,620	3,296,022	283.65	28,910	4,081,157	141.17	4,512	614,094	136.10
1911.....	9,593	2,692,074	280.63	25,145	3,845,253	152.92	6,585	1,070,051	162.50
1912.....	6,607	1,923,025	291.06	34,828	4,764,815	136.81	4,901	732,095	149.38

## CATTLE.

TABLE 144.—Imports, exports, and prices of live cattle, 1892–1912.

Year ending June 30—	Imports.			Exports.		
	Number.	Value.	Average import price.	Number.	Value.	Average export price.
1892.....	2,168	\$47,466	\$21.89	394,607	\$35,099,095	\$88.95
1893.....	3,293	45,682	13.87	287,094	26,032,428	90.68
1894.....	1,592	18,704	11.75	359,278	33,461,922	93.14
1895.....	149,781	765,853	5.11	331,722	30,603,796	92.26
1896.....	217,826	1,509,856	6.93	372,461	34,560,672	92.79
1897.....	328,977	2,589,857	7.87	392,190	36,357,451	92.70
1898.....	291,589	2,913,223	9.99	439,255	37,827,500	86.12
1899.....	199,752	2,320,362	11.62	389,490	30,516,833	78.35
1900.....	181,006	2,257,694	12.47	397,286	30,635,153	77.11
1901.....	146,022	1,931,433	13.23	459,218	37,566,980	81.81
1902.....	96,027	1,608,722	16.75	392,884	29,902,212	76.11
1903.....	66,175	1,161,548	17.55	402,178	29,848,936	74.22
1904.....	16,056	310,737	19.35	593,409	42,256,291	71.21
1905.....	27,855	458,572	16.46	567,806	40,598,048	71.50
1906.....	29,019	548,430	18.90	584,239	42,081,170	72.03
1907.....	32,402	565,122	17.44	423,051	34,577,392	81.73
1908.....	92,356	1,507,310	16.32	349,210	29,339,134	84.02
1909.....	139,184	1,999,422	14.37	207,542	18,046,976	86.96
1910.....	195,938	2,999,824	15.37	139,430	12,200,154	87.50
1911.....	182,923	2,953,077	16.14	150,100	13,163,920	87.70
1912.....	318,372	4,805,574	15.09	105,506	8,870,075	84.07

**TABLE 145.**—*Number and value of milch cows and other cattle on farms in the United States, 1867-1913.*

January 1—	Milch cows.			Other cattle.		
	Number.	Price per head Jan. 1.	Farm value Jan. 1.	Number.	Price per head Jan. 1.	Farm value Jan. 1.
1867.....	8,349,000	\$28.74	\$239,947,000	11,731,000	\$15.79	\$185,254,000
1868.....	8,692,000	26.56	230,817,000	11,942,000	15.06	179,888,000
1869.....	9,248,000	29.15	269,610,000	12,185,000	18.73	228,183,000
1870.....	10,096,000	32.70	330,175,000	15,388,000	18.87	290,401,000
1871.....	10,023,000	33.89	339,701,000	16,212,000	20.78	336,860,000
1872.....	10,304,000	29.45	303,438,000	16,390,000	18.12	296,932,000
1873.....	10,576,000	26.72	282,559,000	16,414,000	18.06	296,448,000
1874.....	10,705,000	25.63	274,326,000	16,218,000	17.55	284,706,000
1875.....	10,907,000	25.74	280,701,000	16,313,000	16.91	275,872,000
1876.....	11,085,000	25.61	283,879,000	16,785,000	17.00	285,387,000
1877.....	11,261,000	25.47	286,778,000	17,956,000	15.99	287,156,000
1878.....	11,300,000	25.74	290,898,000	19,223,000	16.72	321,346,000
1879.....	11,826,000	21.71	256,721,000	21,408,000	15.38	329,254,000
1880.....	12,027,000	23.27	279,899,000	21,231,000	16.10	341,761,000
1881.....	12,369,000	23.95	296,277,000	20,939,000	17.33	362,862,000
1882.....	12,612,000	25.89	326,489,000	23,280,000	19.89	463,070,000
1883.....	13,126,000	30.21	396,575,000	28,046,000	21.81	611,549,000
1884.....	13,501,000	31.37	423,487,000	29,046,000	23.52	683,229,000
1885.....	13,905,000	29.70	412,903,000	29,867,000	23.25	694,383,000
1886.....	14,235,000	27.40	389,986,000	31,275,000	21.17	661,956,000
1887.....	14,522,000	26.08	378,790,000	33,512,000	19.79	663,138,000
1888.....	14,856,000	24.65	366,252,000	34,378,000	17.79	611,751,000
1889.....	15,299,000	23.94	366,226,000	35,032,000	17.05	597,237,000
1890.....	15,953,000	22.14	353,152,000	36,849,000	15.21	560,625,000
1891.....	16,020,000	21.62	346,398,000	36,876,000	14.76	544,128,000
1892.....	16,416,000	21.40	351,378,000	37,651,000	15.16	570,749,000
1893.....	16,424,000	21.75	357,300,000	35,954,000	15.24	547,882,000
1894.....	16,487,000	21.77	358,999,000	36,608,000	14.66	536,790,000
1895.....	16,505,000	21.97	362,602,000	34,364,000	14.06	482,999,000
1896.....	16,138,000	22.55	363,956,000	32,085,000	15.86	508,928,000
1897.....	15,942,000	23.16	369,240,000	30,508,000	16.65	507,929,000
1898.....	15,841,000	27.45	434,814,000	29,264,000	20.92	612,297,000
1899.....	15,990,000	29.66	474,234,000	27,994,000	22.79	637,931,000
1900.....	16,292,000	31.60	514,812,000	27,610,000	24.97	689,486,000
1901 <sup>1</sup> .....	16,834,000	30.00	505,093,000	45,500,000	19.93	906,644,000
1902.....	16,697,000	29.23	488,130,000	44,728,000	18.76	839,126,000
1903.....	17,105,000	30.21	516,712,000	44,659,000	18.45	824,055,000
1904.....	17,420,000	29.21	508,841,000	43,629,000	16.32	712,178,000
1905.....	17,572,000	27.44	482,272,000	43,669,000	15.15	661,571,000
1906.....	19,794,000	29.44	582,789,000	47,068,000	15.85	746,172,000
1907.....	20,968,000	31.00	645,497,000	51,566,000	17.10	881,557,000
1908.....	21,194,000	30.67	650,057,000	50,073,000	16.89	845,938,000
1909.....	21,720,000	32.36	702,945,000	49,379,000	17.49	863,754,000
1910.....	21,801,000	35.79	780,308,000	47,279,000	19.41	917,453,000
1911 <sup>1</sup> .....	20,823,000	39.97	832,209,000	39,679,000	20.54	815,184,000
1912.....	20,699,000	39.39	815,414,000	37,260,000	21.20	790,064,000
1913.....	20,497,000	45.02	922,783,000	36,030,000	26.36	949,645,000

<sup>1</sup> Estimates of numbers revised, based on census data; see Table 140, p. 677.

TABLE 146.—Number and value of cattle on farms, by States, Jan. 1, 1912 and 1913.

State and division.	Milk cows.						Other cattle.					
	Number Jan. 1. <sup>1</sup>		Average price per head Jan. 1.		Farm value Jan. 1. <sup>1</sup>		Number Jan. 1. <sup>1</sup>		Average price per head Jan. 1.		Farm value Jan. 1. <sup>1</sup>	
	1913	1912	1913	1912	1913	1912	1913	1912	1913	1912	1913	1912
Maine.....	157	155	\$46.00	\$44.00	\$7,222	\$6,820	99	98	\$21.20	\$19.80	\$2,099	\$1,940
New Hampshire.....	96	97	48.00	44.00	4,608	4,268	66	65	24.00	21.60	1,584	1,404
Vermont.....	265	268	44.50	42.00	11,792	11,256	168	168	18.30	18.20	3,074	3,058
Massachusetts.....	165	167	51.00	50.00	8,415	8,356	81	80	19.90	18.80	1,612	1,504
Rhode Island.....	23	23	52.50	50.40	1,208	1,159	11	11	20.60	20.00	227	220
Connecticut.....	118	120	51.70	49.20	6,101	5,904	71	71	22.50	21.00	1,598	1,491
New York.....	1,465	1,495	50.00	43.30	73,250	64,734	876	894	22.00	19.80	19,272	17,701
New Jersey.....	146	150	55.20	53.20	8,059	7,980	66	68	25.10	24.10	1,657	1,639
Pennsylvania.....	943	943	46.60	43.70	43,944	41,209	614	627	23.60	21.70	14,490	13,606
N. Atlantic.....	3,378	3,418	48.73	44.38	164,599	151,680	2,052	2,082	22.23	20.44	45,613	42,563
Delaware.....	38	37	42.20	37.00	1,604	1,369	19	19	23.80	22.00	452	418
Maryland.....	168	168	42.60	37.00	7,157	6,216	120	119	24.60	21.40	2,952	2,547
Virginia.....	345	352	34.00	31.40	11,730	11,053	459	478	23.20	19.90	10,649	9,512
West Virginia.....	230	230	42.00	33.80	9,660	7,774	331	331	29.00	22.10	9,599	7,315
North Carolina.....	312	312	30.10	28.00	9,391	8,736	372	380	14.90	12.60	5,543	4,788
South Carolina.....	185	185	32.50	32.30	6,012	5,976	215	215	14.20	13.20	3,053	2,838
Georgia.....	402	406	28.50	28.00	11,457	11,368	667	667	11.00	11.00	7,337	7,337
Florida.....	123	123	36.00	33.50	4,428	4,120	766	758	12.20	13.10	9,345	9,930
S. Atlantic.....	1,803	1,813	34.08	31.23	61,439	56,612	2,949	2,967	16.59	15.06	48,930	44,685
Ohio.....	869	887	50.00	42.00	43,450	37,254	814	885	29.80	24.30	24,257	21,506
Indiana.....	634	634	45.70	41.00	28,974	25,994	686	707	30.10	24.50	20,649	17,322
Illinois.....	1,007	1,049	51.00	45.50	51,357	47,730	1,228	1,266	31.50	26.60	38,682	33,676
Michigan.....	798	806	45.00	40.50	35,910	32,643	673	701	22.10	18.80	14,873	13,179
Wisconsin.....	1,504	1,504	47.70	40.40	71,741	60,762	1,135	1,146	21.70	18.00	24,630	20,623
N. C. E. Miss. R.....	4,812	4,880	48.09	41.88	231,432	204,383	4,536	4,705	27.14	22.60	123,091	106,311
Minnesota.....	1,129	1,107	45.00	36.60	50,805	40,516	1,139	1,151	20.00	15.30	22,780	17,610
Iowa.....	1,337	1,393	50.30	40.80	67,251	56,334	2,607	2,773	33.00	25.00	86,031	69,325
Missouri.....	789	822	45.30	40.20	35,742	33,044	1,444	1,604	31.10	25.30	44,908	38,051
North Dakota.....	277	272	47.00	37.00	13,019	10,064	437	446	27.20	21.00	11,886	9,366
South Dakota.....	384	366	48.00	38.00	18,432	13,908	894	894	32.30	22.20	28,876	19,847
Nebraska.....	607	613	49.60	40.60	30,107	24,888	1,902	2,002	32.40	24.50	61,625	49,049
Kansas.....	698	698	49.20	41.00	34,342	28,618	1,778	1,872	33.40	26.40	59,385	49,421
N. C. W. Miss. R.....	5,221	5,271	47.83	39.42	249,698	207,872	10,201	10,642	30.93	23.74	315,491	252,669
Kentucky.....	390	398	38.80	35.30	15,132	14,049	555	561	25.90	21.10	14,374	11,837
Tennessee.....	366	385	33.10	32.00	12,115	12,320	530	576	16.90	14.70	8,957	8,467
Alabama.....	396	396	27.00	26.00	10,692	10,296	535	540	10.10	9.60	5,404	5,184
Mississippi.....	434	443	27.70	26.00	12,022	11,518	521	566	10.40	10.00	5,418	5,660
Louisiana.....	271	288	29.00	29.50	7,859	8,496	444	516	12.00	11.20	5,328	5,779
Texas.....	1,034	1,034	39.90	35.10	41,257	36,293	5,022	5,177	22.60	17.00	113,497	88,009
Oklahoma.....	484	504	43.00	35.40	20,812	17,842	1,155	1,242	27.60	21.50	31,878	26,703
Arkansas.....	392	404	28.60	27.00	11,211	10,908	500	538	12.20	11.40	6,100	6,133
S. Central.....	3,767	3,852	34.80	31.60	131,100	121,722	9,262	9,716	20.62	16.24	190,956	157,772
Montana.....	95	91	61.00	49.40	5,795	4,495	717	732	38.40	29.80	27,533	21,814
Wyoming.....	36	35	58.00	48.00	2,088	1,680	506	568	38.80	28.80	19,633	16,358
Colorado.....	172	167	53.80	47.00	9,254	7,849	921	921	34.10	27.60	31,406	25,420
New Mexico.....	56	53	47.80	43.00	2,677	2,279	891	900	29.00	23.40	25,839	21,060
Arizona.....	34	32	58.00	51.00	1,972	1,632	778	741	29.20	23.30	22,718	17,265
Utah.....	85	83	49.00	40.00	4,165	3,320	352	356	28.50	21.50	10,032	7,654
Nevada.....	20	20	52.00	50.00	1,040	1,000	433	429	33.30	26.10	14,419	11,167
Idaho.....	102	94	59.60	48.50	6,079	4,559	340	343	33.50	25.50	11,390	8,746
Washington.....	219	205	62.50	54.00	13,688	11,070	186	186	30.50	24.40	5,673	4,538
Oregon.....	187	180	56.00	47.20	10,472	8,496	452	457	32.00	25.30	14,464	11,562
California.....	510	505	53.50	53.00	27,285	26,765	1,454	1,515	29.20	26.70	42,457	40,450
Far Western.....	1,516	1,465	55.75	49.93	84,515	73,145	7,030	7,148	32.09	26.03	225,564	186,064
United States.....	20,497	20,699	45.02	39.39	922,783	815,414	36,030	37,260	26.36	21.20	949,645	790,064

<sup>1</sup> Expressed in thousands; 000 omitted.

TABLE 147.—Wholesale price of cattle per 100 pounds, 1899–1912.

Date.	Chicago.		Cincinnati.		St. Louis.		Kansas City.		
	Inferior to prime.		Fair to medium.		Good to choice native steers.		Common to prime.		
	Low.	High.	Low.	High.	Low.	High.	Low.	High.	
1899.....	\$2.00	\$7.00	\$3.00	\$4.50	\$4.00	\$6.00	\$3.75	\$6.80	
1900.....	1.75	6.60	3.00	4.70	4.00	6.50	3.90	6.50	
1901.....	2.10	7.00	2.90	5.05	4.75	8.25	4.00	7.00	
1902.....	1.90	14.50	3.00	5.40	5.15	8.75	4.10	8.75	
1903.....	1.50	8.35	2.25	4.40	5.00	6.00	3.75	6.00	
1904.....	1.70	7.65	2.25	4.25	4.90	6.60	4.25	7.00	
1905.....	1.85	7.00	2.35	4.75	5.15	7.10	4.00	7.05	
1906.....	1.75	7.90	2.35	4.50	5.45	7.00	4.10	7.50	
1907.....	2.00	8.00	4.10	6.00	5.35	7.35	3.90	8.25	
1908.....	2.00	8.40	2.65	5.50	5.50	8.25	3.50	8.25	
1909.									
January.....	2.90	7.50	3.60	5.00	5.70	7.00	4.00	6.90	
February.....	3.00	7.15	3.85	4.75	6.15	6.75	4.00	6.75	
March.....	3.05	7.40	3.85	5.00	6.75	7.00	4.50	7.10	
April.....	3.15	7.15	3.85	4.90	6.75	7.00	4.15	6.75	
May.....	3.30	7.30	4.00	5.25	6.60	7.00	4.00	7.00	
June.....	3.15	7.25	3.75	5.50	7.00	7.15	4.25	7.25	
July.....	3.10	7.45	3.50	5.25	7.00	7.40	4.10	7.65	
August.....	3.00	8.00	3.35	5.25	7.10	7.65	3.90	7.80	
September.....	3.00	8.50	3.25	5.00	7.50	8.50	3.70	8.25	
October.....	3.05	9.10	3.00	4.85	8.00	8.75	4.00	10.25	
November.....	3.05	9.25	3.25	4.85	7.25	8.25	4.35	9.00	
December.....	3.00	9.50	3.50	5.10	6.40	10.50	4.35	10.50	
Year.....	2.90	9.50	3.00	5.50	5.70	10.50	3.70	10.50	
1910.									
January.....	2.90	8.40	3.35	5.00	6.75	7.50	4.35	7.40	
February.....	3.00	8.10	3.35	5.25	6.75	7.35	4.75	7.50	
March.....	3.25	8.85	4.50	6.25	7.50	8.50	5.40	8.40	
April.....	3.50	8.75	4.35	6.50	8.00	8.35	5.75	8.40	
May.....	4.25	8.75	4.00	6.25	7.75	8.50	5.40	8.30	
June.....	3.00	8.85	3.75	6.00	8.20	8.60	4.50	8.50	
July.....	3.00	8.60	3.65	5.75	8.00	8.25	3.60	8.25	
August.....	3.15	8.50	3.00	5.35	7.85	8.25	3.75	8.25	
September.....	3.15	8.50	3.10	5.25	7.50	7.90	4.00	8.10	
October.....	3.00	8.20	3.00	4.90	7.25	8.00	3.90	8.60	
November.....	3.00	7.75	3.25	4.65	6.80	7.35	4.20	7.35	
December.....	3.00	7.55	3.65	4.85	6.35	7.75	4.30	7.35	
Year.....	2.90	8.85	3.00	6.50	6.35	8.50	3.60	8.60	
1911.									
January.....	3.25	7.10	3.75	5.00	6.75	6.80	5.00	6.75	
February.....	3.40	7.05	4.00	5.00	6.60	6.90	5.05	6.75	
March.....	3.40	7.05	4.00	5.00	6.50	6.75	5.15	6.75	
April.....	3.25	6.90	3.75	5.00	6.50	6.75	5.00	6.60	
May.....	3.35	6.50	3.60	5.10	6.25	6.60	5.00	6.35	
June.....	2.65	6.75	3.75	5.00	6.25	6.40	4.25	6.50	
July.....	2.50	7.35	3.50	5.10	6.50	7.00	4.25	7.20	
August.....	2.60	8.20	3.25	5.00	7.00	8.00	4.25	8.20	
September.....	3.00	8.25	3.65	5.25	7.95	8.25	4.50	8.15	
October.....	2.85	9.00	3.25	4.85	7.90	8.50	4.50	12.55	
November.....	2.75	9.25	3.25	4.75	7.60	9.00	4.75	9.25	
December.....	3.00	9.35	3.50	5.35	7.80	9.40	4.50	10.00	
Year.....	2.50	9.35	3.25	5.35	6.25	9.40	4.25	12.55	
1912.									
January.....	1.75	8.75	4.10	4.50	7.35	7.75	4.60	7.90	
February.....	1.75	9.00	4.10	4.50	7.65	8.00	4.85	8.15	
March.....	2.00	8.85	4.15	5.75	7.75	8.10	5.00	8.25	
April.....	2.25	9.00	4.40	5.85	7.90	8.60	5.35	8.75	
May.....	2.25	9.40	4.50	6.25	8.50	9.15	5.65	9.30	
June.....	2.25	9.60	4.50	6.25	9.00	9.50	5.75	9.50	
July.....	2.25	9.85	4.05	6.25	9.00	9.50	5.50	9.75	
August.....	2.60	10.65	4.25	6.25	9.75	10.50	6.00	10.60	
September.....	2.50	11.00	4.35	6.25	9.85	10.75	6.25	10.90	
October.....	2.50	11.05	4.10	6.15	10.60	11.00	6.00	12.40	
November.....	2.75	11.00	4.25	6.35	8.50	10.65	5.75	10.85	
December.....	2.75	11.25	4.75	6.75	8.30	8.50	5.85	11.10	
Year.....	1.75	11.25	4.05	6.75	7.35	11.00	4.60	12.40	



BUTTER.

TABLE 148.—Wholesale price of butter per pound, 1899-1912.

Date.	Elgin.		Chicago.				Cincinnati.		Milwaukee.		New York.	
	Creamery, extra.		Creamery, extra.		Dairies, firsts to extras.		Creamery, extra.		Creamery, fancy.		Creamery, extra.	
	Low.	High.	Low.	High.	Low.	High.	Low.	High.	Low.	High.	Low.	High.
1899.....	Cts. 16	Cts. 27	Cts. 14	Cts. 27	Cts. 11	Cts. 22	Cts. 16	Cts. 24	Cts. 9½	Cts. 27	Cts. 16½	Cts. 28
1900.....	18	29	15½	29	14½	25	16	27	19	29½	17½	30
1901.....	18½	24½	15	24½	14	20	17	24	18½	25	18	25½
1902.....	19	30	16	31	15½	29	17	27	19½	30½	19	33
1903.....	18½	29	16	28½	15	25	15½	27	18½	28	19	29½
1904.....	17	28	15	28	12½	24	17	28	17	27	17½	28
1905.....	19½	34	18	34	16	30	19	34	19½	34	17½	35½
1906.....	19	31½	16½	32	15	27	19	32½	19	31½	19½	33
1907.....	23	33	18	32½	18	30	23	34	23	33	23½	35
1908.....	21	33	19	33½	18	29	21	36	21	33½	21½	34
1909.....												
January.....	29	32	24	32	22	27	31	34	17	32	29	33
February.....	29	30	24	30	22	25	31	32	16	30	29	31½
March.....	29	30	25	29	22	25½	31	32	16	30	28½	30
April.....	26	30	24	29½	20½	25½	28	30	16	30	26	29
May.....	24	27	22	27	20	24½	26	29	15	26	26	29½
June.....	25	26½	23	27	21½	24½	27	28½	15	26½	25	26½
July.....	25½	26½	23	26	21½	23½	27½	28½	16	26½	25	27
August.....	26	29	23	28	21½	25	28	31	17	29	26	29
September.....	30	30	25	29½	23	26	32	33	18	30	29	31
October.....	30	31	26	30½	24	28	32	33	18	31	30	31½
November.....	30	32½	27½	31	26	28	32½	35	20	32½	30	32
December.....	33	36	28½	35	26	30	35½	38½	22	35	33	37
Year.....	24	36	22	35	20	30	26	38½	15	35	25	37
1910.....												
January.....	30	36	27	36	26	30	32½	38½	20	36	30	35
February.....	28	31	26	30	23	29	30½	33½	19	31	27½	30
March.....	31	32	27	32	25	27	33½	34½	19	32	32	34
April.....	29	32	26½	32½	24	28	32	35	18	32	29	34
May.....	27	29	25	28	23	26	29	31½	18	29	27½	28½
June.....	27	28	25½	27½	23½	26	29½	30	19	28	27	28½
July.....	27	28	24	28	23	25½	29	30½	19	28	27	29
August.....	28	30	24	29	23½	27	30½	32½	19	30	28	31
September.....	29	31	25	30	25	27	31½	33½	20	31	29	31
October.....	29	30½	25	29½	25	27	31½	32	20	29½	29	30½
November.....	30	31	26½	30½	25	27	32½	33½	21	31	30	31
December.....	29	30	25½	30	23	27	31½	32½	20½	31	29	30
Year.....	27	36	24	36	23	30	29½	38½	18	36	27½	35
1911.....												
January.....	25	29	20	29	19	25	27½	32½	25	30	25	29
February.....	25	26½	20	26½	19	22	27½	29	25	26½	24	27½
March.....	24	26	20	26½	17	22	26½	28½	24	26	19½	26
April.....	21	24	18	22	15	19	23½	26½	21	24	19½	22
May.....	21	23	18	22	15	20	23½	25½	21	23	21	25
June.....	21½	23	18	23	17	21	24	25½	21½	23	21½	24
July.....	23	26	20	24	19	22	23½	27½	23	25	24	26
August.....	26	26	21	26	20	23	28½	28½	26	26	26	27
September.....	26	26½	21	26	20	25	28½	29	26	26½	26	28
October.....	27½	31	23	31	22½	28	29	33½	26	31	28	32
November.....	31	33	27½	33	25	29	33½	37½	31	35	32	36½
December.....	35	36	26	37	27	33	37½	38½	35	36	34	39
Year.....	21	36	18	37	15	33	29½	38½	21	36	19½	39
1912.....												
January.....	36	40	36	40	28	34	38½	42½	36	40	34	41
February.....	27	36	26	34	23	31	29½	38½	27	36	28	35
March.....	28	30	28	30	24	28	30½	32½	28	30	28½	31½
April.....	30	32	30	32	25	28	32½	34½	30	32	30½	35½
May.....	25	31	25	31	22	28	27½	33½	25	31	26	35½
June.....	25	25½	25	25	22	24	27½	28½	25	25½	26	27½
July.....	25	25½	25	25	22	24	27½	28	25	25½	27	27½
August.....	25	25	24	25½	22	24	27½	27½	25	25	26	27½
September.....	25	30	26	30	22	28	28½	31	25	28½	27½	32
October.....	29	30	29	30	25	28	32½	32½	29	30	30½	32
November.....	29	34	30½	36	26	31	32½	37½	29	34	32	37
December.....	34	35½	34	37	27	33	37½	39	34	35½	37	38
Year.....	25	40	24	40	22	34	27½	42½	25	40	26	41

TABLE 149.—*International trade in butter, calendar years, 1907–1911.*

[Butter includes all butter made from milk, melted and renovated butter, but does not include margarine, cocoa butter, or ghee. See "General note," p. 554.]

## EXPORTS.

Country.	1907	1908	1909	1910	1911
	<i>Pounds.</i>	<i>Pounds.</i>	<i>Pounds.</i>	<i>Pounds.</i>	<i>Pounds.</i>
Argentina.....	6,691,913	7,825,602	8,802,359	6,341,589	3,076,813
Australia.....	66,076,915	51,193,311	55,644,925	87,894,943	101,722,136
Austria-Hungary.....	5,456,826	8,217,867	5,548,537	4,378,997	4,512,816
Belgium.....	3,755,190	3,821,526	3,998,906	3,509,265	3,345,134
Canada.....	4,835,497	5,994,144	4,375,004	3,673,702	9,712,206
Denmark.....	188,827,695	196,059,159	196,692,759	195,052,426	197,481,675
Finland.....	28,024,553	26,525,615	25,644,456	24,471,285	27,229,718
France.....	34,648,184	43,950,906	51,263,343	48,427,787	<sup>1</sup> 31,517,623
Germany.....	535,056	480,162	450,179	398,592	554,898
Italy.....	7,834,928	8,602,570	8,028,051	8,295,469	8,147,320
Netherlands.....	64,808,558	72,911,223	68,686,019	72,456,276	66,512,901
New Zealand.....	36,785,392	25,756,752	35,964,096	39,931,920	33,867,344
Norway.....	2,864,238	3,432,474	3,446,165	2,738,708	3,679,125
Russia.....	132,113,551	112,789,519	125,627,114	124,365,658	168,704,448
Sweden.....	38,226,922	40,030,309	42,362,456	47,949,953	48,888,522
United States.....	3,857,288	8,918,091	2,925,730	3,104,175	6,374,988
Other countries.....	3,089,000	3,223,000	5,299,000	3,860,000	<sup>1</sup> 4,299,000
Total.....	628,431,706	619,732,230	644,759,099	676,850,745	719,626,665

## IMPORTS.

Belgium.....	12,529,313	10,998,163	12,718,269	12,495,992	15,161,411
Brazil.....	5,451,072	4,122,609	4,944,999	<sup>2</sup> 4,944,999	<sup>2</sup> 4,944,999
British South Africa.....	7,533,108	7,445,086	4,512,895	3,645,416	4,155,799
Denmark.....	8,429,353	4,376,131	6,728,836	6,240,561	6,026,935
Dutch East Indies.....	3,807,433	3,239,235	3,553,612	3,888,939	<sup>1</sup> 4,278,796
Egypt.....	3,521,035	2,970,485	2,480,303	2,936,170	2,181,403
Finland.....	4,008,501	2,145,693	2,400,693	1,415,622	1,315,394
France.....	14,671,450	12,374,420	10,748,748	10,665,193	<sup>1</sup> 19,938,182
Germany.....	85,564,715	76,088,903	98,721,988	92,815,865	123,619,418
Netherlands.....	3,332,601	2,396,782	4,238,072	4,491,879	6,038,929
Russia.....	781,842	914,954	1,089,054	1,974,828	1,808,023
Sweden.....	1,498,438	275,626	398,499	205,352	343,029
Switzerland.....	7,914,073	8,211,694	9,283,130	11,062,683	12,097,742
United Kingdom.....	462,175,280	465,443,216	446,935,664	476,805,840	466,719,680
Other countries.....	17,245,000	15,208,000	19,863,000	21,779,000	<sup>1</sup> 29,508,000
Total.....	638,463,214	616,210,997	628,617,762	655,368,339	698,137,740

<sup>1</sup> Preliminary.<sup>2</sup> Data for 1909.

## BUTTER AND EGGS.

TABLE 150.—Average price received by farmers on the first of each month of 1912.

State and division.	Butter, cents per pound.												Eggs, cents per dozen.											
	Jan.	Feb.	Mar.	Apr.	May.	June.	July.	Aug.	Sept.	Oct.	Nov.	Dec.	Jan.	Feb.	Mar.	Apr.	May.	June.	July.	Aug.	Sept.	Oct.	Nov.	Dec.
Maine.....	31	31	32	31	30	29	29	29	30	31	32	32	38	32	32	22	22	21	23	25	29	31	36	42
New Hampshire.....	33	34	34	31	31	30	28	30	30	32	32	34	37	33	32	22	22	22	21	21	27	29	34	43
Vermont.....	34	37	33	32	32	31	28	29	30	31	32	34	37	32	31	22	20	20	23	25	29	35	41	41
Massachusetts.....	37	38	36	35	33	34	31	33	34	34	32	35	45	40	36	27	26	26	28	30	35	40	43	52
Rhode Island.....	35	39	39	34	34	36	32	32	35	34	34	34	47	39	39	26	24	25	27	32	36	35	43	53
Connecticut.....	36	39	38	35	34	35	33	34	34	36	34	36	42	41	36	24	24	24	27	29	34	36	45	50
New York.....	34	35	32	31	31	30	27	29	29	30	32	35	38	34	32	21	20	20	21	24	27	29	36	41
New Jersey.....	37	40	35	34	34	34	32	32	33	32	34	36	39	40	34	24	23	24	26	29	32	38	42	42
Pennsylvania.....	33	35	33	31	31	29	26	27	28	30	32	34	34	30	20	19	19	20	22	24	28	33	36	36
Delaware.....	29	32	31	32	30	28	26	25	25	25	25	33	30	31	28	18	18	20	22	22	28	30	37	37
Maryland.....	28	29	29	28	28	25	25	25	25	26	28	29	28	32	26	18	18	17	18	19	22	25	29	34
Virginia.....	25	26	26	26	25	23	21	22	22	24	26	26	27	28	24	17	16	16	17	18	19	22	25	29
West Virginia.....	26	26	26	26	26	22	21	21	22	24	25	27	28	27	26	17	17	17	18	19	19	22	25	29
North Carolina.....	24	25	25	23	24	23	23	23	22	24	24	25	24	23	21	15	15	15	15	16	17	19	21	26
South Carolina.....	25	26	27	25	27	27	26	24	25	26	26	27	26	25	23	19	18	19	18	20	23	24	28	28
Georgia.....	25	25	28	24	24	24	24	24	24	25	25	26	28	24	21	17	17	19	18	17	19	22	25	29
Florida.....	34	33	35	33	35	34	34	32	33	34	34	33	33	27	24	21	21	20	21	22	24	27	28	32
Ohio.....	27	28	27	25	25	24	22	23	24	25	27	29	30	30	26	18	17	17	17	18	20	23	28	32
Indiana.....	25	26	25	24	24	22	21	22	22	24	25	27	28	30	25	18	17	17	17	19	22	26	31	31
Illinois.....	27	28	26	25	25	24	24	23	24	26	26	28	29	30	25	18	17	16	16	18	22	25	28	28
Michigan.....	30	31	28	27	27	25	23	23	24	25	27	29	29	31	28	20	18	17	18	19	20	23	26	29
Wisconsin.....	33	34	28	28	29	26	25	25	26	27	28	31	30	29	27	18	17	16	17	19	21	25	28	28
Minnesota.....	31	32	29	27	27	27	24	24	25	26	28	30	29	29	26	17	16	16	16	18	20	25	27	27
Iowa.....	29	30	27	26	26	25	24	24	24	25	27	29	27	28	23	17	17	16	15	16	17	19	22	25
Missouri.....	23	23	23	23	23	22	21	21	21	22	23	24	25	27	22	16	16	15	14	14	16	18	22	25
North Dakota.....	27	27	25	23	23	22	20	20	22	24	28	28	31	30	26	16	16	15	15	16	17	20	25	28
South Dakota.....	29	28	26	24	25	23	21	22	22	24	27	29	30	28	24	17	16	16	15	16	17	19	23	26
Nebraska.....	26	26	24	24	23	22	21	21	22	23	25	27	27	27	22	17	16	15	14	14	15	18	23	26
Kansas.....	26	26	25	24	24	22	21	22	22	24	25	26	28	21	16	16	15	14	14	15	18	21	25	25
Kentucky.....	21	22	21	21	21	21	19	19	18	20	20	23	25	25	21	16	15	15	14	15	17	21	27	27
Tennessee.....	21	22	21	20	20	19	18	18	18	19	20	22	25	25	21	16	16	14	14	15	18	21	26	26
Alabama.....	24	22	22	22	21	21	20	21	21	22	24	25	22	19	15	15	16	15	14	16	20	22	25	25
Mississippi.....	23	23	22	23	22	22	21	22	21	23	22	23	24	23	19	17	15	15	16	16	20	20	24	24
Louisiana.....	28	30	28	27	28	27	26	27	27	28	30	26	24	20	16	14	14	15	16	17	19	23	24	24
Texas.....	22	25	23	22	21	21	21	20	21	23	23	24	26	25	18	14	14	15	14	14	15	17	21	23
Oklahoma.....	27	25	23	22	22	22	20	20	19	23	24	25	28	28	19	16	15	14	13	12	13	16	21	24
Arkansas.....	22	24	23	21	21	21	22	20	21	22	23	24	24	24	19	15	14	14	14	15	18	21	24	24
Montana.....	36	37	35	33	31	31	30	29	31	31	32	35	47	42	28	23	21	22	23	25	27	29	36	40
Wyoming.....	33	34	33	32	29	31	27	28	25	28	32	32	37	41	29	23	22	21	22	25	25	26	31	35
Colorado.....	33	33	30	30	28	28	26	26	28	28	32	31	37	34	27	24	20	19	20	22	24	26	32	34
New Mexico.....	36	36	35	35	33	35	31	30	30	30	34	33	39	34	30	26	22	25	21	25	27	29	32	32
Arizona.....	41	39	38	35	34	34	33	32	30	34	33	37	45	40	29	28	24	27	30	30	27	30	32	40
Utah.....	33	31	30	29	31	29	27	28	30	32	32	35	30	20	17	17	18	18	22	23	29	33	33	33
Nevada.....	34	38	34	36	36	32	31	34	36	35	36	38	49	40	36	29	29	32	30	34	39	40	42	42
Idaho.....	35	33	32	32	31	28	28	27	29	31	32	34	37	36	24	23	21	20	22	23	27	28	34	37
Washington.....	36	37	32	32	30	28	28	30	30	32	33	35	39	35	24	21	20	22	25	27	30	36	42	42
Oregon.....	34	35	33	32	31	26	28	28	30	30	35	36	38	34	25	21	20	19	19	23	26	27	36	40
California.....	34	36	34	32	30	29	29	31	31	33	34	36	40	34	21	20	19	19	20	24	26	32	37	44

## BUTTER.

	Jan.	Feb.	Mar.	Apr.	May.	June.	July.	Aug.	Sept.	Oct.	Nov.	Dec.
United States.....	28.1	29.0	27.2	26.1	26.0	24.8	23.4	23.7	24.2	25.6	26.9	28.3
North Atlantic.....	33.6	35.1	32.8	31.4	31.2	30.0	27.3	28.6	29.2	30.5	32.1	34.3
South Atlantic.....	25.4	26.1	26.7	25.3	25.5	23.7	23.0	23.0	23.1	24.7	25.5	26.6
N. C. E. Miss. R.....	28.2	29.2	26.8	25.7	25.9	24.2	22.9	23.0	23.9	25.3	26.6	28.8
N. C. W. Miss. R.....	27.3	27.6	25.7	24.8	24.7	23.6	22.2	22.4	22.8	24.1	25.9	27.5
South Central.....	22.5	23.6	22.3	21.7	21.2	21.0	20.4	19.9	20.1	21.7	22.1	23.7
Far Western.....	34.2	35.3	32.8	31.7	30.2	28.5	28.4	29.3	30.1	31.4	33.5	34.9

TABLE 150.—Average price received by farmers on the first of each month of 1912—Contd.

EGGS.

	Jan.	Feb.	Mar.	Apr.	May.	June.	July.	Aug.	Sept.	Oct.	Nov.	Dec.
United States.....	29.5	29.1	24.5	17.8	17.1	16.7	16.7	17.4	19.1	22.0	25.9	29.7
North Atlantic.....	37.3	34.9	31.9	21.5	20.7	20.6	21.7	24.3	27.1	30.3	35.9	40.7
South Atlantic.....	27.2	26.7	23.7	17.1	16.8	17.0	17.3	17.8	19.2	22.3	25.0	29.4
N. C. E. Miss. R.....	29.2	30.0	26.0	18.3	17.2	16.6	16.9	17.3	19.2	22.3	26.1	29.8
N. C. W. Miss. R.....	27.3	27.8	22.7	16.5	16.3	15.4	14.6	14.9	16.2	18.6	22.4	25.5
South Central.....	25.4	24.7	19.4	15.4	14.8	14.8	14.4	14.0	15.1	18.1	21.1	24.6
Far Western.....	39.2	34.6	23.4	21.1	19.6	19.6	20.5	23.6	25.8	29.4	35.2	40.5

TABLE 151.—Receipts of butter at seven leading markets in the United States, 1891-1912.

[From Board of Trade, Chamber of Commerce, and Merchants' Exchange Reports.]

[Quantities expressed in thousands, i. e., 000 omitted.]

Year.	Boston.	Chicago.	Mil- waukee.	St. Louis.	San Fran- cisco.	Total 5 cities.	Cincin- nati.	New York.
	<i>Pounds.</i>	<i>Pounds.</i>	<i>Pounds.</i>	<i>Pounds.</i>	<i>Pounds.</i>	<i>Pounds.</i>	<i>Packages.</i>	<i>Packages.</i>
1891.....	39,525	127,765	3,995	13,791	12,882	197,958	169	1,818
1892.....	39,888	133,197	3,896	13,402	14,677	205,060	76	1,699
1893.....	39,010	134,844	3,599	12,575	17,038	207,066	81	1,637
1894.....	39,565	144,868	4,261	14,139	17,257	220,090	91	1,714
1895.....	46,787	185,453	4,229	15,812	14,344	266,625	122	1,839
1896.....	50,972	237,795	4,848	16,122	13,770	323,507	136	2,189
1897.....	51,107	225,652	5,128	15,253	14,634	311,774	127	2,100
1898.....	50,610	222,628	5,372	14,906	15,606	309,122	139	1,952
1899.....	49,758	230,987	4,828	13,729	13,807	313,109	160	1,889
1900.....	51,503	244,385	5,304	12,901	14,564	328,657	223	1,922
1901.....	57,500	253,809	5,590	13,477	14,972	345,348	238	2,040
1902.....	54,574	219,233	7,290	14,573	14,801	310,471	223	1,933
1903.....	54,347	232,032	6,857	14,080	13,570	320,886	121	2,113
1904.....	55,435	249,024	7,993	15,727	14,336	342,515	147	2,170
1905.....	66,725	271,915	8,091	15,566	17,450	379,747	165	2,355
1906.....	65,152	248,648	8,209	13,198	9,282	344,489	205	2,242
1907.....	63,589	263,715	8,219	13,453	16,725	365,701	187	2,113
1908.....	69,843	316,695	8,798	18,614	13,528	427,478	166	2,175
1909.....	65,054	284,547	7,458	21,086	14,449	392,594	150	2,250
1910.....	69,421	318,986	7,319	23,163	13,922	432,811	135	2,257
1911.....	63,874	334,932	8,632	24,839	17,606	449,883	162	2,405
1912.....	72,109	286,213	7,007	20,521	28,172	414,022	109	2,436
<b>Averages:</b>								
1891-1895.....	40,955	145,225	3,996	13,944	15,240	219,360	88	1,741
1896-1900.....	50,790	232,289	5,096	14,582	14,476	317,234	157	2,010
1901-1905.....	57,716	245,203	7,164	14,685	15,026	339,793	177	2,122
1906-1910.....	66,612	286,518	8,001	17,903	13,581	392,615	169	2,207
<b>1912.</b>								
January.....	3,283	20,046	453	2,002	1,408	27,192	12	182
February.....	3,257	19,309	921	1,476	1,456	26,419	10	168
March.....	3,506	17,452	559	1,289	5,146	27,952	10	159
April.....	3,905	18,586	497	1,344	2,500	26,832	9	168
May.....	7,003	25,479	457	1,757	2,547	37,243	8	225
June.....	12,224	42,754	347	2,239	2,391	59,955	10	317
July.....	13,071	40,214	412	1,993	2,903	58,593	12	307
August.....	8,867	31,407	962	2,110	2,364	45,710	2	248
September.....	6,052	23,969	513	1,665	1,984	34,183	8	193
October.....	4,961	20,478	560	1,465	2,023	29,487	12	192
November.....	3,717	14,049	473	1,672	1,770	21,681	8	139
December.....	2,263	12,470	853	1,509	1,680	18,775	8	138

† Year beginning Sept. 1. Subsequent years are calendar years.

TABLE 152.—Receipts of eggs at seven leading markets in the United States, 1891-1912.

[From Board of Trade, Chamber of Commerce, and Merchants' Exchange Reports.]

Year.	Boston.	Chicago.	Cincinnati.	Milwaukee.	New York.	St. Louis.	San Francisco.	Total.
	<i>Cases.</i>	<i>Cases.</i>	<i>Cases.</i>	<i>Cases.</i>	<i>Cases.</i>	<i>Cases.</i>	<i>Cases.</i>	<i>Cases.</i>
1891.....	641,203	1,508,417	1,262,694	90,558	1,867,681	501,313	169,022	5,040,888
1892.....	688,227	1,955,696	272,661	80,395	2,022,008	469,216	176,964	5,665,167
1893.....	718,653	1,718,061	318,881	83,432	2,113,180	562,359	157,190	5,671,756
1894.....	781,918	2,097,179	321,011	97,557	2,323,511	598,773	162,712	6,382,661
1895.....	781,812	2,115,974	267,494	102,773	2,243,349	654,938	164,407	6,330,747
1896.....	875,518	2,301,499	361,265	106,565	2,633,932	796,490	164,732	7,240,001
1897.....	912,712	1,962,134	339,457	115,686	2,719,987	894,906	181,407	7,126,289
1898.....	889,216	2,147,950	306,423	115,652	2,542,090	898,984	203,380	7,103,695
1899.....	900,219	2,096,100	389,543	110,696	2,624,424	751,224	237,355	7,109,561
1900.....	986,367	2,475,473	414,623	118,036	2,799,937	920,682	183,563	7,898,681
1901.....	1,040,555	2,783,709	493,218	128,179	2,909,194	1,022,646	277,500	8,655,001
1902.....	1,053,165	2,659,340	464,799	114,732	2,743,642	825,999	285,058	8,146,735
1903.....	1,164,777	3,279,248	338,327	129,278	2,940,091	959,648	335,228	9,146,597
1904.....	1,122,819	3,113,858	377,263	166,409	3,215,924	1,216,124	319,637	9,532,034
1905.....	1,395,385	3,117,221	420,604	159,990	3,477,638	980,257	307,243	9,858,338
1906.....	1,709,531	3,583,878	484,208	187,561	3,981,013	1,023,125	137,074	11,106,390
1907.....	1,594,576	4,780,356	588,636	176,826	4,262,153	1,288,977	379,439	13,070,963
1908.....	1,436,786	4,569,914	441,072	207,558	3,703,990	1,439,868	347,436	12,145,724
1909.....	1,417,397	4,557,006	519,652	160,418	3,903,867	1,395,987	340,185	12,295,412
1910.....	1,431,686	4,844,045	511,519	169,448	4,380,777	1,375,638	469,698	13,182,811
1911.....	1,441,748	4,707,335	605,131	175,270	5,021,757	1,736,915	587,115	14,275,271
1912.....	1,580,106	4,556,643	668,942	136,621	4,723,558	1,391,611	638,920	13,696,401
<b>Averages:</b>								
1891-1895.....	722,363	1,879,065	288,548	90,943	2,113,946	557,320	166,059	5,818,244
1896-1900.....	912,807	2,196,631	362,262	113,327	2,664,074	852,457	194,087	7,295,645
1901-1905.....	1,155,340	2,990,675	418,842	139,718	3,057,298	1,000,939	304,833	9,067,741
1906-1910.....	1,517,995	4,467,040	509,017	180,362	4,046,360	1,304,719	334,766	12,300,259
<b>1912.</b>								
January.....	43,784	55,746	30,856	1,653	157,472	48,270	40,686	378,467
February.....	58,573	90,779	23,682	2,698	193,887	48,435	69,215	487,270
March.....	128,560	233,163	109,815	12,948	459,859	152,753	78,694	1,175,792
April.....	296,461	820,464	127,198	32,026	742,893	279,184	78,240	2,376,466
May.....	402,073	1,017,965	30,612	27,312	923,261	258,480	79,207	2,788,970
June.....	193,976	755,106	61,330	12,173	561,402	139,268	59,236	1,782,491
July.....	151,075	565,356	50,988	10,056	435,169	118,713	60,396	1,391,753
August.....	107,008	434,793	36,040	15,374	367,494	101,738	45,343	1,107,790
September.....	68,665	296,487	22,710	9,602	309,384	76,625	33,694	817,167
October.....	60,147	121,937	38,205	5,216	256,697	65,107	31,823	579,132
November.....	32,470	91,338	31,871	3,619	158,634	50,403	28,328	396,663
December.....	37,314	73,509	55,634	3,944	157,406	52,635	33,998	414,440

¹ Year beginning Sept. 1. Subsequent years are calendar years.

TABLE 153.—Wholesale price of eggs per dozen, 1899–1912.

Date.	Chicago.		Cincinnati.		St. Louis.		Milwaukee.		New York.	
	Fresh.				Average best fresh.		Fresh.		Average best fresh.	
	Low.	High.	Low.	High.	Low.	High.	Low.	High.	Low.	High.
	Cents.	Cents.	Cents.	Cents.	Cents.	Cents.	Cents.	Cents.	Cents.	Cents.
1899.....	10	35	8½	24	9	22	10	30	12½	35
1900.....	10	26	9	22	8	23	10	24	12	29
1901.....	10	28	9	27	6	25	10	24	13	31
1902.....	13½	32½	13	32	11½	32	13½	30	15½	37
1903.....	10	30	12	28	11	28½	12½	27	15	45
1904.....	11	34½	14½	32	13	29	13½	32	16	47
1905.....	12	36	14	30	10½	34	14	31	16½	45
1906.....	11	36	13	29	11½	26	12½	33	14½	40
1907.....	13	30	13½	29	12	25½	12½	28	16	50
1908.....	14	33	13	36	12½	29	13	32	15	55
1909.....										
January.....	24	36	28	36	26	38	15	30	29	40
February.....	20	35	21	37	21	40	16	32	24	40
March.....	17½	20½	17	20	16	18½	14	21	19	25
April.....	18½	20½	20	22	18	20	14	19½	20½	25
May.....	19	23	20	22	18	20	15	19½	22	26
June.....	17½	21½	19½	21½	17½	19	15	19½	21½	29
July.....	18	22½	20½	22½	17	19½	15	20½	23	32
August.....	19	23	20	23	17	19	15	20½	24	34
September.....	19	24	23	24	18	21	15	21½	25	37
October.....	20	27	23	28½	21	23½	15	24	25	50
November.....	23	30½	29	31½	23½	27	15	30	25	55
December.....	26½	36½	28	35	25½	31	15	34	30	53
Year.....	17½	36½	17	37	16	40	14	34	19	55
1910.....										
January.....	31	38	32½	40	28½	35	15	26	32	50
February.....	23½	31	23	30	22	26½	15	28	27	40
March.....	18½	24½	19½	22½	19	23	12	22	22	30
April.....	19½	22	19½	20½	19	20½	15	19	23	26
May.....	17½	20½	18	20	17	19½	13	18½	23	27
June.....	17½	19½	19	19½	14½	17½	12	17½	22	28
July.....	15	19½	17	19	15	17½	10	17½	23	33
August.....	15	22	18½	22½	17½	21	10	20	25	33
September.....	20	24	23½	24	21	23	10	23	25	40
October.....	23	27	25	29	21½	24	12	25	30	48
November.....	26	31	30	34½	24	27½	14	30	35	55
December.....	28	33	36	38	27	29½	15	30	36	55
Year.....	15	38	17	40	14½	35	10	30	22	55
1911.....										
January.....	18	32	18½	39	19	28	20	30	30	48
February.....	13	24	15	21	14½	20	15	24	19	36
March.....	13½	18	14½	17	13½	16½	13	17	17	28
April.....	13	17	14½	15½	13½	15½	13	15½	17	21
May.....	13	16½	13	15	12	15	12½	15	18	22
June.....	12	15	12½	16	11	13	11	13½	18	25
July.....	12	17	14½	16	12	15	12	16	19	30
August.....	13	18	16	19½	13½	17	14½	16	20	31
September.....	13½	20½	20½	22½	15½	18	14½	19	24	35
October.....	17	23	21½	28	18½	21	18	23	27	50
November.....	20	28	29½	38	21	29	20	30	30	57
December.....	22	30	30	38	24	20	26	32	35	60
Year.....	12	32	12½	39	11	29	11	32	17	60
1912.....										
January.....	29	37	27	37	26	39	22	32	34	41
February.....	26½	40	23½	40	24½	29	25	38	28	48
March.....	19½	23	18½	22	19	21½	17½	27	22	30
April.....	18	20	18½	20	17½	19½	16½	19½	21	25
May.....	17	18	17½	18	16	17½	15	17	20½	24
June.....	17	18½	17	19	16	17	15	17	21	27
July.....	17½	18	18	19	14½	17	16	18	23	31
August.....	18	20	18	22	15½	19½	16	19	24	32
September.....	20	23	22	26	19½	22	17½	22	27	42
October.....	23	24½	25	30	22	23½	19	26	34	55
November.....	25	27	31½	36	23½	26	23	29	40	60
December.....	23	27½	26	34	22	27	20	30	30	55
Year.....	17	40	17	40	14½	39	15	38	20½	60

CHICKENS.

TABLE 154.—Average price per pound received by farmers on first of months indicated.

State and division.	1911						1912											
	Feb.	Apr.	June.	Aug.	Oct.	Dec.	Jan.	Feb.	Mar.	Apr.	May.	June.	July.	Aug.	Sept.	Oct.	Nov.	Dec.
	Cts.	Cts.	Cts.	Cts.	Cts.	Cts.	Cts.	Cts.	Cts.	Cts.	Cts.	Cts.	Cts.	Cts.	Cts.	Cts.	Cts.	Cts.
Maine.....	14.8	13.7	15.0	15.3	14.7	13.5	13.7	13.0	14.0	14.5	15.0	15.0	14.5	16.0	13.5	14.0	15.0	14.2
New Hampshire.....	13.9	14.5	14.3	14.8	15.7	14.0	14.0	14.0	14.6	14.2	14.5	15.0	13.5	16.0	13.4	13.8	13.8	14.3
Vermont.....	12.5	13.2	13.5	12.7	14.5	11.8	11.1	12.5	12.2	13.4	13.4	13.2	12.5	12.7	12.8	12.7	13.0	14.0
Massachusetts.....	16.6	16.3	17.0	17.0	16.2	16.0	15.7	16.0	15.1	16.0	16.2	17.0	16.0	17.5	16.6	15.8	15.6	16.4
Rhode Island.....	15.7	19.3	17.3	17.0	16.2	15.0	14.3	16.0	17.0	16.7	16.0	16.1	12.0	18.2	18.5	18.0	17.2	15.8
Connecticut.....	15.1	15.8	16.0	16.8	16.4	15.0	15.3	15.4	15.4	15.6	15.3	16.3	17.2	15.8	15.6	16.0	15.8	17.0
New York.....	13.6	14.3	14.2	15.3	14.2	12.5	12.5	13.1	13.6	14.0	14.3	14.5	14.8	14.9	15.0	14.4	14.1	13.5
New Jersey.....	16.3	16.6	16.5	16.3	16.7	14.6	14.6	15.0	16.1	15.6	16.0	18.0	16.8	16.8	17.0	17.3	16.9	16.5
Pennsylvania.....	12.7	13.3	13.2	14.1	13.3	11.0	11.4	15.2	12.6	12.6	13.5	13.0	13.7	13.6	13.3	13.3	12.8	12.5
N. Atlantic.....	13.8	14.3	14.3	15.0	14.4	12.5	12.7	13.2	13.7	13.8	14.3	14.6	14.7	14.8	14.5	14.3	14.0	13.8
Delaware.....	11.7	13.0	13.5	13.7	13.0	11.0	11.0	13.0	13.0	13.5	14.0	15.0	14.7	13.3	15.0	16.0	12.0	13.0
Maryland.....	13.4	14.2	14.6	15.2	13.6	11.5	12.0	12.3	13.0	13.4	13.5	14.4	14.2	15.0	13.5	14.0	14.0	13.5
Virginia.....	12.6	12.9	13.7	14.3	13.3	11.6	11.8	11.7	12.2	12.4	12.8	13.2	12.8	13.3	13.0	13.7	13.2	13.3
West Virginia.....	11.4	11.7	11.7	12.9	12.4	10.6	10.8	10.7	11.4	11.0	11.4	11.8	11.9	12.5	12.4	12.3	12.5	11.7
North Carolina.....	10.8	11.0	12.0	12.4	11.5	10.5	10.1	10.3	10.4	10.7	11.0	12.0	11.8	12.2	11.1	11.2	11.5	10.8
South Carolina.....	11.1	13.1	11.4	13.0	12.4	12.0	12.8	11.1	12.5	11.7	11.8	13.0	12.8	12.6	12.3	11.9	12.5	13.0
Georgia.....	12.0	12.7	13.5	12.4	13.0	12.5	12.7	11.8	12.4	12.3	13.0	13.4	13.4	12.7	12.8	13.0	13.5	13.3
Florida.....	12.8	13.0	13.0	14.1	13.6	15.5	14.2	15.2	12.8	15.0	13.9	15.0	15.2	15.6	15.0	16.1	14.5	15.0
S. Atlantic.....	11.9	11.5	12.8	13.3	12.7	11.7	11.8	12.6	12.0	12.0	12.4	13.1	12.9	13.1	12.9	13.2	12.9	12.8
Ohio.....	10.2	11.2	11.2	11.3	10.7	8.8	8.8	10.0	10.7	11.2	11.5	11.3	10.6	11.1	11.5	11.7	11.5	10.8
Indiana.....	10.1	10.1	10.2	10.3	10.2	8.5	8.7	9.5	10.2	10.9	10.8	10.7	10.2	11.0	10.8	11.0	10.9	10.2
Illinois.....	9.9	10.2	10.1	10.4	10.2	8.9	9.0	9.6	9.8	10.8	10.6	10.6	10.6	10.6	11.1	11.0	10.6	10.2
Michigan.....	10.5	10.9	10.7	10.7	10.5	8.7	9.0	10.0	10.5	11.2	11.4	11.2	10.8	10.7	11.0	11.1	11.2	10.5
Wisconsin.....	10.5	10.8	10.8	11.5	10.9	9.0	9.5	10.2	10.4	10.9	11.4	11.3	10.9	12.0	11.9	10.8	11.1	9.3
N. C. E. Miss. R.....	10.2	10.7	10.6	10.8	10.5	8.8	9.0	9.8	10.3	11.0	11.1	11.0	10.6	11.0	11.2	11.3	11.0	10.4
Minnesota.....	9.0	9.2	9.1	9.8	9.1	8.0	8.4	8.6	9.1	9.5	9.8	9.4	9.7	9.1	10.0	9.7	9.5	9.1
Iowa.....	8.7	8.9	9.0	9.4	9.4	7.8	8.2	8.9	9.1	9.5	9.7	9.4	9.5	9.9	10.0	10.3	9.6	9.3
Missouri.....	9.2	9.9	9.9	9.9	9.5	7.7	8.0	9.0	9.4	10.0	10.1	10.3	10.2	10.6	10.4	10.6	9.8	9.6
North Dakota.....	8.7	9.4	9.5	9.7	8.7	8.5	9.3	9.3	9.6	9.4	9.8	9.7	9.2	9.5	9.8	9.7	10.0	9.5
South Dakota.....	9.2	8.5	8.5	8.9	8.5	8.0	8.4	7.9	9.0	8.3	8.6	8.7	8.8	9.3	8.9	9.2	9.8	9.0
Nebraska.....	8.4	8.6	8.6	9.0	8.6	7.7	8.0	8.3	7.9	10.0	9.3	9.0	9.3	9.4	9.7	10.0	9.5	9.0
Kansas.....	8.7	8.8	8.9	8.7	8.5	7.5	8.1	8.2	8.8	8.9	9.1	8.9	8.6	9.0	9.0	9.5	9.4	8.6
N. C. W. Miss. R.....	8.8	9.1	9.1	9.4	9.1	7.8	8.2	8.7	9.0	9.5	9.6	9.4	9.5	9.7	9.8	10.1	9.6	9.2
Kentucky.....	10.1	10.5	10.8	10.9	10.2	8.3	8.4	9.4	9.7	10.4	10.0	10.4	10.6	10.8	10.4	10.9	10.5	10.0
Tennessee.....	9.9	10.4	10.4	11.0	10.2	9.1	9.1	9.7	10.0	10.1	10.6	10.4	10.6	10.6	10.7	10.9	10.7	10.1
Alabama.....	12.0	11.0	10.8	11.6	12.3	12.0	12.4	11.6	10.5	11.0	11.4	11.0	11.5	11.3	11.8	11.9	12.0	13.0
Mississippi.....	11.1	11.1	12.2	11.6	11.8	11.2	12.3	11.2	11.3	11.0	11.1	11.3	11.5	11.3	11.5	12.0	12.1	11.7
Louisiana.....	13.0	12.8	13.8	12.5	13.8	13.5	14.0	13.5	13.2	11.5	12.8	12.2	12.2	14.0	13.5	14.3	12.9	12.2
Texas.....	8.9	9.1	9.3	9.5	9.3	9.0	8.4	8.8	8.7	8.4	8.9	8.9	9.4	9.4	9.4	9.7	9.8	9.4
Oklahoma.....	8.9	8.8	9.0	9.1	8.7	7.6	7.8	8.1	8.0	8.6	8.8	8.6	8.3	8.3	8.7	9.1	9.0	8.5
Arkansas.....	10.3	9.8	10.0	9.5	9.6	8.8	7.6	9.0	9.3	9.0	9.5	9.4	9.8	10.0	9.6	9.7	9.6	9.2
S. Central.....	10.2	10.2	10.5	10.5	10.4	9.6	9.6	9.8	9.8	9.7	10.1	10.0	10.3	10.4	10.4	10.8	10.6	10.3
Montana.....	15.2	15.3	14.8	14.6	13.8	13.5	14.2	14.2	14.2	14.0	13.0	13.8	14.3	14.5	13.2	14.5	13.8	12.9
Wyoming.....	13.8	15.9	13.5	15.0	15.7	14.5	14.8	14.5	14.2	9.0	12.0	14.0	16.0	16.2	13.2	15.0	13.6	13.3
Colorado.....	13.1	12.9	12.7	14.1	13.6	11.5	12.5	12.6	13.0	13.2	12.8	12.9	13.3	13.1	13.4	12.0	13.3	12.0
New Mexico.....	13.4	13.2	12.5	14.2	12.7	15.0	16.0	14.8	15.8	13.8	11.6	15.0	12.0	13.0	13.5	13.0	14.0	13.0
Arizona.....	20.7	18.7	17.0	15.9	19.7	17.6	16.5	16.5	16.0	15.7	13.8	15.0	13.3	16.0	13.1	13.7	14.4	14.0
Utah.....	13.2	11.5	12.5	13.2	12.5	12.0	12.5	11.3	11.4	12.1	12.4	12.7	12.3	11.4	12.2	12.3	13.8	13.0
Nevada.....	15.7	16.2	12.9	15.4	19.1	18.0	20.1	18.7	16.8	18.9	18.9	22.5	20.6	16.5	20.0	20.9	18.2	18.5
Idaho.....	14.6	14.2	12.6	12.1	12.0	11.4	9.3	9.9	12.0	12.6	11.7	12.5	12.0	11.5	11.9	11.7	12.2	11.5
Washington.....	13.8	14.8	15.0	13.7	13.9	12.5	12.6	12.2	12.8	13.0	13.2	13.6	13.0	13.1	13.3	13.2	13.6	12.5
Oregon.....	13.3	14.4	14.5	13.5	13.5	12.3	12.8	12.8	12.2	12.6	12.2	12.2	12.0	11.9	12.0	11.9	12.4	12.3
California.....	15.0	15.6	14.7	14.8	15.3	15.0	14.8	14.3	14.7	14.1	14.3	13.8	14.4	14.2	13.9	14.1	14.2	14.4
Far Western.....	14.4	14.8	14.3	14.2	14.4	13.6	13.7	13.3	13.7	14.4	13.4	13.4	13.5	13.4	13.2	13.3	13.6	13.3
United States.....	10.6	10.8	11.0	11.2	10.9	9.6	9.8	10.3	10.5	10.8	11.1	11.1	11.0	11.3	11.3	11.5	11.2	10.8

CHEESE.

TABLE 155.—International trade in cheese, calendar years 1907–1911.

Cheese includes all cheese made from milk; "cottage cheese," of course, is included. See "General note," p. 564.]

EXPORTS.

Country.	1907	1908	1909	1910	1911
	<i>Pounds.</i>	<i>Pounds.</i>	<i>Pounds.</i>	<i>Pounds.</i>	<i>Pounds.</i>
Bulgaria.....	5,674,114	5,598,083	5,218,136	7,091,257	7,549,046
Canada.....	189,381,875	•172,081,891	177,259,042	186,665,789	169,179,147
France.....	25,584,279	24,272,205	26,103,125	25,160,659	1 28,620,779
Germany.....	2,891,774	3,387,809	2,381,409	1,858,257	2,178,806
Italy.....	46,606,567	43,711,045	44,054,742	57,516,250	61,403,181
Netherlands.....	113,646,865	118,252,531	124,070,366	122,771,456	113,607,416
New Zealand.....	26,525,296	31,449,376	44,867,984	50,614,480	49,187,488
Russia.....	3,337,003	3,758,259	4,817,773	5,463,650	8,945,249
Switzerland.....	62,212,710	67,653,883	69,217,606	69,391,549	66,593,470
United States.....	10,341,335	10,190,843	3,501,214	2,768,681	13,781,176
Other countries.....	8,336,000	8,295,000	8,545,000	10,441,000	1 10,369,000
Total.....	494,537,818	488,650,925	510,036,397	539,743,028	531,414,758

IMPORTS.

Algeria.....	6,232,625	6,184,344	1 6,504,960	1 6,420,898	1 6,182,360
Argentina.....	7,265,674	8,085,617	8,884,664	9,535,944	10,845,391
Australia.....	299,711	566,808	367,504	303,155	318,891
Austria-Hungary.....	9,118,667	9,748,741	10,483,755	12,536,899	12,473,406
Belgium.....	32,278,673	31,051,052	30,523,564	31,494,724	29,641,555
Brazil.....	3,632,054	3,455,087	3,241,214	3 3,241,214	3 3,241,214
British South Africa.....	4,761,140	4,459,453	4,329,228	4,726,520	5,039,056
Cuba.....	5,232,438	4,147,120	4,106,493	4,807,741	2 4,807,741
Denmark.....	1,784,624	1,686,519	1,739,429	1,357,813	1,203,491
Egypt.....	8,650,769	9,072,687	8,947,118	9,229,798	8,927,907
France.....	46,137,240	50,010,690	47,420,285	49,011,344	1 49,422,723
Germany.....	44,760,435	45,689,233	46,292,191	46,011,104	45,954,440
Italy.....	10,293,939	16,953,154	17,438,827	14,760,899	11,915,422
Russia.....	3,612,869	3,437,180	3,476,651	3,671,083	4,008,310
Spain.....	4,398,812	4,531,068	4,422,370	4,882,058	4,929,248
Switzerland.....	7,048,547	6,564,637	6,041,045	6,308,683	7,643,789
United Kingdom.....	259,833,392	251,908,608	261,227,232	267,878,240	257,133,744
United States.....	34,238,459	33,793,726	37,795,506	43,967,273	45,447,329
Other countries.....	14,521,000	13,567,000	15,816,000	18,167,000	1 18,550,000
Total.....	504,101,068	504,912,724	519,058,036	538,312,390	527,686,523

1 Preliminary.

2 Year preceding.

3 Data for 1909.

SHEEP AND WOOL.

TABLE 156.—Number and value of sheep on farms in the United States, 1867–1913.

Year.	Number.	Price per head Jan. 1.	Farm value Jan. 1.	Year.	Number.	Price per head Jan. 1.	Farm value Jan. 1.
1867.....	39,385,000	\$2.50	\$98,644,000	1882.....	45,016,000	\$2.37	\$106,596,000
1868.....	38,992,000	1.82	71,053,000	1883.....	49,237,000	2.53	124,366,000
1869.....	37,724,000	1.64	62,037,000	1884.....	50,627,000	2.37	119,903,000
1870.....	40,853,000	1.96	79,876,000	1885.....	50,360,000	2.14	107,961,000
1871.....	31,851,000	2.14	68,310,000	1886.....	48,322,000	1.91	92,444,000
1872.....	31,679,000	2.61	82,768,000	1887.....	44,759,000	2.01	89,873,000
1873.....	33,002,000	2.71	89,427,000	1888.....	43,545,000	2.05	89,280,000
1874.....	33,938,000	2.43	82,353,000	1889.....	42,599,000	2.13	90,640,000
1875.....	33,784,000	2.55	86,278,000	1890.....	44,336,000	2.27	100,660,000
1876.....	35,935,000	2.37	85,121,000	1891.....	43,431,000	2.50	108,397,000
1877.....	35,804,000	2.13	76,362,000	1892.....	44,938,000	2.58	116,121,000
1878.....	35,740,000	2.21	78,898,000	1893.....	47,274,000	2.66	125,909,000
1879.....	38,124,000	2.07	78,965,000	1894.....	45,048,000	1.98	89,186,000
1880.....	40,766,000	2.21	90,231,000	1895.....	42,294,000	1.58	66,686,000
1881.....	43,570,000	2.30	104,071,000	1896.....	38,299,000	1.70	65,168,000



TABLE 156.—Number and value of sheep on farms in the United States, 1867–1913—Con.

Year.	Number.	Price per head Jan. 1.	Farm value Jan. 1.	Year.	Number.	Price per head Jan. 1.	Farm value Jan. 1.
1897.....	36,819,000	\$1.82	\$67,021,000	1906.....	50,632,000	\$3.54	\$179,056,000
1898.....	37,657,000	2.46	92,721,000	1907.....	53,240,000	3.84	204,210,000
1899.....	39,114,000	2.75	107,698,000	1908.....	54,631,000	3.88	211,736,000
1900.....	41,883,000	2.93	122,666,000	1909.....	56,084,000	3.43	192,632,000
1901 <sup>1</sup> .....	59,757,000	2.98	178,072,000	1910.....	57,216,000	4.08	233,664,000
1902.....	62,039,000	2.65	164,446,000	1911 <sup>1</sup> .....	53,633,000	3.91	209,535,000
1903.....	63,965,000	2.63	168,316,000	1912.....	52,362,000	3.46	181,170,000
1904.....	51,630,000	2.59	133,530,000	1913.....	51,482,000	3.94	202,779,000
1905.....	45,170,000	2.82	127,332,000				

<sup>1</sup> Estimates of numbers revised, based on census data; see Table 140, p. 677.

TABLE 157.—Number and value of sheep on farms, by States, Jan. 1, 1912 and 1913.

State and division.	Number Jan. 1. <sup>1</sup>		Average farm price per head Jan. 1.		Farm value Jan. 1.	
	1913	1912	1913	1912	1913	1912
Maine.....	186	186	\$4.20	\$4.10	\$781	\$763
New Hampshire.....	42	43	4.90	4.30	206	185
Vermont.....	117	117	4.60	4.30	538	503
Massachusetts.....	34	35	4.80	4.80	163	168
Rhode Island.....	7	7	5.10	4.60	36	32
Connecticut.....	21	21	5.20	4.60	109	97
New York.....	875	911	5.00	4.40	4,375	4,008
New Jersey.....	31	30	5.30	5.20	164	156
Pennsylvania.....	865	883	5.00	4.30	4,325	3,797
North Atlantic.....	2,178	2,233	4.91	4.35	10,697	9,709
Delaware.....	8	8	4.70	4.30	38	34
Maryland.....	225	230	4.60	4.40	1,035	1,012
Virginia.....	750	781	4.00	3.60	3,000	2,812
West Virginia.....	821	838	4.30	3.90	3,530	3,268
North Carolina.....	181	193	3.10	2.80	561	540
South Carolina.....	34	34	2.80	2.80	95	95
Georgia.....	169	174	1.90	2.00	321	348
Florida.....	119	120	2.10	2.10	250	252
South Atlantic.....	2,307	2,378	3.83	3.52	8,830	8,361
Ohio.....	3,435	3,694	4.10	3.40	14,084	12,560
Indiana.....	1,317	1,372	4.60	4.20	6,058	5,762
Illinois.....	1,036	1,068	5.10	4.40	5,284	4,699
Michigan.....	2,139	2,276	4.30	3.60	9,198	8,194
Wisconsin.....	822	847	4.50	3.90	3,699	3,303
North Central East of Mississippi River.....	8,749	9,257	4.38	3.73	38,323	34,518
Minnesota.....	570	600	4.40	3.60	2,508	2,160
Iowa.....	1,249	1,201	5.10	4.30	6,370	5,164
Missouri.....	1,650	1,755	4.20	3.80	6,930	6,699
North Dakota.....	293	287	3.90	3.60	1,143	1,033
South Dakota.....	593	605	4.10	3.30	2,431	1,999
Nebraska.....	382	382	4.40	3.60	1,681	1,375
Kansas.....	316	326	4.60	3.80	1,454	1,239
North Central West of Mississippi River.....	5,053	5,156	4.46	3.81	22,517	19,636
Kentucky.....	1,320	1,320	4.00	3.70	5,280	4,884
Tennessee.....	724	762	3.10	3.00	2,244	2,286
Alabama.....	132	140	2.10	2.20	277	308
Mississippi.....	208	214	2.20	2.20	458	471
Louisiana.....	171	176	2.00	2.00	342	352
Texas.....	2,073	2,032	2.90	2.80	6,012	5,690
Oklahoma.....	71	72	3.60	3.30	256	238
Arkansas.....	130	134	2.40	2.30	312	308
South Central.....	4,829	4,850	3.14	3.00	15,181	14,537

<sup>1</sup> Expressed in thousands; 000 omitted.

TABLE 157.—Number and value of sheep on farms, by States, Jan. 1, 1912 and 1913—Continued.

State and division.	Number Jan. 1 <sup>1</sup>		Average farm price per head Jan. 1.		Farm value Jan. 1. <sup>1</sup>	
	1913	1912	1913	1912	1913	1912
Montana.....	5,111	5,011	\$3.70	\$3.30	\$18,911	\$16,536
Wyoming.....	4,472	4,969	4.10	2.80	18,335	13,913
Colorado.....	1,737	1,579	3.60	3.00	6,253	4,737
New Mexico.....	3,300	3,300	3.10	2.80	10,230	9,240
Arizona.....	1,570	1,510	3.70	4.30	5,809	6,493
Utah.....	1,990	1,990	4.10	3.80	8,159	7,562
Nevada.....	1,487	1,444	4.00	3.80	5,948	5,487
Idaho.....	2,951	2,951	4.00	3.60	11,804	10,624
Washington.....	501	486	4.20	3.50	2,104	1,701
Oregon.....	2,644	2,592	3.80	3.30	10,047	8,554
California.....	2,603	2,656	3.70	3.60	9,631	9,562
Far Western.....	28,366	28,488	3.78	3.31	107,231	94,409
United States.....	51,482	52,362	3.94	3.46	202,779	181,170

<sup>1</sup> Expressed in thousands; 000 omitted.

TABLE 158.—Imports, exports, and average prices of sheep, 1892-1912.

Year ending June 30—	Imports.			Exports.		
	Number.	Value.	Average import price.	Number.	Value.	Average export price.
1892.....	380,814	\$1,440,530	\$3.78	46,960	\$161,105	\$3.43
1893.....	459,484	1,682,977	3.66	37,260	126,394	3.39
1894.....	242,568	788,181	3.25	132,370	832,763	6.29
1895.....	291,461	682,618	2.34	405,748	2,630,686	6.48
1896.....	322,692	853,530	2.65	491,565	3,076,384	6.26
1897.....	405,633	1,019,668	2.51	244,120	1,531,645	6.27
1898.....	392,314	1,106,322	2.82	199,690	1,213,886	6.08
1899.....	345,911	1,200,081	3.47	143,286	853,555	5.96
1900.....	381,792	1,365,026	3.58	125,772	733,477	5.83
1901.....	331,488	1,236,277	3.73	297,925	1,933,000	6.49
1902.....	266,953	956,710	3.58	358,720	1,940,060	5.41
1903.....	301,623	1,036,934	3.44	176,961	1,067,860	6.03
1904.....	238,094	815,289	3.42	301,313	1,954,604	6.49
1905.....	186,942	704,721	3.77	268,365	1,687,321	6.29
1906.....	240,747	1,020,359	4.24	142,690	804,090	5.64
1907.....	224,798	1,120,425	4.98	135,344	750,242	5.54
1908.....	224,765	1,082,606	4.82	101,000	589,285	5.83
1909.....	102,663	502,640	4.90	67,656	365,155	5.40
1910.....	126,152	696,879	5.52	44,517	209,000	4.69
1911.....	53,455	377,625	7.06	121,491	636,272	5.24
1912.....	23,588	157,257	6.67	157,263	626,985	3.99

TABLE 159.—Wholesale price of sheep per 100 pounds, 1899–1912.

Date.	Chicago.		Cincinnati.		St. Louis.		Kansas City.	
	Inferior to choice.		Good to extra.		Good to choice natives.		Native.	
	Low.	High.	Low.	High.	Low.	High.	Low.	High.
1899.....	\$2.50	\$5.65	\$3.00	\$5.00	\$3.00	\$5.60	\$2.25	\$5.85
1900.....	2.00	6.50	1.25	6.00	3.40	6.25	2.75	6.50
1901.....	2.50	5.15	2.10	5.00	3.00	5.10	1.50	5.00
1902.....	1.25	6.50	2.50	5.75	3.65	6.35	2.00	6.50
1903.....	1.25	7.00	2.60	6.25	3.50	6.25	2.25	6.80
1904.....	1.50	6.00	2.75	4.60	3.75	5.65	2.00	6.00
1905.....	3.80	6.30	3.60	5.50	4.60	6.35	2.75	6.90
1906.....	3.00	7.00	3.85	5.75	5.00	6.45	2.50	6.75
1907.....	2.00	7.25	3.65	5.90	4.25	7.00	2.25	7.75
1908.....	2.00	7.00	2.75	5.50	4.10	6.90	1.50	7.15
1909.								
January.....	2.50	5.50	3.50	5.25	4.25	6.00	2.50	6.75
February.....	2.00	5.50	4.50	5.25	5.40	6.25	2.00	7.00
March.....	3.00	5.75	4.50	5.75	5.50	6.50	2.00	7.10
April.....	3.50	6.50	4.75	5.75	6.15	6.50	3.00	7.65
May.....	3.00	6.90	4.35	5.25	6.35	6.65	3.50	7.50
June.....	2.50	6.75	3.50	5.25	5.25	6.50	4.00	8.00
July.....	2.50	5.50	3.35	4.50	4.25	5.00	2.25	5.50
August.....	2.00	5.00	3.75	4.50	4.50	5.00	2.25	5.50
September.....	2.00	5.25	3.50	4.50	4.50	5.00	2.00	5.25
October.....	2.00	5.00	3.35	4.25	4.75	5.00	2.00	5.15
November.....	2.00	5.50	3.60	4.50	4.35	5.00	3.25	7.00
December.....	2.50	6.00	3.75	5.50	5.15	6.25	3.50	7.25
Year.....	2.00	6.90	3.35	5.75	4.25	6.65	2.00	8.00
1910.								
January.....	3.25	6.30	4.75	6.00	6.00	6.30	4.00	7.65
February.....	4.00	7.90	5.25	6.50	6.10	7.25	5.50	8.25
March.....	5.00	9.30	6.00	6.75	7.00	8.50	6.00	9.50
April.....	4.00	8.40	6.00	7.00	8.00	8.75	6.00	9.00
May.....	4.25	7.65	4.50	6.50	5.75	8.30	4.50	8.00
June.....	3.75	6.25	3.60	5.25	5.00	6.00	4.00	7.15
July.....	2.50	5.00	3.00	4.25	4.25	4.60	3.85	6.50
August.....	3.00	4.65	3.25	4.25	4.25	4.50	3.00	5.50
September.....	3.00	4.65	3.25	4.25	4.35	4.75	3.50	6.25
October.....	2.75	4.45	3.15	4.25	4.25	4.50	3.25	6.00
November.....	2.00	4.50	3.00	4.15	3.75	4.20	2.00	5.25
December.....	2.85	4.50	3.25	4.00	4.10	4.25	2.55	5.75
Year.....	2.00	9.30	3.00	7.00	3.75	8.75	2.00	9.50
1911.								
January.....	2.50	<sup>(1)</sup> 6.65	3.50	4.50	4.25	4.50	2.50	5.75
February.....	2.50	6.50	3.25	4.25	4.15	4.75	2.50	4.75
March.....	3.25	6.65	3.75	5.15	4.65	5.00	4.00	5.10
April.....	3.00	6.60	3.35	4.50	4.05	5.00	4.00	5.00
May.....	2.75	7.85	3.25	4.00	4.35	4.85	3.00	6.25
June.....	2.00	7.40	2.55	4.00	3.50	4.90	2.50	5.60
July.....	2.00	7.55	2.75	3.50	3.75	4.20	2.50	5.25
August.....	2.00	7.40	2.50	3.50	3.50	4.50	2.00	4.50
September.....	2.25	6.40	2.50	3.50	3.65	4.00	2.00	4.40
October.....	1.75	6.40	2.50	3.50	4.00	4.25	2.25	5.00
November.....	1.50	6.50	2.40	3.25	4.00	4.15	1.50	4.25
December.....	1.75	6.40	2.50	3.50	4.00	4.50	1.75	4.50
Year.....	1.50	7.85	2.40	5.15	3.50	5.00	1.50	6.25
1912.								
January.....	2.50	5.10	3.00	4.00	4.35	4.40	3.35 <sup>(2)</sup>	6.00
February.....	2.75	5.00	3.10	3.75	4.00	4.65	3.30	5.55
March.....	3.50	6.35	3.25	4.75	4.25	5.50	4.50	6.60
April.....	3.85	7.50	4.25	5.50	5.40	6.40	5.50	7.75
May.....	4.00	7.50	4.25	5.50	5.25	7.00	4.00	8.00
June.....	2.75	5.75	3.00	4.65	4.25	5.40	4.00	6.50
July.....	2.75	5.50	3.00	4.00	4.25	4.25	3.75	5.80
August.....	2.50	4.85	2.85	3.80	3.75	4.75	3.50	5.35
September.....	2.75	4.80	2.85	3.50	4.00	5.00	3.60	5.45
October.....	2.00	4.75	3.00	3.75	3.95	4.85	3.35	5.35
November.....	2.00	4.65	3.25	3.85	4.15	4.40	3.50	6.00
December.....	3.00	5.65	3.35	4.00	4.25	4.75	4.25	7.35
Year.....	2.00	7.50	2.85	5.50	3.75	7.00	3.30	8.00

<sup>1</sup> Includes yearlings and lambs.<sup>2</sup> Not including lambs.

TABLE 160.—Wool product of the United States.

[Estimates of National Association of Wool Manufacturers.]

State and year.	Number of sheep of shearing age Apr. 1, 1912.	Average weight of fleece.	Per cent of shrinkage.	Wool washed and unwashed. <sup>1</sup>	Wool scoured. <sup>1</sup>
	<i>Number.</i>	<i>Pounds.</i>	<i>Per cent.</i>	<i>Pounds.</i>	<i>Pounds.</i>
Maine.....	150,000	6.25	42	937,500	543,750
New Hampshire.....	33,000	6.50	43	214,500	111,540
Vermont.....	90,000	6.75	50	607,500	303,750
Massachusetts.....	23,000	6.25	42	143,750	83,375
Rhode Island.....	5,000	6.00	42	30,000	17,400
Connecticut.....	15,000	5.70	42	85,500	49,590
New York.....	625,000	6.00	48	3,750,000	1,950,000
New Jersey.....	17,000	5.40	45	91,800	50,490
Pennsylvania.....	650,000	6.30	47	4,095,000	2,170,350
Delaware.....	5,000	5.30	44	26,500	14,840
Maryland.....	128,000	5.70	44	729,600	408,576
Virginia.....	450,000	4.50	36	2,025,000	1,296,000
West Virginia.....	575,000	5.50	48	3,162,500	1,644,500
North Carolina.....	150,000	3.75	42	562,500	326,250
South Carolina.....	30,000	3.60	42	108,000	62,640
Georgia.....	175,000	3.75	43	656,250	374,063
Florida.....	95,000	3.25	38	308,750	191,425
Ohio.....	2,700,000	6.25	49	16,875,000	8,606,250
Indiana.....	825,000	6.40	45	5,280,000	2,904,000
Illinois.....	675,000	6.75	47	4,556,250	2,414,813
Michigan.....	1,500,000	6.75	48	10,125,000	5,265,000
Wisconsin.....	650,000	6.60	46	4,290,000	2,316,600
Minnesota.....	450,000	6.75	47	3,037,500	1,609,875
Iowa.....	850,000	6.75	48	5,737,500	2,983,500
Missouri.....	1,100,000	6.75	45	7,425,000	4,083,750
North Dakota.....	250,000	7.00	60	1,750,000	700,000
South Dakota.....	475,000	6.75	62	3,206,250	1,218,375
Nebraska.....	275,000	6.40	62	1,760,000	668,800
Kansas.....	225,000	7.00	65	1,575,000	551,250
Kentucky.....	775,000	4.60	37	3,565,000	2,245,950
Tennessee.....	475,000	4.00	40	1,900,000	1,140,000
Alabama.....	115,000	3.25	38	373,750	231,725
Mississippi.....	150,000	3.75	39	562,500	343,125
Louisiana.....	140,000	3.75	39	525,000	320,250
Texas.....	1,400,000	6.50	66	9,100,000	3,094,000
Oklahoma.....	60,000	6.50	67	390,000	128,700
Arkansas.....	100,000	4.00	40	400,000	240,000
Montana.....	4,300,000	7.25	62	31,175,000	11,846,500
Wyoming.....	3,900,000	8.25	67	32,175,000	10,617,750
Colorado.....	1,200,000	6.70	67	8,040,000	2,653,200
New Mexico.....	2,900,000	6.50	65	18,850,000	6,597,500
Arizona.....	850,000	6.70	66	5,695,000	1,936,300
Utah.....	1,750,000	6.60	65	11,550,000	4,042,500
Nevada.....	825,000	7.00	67	5,775,000	1,905,750
Idaho.....	2,100,000	7.40	64	15,540,000	5,594,400
Washington.....	400,000	9.00	69	3,600,000	1,116,000
Oregon.....	2,150,000	8.50	69	18,270,000	5,665,250
California.....	1,700,000	7.00	67	11,900,000	3,927,000
United States:					
1912.....	38,481,000	6.82	55	304,043,400	136,866,652
1911.....	39,761,000	6.98	60.4	318,547,900	139,896,195
1910.....	41,999,500	6.70	60	321,362,750	141,805,813
1909.....	42,293,205	6.80	60.9	328,110,749	142,229,785
1908.....	40,311,548	6.70	60.5	311,138,321	135,330,648
1907.....	38,864,931	6.60	60.6	298,294,750	130,359,118
1906.....	38,540,798	6.66	61.1	298,915,130	129,410,942
1905.....	38,621,476	6.56	61.3	295,488,438	126,527,121
1904.....	38,342,072	6.50	61.6	291,783,032	123,935,147
1903.....	39,284,000	6.25	60.8	287,450,000	124,366,405
1902.....	42,184,122	6.50	60	316,346,032	137,912,085
1901.....	41,920,900	6.33	60.6	302,502,328	126,814,690
1900.....	40,267,818	6.46	61.1	288,636,621	118,223,120
1899.....	36,905,497	6.46	60.7	272,191,330	113,958,468

<sup>1</sup> Totals include pulled wool

TABLE 161.—Range of price of wool per pound in Boston, 1899–1912<sup>1</sup>.

Date.	Ohio fine, unwashed.		Indiana quarter blood, unwashed.		Ohio XX, washed.		Ohio No. 1, washed.		Ohio Delaine, washed.		Michigan fine, unwashed. <sup>2</sup>		Fine select- ed Territory, staple scoured.		Fine medi- um Territory, cloth- ing scoured.		Texas, 12 months, scoured.		Fine free fall, Texas scoured.		Pulled, A super, scoured.		Pulled, B super, scoured.	
	Low.	High.	Low.	High.	Low.	High.	Low.	High.	Low.	High.	Low.	High.	Low.	High.	Low.	High.	Low.	High.	Low.	High.	Low.	High.	Low.	High.
1899.....	Cts. 16	Cts. 26	Cts. 20	Cts. 28	Cts. 25½	Cts. 38	Cts. 28½	Cts. 39	Cts. 27	Cts. 40	Cts. 21	Cts. 30	Cts. 42	Cts. 75	Cts. 38	Cts. 62	Cts. 40	Cts. 65	Cts. 30	Cts. 52	Cts. 40	Cts. 57	Cts. 30	Cts. 52
1900.....	16	26	23	29	27	38	28	39	27½	40	21½	29	49	74	45	62	48	65	40	55	42	57	37	50
1901.....	16½	19½	19½	24	26	28	25	29	27½	30	20	22	43	50	35	44	43	50	36	42	35	45	30	38
1902.....	19	23	20½	24	27	32	26	31	28	35	21	27	48	59	42	50	48	60	38	48	38	46	33	40
1903.....	20	25	22	25	30	35	29	34	33½	37	21	27½	52	60	50	58	48	60	44	48	40	47	39	44
1904.....	21	25	24	33	32	36	30	40	34	38	19	22	50	70	50	68	52	68	44	56	43	60	40	55
1905.....	23	30	30	37	34	37	36	43	36	40	20	27	65	78	60	72	63	76	54	63	55	65	52	60
1906.....	24	28	30	34	33½	36	37	41	35½	37½	24	26½	70	78	65	70	72	76	58	63	53	69	47	56
1907.....	25	28	29	34	33	35	38	41	36	39	23	26	70	75	66	73	70	75	50	62	45	60	38	52
1908.....	19	27	20	30	30	35	31	40	31	39	18	25	53	72	43	62	50	72	42	53	42	55	32	45
1909.																								
January.....	23	24	27	28	34	35	38	39	37	40	22	23	62	65	60	62	60	65	48	50	47	55	38	48
February.....	23	24	27	29	34	35	38	39	38	40	22	23	62	65	60	62	62	65	48	50	50	55	40	48
March.....	23	24	27	29	34	35	38	39	38	40	22	23	63	65	60	62	62	65	48	50	50	55	40	48
April.....	23	24	27	29	34	35	38	39	39	40	22	23	63	65	60	62	62	65	45	47	50	56	40	48
May.....	23	28	28	37	34	35	38	40	39	42	23	25	63	77	60	72	62	67	45	55	55	60	46	53
June.....	27	28	36	37	35	36	40	41	40	42	25	26	74	78	69	72	70	72	58	60	55	62	48	53
July.....	27	28	32	37	35	36	40	41	40	42	25	26	74	78	69	72	70	75	58	60	55	62	48	53
August.....	27	28	32	33	35	36	40	41	39	40	25	26	75	80	69	72	73	78	58	60	55	62	48	55
September.....	27	28	32	33	35	37	40	41	39	41	25	26	77	80	70	72	75	78	58	60	55	63	50	58
October.....	27	28	32	33	36	37	40	41	40	41	25	26	77	80	70	72	75	78	58	60	60	64	52	58
November.....	27	28	32	33	37	38	40	41	39	41	25	26	77	80	70	72	75	78	58	60	60	64	52	58
December.....	27	28	32	33	37	38	40	41	39	40	25	26	77	80	70	72	73	78	58	62	60	65	52	58
Year.....	23	28	27	37	34	38	38	41	37	42	22	26	62	80	60	72	60	78	45	62	47	65	38	58
1910.																								
January.....	27	28	32	33	37	38	40	( <sup>3</sup> ) 41	39	40	25	26	75	80	64	68	73	75	60	( <sup>4</sup> ) 62	60	65	52	58
February.....	27	28	32	36	37	38	40	41	39	40	25	26	75	76	64	68	70	75	60	62	60	65	52	58
March.....	25	28	34	36	36	38	40	41	37	40	24	26	70	75	63	68	68	71	60	62	60	65	52	58
April.....	23	26	29	35	33	37	36	41	35	38	22	25	63	72	57	65	65	70	52	60	57	63	48	58
May.....	23	24	28	30	33	34	36	37	35	35	22	23	63	66	55	58	60	67	52	54	56	58	48	54
June.....	20	24	26	28	32	34	36	37	34	35	22	23	63	65	56	58	60	61	52	54	56	58	48	52
July.....	20	21	24	26	30	32	27	29	34	34	19	20	60	64	54	56	55	60	48	52	56	57	45	51
August.....	20	21	24	28	30	30	28	29	34	34	19	20	60	65	55	57	55	60	48	50	56	62	45	48

<sup>1</sup> From Commercial Bulletin, Boston.

<sup>2</sup> Quoted as X, washed, to June, 1903.

<sup>3</sup> From July, 1910, quotations are for Ohio half blood, unwashed, approximately 7 cents lower than Ohio No. 1.

<sup>4</sup> Excluding California.

TABLE 161.—Range of price of wool per pound in Boston, 1899-1912—Continued.

Date.	Ohio fine, unwashed.		Indiana quarter-blood unwashed.		Ohio XX, washed.		Ohio No. 1, washed.		Ohio Delaine, washed.		Michigan fine, unwashed.		Fine select Territory, staple scoured.		Fine medium Territory, clothing scoured.		Texas, 12 months, scoured.		Fine free fall, Texas scoured.		Pulled, A, super, scoured.		Pulled, B super, scoured.		
	Low.	High.	Low.	High.	Low.	High.	Low.	High.	Low.	High.	Low.	High.	Low.	High.	Low.	High.	Low.	High.	Low.	High.	Low.	High.	Low.	High.	
1910.	Cts.	Cts.	Cts.	Cts.	Cts.	Cts.	Cts.	Cts.	Cts.	Cts.	Cts.	Cts.	Cts.	Cts.	Cts.	Cts.	Cts.	Cts.	Cts.	Cts.	Cts.	Cts.	Cts.	Cts.	Cts.
September.....	20	23	27	28	30	30	28	29	34	34	19	21	64	65	55	58	57	62	50	50	56	57	45	48	48
October.....	21	23	27	28	30	30	28	30	34	34	19	21	64	65	55	56	57	60	50	50	56	57	45	48	48
November.....	22	24	27	28	30	32	29	30	34	34	19	21	64	66	55	56	58	60	48	50	50	55	45	52	52
December.....	22	24	27	28	31	32	29	30	34	35	20	21	63	65	55	56	58	60	48	50	53	55	47	47	47
Year.....	20	28	24	36	30	38	27	41	34	40	19	26	60	80	54	68	55	75	48	62	50	65	45	58	58
1911.																									
January.....	22	22	26	27	31½	32	29	30	34	34	20	21	60	62	58	59	57	60	48	50	53	55	43	47	47
February.....	22	22	26	27	31½	32	29	30	34	34	20	21	60	62	58	59	54	59	45	50	53	55	42	45	45
March.....	21	22	25	25½	31	32	27	30	33	34	20	21	57	58	55	57	48	55	43	45	47	53	42	43	43
April.....	18	20½	23	24	28	29	26	27	30	32	17	20	53	56	51	53	47	50	41	43	46	47	41	42	42
May.....	18	20	22½	23	27	29	25	27	29	30	17	17½	55	57	52	55	46	48	41	42	45	48	41	42	42
June.....	18	19½	22½	23½	27	28	25	25	30	30	17	18	55	58	53	56	46	51	41	43	45	48	41	42	42
July.....	19½	21	23	24	27	28	25	26	29	30	18	19	55	59	53	57	52	53	42	43	46	48	41	44	44
August.....	21	22	24	25	28	29	25	26	30	31	19	21	60	62	58	60	52	55	42	45	46	48	42	45	45
September.....	20	21	24	24½	28	28	25	26½	30	30	19	20	60	62	58	59	53	55	43	45	46	48	42	45	45
October.....	21	21	23½	24	28	28	25	26	30	31	19	20	57	60	56	57	51	55	42	45	45	46	42	44	44
November.....	21	21	23	24	28	28	25½	26	30	31	19	20	58	60	56	59	51	53	42	44	45	46	42	44	44
December.....	21	21	24	25	28	28	26	26	31	32	19	20	60	62	58	60	52	53	42	43	45	46	42	42	42
Year.....	18	22	22½	27	27	32	25	30	29	34	17	21	53	62	51	60	46	60	41	50	5	55	41	47	47
1912.																									
January.....	21	21½	22½	24	28	29	26	28	31	32	20	20½	60	62	48	50	52	52	42	44	45	49	41	47	47
February.....	21½	21½	27	29	28	29	29	30	32	32	20	20½	62	63	50	53	53	54	43	43	48	54	47	54	54
March.....	21	21½	27	28	28	29	26½	30	31	32	19	20½	62	63	50	53	53	54	43	43	51	53	47	54	54
April.....	21	21	27	28	28	28	26	27	30	31	19	20	62	63	50	52	53	53	43	44	51	53	47	49	49
May.....	21	21	25	26	28	28	26	26	30	30	19	20	61	63	50	52	53	53	43	45	51	53	47	49	49
June.....	21	23	26	27	28	30	26	30	30	35	19	22	62	65	50	55	53	56	43	45	52	53	49	51	51
July.....	22	24	27½	31	30	32	29	30	33	35	21	22	63	65	53	57	54	62	43	46	52	53	49	51	51
August.....	23	25	28½	29	31	33	29	30	34	35	21	23	64	67	56	59	60	62	45	47	52	57	49	54	54
September.....	23	25	32	33	31	32	29	31	34	35	22½	23	66	67	58	59	60	62	46	47	55	58	50	54	54
October.....	23	24	32	33	31	32	29	30	34	35	22½	23	66	67	57	59	60	62	46	47	56	58	52	54	54
November.....	24	24	32	33	32	32	29	30	34	34	22	23	66	67	57	59	60	65	46	48	56	58	52	53	53
December.....	24	24	32	33	32	32	28½	30	34	34	22	23	64	67	57	59	62	63	47	48	55	57	48	53	53
Year.....	21	25	22½	33	28	33	26	30	30	35	19	23	60	67	48	59	52	65	42	48	45	58	41	54	54

TABLE 162.—Wholesale price of wool per pound, 1899–1912.

Date.	Boston.		Philadelphia.		St. Louis.	
	Ohio XX, washed.		Ohio XX, washed.		Best tub washed.	
	Low.	High.	Low.	High.	Low.	High.
	<i>Cents.</i>	<i>Cents.</i>	<i>Cents.</i>	<i>Cents.</i>	<i>Cents.</i>	<i>Cents.</i>
1899.....	25½	38	25½	36	25½	35
1900.....	27	38	27	37	28	36
1901.....	26	28	25	28	24	29½
1902.....	27	32	26	32	24	29
1903.....	30	35	30	34	27	31
1904.....	32	36	31½	33½	30½	41
1905.....	34	37	34	36	37	43
1906.....	33½	36	33	35	31	40
1907.....	33	35	33	34	33	38
1908.....	30	35	30	34	22	33
1909.						
January.....	34	35	32	33	30	31
February.....	34	35	32	33	31	32
March.....	34	35	32	33	31	32
April.....	34	35	33	34	31	32
May.....	34	35	34	35	32	38
June.....	35	36	34	35	36	38
July.....	35	36	34	35	36	36½
August.....	35	36	34	35	36	37½
September.....	35	37	34	35	37	37½
October.....	36	37	34	35	37	38
November.....	37	38	34	35	38	38
December.....	37	38	34	35	37	38
Year.....	34	38	32	35	30	38
1910.						
January.....	37	38	34	35	37	37
February.....	37	38	34	35	37	37
March.....	36	38	34	35	36	37
April.....	33	37	33	35	36	36
May.....	33	34	32	34	33	36
June.....	32	34	31	33	31	33
July.....	30	32	30	32	32	33
August.....	30	30	30	31	33	33
September.....	30	30	30	31	33	33
October.....	30	30	30	31	33	33
November.....	30	32	30	31	33	33
December.....	31	32	30	31	33	33
Year.....	30	38	30	35	31	37
1911.						
January.....	31½	32	30	31	33	33
February.....	31½	32	30	31	33	33
March.....	31	32	30	31	31	33
April.....	28	29	29	30	28	30
May.....	27	29	27½	29	28	31
June.....	27	28	27½	28	30	31
July.....	27	28	27½	28	30	30
August.....	28	29	27½	28	30	30
September.....	28	28	27	28	31	31
October.....	28	28	27	28	30	31
November.....	28	28	27	28	30	30
December.....	28	28	27	28	30	30
Year.....	27	32	27	31	28	33
1912.						
January.....	28	29	25 <sup>(1)</sup>	27	27	30
February.....	28	29	28	30	27	30
March.....	28	29	28	30	27	35
April.....	28	28	28	30	30	33
May.....	28	28	27	29	31	35
June.....	28	30	27	30	31	35
July.....	30	32	28	31	35	35
August.....	31	33	29	31	35	36
September.....	31	32	29	31	36	36
October.....	31	32	29	31	36	36
November.....	32	32	30	31	36	38
December.....	32	32	30	31	37	38
Year.....	28	33	25	31	27	38

<sup>1</sup> One-fourth to three-eighths unwashed.

TABLE 163.—*International trade in wool, calendar years, 1907–1911.*

Under wool have been included washed, unwashed, scoured, and pulled wool; slipes, sheep's wool on skins (total weight of wool and skins taken), and all other animal fibers included in United States classification of wool. The following items have been considered as not within this classification: Carded, combed, and dyed wool; flocks, goatskins with hair on, mill waste, noils, and tops. See "General note," p. 564.]

EXPORTS.

Country.	1907	1908	1909	1910	1911
	<i>Pounds.</i>	<i>Pounds.</i>	<i>Pounds.</i>	<i>Pounds.</i>	<i>Pounds.</i>
Algeria.....	26,623,852	16,233,352	127,224,960	121,931,361	115,314,254
Argentina.....	341,294,126	386,991,394	339,512,862	332,010,450	291,086,566
Australia.....	637,836,589	598,032,199	641,157,751	733,796,070	710,674,149
Belgium.....	40,778,030	40,464,681	40,651,742	241,457,748	235,209,810
British India.....	44,194,774	32,108,670	63,052,315	54,458,894	62,143,913
British South Africa.....	116,472,023	122,443,922	150,630,571	139,488,573	153,289,110
Chile.....	27,453,101	28,074,324	29,340,964	32,086,778	23,904,822
China.....	39,429,333	33,441,467	50,057,733	31,091,867	47,275,467
France.....	84,638,644	72,336,453	91,793,812	82,637,226	181,886,560
Germany.....	32,043,641	31,506,388	41,180,605	39,807,139	35,581,362
Netherlands.....	20,296,264	26,359,181	27,520,247	20,836,188	21,432,125
New Zealand.....	177,535,594	168,035,607	198,021,725	211,633,426	175,981,629
Persia <sup>2</sup> .....	10,424,109	13,490,246	10,323,935	10,323,935	10,323,935
Peru.....	8,406,177	6,743,230	8,375,328	19,426,027	10,426,027
Russia.....	30,351,617	14,486,072	29,629,433	21,816,302	30,871,677
Spain.....	32,203,478	14,372,925	36,906,860	23,935,503	24,757,321
Turkey <sup>3</sup> .....	40,156,183	40,156,183	40,156,183	40,156,183	40,156,183
United Kingdom.....	31,148,692	38,311,090	62,941,681	38,185,983	31,373,218
Uruguay <sup>4</sup> .....	99,839,339	116,127,305	128,708,080	103,595,404	103,595,404
Other countries.....	42,762,000	32,216,000	48,585,000	44,036,000	42,046,000
Total.....	1,883,887,566	1,831,930,759	2,115,771,787	2,233,211,057	2,147,329,532

IMPORTS.

Austria-Hungary.....	52,919,439	60,634,216	67,222,884	61,262,968	65,148,135
Belgium.....	148,251,861	131,117,062	131,380,685	355,584,811	340,039,704
British India.....	20,626,006	18,470,491	20,252,059	20,702,336	22,468,689
Canada.....	6,406,325	4,468,680	8,235,570	6,435,074	6,876,934
France.....	554,976,617	504,905,457	622,749,015	608,248,038	1603,730,592
Germany.....	439,912,939	430,572,269	471,480,165	471,055,339	468,711,629
Japan.....	18,916,700	4,228,771	7,754,818	9,843,913	8,323,399
Netherlands.....	24,081,688	31,713,802	28,612,749	25,867,813	29,376,343
Russia.....	78,494,890	71,353,043	94,975,797	110,496,465	104,326,654
Sweden.....	11,622,219	12,050,703	12,856,083	4,964,027	5,791,041
Switzerland.....	10,323,701	11,097,515	11,524,546	11,154,394	11,634,556
United Kingdom.....	527,766,993	470,804,920	500,198,977	548,445,334	568,230,493
United States.....	188,305,955	142,559,384	312,131,171	180,134,981	155,922,510
Other countries.....	44,401,000	48,431,000	54,445,000	49,982,000	153,914,000
Total.....	2,127,006,333	1,942,407,313	2,343,819,519	2,464,177,493	2,444,493,684

<sup>1</sup> Preliminary.

<sup>2</sup> Year beginning Mar. 21.

<sup>3</sup> Data for 1909.

<sup>4</sup> Year preceding.

<sup>5</sup> Data for year beginning Mar. 14, 1905.

<sup>6</sup> Year beginning July 1.



## SWINE.

TABLE 164.—Number and value of swine on farms in the United States, 1867–1913.

Jan. 1—	Number.	Price per head.	Farm value.	Jan. 1—	Number.	Price per head.	Farm value.
1867.....	24,694,000	\$4.03	\$99,637,000	1891.....	50,625,000	\$4.15	\$210,194,000
1868.....	24,317,000	3.29	79,976,000	1892.....	52,398,000	4.60	241,031,000
1869.....	23,316,000	4.65	108,431,000	1893.....	46,095,000	6.41	295,426,000
1870.....	26,751,000	5.80	155,108,000	1894.....	45,206,000	5.98	270,385,000
1871.....	29,458,000	5.61	165,312,000	1895.....	44,166,000	4.97	219,501,000
1872.....	31,796,000	4.01	127,453,000	1896.....	42,843,000	4.35	186,530,000
1873.....	32,632,000	3.67	119,632,000	1897.....	40,600,000	4.10	166,273,000
1874.....	30,861,000	3.98	122,695,000	1898.....	39,760,000	4.39	174,351,000
1875.....	28,062,000	4.80	134,581,000	1899.....	38,652,000	4.40	170,110,000
1876.....	25,727,000	6.00	154,251,000	1900.....	37,079,000	5.00	185,472,000
1877.....	28,077,000	5.66	158,873,000	1901 <sup>1</sup> .....	56,982,000	6.20	353,012,000
1878.....	32,262,000	4.85	156,577,000	1902.....	48,699,000	7.03	342,121,000
1879.....	34,766,000	3.18	110,508,000	1903.....	46,923,000	7.78	364,974,000
1880.....	34,034,000	4.28	145,782,000	1904.....	47,009,000	6.15	289,225,000
1881.....	36,248,000	4.70	170,535,000	1905.....	47,321,000	5.99	283,255,000
1882.....	44,122,000	5.97	263,543,000	1906.....	52,103,000	6.18	321,803,000
1883.....	43,270,000	6.75	291,951,000	1907.....	54,794,000	7.62	417,791,000
1884.....	44,201,000	5.57	246,301,000	1908.....	56,084,000	6.05	339,030,000
1885.....	45,143,000	5.02	226,402,000	1909.....	54,147,000	6.55	354,794,000
1886.....	46,092,000	4.26	196,570,000	1910.....	47,782,000	9.14	436,603,000
1887.....	44,613,000	4.48	200,043,000	1911 <sup>1</sup> .....	65,620,000	9.37	615,170,000
1888.....	44,347,000	4.98	220,811,000	1912.....	65,410,000	8.00	523,328,000
1889.....	50,302,000	5.79	291,307,000	1913.....	61,178,000	9.86	603,109,000
1890.....	51,603,000	4.72	243,418,000				

<sup>1</sup> Estimates of number revised, based on census data; see Table 140, p. 677.

TABLE 165.—Number and value of swine on farms, by States, Jan. 1, 1912 and 1913.

State and division.	Number Jan. 1. <sup>1</sup>		Average price per head Jan. 1.		Farm value Jan. 1. <sup>1</sup>	
	1913	1912	1913	1912	1913	1912
Maine.....	101	101	\$12.90	\$11.50	\$1,303	\$1,162
New Hampshire.....	52	53	12.70	10.50	660	556
Vermont.....	107	111	12.20	10.00	1,305	1,110
Massachusetts.....	115	117	13.00	11.30	1,495	1,322
Rhode Island.....	14	16	14.50	12.00	203	192
Connecticut.....	58	60	14.00	11.60	812	696
New York.....	761	777	12.60	10.20	9,589	7,925
New Jersey.....	160	165	13.00	11.30	2,080	1,864
Pennsylvania.....	1,130	1,141	12.50	10.00	14,125	11,410
North Atlantic.....	2,498	2,541	12.64	10.32	31,572	26,237
Delaware.....	58	59	11.20	7.20	650	425
Maryland.....	335	345	9.80	8.00	3,283	2,760
Virginia.....	836	880	7.00	6.30	5,852	5,544
West Virginia.....	356	363	9.00	6.70	3,204	2,432
North Carolina.....	1,335	1,405	7.70	7.40	10,280	10,397
South Carolina.....	765	797	8.50	8.00	6,502	6,376
Georgia.....	1,888	2,098	7.10	6.70	13,405	14,057
Florida.....	878	954	5.90	5.20	5,180	4,961
South Atlantic.....	6,451	6,901	7.50	6.80	48,356	46,952
Ohio.....	3,399	3,578	10.80	8.20	36,709	29,340
Indiana.....	3,709	4,031	9.80	7.70	36,348	31,039
Illinois.....	4,315	4,640	10.50	8.80	45,308	40,832
Michigan.....	1,313	1,382	10.80	8.50	14,180	11,747
Wisconsin.....	2,030	2,051	11.60	9.60	23,548	19,690
North Central East of Mississippi River.....	14,766	15,682	10.57	8.52	156,093	132,648

<sup>1</sup> Expressed in thousands; 000 omitted.

TABLE 165.—Number and value of swine on farms, by States, Jan. 1, 1912 and 1913—Continued.

State and division.	Number Jan. 1. <sup>1</sup>		Average price per head Jan. 1.		Farm value Jan. 1. <sup>1</sup>	
	1913	1912	1913	1912	1913	1912
Minnesota.....	1,702	1,702	\$12.70	\$10.40	\$21,615	\$17,701
Iowa.....	8,720	9,689	12.00	9.80	104,640	94,952
Missouri.....	4,087	4,491	8.50	7.00	34,740	31,437
North Dakota.....	366	359	13.70	10.50	5,014	3,770
South Dakota.....	1,181	1,104	11.00	8.90	12,991	9,826
Nebraska.....	3,798	4,267	11.40	8.80	43,297	37,550
Kansas.....	2,611	2,808	10.40	7.90	27,154	22,183
North Central West of Mississippi River.....	22,465	24,420	11.10	8.90	249,451	217,419
Kentucky.....	1,638	1,724	7.10	5.40	11,630	9,310
Tennessee.....	1,495	1,574	7.40	6.10	11,063	9,601
Alabama.....	1,456	1,533	6.80	6.50	9,901	9,964
Mississippi.....	1,482	1,577	6.90	6.50	10,226	10,250
Louisiana.....	1,412	1,642	7.00	5.80	9,884	9,524
Texas.....	2,493	2,544	8.40	6.30	20,941	16,027
Oklahoma.....	1,325	1,410	8.90	5.50	11,792	7,755
Arkansas.....	1,529	1,738	6.70	5.40	10,244	9,385
South Central.....	12,830	13,742	7.46	5.95	95,681	81,816
Montana.....	153	143	11.90	9.90	1,821	1,416
Wyoming.....	41	43	11.00	8.60	451	370
Colorado.....	205	211	11.00	8.00	2,255	1,688
New Mexico.....	52	50	9.60	8.20	499	410
Arizona.....	23	22	11.50	10.50	264	231
Utah.....	81	79	11.00	9.00	891	711
Nevada.....	32	30	11.00	10.50	352	315
Idaho.....	233	212	10.30	8.00	2,400	1,696
Washington.....	258	246	11.30	9.50	2,915	2,337
Oregon.....	268	258	9.50	8.50	2,546	2,193
California.....	822	830	9.20	8.30	7,562	6,889
Far Western.....	2,168	2,124	10.13	8.60	21,956	18,256
United States.....	61,178	65,410	9.86	8.00	603,109	523,328

<sup>1</sup> Expressed in thousands; 000 omitted.

TABLE 166.—Wholesale price of live hogs per 100 pounds, 1899–1912.

Date.	Cincinnati.		St. Louis.		Chicago.		Kansas City.	
	Packing, fair to good.		Mixed packers.					
	Low.	High.	Low.	High.	Low.	High.	Low.	High.
1899.....	\$3.45	\$4.85	\$3.40	\$4.85	\$3.30	\$5.00	\$3.62½	\$4.80
1900.....	4.45	5.85	4.40	5.75	3.35	5.85	4.40	5.67½
1901.....	5.15	7.20	4.90	7.10	3.00	7.40	5.05	7.12½
1902.....	5.85	8.00	5.80	8.20	4.40	8.20	6.10	8.17½
1903.....	4.15	7.75	4.20	7.60	3.75	7.85	4.35	7.60
1904.....	4.35	6.25	4.25	6.30	3.60	6.37½	4.47½	6.07½
1905.....	4.60	6.35	4.75	6.35	3.90	6.45	4.55	6.25
1906.....	5.30	6.95	5.10	6.97	4.60	7.00	5.20	6.87½
1907.....	4.15	7.40	4.00	7.22	3.10	7.25	4.00	7.15
1908.....	4.15	7.35	4.20	7.35	3.95	7.60	4.00	7.15

TABLE 166.—Wholesale price of live hogs per 100 pounds, 1899–1912—Continued.

Date.	Cincinnati.		St. Louis.		Chicago.		Kansas City.	
	Packing, fair to good.		Mixed packers.					
	Low.	High.	Low.	High.	Low.	High.	Low.	High.
1909.								
January.....	\$5.75	\$6.75	\$5.75	\$6.60	\$5.20 <sup>(1)</sup>	\$6.70	\$5.25	\$6.40
February.....	6.15	7.10	6.05	6.75	5.75	6.95	5.70	6.50
March.....	6.30	7.30	6.10	7.05	5.95	7.15	6.00	6.90
April.....	6.80	7.55	6.75	7.45	6.50	7.60	6.60	7.30
May.....	7.05	7.55	6.95	7.40	6.75	7.55	6.60	7.45
June.....	7.05	8.15	7.10	8.00	6.80	8.20	6.85	7.90
July.....	7.40	8.40	7.60	8.20	7.00	8.45	7.20	8.05
August.....	7.75	8.30	7.60	8.10	6.95	8.25	7.40	8.00
September.....	7.60	8.45	7.70	8.40	7.20	8.60	7.65	8.30
October.....	7.25	8.15	7.25	8.05	6.85	8.40	7.00	8.10
November.....	7.55	8.25	7.70	8.40	7.20	8.45	7.40	8.20
December.....	7.95	8.80	7.80	8.65	7.65	8.75	7.90	8.50
Year.....	5.75	8.80	5.75	8.65	5.20	8.75	5.25	8.50
1910.								
January.....	8.00	9.00	7.70	8.85	7.75	9.05	7.90	8.65
February.....	8.25	9.85	8.00	9.65	8.05	10.00	8.15	9.55
March.....	9.75	11.10	9.50	10.95	9.45	11.20	9.35	10.90
April.....	9.00	11.05	8.85	11.05	8.75	11.00	8.70	10.75
May.....	9.25	9.90	9.15	9.75	9.05	9.80	8.95	9.60
June.....	9.10	9.70	9.22	9.67	9.10	9.80	9.05	9.60
July.....	8.45	9.40	8.40	9.60	8.30	9.60	8.00	9.30
August.....	8.35	9.60	8.00	9.35	8.20	9.70	7.65	9.55
September.....	8.85	10.15	8.60	9.95	8.65	10.10	8.50	9.80
October.....	8.65	9.35	8.25	9.37	8.25	9.65	8.00	9.35
November.....	6.95	8.60	6.80	8.80	6.50	8.70	6.90	8.55
December.....	7.25	8.20	7.00	8.05	6.80	8.10	7.20	7.85
Year.....	6.95	11.10	6.80	11.05	6.50	11.20	6.90	10.90
1911.								
January.....	7.85	8.25	7.55	8.22	7.30	8.30	7.55	8.05
February.....	7.25	7.90	7.00	7.97	6.60	7.90	6.80	7.70
March.....	6.75	7.50	6.50	7.25	6.10	7.35	6.35	7.10
April.....	6.15	6.90	5.85	7.15	5.65	6.90	5.85	6.65
May.....	5.85	6.50	5.80	6.35	5.35	6.50	5.72	6.15
June.....	5.90	6.65	5.85	6.65	5.55	6.72½	5.80	6.45
July.....	6.65	7.35	6.35	7.25	6.10	7.50	6.15	7.05
August.....	7.35	8.00	7.10	7.75	6.45	7.95	6.85	7.60
September.....	6.50	7.65	6.55	7.65	5.75	7.80	6.25	7.40
October.....	6.10	6.95	6.00	6.50	5.65	6.90	5.65	6.55
November.....	5.75	6.55	6.00	6.45	5.30	6.72½	5.60	5.60
December.....	5.90	6.45	5.90	6.45	5.40	6.60	5.60	6.35
Year.....	5.75	8.25	5.80	8.22	5.30	8.30	5.60	8.05
1912.								
January.....	6.10	6.50	5.75	6.25	5.55 <sup>(1)</sup>	6.65	5.65	6.45
February.....	6.15	6.70	6.10	6.35	5.60	6.57½	5.75	6.40
March.....	6.55	8.00	6.30	7.95	6.15	7.95	6.15	7.90
April.....	7.75	8.25	7.60	8.05	7.30	8.17½	7.35	8.05
May.....	7.35	8.10	7.55	8.00	6.90	8.05	7.15	7.95
June.....	7.00	7.80	7.20	7.70	6.90	7.80	7.15	7.80
July.....	7.50	8.45	7.25	8.35	6.90	8.50	7.20	8.20
August.....	8.30	9.00	8.10	9.00	7.10	9.00	8.00	8.82½
September.....	8.45	9.35	8.45	9.15	7.60	9.27½	8.25	8.90
October.....	7.60	9.25	8.40	9.25	7.00	9.40	7.35	9.05
November.....	7.25	8.10	7.50	8.20	7.20	8.32½	7.40	8.00
December.....	7.10	7.80	7.15	7.65	6.80	7.85	6.90	7.90
Year.....	6.10	9.35	5.75	9.25	5.55	9.40	5.65	9.05

<sup>1</sup> Light to heavy.

TRANSPORTATION.

TABLE 167.—Tonnage carried on railways in the United States, 1907–1911.<sup>1</sup>

[Tons of 2,000 pounds.]

Product.	Year ending June 30—				
	1907	1908	1909	1910	1911 <sup>2</sup>
<b>FARM PRODUCTS.</b>					
<b>Animal matter:</b>	<i>Tons.</i>	<i>Tons.</i>	<i>Tons.</i>	<i>Tons.</i>	<i>Tons.</i>
Animals, live.....	11,727,889	11,541,195	11,699,070	11,502,305	13,991,205
<b>Packing-house products—</b>					
Dressed meats.....	1,952,538	2,081,155	2,131,803	2,274,220	2,329,814
Hides (including leather)....	1,082,585	937,872	1,155,884	1,214,849	1,096,193
Other packing-house products.....	2,312,313	2,054,744	1,982,194	1,760,583	2,249,082
<b>Total packing-house products.....</b>	<b>5,347,436</b>	<b>5,073,771</b>	<b>5,269,881</b>	<b>5,249,652</b>	<b>5,675,089</b>
<b>Poultry (including game and fish).....</b>	<b>838,905</b>	<b>717,201</b>	<b>713,012</b>	<b>698,356</b>	<b>718,902</b>
Wool.....	329,786	317,391	403,904	366,995	375,475
Other animal matter.....	2,229,470	1,985,592	2,507,485	2,476,836	3,002,591
<b>Total animal matter.....</b>	<b>20,473,486</b>	<b>19,635,150</b>	<b>20,593,352</b>	<b>20,294,144</b>	<b>23,763,262</b>
<b>Vegetable matter:</b>					
Cotton.....	4,332,664	3,419,173	3,950,479	3,023,757	3,486,124
Fruit and vegetables.....	9,719,117	9,516,962	9,762,769	11,339,921	11,747,009
<b>Grain and grain products—</b>					
Grain.....	36,715,384	33,058,061	34,111,231	37,420,965	41,058,154
<b>Grain products—</b>					
Flour.....	7,880,527	6,871,886	7,744,810	8,038,694	8,633,731
Other grain products.....	5,698,119	5,153,412	5,210,092	6,005,219	6,489,806
<b>Total grain and grain products.....</b>	<b>50,294,030</b>	<b>45,083,359</b>	<b>47,066,133</b>	<b>51,464,868</b>	<b>56,181,741</b>
Hay.....	5,847,828	5,446,336	5,453,515	5,975,949	6,306,745
Sugar.....	2,610,287	2,589,091	2,499,122	2,848,145	2,882,880
Tobacco.....	928,151	802,597	794,433	943,071	934,174
Other vegetable matter.....	5,908,281	5,397,516	6,656,391	5,989,021	6,910,260
<b>Total vegetable matter.....</b>	<b>79,640,358</b>	<b>72,255,034</b>	<b>76,182,842</b>	<b>81,584,732</b>	<b>88,448,933</b>
<b>Total farm products.....</b>	<b>100,113,844</b>	<b>91,890,184</b>	<b>96,776,194</b>	<b>101,878,876</b>	<b>112,212,195</b>
<b>OTHER FREIGHT.</b>					
Products of mines.....	476,899,638	444,216,023	459,560,732	544,604,373	539,255,980
Products of forests.....	101,617,724	90,475,081	97,104,700	113,010,825	108,506,272
Manufactures (except sugar)....	135,011,156	102,271,178	106,178,007	136,830,246	132,292,656
All other (including freight in less than carload lots).....	79,542,610	68,363,633	66,873,132	72,139,689	74,966,888
<b>Grand total.....</b>	<b>893,184,972</b>	<b>797,216,099</b>	<b>826,492,765</b>	<b>968,464,009</b>	<b>967,233,991</b>

<sup>1</sup> Compiled from reports of the Interstate Commerce Commission. Original shipments only, excluding freight received by each railway from connecting railways and other carriers.

<sup>2</sup> Preliminary.

TABLE 168.—Average revenue of railroads for freight traffic, per short ton per mile, 1890-1911.

[Based upon reports of the Interstate Commerce Commission.]

Year ending June 30—	District. <sup>1</sup>			United States.	Year ending June 30—	District. <sup>1</sup>			United States.
	East-ern.	South-ern.	West-ern.			East-ern.	South-ern.	West-ern.	
1890.....	0.802	1.008	1.141	0.941	1904.....	0.696	0.808	0.909	0.780
1891.....	.776	.992	1.093	.895	1905.....	.680	.787	.909	.766
1892.....	.761	.916	1.143	.898	1906.....	.665	.772	.882	.748
1893.....	.761	.881	1.083	.878	1907.....	.667	.787	.902	.759
1894.....	.750	.867	1.059	.860	1908.....	.651	.780	.892	.754
1895.....	.725	.822	1.106	.839	1909.....	.652	.767	.912	.763
1896.....	.701	.806	1.043	.806	1910.....	.646	.746	.902	.753
1897.....	.697	.787	1.001	.798	1911.....	.646	.709	.960	.757
1898.....	.643	.744	.965	.753	Mean:				
1899.....	.601	.729	.959	.724	1891-1895....	.755	.896	1.097	.874
1900.....	.625	.732	.920	.729	1896-1900....	.653	.760	.978	.762
1901.....	.651	.751	.919	.750	1901-1905....	.674	.780	.907	.763
1902.....	.665	.760	.906	.757	1906-1910....	.656	.770	.898	.755
1903.....	.678	.796	.891	.763					

<sup>1</sup> Statistics given by "districts" for the first time officially in 1911; data for earlier years computed approximately from returns for the 10 territorial "groups" (see Table 182, note 2). The Eastern district comprises that portion of the United States "bounded on the west by the northern and western shore of Lake Michigan to Chicago, thence by a line to Peoria, thence to East St. Louis, thence down the Mississippi River to the mouth of the Ohio River, and on the south by the Ohio River from its mouth to Parkersburg, W. Va.; thence by a line to the southwestern corner of Maryland, thence by the Potomac River to its mouth." The Southern district is bounded on the north by the Eastern district and on the west by the Mississippi River. The remainder of the United States, exclusive of Alaska and island possessions, is included in the Western district.

TABLE 169.—Average freight revenue per ton-mile and average length of haul on railroads in the United States, for selected farm products, 1908-1911.

[Interstate Commerce Commission. Based upon returns for about one-half of the mileage operated in the United States.]

Year ending June 30—	Average freight revenue per short ton per mile.					Average length of haul.				
	Grain.	Hay.	Cotton.	Live stock.	Dressed meats.	Grain.	Hay.	Cotton.	Live stock.	Dressed meats.
	Cent.	Cent.	Cent.	Cent.	Cent.	Miles.	Miles.	Miles.	Miles.	Miles.
1908.....	0.595	0.957	1.743	1.182	0.889	231	178	217	224	327
1909.....	.611	1.025	1.781	1.166	.905	223	161	212	234	309
1910.....	.630	1.019	1.823	1.217	.904	221	163	203	228	301
1911.....	.626	1.014	1.716	1.214	.960	227	162	197	224	307

TABLE 170.—Corn and wheat: Mean proportional export freight rates per 100 pounds from Kansas City and Omaha, by rail, to leading Gulf and Atlantic ports, 1905-1912.<sup>1</sup>

Year.	To New Orleans or Galveston from—				From Kansas City or Omaha to—					
	Kansas City.		Omaha.		Boston or New York.		Philadelphia.		Baltimore.	
	Corn.	Wheat.	Corn.	Wheat.	Corn.	Wheat.	Corn.	Wheat.	Corn.	Wheat.
1905.....	14.8	16.1	15.8	17.4	22.2	25.0	21.2	24.0	20.7	23.5
1906.....	16.5	17.1	17.5	18.1	23.4	21.5	22.4	20.5	21.9	20.0
1907.....	16.9	17.9	17.9	18.9	23.4	24.4	22.4	23.4	21.9	22.9
1908.....	17.5	18.5	18.5	19.5	24.0	25.0	23.0	24.0	22.5	23.5
1909.....	17.5	18.5	18.5	19.5	24.0	25.0	23.0	24.0	22.5	23.5
1910.....	17.5	18.5	18.5	19.5	24.0	25.0	23.0	24.0	22.5	23.5
1911.....	17.5	18.5	18.5	19.5	24.0	25.0	23.0	24.0	22.5	23.5
1912.....	17.5	18.5	18.5	19.5	24.0	25.0	23.0	24.0	22.5	23.5

<sup>1</sup> Data furnished by the Interstate Commerce Commission.<sup>2</sup> For July 25 to Dec. 31, 1905, inclusive.<sup>3</sup> For second half of 1905 only.<sup>4</sup> Average based upon rates in force for two periods, amounting together to about 30 days.

TABLE 171.—Wheat: Mean annual freight rates per bushel by lake from Chicago to ports west and east of Niagara River, 1871–1912.<sup>1</sup>

[All rates are gold.]

Year.	West of Niagara River.		East of Niagara River.		Year.	West of Niagara River.		East of Niagara River.	
	Buffalo. <sup>2</sup>	Depot Harbor.	Ogdensburg.	Montreal.		Buffalo. <sup>2</sup>	Depot Harbor.	Ogdensburg.	Montreal.
Mean:	Cents.	Cents.	Cents.	Cents.		Cents.	Cents.	Cents.	Cents.
1871–1875 . . . . .	6.4	.....	.....	.....	1906 . . . . .	1.7	1.7	4.0	6.7
1876–1880 . . . . .	4.0	.....	.....	.....	1907 . . . . .	1.6	1.6	4.2	5.6
1881–1885 . . . . .	2.8	.....	.....	9 6.8	1908 . . . . .	1.1	1.2	4.1	5.5
1886–1890 . . . . .	3.1	.....	.....	4 7.5	1909 . . . . .	1.4	1.4	3.7	4.0
1891–1895 . . . . .	2.0	.....	5 3.4	8 5.6	1910 . . . . .	1.1	.....	4.0	3.1
1896–1900 . . . . .	1.9	.....	7 3.4	8 5.2	1911 . . . . .	1.1	1.0	3.2	3.9
1901–1905 . . . . .	1.6	1.6	9 3.7	10 4.9	1912 . . . . .	1.4	1.4	3.6	5.1
1906–1910 . . . . .	1.4	1.5	4.0	5.0					

<sup>1</sup> Compiled from weekly quotations in annual reports of the Chicago Board of Trade.  
<sup>2</sup> Mean rates to Buffalo from Chicago by sail vessels were: 1871–1875, 6.4 cents; 1876–1880, 4.1; 1881–1885, 3; and by steam vessels: 1871–1875, 6.3 cents; 1876–1880, 4; 1881–1885, 2.7 cents per bushel. For later years, mean rates by sail, when given, were practically the same as by steam vessels.  
<sup>3</sup> Average, 1883–1885. <sup>7</sup> Average, 1893–1900.  
<sup>4</sup> Average, 1886–1889. <sup>8</sup> Average, 1896–1898.  
<sup>5</sup> Average, 1891, 1893–1895. <sup>9</sup> Average, 1901–1903, 1905.  
<sup>6</sup> Average, 1891, 1892, 1894, 1895. <sup>10</sup> 1903 only.

TABLE 172.—Wheat: Lowest and highest freight rates per bushel by lake to Buffalo from Toledo, Duluth, and Chicago, 1882–1912.<sup>1</sup>

Year.	To Buffalo from—						Year.	To Buffalo from—					
	Toledo.		Duluth.		Chicago.			Toledo.		Duluth.		Chicago.	
	Low.	High.	Low.	High.	Low.	High.		Low.	High.	Low.	High.	Low.	High.
	Cts.	Cts.	Cts.	Cts.	Cts.	Cts.	Cts.	Cts.	Cts.	Cts.	Cts.	Cts.	Cts.
1882 . . . . .					1.50	3.50	1896 . . . . .	1.25	1.75	1.25	3.00	1.25	2.62
1883 . . . . .					2.20	5.25	1897 . . . . .	1.00	1.25	1.00	2.50	1.00	2.62
1884 . . . . .					1.60	3.00	1898 . . . . .	1.00	1.50	1.00	3.50	1.25	3.25
1885 . . . . .			1.50	5.00	1.10	3.75	1899 . . . . .	1.50	2.00	2.50	6.00	1.88	3.75
							1900 . . . . .	1.25	2.00	1.50	3.75	1.25	3.00
1886 . . . . .	1.75	3.00	3.25	8.00	2.00	5.88	1901 . . . . .	1.25	1.50	1.12	3.75	1.25	2.50
1887 . . . . .	2.25	3.00	5.00	8.00	3.00	6.00	1902 . . . . .	1.12	2.00	1.00	2.25	1.38	2.12
1888 . . . . .	1.50	2.12	2.00	5.00	1.70	4.00	1903 . . . . .	1.12	1.50	1.12	2.75	1.25	2.25
1889 . . . . .	1.75	2.00	2.00	5.00	2.00	3.60	1904 . . . . .	1.00	1.75	1.00	5.00	1.00	3.00
1890 . . . . .	1.50	2.00	2.00	5.00	1.50	2.50	1905 . . . . .	1.12	2.50	1.25	4.00	1.12	3.00
1891 . . . . .	1.00	3.00	1.25	9.50	1.00	5.25	1906 . . . . .	1.38	1.50	1.75	3.00	1.38	2.12
1892 . . . . .	1.50	2.50	2.25	4.00	1.00	3.00	1907 . . . . .	1.00	1.50	1.00	2.50	1.12	2.00
1893 . . . . .	1.00	2.00	1.25	3.50	1.00	2.75	1908 . . . . .	1.00	1.50	1.00	3.50	1.75	1.50
1894 . . . . .	1.00	2.00	1.25	3.00	.88	3.00	1909 . . . . .	1.00	1.50	1.00	2.75	1.10	2.00
1895 . . . . .	1.00	2.25	2.00	6.00	1.00	3.00	1910 . . . . .	1.25	1.25	1.00	2.00	1.00	1.75
							1911 . . . . .	1.00	1.25	.88	3.00	.75	1.50
							1912 . . . . .	1.00	1.50	1.12	4.00	1.00	2.50

<sup>1</sup> Compiled from annual reports of the Buffalo Merchants' Exchange and Buffalo Chamber of Commerce, for 1882–1909, except figures for Toledo, 1905–1909, which were supplied by the secretary of the Toledo Produce Exchange. Data for later years for Toledo supplied by the Toledo Produce Exchange, for Duluth by the Duluth Board of Trade, and for Chicago by the Chicago Board of Trade.

TABLE 173.—*Corn and wheat: Mean freight rates per bushel from Chicago to New York, 1876-1912.*<sup>1</sup>

[All rates are gold.]

Year.	Corn.			Wheat.		
	By lake and canal. <sup>2</sup>	By lake and rail.	By all rail.	By lake and canal. <sup>2</sup>	By lake and rail.	By all rail.
<b>Mean:</b>	<i>Cents.</i>	<i>Cents.</i>	<i>Cents.</i>	<i>Cents.</i>	<i>Cents.</i>	<i>Cents.</i>
1876-1880.....	9.93	12.04	16.12	10.85	13.17	17.96
1881-1885.....	7.07	9.44	13.33	7.69	10.41	14.29
1886-1890.....	7.18	9.63	13.24	7.87	10.53	14.91
1891-1895.....	5.78	7.12	12.64	6.21	7.72	13.70
1896-1900.....	4.65	5.61	10.20	5.23	6.13	11.61
1901-1905.....	4.54	5.29	9.89	5.21	5.94	10.56
1906-1910.....	5.34	5.87	9.42	5.78	6.62	10.09
1901.....	4.61	5.16	9.21	5.11	5.54	9.88
1902.....	4.83	5.51	9.94	5.26	5.89	10.62
1903.....	4.85	5.78	10.54	5.40	6.37	11.29
1904.....	3.63	4.82	10.38	4.73	5.50	11.12
1905.....	4.76	5.19	9.40	5.53	6.40	9.90
1906.....	5.51	5.72	9.52	6.03	6.35	10.20
1907.....	6.12	6.20	10.17	6.65	7.09	10.90
1908.....	5.62	5.79	9.89	6.05	6.60	10.60
1909.....	4.87	5.89	9.30	5.24	6.49	9.96
1910.....	4.59	5.77	8.20	4.92	6.57	8.86
1911.....	4.87	5.20	8.96	5.25	5.36	9.60
1912.....	4.98	6.07	9.08	5.38	6.54	9.73

<sup>1</sup> Data furnished by the Chicago Board of Trade. <sup>2</sup> Including Buffalo charges and tolls prior to 1898.

TABLE 174.—*Meats, packed: Mean railroad freight rates per 100 pounds from Cincinnati to New York, 1881-1912.*

Year.	Rate.	Year.	Rate.	Year.	Rate.
<b>Mean:</b>	<i>Cents.</i>		<i>Cents.</i>		<i>Cents.</i>
1881-1885.....	25.1	1901.....	26.0	1907.....	26.0
1886-1890.....	25.3	1902.....	26.0	1908.....	26.0
1891-1895.....	25.3	1903.....	26.0	1909.....	26.0
1896-1900.....	25.8	1904.....	26.0	1910.....	26.0
1901-1905.....	25.8	1905.....	25.0	1911.....	26.0
1906-1910.....	26.0	1906.....	26.0	1912.....	26.0

TABLE 175.—Live stock and dressed meats: Mean freight rates per 100 pounds from Chicago to New York, by rail, 1881-1912.

Year.	Cattle.	Hogs.	Sheep.	Horses and mules.	Dressed beef.	Dressed hogs.		Year.	Cattle.	Hogs.	Sheep.	Horses and mules.	Dressed beef.	Dressed hogs.	
						Refrigerator cars.	Common cars.							Refrigerator cars.	Common cars.
Mean:	Cts.	Cts.	Cts.	Cts.	Cts.	Cts.	Cts.	1904.	Cts.	Cts.	Cts.	Cts.	Cts.	Cts.	Cts.
1881-1885..	34.6	29.2	30.2	60	56.4	.....	.....	1904.	28	30	30	60	45	45	45
1886-1890..	27.2	29.2	34.6	60	51.0	48.8	46.0	1905.	28	30	30	60	45	45	45
1891-1895..	27.4	27.6	30.0	60	45.0	45.0	45.0	1906.	28	30	30	60	45	45	45
1896-1900..	27.4	29.0	29.0	60	44.0	44.0	44.0	1907.	28	30	30	60	45	45	45
1901-1905..	28.0	30.0	30.0	60	43.8	43.8	43.8	1908.	28	30	30	60	45	45	45
1906-1910..	28.0	30.0	30.0	60	45.0	45.0	45.0	1909.	28	30	30	60	45	45	45
1901.	28.0	30.0	30.0	60	42.9	42.9	42.9	1910.	28	30	30	60	45	45	45
1902.	28.0	30.0	30.0	60	41.2	41.2	41.2	1911.	28	30	30	60	45	45	45
1903.	28.0	30.0	30.0	60	45.0	45.0	45.0	1912.	28	30	30	60	45	45	45

TABLE 176.—Cotton: Mean annual quotations of freight rates per 100 pounds, by coastwise vessels, to New York from New Orleans and Savannah, 1886-1912.<sup>1</sup>

Year.	To New York from—		Year.	To New York from—	
	New Orleans.	Savannah. <sup>2</sup>		New Orleans.	Savannah. <sup>2</sup>
Mean:	Cents.	Cents.		Cents.	Cents.
1886-1890.....	36.0	25.0	1904.....	30.0	20.0
1891-1895.....	33.0	21.3	1905.....	29.0	20.0
1896-1900.....	29.2	19.9	1906.....	25.0	20.0
1901-1905.....	29.8	20.7	1907.....	25.0	20.0
1906-1910.....	25.0	19.9	1908.....	25.0	20.0
1901.....	30.0	23.3	1909.....	25.0	20.0
1902.....	30.0	20.0	1910.....	25.0	<sup>3</sup> 19.6
1903.....	30.0	20.0	1911.....	25.0	18.0
			1912.....	25.0	18.0

<sup>1</sup> Compiled from quotations published in daily newspapers or furnished by steamship agents.

<sup>2</sup> In 1901-1910 the rates from Savannah to New York, which included lighterage in New York Harbor, were about 3 cents per 100 pounds above the rates shown in this table. Rates for 1911 and subsequent years include lighterage.

<sup>3</sup> For shipments of less than 50,000 pounds. Rates, including lighterage in New York Harbor, for shipments of 50,000 pounds and over were, in 1910, 18.4 cents.



TABLE 177.—Compressed cotton: Mean freight rates per 100 pounds from New Orleans and Memphis, by rail, to North Atlantic ports, 1881-1912.

Year.	From New Orleans to—				From Mem- phis to—		Year.	From New Orleans to—				From Mem- phis to—	
	Boston.	New York.	Philadelphia.	Baltimore.	New York.	Boston.		Boston.	New York.	Philadelphia.	Baltimore.	New York.	Boston.
Mean:	<i>Cts.</i>	<i>Cts.</i>	<i>Cts.</i>	<i>Cts.</i>	<i>Cts.</i>	<i>Cts.</i>		<i>Cts.</i>	<i>Cts.</i>	<i>Cts.</i>	<i>Cts.</i>	<i>Cts.</i>	<i>Cts.</i>
1881-1885.	58.2	53.2	52.8	52.2	61.8	66.2	1904.....	55	50	50	50	50.5	50.5
1886-1890.	51.8	46.8	45.2	44.4	50.8	55.6	1905.....	55	50	50	50	40.5	45.5
1891-1895.	53.8	49.6	49.6	49.6	49.8	54.6	1906.....	55	50	50	50	40.5	45.5
1896-1900.	54.4	49.4	49.4	49.4	49.2	54.2	1907.....	55	50	50	50	40.5	45.5
1901-1905.	55.0	50.0	50.0	50.0	48.5	52.5	1908.....	55	50	50	50	42.5	47.5
1906-1910.	55.0	50.0	50.0	50.0	41.7	46.7	1909.....	55	50	50	50	42.5	47.5
1901.....	55.0	50.0	50.0	50.0	50.5	55.5	1910.....	55	50	50	50	42.5	47.5
1902.....	55.0	50.0	50.0	50.0	50.5	55.5	1911.....	55	50	50	50	42.5	47.5
1903.....	55.0	50.0	50.0	50.0	50.5	55.5	1912.....	55	50	50	50	42.5	47.5

TABLE 178.—Grain (except oats), cotton, and lard: Mean monthly quotations of ocean freight rates from United States ports to Liverpool, 1912.

Article and port.	Mean for month—												Mean for year.
	January.	February.	March.	April.	May.	June.	July.	August.	September.	October.	November.	December.	
Grain, except oats (per 60 pounds):	<i>Cents.</i>	<i>Cents.</i>	<i>Cents.</i>	<i>Cents.</i>	<i>Cents.</i>	<i>Cents.</i>	<i>Cents.</i>	<i>Cents.</i>	<i>Cents.</i>	<i>Cents.</i>	<i>Cents.</i>	<i>Cents.</i>	<i>Cents.</i>
Boston.....	6.7	7.2	7.6	7.6	6.2	3.9	3.7	6.2	9.8	10.9	11.3	10.5	7.6
New York.....	6.8	7.9	7.6	8.0	6.2	4.6	4.2	5.5	9.7	11.0	11.0	10.0	7.7
Baltimore.....	6.3	7.4	9.4	10.0	.....	.....	.....	6.8	7.4	11.3	11.3	12.6	9.2
New Orleans... ..	9.2	10.9	11.6	10.7	9.4	7.4	7.4	12.6	.....	14.7	15.2	15.2	11.3
Galveston.....	8.2	9.8	9.8	9.4	9.0	9.0	7.9	10.5	11.2	13.1	13.5	13.5	10.4
Cotton (per 100 pounds):													
Boston.....	24.7	30.0	30.0	26.2	24.2	20.0	21.2	30.0	40.6	40.0	40.0	35.0	30.2
New York.....	40.0	40.0	36.9	33.8	29.5	25.5	25.0	31.2	42.5	50.0	45.0	42.5	36.9
Baltimore.....	32.5	38.8	.....	35.0	30.0	30.0	30.0	36.0	46.2	50.0	50.0	47.5	38.7
New Orleans... ..	47.8	55.0	53.3	50.0	43.0	40.0	40.0	50.2	65.0	64.7	66.0	57.0	52.7
Galveston.....	45.0	47.0	48.0	47.0	44.5	40.0	40.0	50.0	55.0	57.5	61.5	61.5	49.8
Lard, small packages (per 100 pounds):													
Boston.....	25.3	25.3	25.3	25.3	25.3	25.3	25.3	25.3	25.3	25.3	25.3	25.3	25.3
New York.....	25.3	25.3	25.3	25.3	25.3	25.3	25.3	25.3	25.3	25.3	25.3	25.3	25.3
Baltimore.....	25.3	25.3	.....	25.3	25.3	25.3	25.3	25.3	25.3	25.3	25.3	25.3	25.3
New Orleans... ..	35.0	35.0	35.0	35.0	35.0	35.0	35.0	36.2	48.0	42.0	.....	.....	37.1

TABLE 179.—Grain (except oats) and cotton: Mean annual quotations of ocean freight rates per 100 pounds from various United States ports to Europe, 1886-1912.<sup>1</sup>

Calendar year.	Grain (except oats).				Cotton.					
	To Liverpool from—			To Cork for orders, from San Francisco.	To Liverpool from—			To Bremen from—		
	New York.	Balti-more. <sup>2</sup>	New Or-leans.		New York.	Savan-nah.	New Or-leans.	New York.	Savan-nah.	New Or-leans.
Mean:	Cents.	Cents.	Cents.	Cents.	Cents.	Cents.	Cents.	Cents.	Cents.	Cents.
1886-1890.....	10.4	11.8	15.5	32.1	31.4	67.2	60.7	45.4	72.2	68.6
1891-1895.....	8.8	9.9	12.2	31.2	25.7	44.9	40.2	33.1	49.5	46.7
1896-1900.....	10.7	11.5	14.8	29.1	23.5	44.8	41.0	31.7	42.8	47.9
1901-1905.....	4.8	5.8	8.7	26.2	14.2	28.2	32.2	21.6	26.5	33.3
1906-1910.....	5.5	5.8	10.3	25.3	16.0	28.4	31.8	20.0	28.7	32.6
1901.....	4.4	6.3	8.7	41.5	13.4	31.4	32.5	23.2	30.1	37.6
1902.....	5.0	6.2	7.2	32.1	12.5	26.6	28.7	18.3	24.1	39.5
1903.....	5.0	5.4	8.5	18.5	14.8	26.8	34.0	23.3	26.1	33.8
1904.....	3.9	4.8	8.8	15.8	13.7	28.4	31.4	21.9	25.4	31.9
1905.....	5.7	6.4	10.6	23.2	16.6	27.8	33.8	21.2	26.6	32.7
1906.....	5.0	6.1	11.4	25.0	17.0	30.4	34.2	21.3	31.0	38.2
1907.....	6.1	6.8	11.8	24.8	18.6	31.3	35.9	20.5	32.4	36.6
1908.....	5.5	6.5	10.1	25.6	13.7	31.3	29.9	21.0	32.0	30.6
1909.....	5.7	5.1	8.8	25.5	13.4	25.4	28.0	17.7	25.1	28.0
1910.....	5.2	4.5	9.3	25.5	17.1	22.8	31.1	19.3	23.1	31.2
1911.....	7.0	7.1	11.0	24.2	20.2	29.2	35.3	26.5	29.6	36.5
1912.....	4 12.8	4 15.3	25.4	30.8	36.9	45.9	52.7	40.5	45.7	55.1

<sup>1</sup> The rates in this table for grain (except oats) from New York were computed from data in the annual reports of the New York Produce Exchange, except for the last year; from Baltimore, from reports of the Baltimore Chamber of Commerce. All other figures were computed from rates quoted in newspapers and in circulars issued by freight brokers and transportation companies.

<sup>2</sup> Mean of daily quotations.

<sup>3</sup> Mean, 1891, 1893-1895.

<sup>4</sup> Preliminary.

TABLE 180.—Grain (except oats), flour, and provisions: Mean rates per 100 pounds through from Chicago to European ports by all-rail to seaboard and thence by steamers, 1883-1912.<sup>1</sup>

Year.	Grain.			Sacked flour.			Provisions.										
	Glasgow.	Liverpool.	London.	Glasgow.	Liverpool.	London.	Amsterdam.	Antwerp.	Bordeaux.	Copenhagen.	Glasgow.	Hamburg.	Liverpool.	London.	Rotterdam.	Stettin.	Stockholm.
Mean:	Cts.	Cts.	Cts.	Cts.	Cts.	Cts.	Cts.	Cts.	Cts.	Cts.	Cts.	Cts.	Cts.	Cts.	Cts.	Cts.	Cts.
1883-1885.....	29.4	36.8	29.8	36.0	33.3	35.0	56.5	53.5	37.0	58.5	46.5	53.4	44.2	44.7	52.9	60.2	67.9
1886-1890.....	37.7	45.6	38.4	39.9	36.1	40.3	56.0	50.9	63.4	57.9	53.4	54.6	46.3	53.7	56.0	58.2	64.4
1891-1895.....	36.9	34.5	36.2	38.2	36.1	37.6	53.0	49.2	64.7	58.1	50.8	51.5	46.5	49.3	52.6	58.1	68.3
1896-1900.....	33.8	32.1	32.8	35.5	33.4	35.4	50.9	50.4	63.4	56.1	51.0	50.0	45.2	49.0	50.9	56.1	66.9
1901-1905.....	22.5	20.9	22.1	23.6	23.0	24.1	42.9	45.9	53.9	47.0	44.2	44.4	37.8	42.6	42.7	46.9	50.4
1906-1910.....	18.3	18.8	19.0	22.4	20.6	22.6	46.4	48.3	55.1	53.3	46.6	48.7	43.0	46.8	46.0	51.7	54.9
1906.....	19.2	18.8	19.2	23.6	20.5	22.5	46.0	47.6	53.0	51.0	45.6	49.0	41.0	46.3	46.0	50.0	53.5
1907.....	19.7	19.2	20.5	23.9	21.2	23.6	45.0	45.6	55.0	51.0	46.9	46.0	40.8	46.3	45.0	49.2	53.0
1908.....	18.6	19.0	19.5	22.1	20.8	23.2	45.0	49.6	55.0	54.0	46.9	49.6	42.6	46.3	45.0	51.8	54.7
1909.....	18.0	18.9	18.2	21.0	20.7	21.5	48.0	49.4	55.0	55.3	46.9	49.1	45.4	47.5	47.0	53.9	56.7
1910.....	15.9	18.2	17.8	21.5	19.8	22.0	48.0	49.4	57.5	55.3	46.9	50.0	45.4	47.6	47.0	53.9	56.7
1911.....	20.0	19.8	20.9	25.0	23.0	25.2	49.0	49.4	57.5	57.0	46.9	50.0	45.4	47.6	48.0	55.6	59.8
1912.....	21.0	25.6	26.3	30.0	29.0	29.2	61.0	52.4	63.0	71.3	52.5	62.0	48.2	50.4	61.0	69.9	75.0

<sup>1</sup> Data furnished by Chicago Board of Trade.

<sup>2</sup> Mean for 1884 and 1885.

<sup>3</sup> Mean for 1884, 1885, and 10 months in 1883.

<sup>4</sup> Mean for 1887, 1888, 1889, 1890, and January, 1886.

<sup>5</sup> Mean for 1886, 1887, 1888, 1890.

TABLE 181.—Average freight charge on Pacific coast wheat per ton per mile, over selected routes, in 1910.

[Based upon tons of 2,000 pounds and statute miles.]

Route.	Cents per ton per mile.
By wagon, from farms to shipping points (in 1906):	
Washington.....	24.841
Idaho.....	20.952
Oregon.....	17.388
California.....	14.331
By electric railroad:	
From Salem, Oreg., to Portland, Oreg.....	3.219
From Marysville, Cal., to Sacramento, Cal.....	2.392
From Chico, Cal., to Sacramento, Cal.....	2.205
From Moscow, Idaho, to Spokane, Wash.....	1.429
By steam railroad:	
From Ellensburg, Wash., to Tacoma, Wash.....	1.870
From Merced, Cal., to San Francisco, Cal.....	1.513
From Lewiston, Idaho, to Portland, Oreg.....	.952
From Portland, Oreg., to San Francisco, Cal.....	.402
By river:	
From The Dalles, Oreg., to Portland, Oreg.....	1.316
From Sacramento, Cal., to San Francisco, Cal.....	1.000-1.200
From Red Bluff, Cal., to Sacramento, Cal.....	1.020
From Lewiston, Idaho, to Portland, Oreg.....	.823-.900
By coastwise steamships:	
From Seattle, Wash., to Skagway, Alaska.....	.505
From Portland, Oreg., to San Francisco, Cal.....	.166-.266
By ocean steamships:	
From Tacoma, Wash., to Liverpool, England, via Magellan Straits.....	.0363-.0373
By sail vessels:	
From Tacoma, Wash., to Liverpool, England, via Cape Horn.....	.0210-.0294

TABLE 182.—Mileage operated by railroads making organized efforts to promote agriculture.<sup>1</sup>

Group. <sup>2</sup>	Total miles operated by all railroads in United States.	Miles operated by railroads making organized efforts to—					
		Increase the number of farmers.		Promote agricultural education.		Increase the number of farmers or promote agricultural education.	
		Miles.	Per cent of total.	Miles.	Per cent of total.	Miles.	Per cent of total.
I.....	8,240	5,655	68.6	6,906	83.8	6,906	83.8
II.....	24,521	1,733	7.1	16,947	69.1	16,947	69.1
III.....	26,624	6,997	26.3	15,490	58.2	15,490	58.2
IV.....	15,221	10,746	70.6	10,965	72.0	10,965	72.0
V.....	30,076	23,664	78.7	22,857	76.0	23,838	79.3
VI.....	52,379	32,080	61.2	30,398	58.0	41,572	79.4
VII.....	14,099	12,525	88.8	11,466	81.3	12,525	88.8
VIII.....	34,653	29,403	84.8	30,440	87.8	30,805	88.9
IX.....	19,405	14,067	72.5	11,615	59.9	14,766	76.1
X.....	24,774	17,634	71.2	17,072	68.9	17,634	71.2
United States.....	249,992	154,504	61.8	174,156	69.7	191,448	76.6

<sup>1</sup> Compiled from reports of the Interstate Commerce Commission on Statistics of Railways in the United States. Figures refer to June 30, 1910, and railroads are classified according to the agricultural promotion work that was reported to be in progress in the year ending June 30, 1912.

<sup>2</sup> Group I comprises the railroads of the New England States; Group II, New York (east of Buffalo), Pennsylvania (east of Pittsburgh), New Jersey Delaware, Maryland, and northern part of West Virginia; Group III, New York (west of Buffalo), Pennsylvania (west of Pittsburgh), Ohio, Indiana, and the southern peninsula of Michigan; Group IV, Virginia, central and southern West Virginia, North Carolina, and South Carolina; Group V, Kentucky, Tennessee, Georgia, Florida, Alabama, Mississippi, and Louisiana (east of the Mississippi River); Group VI, northern peninsula of Michigan, Wisconsin, Illinois, Minnesota, Iowa, Missouri (north of the Missouri River), North Dakota (east of the Missouri River), and South Dakota (east of the Missouri River); Group VII, North Dakota (west of the Missouri River), South Dakota (west of the Missouri River), Nebraska, Montana, Wyoming, and northern Colorado; Group VIII, Missouri (south of Missouri River), Arkansas, Kansas, Oklahoma, central and southern Colorado, northeastern New Mexico, and the "panhandle" of Texas; Group IX, Texas (except the "panhandle") and southeastern New Mexico; Group X, Idaho, Utah, Nevada, western New Mexico, Arizona, Oregon, Washington, and California.

TABLE 183.—Number of farms in counties containing railroads engaged in organized efforts to promote agriculture.<sup>1</sup>

Geographic division.	Total number of farms in United States.	Number of farms in counties in which were located railroads engaged in organized efforts to—					
		Increase the number of farmers.		Promote agricultural education.		Increase the number of farmers or promote agricultural education.	
		Number of farms.	Per cent of total.	Number of farms.	Per cent of total.	Number of farms.	Per cent of total.
North Atlantic.....	657, 181	422, 788	64.3	638, 469	97.2	638, 470	97.2
South Atlantic.....	1, 111, 881	924, 626	83.2	1, 059, 571	95.3	1, 060, 659	95.4
North Central:							
East of Mississippi River..	1, 123, 489	650, 416	57.9	1, 044, 905	93.0	1, 074, 587	95.6
West of Mississippi River..	1, 109, 948	1, 087, 096	97.9	1, 060, 426	94.6	1, 090, 336	98.2
South Central:							
East of Mississippi River..	1, 042, 480	936, 914	89.9	920, 360	88.3	936, 914	89.9
West of Mississippi River..	943, 186	899, 460	95.4	895, 349	94.9	907, 801	96.2
Rocky Mountain.....	183, 446	165, 075	90.0	165, 556	90.2	168, 681	92.0
Pacific coast.....	189, 891	179, 499	94.5	179, 499	94.5	179, 499	94.5
United States.....	6, 361, 502	5, 265, 874	82.8	5, 954, 135	93.6	6, 056, 947	95.2

<sup>1</sup> The figures in this table are based upon the census of 1910, and the counties are grouped according to the railroad's agricultural promotion work that was reported to be in progress in the year ending June 30, 1912.

# IMPORTS AND EXPORTS OF AGRICULTURAL PRODUCTS.<sup>1</sup>

TABLE 184.—*Agricultural imports of the United States during the five years ending June 30, 1912.*

Article imported.	1908		1909		1910		1911		1912	
	Quantity.	Value.	Quantity.	Value.	Quantity.	Value.	Quantity.	Value.	Quantity.	Value.
<b>ANIMAL MATTER.</b>										
Animals, live:										
Cattle—										
For breeding purposes, number.....	3,188	\$149,142	3,049	\$140,713	2,611	\$291,139	2,441	\$362,220	2,129	\$305,222
Other.....number..	89,168	1,358,168	136,135	1,858,709	193,327	2,708,685	180,482	2,590,857	316,243	4,500,352
Total cattle.....do....	92,356	1,507,310	139,184	1,999,422	195,938	2,999,824	182,923	2,953,077	318,372	4,805,574
Horses—										
For breeding purposes...do....	3,562	1,325,784	4,953	1,658,640	7,867	2,660,241	6,331	2,055,413	3,849	1,579,377
Other.....do.....	1,925	278,608	2,131	348,636	3,753	635,781	3,262	636,656	2,758	343,648
Total horses.....do....	5,487	1,604,392	7,084	2,007,276	11,620	3,296,022	9,593	2,692,071	6,607	1,923,025
Sheep—										
For breeding purposes...do....	5,609	104,509	4,860	89,272	6,335	135,019	5,341	116,277	2,268	29,106
Other.....do.....	219,156	978,097	97,803	413,368	119,817	561,860	48,114	261,348	21,380	128,151
Total sheep.....do....	224,765	1,082,606	102,663	502,640	126,152	696,879	53,455	377,625	23,588	157,257
All other, including fowls.....	583,151		528,333		846,945		828,188		694,609	
Total live animals.....	4,777,459		5,037,671		7,839,670		6,850,904		7,580,555	
Beeswax.....pounds..	671,526	194,769	764,937	231,559	972,145	282,905	902,904	270,112	1,076,741	328,752
Dairy products:										
Butter.....do....	780,608	182,897	646,320	141,917	1,360,245	298,023	1,007,826	247,961	1,025,668	237,154
Cheese.....do....	32,530,830	5,586,796	35,548,143	5,806,154	40,817,524	7,053,570	45,568,797	7,920,244	46,542,307	8,807,249
Cream.....gallons..	(?)	(?)	(?)	(?)	731,783	577,715	2,332,875	1,873,293	1,120,427	923,779
Milk.....do.....	(?)	1,496	(?)	23,428	(?)	63,339	(?)	75,090	(?)	61,671
Total dairy products.....	5,781,099		6,031,499		7,992,647		10,116,588		10,029,853	
Eggs.....dozens....	231,939	25,850	288,650	36,937	818,267	110,738	1,573,394	225,744	973,053	147,173
Egg yolks.....pounds..	(?)	10,845	(?)	6,232	869,923	56,121	433,405	30,798	43,822	4,430

Feathers and downs, crude:										
Ostrich.....		4,360,721		5,507,974		7,113,773		5,865,830		3,806,696
Other.....										1,228,645
Fibers, animal:										
Silk—										
Cocoons..... pounds..	187	292	14,016	3,931	48,661	14,426	163,867	74,261	82,456	51,073
Raw, or as reeled from the coo- coon..... pounds.....	15,424,041	63,665,534	23,333,750	78,830,568	20,363,327	65,424,784	22,379,998	72,713,984	21,609,520	67,173,382
Waste..... do.....	1,237,904	881,077	1,840,191	1,069,087	3,045,235	1,690,393	4,122,226	2,210,020	4,892,986	2,317,217
Total silk..... do.....	16,662,132	64,546,903	25,187,957	79,903,586	23,457,223	67,129,603	26,666,091	74,998,265	26,584,900	69,541,672
Wool, and hair of the camel, goat, alpaca, and like animals—										
Class 1, clothing..... pounds..	45,798,303	10,278,199	142,580,993	29,455,598	111,592,978	27,231,052	40,104,845	9,044,321	71,203,329	15,106,193
Class 2, combing..... do.....	13,332,540	3,624,617	21,952,259	4,591,559	31,614,235	7,931,145	12,456,468	3,280,683	15,557,664	3,802,034
Class 3, carpet..... do.....	66,849,681	9,762,122	101,876,052	11,124,837	120,721,019	16,058,647	85,086,328	10,903,001	106,639,720	14,170,115
Total wool..... do.....	125,980,524	23,664,938	266,409,304	45,171,994	263,928,232	51,220,844	137,647,641	23,228,005	193,400,713	33,078,342
Total animal fibers..... do.....	142,642,656	88,211,841	291,597,261	125,075,580	287,385,455	118,350,447	164,313,732	98,226,270	219,985,675	102,620,014
Gelatin..... do.....	( <sup>2</sup> )	( <sup>2</sup> )	1,247,910	387,232	1,249,856	386,696	1,312,979	387,525	783,668	181,461
Glue..... do.....	6,731,943	629,032	6,610,894	655,127	8,821,554	861,888	8,335,178	806,208	7,534,322	776,696
Honey..... gallons.....	211,992	98,425	145,691	60,884	103,640	52,968	112,553	62,942	115,040	62,684
Packing-house products:										
Bladders, other than fish.....		4,905		7,354		( <sup>2</sup> )		38,129		41,954
Blood, dried.....		40,023		91,705		221,587		446,698		215,255
Bones, cleaned.....		( <sup>2</sup> )		( <sup>2</sup> )		( <sup>2</sup> )		( <sup>2</sup> )		18,512
Bones, hoofs, and horns.....		733,798		777,357		1,067,911		1,168,924		1,038,653
Bristles—										
Crude, unsorted..... pounds..	7,710	7,620	10,129	7,637	37,927	12,987	11,562	9,803	26,174	14,796
Sorted, bunched, or prepared, pounds.....	2,614,783	2,090,157	2,884,372	2,583,482	3,992,520	3,111,872	3,542,913	2,970,481	3,435,801	3,032,231
Total bristles..... pounds..	2,622,493	2,097,777	2,894,501	2,591,119	4,030,447	3,124,859	3,554,475	2,980,284	3,461,975	3,047,027
Grease.....		1,103,081		1,489,764		1,522,327		1,714,757		963,205
Gut.....		113,861		128,165		149,103		153,779		132,929
Hair—										
Horse..... pounds.....	( <sup>2</sup> )	3,770,658	( <sup>2</sup> )	3,750,524	5,410,930	2,106,730	4,542,930	1,683,820	5,381,730	2,308,319
Other animal..... do.....					13,349,752	1,065,061	12,992,338	956,775	10,795,253	1,025,421
Hide cuttings and other glue stock.....		1,265,382		1,301,956		1,605,432		1,633,042		1,707,171

<sup>1</sup> Forest products come within the scope of the Department of Agriculture and are therefore included in alphabetical order in these tables.

<sup>2</sup> Not stated.

<sup>3</sup> Including human hair.

TABLE 184.—Agricultural imports of the United States during the five years ending June 30, 1912—Continued.

Article imported.	1908		1909		1910		1911		1912	
	Quantity.	Value.	Quantity.	Value.	Quantity.	Value.	Quantity.	Value.	Quantity.	Value.
ANIMAL MATTER—continued.										
Packing-house products—Continued.										
Hides and skins, other than furs—										
Buffalo hides—										
Dry.....pounds..	(1)	(1)	(1)	(1)	(1)	(1)	{ 3,425,307	{ \$517,859	{ 4,906,362	{ \$732,465
Green or pickled.....do....							{ 174,079	{ 24,533	{ 82,313	{ 8,789
Calfskins—										
Dry.....do.....	(2)	(2)	(2)	(2)	75,593,451	\$17,922,051	{ 23,522,298	{ 7,783,890	{ 41,992,100	{ 14,697,085
Green or pickled.....do....							{ 36,261,052	{ 6,411,789	{ 63,260,389	{ 11,833,908
Cattle hides—										
Dry.....do.....	98,353,249	\$12,044,435	192,252,083	\$23,795,602	318,003,538	46,700,139	{ 54,630,170	{ 10,115,816	{ 78,131,330	{ 15,161,229
Green or pickled.....do....							{ 95,497,626	{ 11,493,614	{ 172,881,183	{ 23,244,292
Goatskins—										
Dry.....do.....	63,640,758	17,325,126	104,048,244	26,023,914	115,844,758	30,837,590	{ 64,337,587	{ 18,796,014	{ 69,143,153	{ 19,930,142
Green or pickled.....do....							{ 22,576,255	{ 2,964,543	{ 26,197,550	{ 3,366,413
Horse and ass skins—										
Dry.....do.....	(2)	(2)	(2)	(2)	19,512,397	3,080,484	{ 4,550,742	{ 1,011,433	{ 7,194,331	{ 1,474,590
Green or pickled.....do....							{ 5,703,531	{ 570,740	{ 5,674,741	{ 597,397
Sheepskins—										
Dry.....do.....	(2)	(2)	48,906,326	8,276,637	67,406,131	11,289,158	{ 18,787,098	{ 3,532,800	{ 25,644,846	{ 4,977,912
Green or pickled.....do....							{ 36,929,941	{ 5,416,263	{ 34,755,463	{ 4,858,304
Other.....do.....	120,770,918	25,400,575	99,347,672	20,391,171	12,258,753	2,418,414	{ 8,495,709	{ 1,805,686	{ 7,904,337	{ 1,593,801
Total hides and skins .do....	282,764,925	54,770,136	444,554,325	78,487,324	608,619,028	112,247,836	374,891,395	70,504,980	537,768,098	102,476,327
Meat—										
Sausages, bologna.....do....	520,770	108,367	560,873	129,568	555,524	127,274	666,988	140,535	971,775	182,982
Other, including meat extracts..		775,713		667,367		1,086,966		1,201,520		1,176,010
Total meat.....		884,080		796,935		1,214,240		1,342,055		1,358,992
Oils, animal.....gallons..										
Oleo stearin.....pounds..	85,964	16,965	(4)	(4)	(4)	(4)	(4)	(4)	(4)	(4)
Rennets.....pounds..	1,434,845	135,739	3,895,254	411,485	8,144,485	952,628	5,715,348	592,119	4,913,090	448,950
Sausage casings.....pounds..	(4)	151,028	(4)	97,684	(4)	92,459	(4)	111,609	(4)	102,142
Other.....do.....		2,182,036		2,258,648		2,604,895		2,751,327		2,385,715
		29,968		34,722		(2)		(2)		(2)
Total packing-house products.		66,299,437		92,224,742		127,975,068		86,078,298		117,270,572
Total animal matter.....		170,389,478		235,255,437		271,022,926		208,921,279		244,037,531

VEGETABLE MATTER.										
Argols, or wine lees.....pounds..	26,738,834	2,305,185	32,115,646	2,641,867	28,182,956	2,220,687	29,175,133	2,938,337	23,661,078	2,225,180
Breadstuffs. (See Grain and grain products.)										
Broom corn.....long tons..	2	516	1,880	163,645	7,659	933,878	620	54,481	1,346	157,969
Cider.....gallons.....	9,764	11,113	9,704	10,298	7,791	7,606	(4)	(4)	(4)	(4)
Cocoa and chocolate:										
Cocoa—										
Crude, and leaves and shells of, pounds.....	82,831,242	14,257,250	129,854,749	14,850,328	108,668,070	11,376,061	138,058,341	14,552,879	145,968,945	15,931,556
Prepared, or manufactured, pounds.....	1,016,990	311,661	1,287,109	372,195	1,107,203	316,118	(e)	(e)	(e)	(e)
Total cocoa.....pounds..	83,848,232	14,568,911	131,141,858	15,222,523	109,775,273	11,692,179	138,058,341	14,552,879	145,968,945	15,931,556
Chocolate.....do.....	2,756,452	715,131	1,519,073	339,795	1,295,561	274,247	2,912,536	708,056	2,816,901	658,844
Total cocoa and chocolate, pounds.....	86,604,684	15,284,042	132,660,931	15,562,318	111,070,834	11,966,426	140,970,877	15,260,935	148,785,846	16,590,400
Coffee.....pounds.....	890,640,057	67,688,106	1,049,868,768	79,112,129	871,469,516	69,194,353	875,366,797	90,567,788	885,201,247	117,826,543
Coffee substitutes:										
Chicory root—										
Raw, unground.....do....	2,170,633	34,330	6,137,303	99,389	2,595,942	62,410	5,393,373	111,416	5,401	125
Roasted, ground, or otherwise prepared.....pounds..	502,792	21,311	644,466	24,947	288,866	11,618	498,441	25,084	679,511	33,530
Total chicory root.....do....	2,673,425	55,641	6,781,769	124,336	2,884,808	74,028	5,891,814	136,500	684,912	33,655
Other.....do.....	431,603	27,621	499,633	28,941	200,008	17,034	169,201	19,816	70,810	14,275
Total coffee substitutes.do....	3,105,028	83,262	7,281,402	153,277	3,084,816	91,062	6,061,015	* 156,316	755,722	47,930
Curry and curry powder.....		14,350		10,276		(4)		11,333		10,441

<sup>1</sup> Included in "Cattle hides."

<sup>2</sup> Included in "Other" hides and skins other than furs.

<sup>3</sup> Except sheepskins with the wool on.

<sup>4</sup> Not stated.

<sup>5</sup> Included in "Other, including meat extracts."

<sup>6</sup> Included in "Chocolate."



TABLE 184.—Agricultural imports of the United States during the five years ending June 30, 1912—Continued.

Article imported.	1908		1909		1910		1911		1912	
	Quantity.	Value.	Quantity.	Value.	Quantity.	Value.	Quantity.	Value.	Quantity.	Value.
VEGETABLE MATTER—continued.										
Fibers, vegetable:										
Cotton..... pounds..	71,072,855	\$14,172,241	86,518,024	\$13,622,802	86,037,691	\$15,816,138	113,768,313	\$24,776,320	109,780,071	\$20,217,581
Flax..... long tons..	9,528	2,514,680	9,870	2,542,256	12,761	3,536,062	7,792	2,668,538	10,900	3,778,501
Hemp..... do.....	6,213	1,056,805	5,208	799,164	6,423	1,039,833	5,278	988,338	5,007	1,100,273
Istle, or Tampico fiber..... do.....	10,174	893,273	9,610	675,887	9,272	645,526	6,874	469,503	9,835	776,351
Jute and jute butts..... do.....	107,533	6,504,920	156,685	7,216,307	68,155	3,728,448	65,238	4,718,599	101,001	7,183,385
Kapoc..... do.....	(1)	(1)	(1)	(1)	(1)	(1)	2,070	465,774	2,099	570,084
Manila..... do.....	52,467	8,974,617	61,902	7,156,091	93,253	10,517,100	74,308	8,622,491	68,536	8,000,865
New Zealand flax..... do.....	(1)	(1)	(1)	(1)	3,353	362,888	2,679	294,388	5,364	483,310
Sisal grass..... do.....	103,994	14,047,369	91,451	10,215,887	99,966	11,440,521	117,727	12,092,564	114,467	11,866,843
Other..... do.....	13,575	1,471,419	10,719	1,142,761	12,248	1,148,461	8,468	482,055	9,270	703,254
Total vegetable fibers.....		49,665,324		43,371,155		48,234,977		55,528,570		54,680,447
Flowers, natural.....		42,821		41,187		43,818		45,058		15,018
Forest products:										
Charcoal..... bushels..	472,670	37,167	886,297	46,660	(2)	(2)	(2)	17,363	(2)	29,586
Cinchona bark..... pounds..	3,983,825	368,419	3,502,423	263,112	3,300,483	242,087	3,826,048	297,634	2,891,823	233,323
Cork wood or cork bark.....		2,092,732		2,016,551		3,152,280		4,274,810		3,242,319
Dyewoods, and extracts of—										
Dyewoods—										
Logwood..... long tons..	21,594	244,460	17,874	166,371	32,368	368,448	(2)	(2)	39,571	476,983
Other..... do.....	(2)	55,940	(2)	45,760	(2)	(2)	(2)	(2)	3,141	47,315
Total dyewoods.....	(2)	300,400	(2)	212,131	32,368	368,448	(2)	(2)	42,712	524,298
Extracts and decoctions of, pounds.....	3,959,049	238,649	3,519,733	232,879	3,273,393	197,929	10,556,961	412,196	9,297,084	353,245
Total dyewoods, and extracts of.....		539,049		445,010		566,377		412,196		877,543
Guayule plant..... pounds..	1,524,401	28,583	945,789	18,490	1,146,193	33,462	149,624	6,650	2,000	45

								( <sup>1</sup> )		( <sup>2</sup> )
Gums—										
Arabic.....do.....	4,890,897	348,883	4,158,958	275,987	5,451,181	315,154	.....			
Camphor—										
Crude.....do.....	2,814,299	1,365,269	1,990,499	602,530	3,026,648	921,926	3,726,319	1,118,586	2,154,646	682,669
Refined.....do.....	( <sup>2</sup> )	( <sup>2</sup> )	451,362	158,297	477,269	179,965	478,422	161,878	244,295	91,429
Chicle.....do.....	6,089,607	2,027,148	5,450,139	1,987,112	6,793,821	2,547,339	6,508,208	2,899,086	7,782,005	3,127,004
Copal, kauri, and damar.....do.....	24,966,693	2,813,515	24,861,428	2,388,458	29,357,579	2,961,800	23,021,822	2,080,832	25,115,739	2,016,474
Gambier, or terra japonica, pounds.....	26,681,791	894,752	30,992,245	1,313,997	25,572,655	1,255,296	18,764,507	970,158	21,002,795	1,031,047
India rubber, gutta percha, etc.—										
Balata.....pounds..	584,552	276,756	1,157,018	522,872	399,003	196,878	878,305	624,702	1,517,066	984,012
Guayule gum.....do.....	( <sup>4</sup> )	( <sup>4</sup> )	( <sup>4</sup> )	( <sup>4</sup> )	( <sup>4</sup> )	( <sup>4</sup> )	19,749,522	10,443,157	14,238,625	6,463,787
Guta-joolatong, or East Indian gum.....pounds..	22,803,303	1,039,776	24,826,296	852,372	52,392,444	2,419,223	51,420,872	2,872,633	48,795,268	2,255,050
Gutta-percha.....do.....	188,610	100,305	255,559	82,136	784,501	167,873	1,648,921	390,548	1,204,406	225,797
Indian rubber.....do.....	62,233,160	36,613,185	88,359,895	61,709,723	101,044,681	101,078,825	72,046,260	76,244,603	110,210,173	93,013,255
Total India rubber, etc., pounds.....	85,809,625	38,030,022	114,598,768	63,167,103	154,620,629	103,862,799	145,743,880	90,575,643	171,965,538	102,941,901
Shellac.....pounds..	13,361,932	4,143,974	19,185,137	3,889,533	29,402,182	3,877,707	15,494,940	2,306,262	18,745,771	2,296,263
Other.....	939,952	.....	1,393,476	.....	.....	1,444,938	.....	1,862,874	.....	1,943,405
Total gums.....	.....	50,563,515	.....	75,176,493	.....	117,366,924	.....	101,975,319	.....	114,130,192
Ivory, vegetable.....pounds..	14,536,288	375,535	20,002,909	609,062	27,066,716	1,104,924	20,851,466	772,065	23,076,847	789,062
Naval stores—										
Tar and pitch (of wood)....barrels..	2,523	9,797	1,018	5,150	( <sup>2</sup> )	( <sup>2</sup> )	1,719	10,246	679	6,227
Turpentine, spirits of.....gallons..	76,743	29,210	51,137	17,538	127,090	54,330	204,321	107,978	60,913	22,895
Total naval stores.....	.....	39,007	.....	22,688	.....	54,330	.....	118,224	.....	29,032
Palm leaf, natural.....	.....	36,855	.....	17,354	.....	28,428	.....	23,040	.....	32,641
Tanning materials:										
Hemlock bark.....cords..	8,868	43,890	20,373	126,560	16,450	95,667	( <sup>5</sup> )	( <sup>5</sup> )	( <sup>5</sup> )	( <sup>5</sup> )
Mangrove bark.....long tons..	15,192	310,745	12,263	250,409	16,089	402,853	( <sup>5</sup> )	( <sup>5</sup> )	21,779	483,920
Quebracho, extract of.....pounds..	79,186,787	2,260,364	102,004,981	2,740,530	95,183,073	3,021,902	92,039,253	3,030,799	71,635,043	2,320,036
Quebracho wood.....long tons..	48,871	612,971	66,113	731,795	80,210	1,058,647	66,617	984,841	68,174	982,315
Sumac, ground.....pounds..	8,576,091	227,611	10,974,613	293,249	13,632,861	299,170	( <sup>2</sup> )	( <sup>2</sup> )	12,498,376	235,154
Other.....	.....	125,378	.....	177,716	.....	132,847	.....	698,673	.....	268,821
Total tanning materials.....	.....	3,580,959	.....	4,320,259	.....	5,011,086	.....	4,714,313	.....	4,290,246

<sup>1</sup> Included in "Other" vegetable fibers.  
<sup>2</sup> Not stated.

<sup>3</sup> Included in "Other" gums.  
<sup>4</sup> Included in "India rubber."

<sup>5</sup> Included in "Other," tanning materials.

TABLE 184.—Agricultural imports of the United States during the five years ending June 30, 1912—Continued.

Article imported.	1908		1909		1910		1911		1912	
	Quantity.	Value.	Quantity.	Value.	Quantity.	Value.	Quantity.	Value.	Quantity.	Value.
<b>VEGETABLE MATTER—continued.</b>										
<b>Tanning materials—Continued.</b>										
Wood, not elsewhere specified—										
Brier root or brierwood and ivy or laurel root.....		(1)		(1)		\$441,347		\$321,060		\$358,111
Chair cane or reed.....		(2)		(2)		246,475		460,573		575,221
Cabinet woods, unsawed—										
Cedar.....M feet.....		(3)		(3)	19,294	1,028,588	18,172	995,968	15,035	807,699
Mahogany.....do.....	41,678	\$2,566,954	39,828	\$2,479,976	44,524	3,224,152	43,914	3,171,398	43,194	3,038,043
Other.....do.....		1,464,907		1,406,318		721,084		842,970		1,107,975
Total cabinet woods.....		4,031,861		3,886,294		4,973,824		5,010,336		4,953,717
Logs and round timber.M feet..	131,348	1,264,439	155,095	1,510,767	177,490	1,746,472	173,906	1,815,120	155,007	1,593,099
Lumber—										
Boards, deals, planks, and other sawed lumber, M feet.....	791,288	15,212,788	846,024	15,946,755	1,054,416	19,372,215	872,374	16,148,980	905,275	15,802,789
Laths.....M.....		(4)		(4)	722,423	1,804,139	677,770	1,693,340	646,662	1,619,919
Shingles.....do.....	988,081	2,379,242	1,058,363	2,500,398	762,798	1,759,397	642,582	1,387,743	514,657	1,205,327
Other.....do.....		2,665,428		2,452,888		1,185,153		1,553,760		1,175,342
Total lumber.....		20,257,458		20,900,041		24,120,904		20,783,823		19,808,377
Pulp wood—										
Peeled.....cords.....	923,503	4,989,919	727,104	4,333,905	1,000,342	6,392,023	447,819	2,683,913	484,277	2,928,768
Rossed.....do.....							232,749	1,800,555	238,242	1,910,283
Rough.....do.....							189,387	1,080,805	178,751	995,777
Rattan and reeds.....do.....		(1)		(1)		738,214		925,269		898,552
All other.....do.....		2,214,268		1,724,177				838,140		633,109
Total wood, n. e. s.....		32,757,945		32,355,184		39,543,885		35,719,594		34,650,014

<b>Wood pulp—</b>										
<b>Chemical—</b>										
Bleached.....pounds..	532,031,360	7,313,326	85,025,346	2,092,483	153,516,933	3,394,273	161,313,079	3,494,982	161,074,535	3,436,114
Unbleached.....do.....			268,940,457	4,478,903	374,576,834	5,831,016	413,480,484	6,286,615	476,680,044	7,266,271
Mechanical.....do.....			260,279,169	2,057,877	319,347,992	2,542,725	527,002,249	4,198,760	431,863,879	3,516,537
<b>Total wood pulp.....do....</b>	<b>532,031,360</b>	<b>7,313,326</b>	<b>614,244,972</b>	<b>8,629,263</b>	<b>847,440,759</b>	<b>11,768,014</b>	<b>1,101,795,812</b>	<b>13,980,357</b>	<b>1,069,618,458</b>	<b>14,218,922</b>
<b>Total forest products.....</b>		<b>97,733,092</b>		<b>123,920,126</b>		<b>178,871,797</b>		<b>162,311,565</b>		<b>172,523,465</b>
<b>Fruit juices, n. e. s.:</b>										
Prune juice, or prune wine.gallons..	31,584	25,818	31,223	22,092	24,328	18,466	}	(²)	(²)	(²)
Other, including cherry juice, gallons.....do.....	40,467	26,677	31,703	20,734	38,392	27,042				
<b>Total fruit juices, n. e. s.,   gallons.....do.....</b>	<b>72,051</b>	<b>52,495</b>	<b>62,926</b>	<b>42,826</b>	<b>62,720</b>	<b>45,508</b>		(²)	(²)	(²)
<b>Fruits:</b>										
<b>Fresh or dried—</b>										
Bananas.....bunches..	37,003,388	11,391,211	36,973,584	11,012,100	38,156,659	11,642,693	44,699,222	14,375,075	44,520,539	14,368,330
Currants.....pounds..	38,652,656	1,592,018	32,482,111	1,185,106	33,326,030	1,190,020	33,439,565	1,486,263	33,151,396	1,561,350
Dates.....do.....	24,958,343	689,190	21,869,218	526,747	22,693,713	516,704	29,504,592	621,819	25,208,248	536,983
Figs.....do.....	18,836,574	867,523	15,235,513	691,981	17,362,197	775,319	23,459,728	1,059,340	18,765,408	934,763
Grapes.....cubic feet..	2,234,508	2,743,356	1,203,419	1,575,620	1,365,310	1,682,994	1,485,159	1,723,022	2,000,841	2,331,504
Lemons.....pounds..	178,490,003	4,388,530	135,183,550	2,623,399	160,214,785	3,136,933	134,968,924	2,985,561	145,639,396	3,368,863
Olives.....gallons..	3,121,788	1,358,897	2,969,329	1,349,023	4,555,075	1,659,801	3,044,947	1,567,546	5,076,857	2,303,277
Oranges.....pounds..	18,397,429	275,060	8,435,873	137,390	4,676,118	82,457	7,672,186	116,658	7,628,662	108,880
Pineapples.....do.....		( <sup>5</sup> )		( <sup>5</sup> )		1,317,462		979,721		1,110,341
Plums and prunes.....pounds..	335,089	49,322	296,123	41,696		( <sup>5</sup> )		( <sup>5</sup> )		( <sup>5</sup> )
Raisins.....do.....	9,132,353	554,633	5,794,320	327,644	5,042,683	296,047	2,479,220	237,422	3,255,861	295,466
Other.....do.....		2,250,813		1,912,949		920,362		971,572		1,693,516
<b>Total fresh or dried.....</b>		<b>26,160,553</b>		<b>21,383,655</b>		<b>23,220,792</b>		<b>26,123,999</b>		<b>28,613,273</b>
<b>Prepared or preserved.....</b>		<b>1,550,246</b>		<b>1,062,775</b>		<b>956,368</b>		<b>893,633</b>		<b>936,107</b>
<b>Total fruits.....do.....</b>		<b>27,710,799</b>		<b>22,446,430</b>		<b>24,177,160</b>		<b>27,017,632</b>		<b>29,549,380</b>
<b>Ginger, preserved or pickled...pounds..</b>	<b>409,331</b>	<b>27,189</b>	<b>523,360</b>	<b>34,665</b>	<b>527,721</b>	<b>27,585</b>	<b>350,117</b>	<b>22,036</b>	<b>468,329</b>	<b>30,139</b>

¹ Included in "All other," wood.  
² Not stated.

³ Included in "Other," cabinet woods, unsawed  
⁴ Included in "Other," lumber.

⁵ Included in "Other," fruits, fresh or dried.

TABLE 184.—Agricultural imports of the United States during the five years ending June 30, 1912—Continued.

Article imported.	1908		1909		1910		1911		1912	
	Quantity.	Value.	Quantity.	Value.	Quantity.	Value.	Quantity.	Value.	Quantity.	Value.
VEGETABLE MATTER—continued.										
Grain and grain products:										
Grain—										
Barley..... bushels..	199,741	\$143,407	2,644	\$1,440	.....	(1)	.....	(1)	.....	(1)
Corn.....do.....	20,312	15,536	258,065	189,465	.....	(1)	.....	(1)	53,425	\$47,936
Oats.....do.....	364,307	179,714	6,666,989	2,651,699	1,034,511	\$400,920	107,318	\$41,990	2,622,357	1,053,470
Rye.....do.....	17	16	51	51	.....	(1)	.....	(1)	.....	(1)
Wheat.....do.....	341,617	329,766	41,082	36,741	164,201	150,561	509,439	476,586	2,699,130	2,212,887
Total grain.....do.....	925,994	668,439	6,968,831	2,879,396	1,198,712	551,481	616,757	518,576	5,374,912	3,314,293
Grain products—										
Bread and biscuit.....		(1)		(1)		(1)		(1)		282,753
Macaroni, vermicelli, etc., pounds.....	97,233,708	4,009,995	85,114,003	3,676,786	113,772,801	4,926,812	114,779,116	4,864,318	108,231,028	4,738,937
Malt.....bushels.....	2,625	3,090	1,592	1,992	(2)	(2)	777	996	3,771	5,098
Meal and flour—										
Oatmeal.....pounds.....	344,003	19,876	444,801	24,612		(1)		(1)		(1)
Wheat flour.....barrels.....	39,593	179,295	92,413	446,500	144,759	681,944	141,582	625,287	158,777	665,346
Total meal and flour.....		199,171		471,112		681,944		625,287		665,346
Other.....		685,774		1,031,030		1,349,817		1,728,702		3,418,685
Total grain products.....		4,898,030		5,180,920		6,958,573		7,219,303		9,110,819
Total grain and grain products.....		5,566,469		8,060,316		7,510,054		7,737,879		12,425,112
Hay.....long tons.....	10,063	89,808	6,712	60,854	96,829	775,916	336,757	2,544,058	699,004	6,473,230
Hops.....pounds.....	8,493,265	1,989,261	7,386,574	1,337,099	3,200,560	1,499,354	8,557,531	2,706,600	2,991,125	2,231,348
Indigo.....do.....	6,078,073	1,058,354	8,249,972	1,400,286	7,538,689	1,195,942	6,908,751	1,152,518	7,658,067	1,153,142
Licorice root.....do.....	109,355,720	1,864,436	97,742,776	1,628,894	82,207,496	1,365,077	125,135,490	2,060,235	74,582,225	1,309,789
Liquors, alcoholic:										
Distilled spirits—										
Of domestic manufacture, re- turned.....proof galls..	148,298	160,439	134,015	148,776	119,646	124,162	(2)	(2)	(2)	(2)
Brandy.....do.....	592,382	1,523,842	764,244	1,961,170	716,259	1,899,021	409,242	1,018,382	509,286	1,316,031
Cordials, liqueurs, etc.....do.....	(3)	(2)	(2)	(2)	(3)	(3)	(3)	(3)	532,151	1,052,929

Gin.....do.....	}	3,216,228	4,876,325	3,889,066	5,566,879	1,240,662	1,015,035	1,045,815	994,050	824,694	915,422
Whisky.....do.....						1,060,300	2,167,064	1,293,692	2,668,749	1,373,010	2,833,917
Other.....do.....						1,245,308	1,907,941	925,601	1,395,748	411,595	344,929
Total distilled spirits..do....		3,956,908	6,560,606	4,787,325	7,676,825	4,382,175	7,113,223	3,674,350	6,076,929	3,650,736	6,463,228
Malt liquors—											
Bottled.....gallons..		1,960,333	1,829,917	1,801,043	1,695,747	1,727,541	1,605,919	1,954,092	1,790,492	1,651,564	1,571,336
Unbottled.....do.....		5,564,773	1,634,754	5,105,082	1,519,660	5,560,491	1,658,034	5,339,800	1,605,874	5,523,941	1,708,590
Total malt liquors.....do....		7,525,106	3,464,671	6,906,105	3,215,407	7,288,032	3,263,953	7,293,892	3,396,366	7,175,505	3,279,926
Wines—											
Champagne and other sparkling.....dozen quarts..		366,669	5,221,070	436,628	6,863,785	391,022	6,302,702	218,495	3,566,824	281,134	4,638,090
Still wines—											
Bottled.....do.....		628,428	2,516,461	650,861	2,574,596	822,266	3,177,140	596,529	2,326,763	577,244	2,414,621
Unbottled.....gallons..		5,443,782	3,008,996	5,747,056	2,838,232	7,100,666	3,527,918	4,812,787	2,638,039	3,864,070	2,488,740
Total still wines.....do....			5,525,457		5,412,828		6,705,058		4,964,802		4,903,361
Total wines.....do.....			10,746,527		12,276,613		13,007,760		8,531,626		9,591,451
Total alcoholic liquors.....do....			20,771,804		23,168,845		23,384,936		18,004,921		19,334,605
Malt, barley. (See Grain and grain products.)											
Malt extract, fluid and solid.....do.....			21,227		4,450		(2)		16,295		8,639
Malt liquors. (See Liquors, alcoholic.)											
Nursery stock:											
Plants, trees, shrubs, and vines—											
Fruit plants, tropical and semi-tropical, for propagation, etc..			1,912		4,001		11,914		18,962		24,825
Bulbs, bulbous roots or corms, cultivated for their flowers or foliage.....do.....			2,003,973		954,399		1,242,773		1,642,274		1,723,354
Other.....do.....					988,507		1,106,977		1,094,637		1,251,365
Total nursery stock.....do....			2,005,885		1,946,907		2,361,664		2,755,873		2,999,544

<sup>1</sup>Included in "Other," grain products.<sup>2</sup>Not stated.<sup>3</sup>Included in "Other," distilled spirits.

TABLE 184.—Agricultural imports of the United States during the five years ending June 30, 1912—Continued.

Article imported.	1908		1909		1910		1911		1912	
	Quantity.	Value.	Quantity.	Value.	Quantity.	Value.	Quantity.	Value.	Quantity.	Value.
<b>VEGETABLE MATTER—continued.</b>										
<b>Nuts:</b>										
Almonds.....pounds..	17, 144, 968	\$2, 410, 648	11, 029, 421	\$1, 852, 523	18, 556, 356	\$3, 153, 645	15, 522, 712	\$2, 896, 573	17, 231, 458	\$3, 253, 495
Coconuts, unshelled.....		1, 439, 770		1, 252, 594		1, 295, 854		1, 704, 105		1, 949, 406
Coconut meat, broken, or copra— Not shredded, desiccated, or prepared.....pounds..	14, 121, 570	481, 232	23, 842, 522	666, 820	21, 306, 219	762, 560	37, 817, 051	1, 536, 718	64, 580, 670	2, 810, 171
Shredded, desiccated, or pre- pared.....pounds.....		( <sup>1</sup> )		( <sup>1</sup> )		( <sup>1</sup> )		( <sup>1</sup> )	5, 331, 826	404, 969
Cream and Brazil.....bushels..	310, 420	754, 155	407, 719	761, 219	461, 496	1, 251, 738	283, 902	804, 064	21, 539, 508	1, 092, 671
Filberts.....pounds.....		( <sup>1</sup> )		( <sup>1</sup> )	11, 593, 600	792, 466	13, 957, 940	1, 064, 772	11, 198, 991	813, 642
Palm, and palm nut kernels.....		2, 277		4, 079		( <sup>1</sup> )		( <sup>1</sup> )		( <sup>1</sup> )
Peanuts—										
Shelled.....pounds.....		( <sup>1</sup> )		( <sup>1</sup> )	29, 276, 235	1, 234, 088	18, 834, 441	765, 033	12, 930, 563	473, 065
Unshelled.....do.....									2, 627, 475	102, 217
Walnuts.....do.....	28, 887, 110	2, 765, 486	26, 157, 703	2, 409, 644	33, 641, 466	3, 538, 264	33, 619, 434	4, 471, 227	37, 213, 674	4, 069, 515
Other.....do.....		1, 790, 375		1, 717, 374		1, 218, 127		1, 255, 921		888, 862
Total nuts.....		9, 643, 943		8, 664, 253		13, 246, 742		14, 498, 413		15, 828, 003
Oil cake.....pounds..	2, 848, 291	27, 513	1, 742, 727	18, 456	5, 208, 376	59, 698	12, 405, 660	139, 332	16, 960, 968	204, 746
<b>Oils, vegetable:</b>										
Fixed or expressed—										
Cocoa butter or butterine, pounds.....		( <sup>2</sup> )		( <sup>2</sup> )	3, 369, 528	679, 871	4, 278, 896	1, 090, 818	6, 074, 741	1, 615, 377
Coconut oil.....pounds..	45, 422, 575	3, 267, 585	52, 490, 558	3, 079, 682	48, 345, 672	3, 341, 409	51, 118, 317	4, 144, 444	46, 370, 732	3, 851, 279
Cottonseed.....do.....		( <sup>2</sup> )		( <sup>2</sup> )		( <sup>2</sup> )		( <sup>2</sup> )	1, 513, 051	78, 077
Flaxseed or linseed.....gallons..									737, 256	486, 060
Hemp and rape seed—										
Hempseed.....do.....		( <sup>2</sup> )		( <sup>2</sup> )	1, 082, 775	464, 742	1, 362, 985	599, 047	126	159
Rapeseed.....do.....									1, 182, 768	588, 138
Nut oil, or oil of nuts, n. e. s.—										
Chinese nut.....gallons..					5, 759, 683	2, 440, 010	7, 042, 057	2, 917, 067	4, 767, 596	2, 383, 503
Peanut nut.....do.....	1, 869, 120	882, 983	2, 912, 965	1, 158, 132					895, 587	582, 740
Olive, for mechanical purposes, gallons.....	1, 565, 253	703, 829	369, 979	183, 983	842, 926	477, 679	578, 477	378, 819	636, 013	389, 539
Olive, salad.....gallons..	3, 799, 112	3, 876, 901	4, 129, 454	5, 069, 655	3, 702, 210	4, 869, 114	4, 405, 827	6, 014, 191	4, 836, 515	6, 170, 882
Palm oil.....pounds..	30, 614, 875	1, 849, 611	58, 976, 379	3, 185, 038	92, 771, 868	5, 590, 535	57, 100, 406	4, 102, 916	47, 159, 238	3, 090, 090

Palm kernel.....do.....								25,932,855	2,073,721
Soya bean.....do.....		(?)		(?)		(?)		28,021,282	1,577,181
Other.....do.....		1,788,150		1,945,080		2,952,273		7,885,041	355,767
Total fixed or expressed.....		12,369,059		14,621,570		20,815,633		27,132,343	23,242,463
Volatile or essential—									
Lemon.....pounds..		3,645,441		2,932,512	415,501	309,383	430,458	322,727	451,588
Other.....do.....					1,857,944			2,260,679	3,140,692
Total volatile or essential.....		3,645,441		2,932,512		2,167,327		2,583,406	3,592,280
Total vegetable oils.....		16,014,500		17,554,082		22,982,960		29,715,749	26,834,743
Opium, crude.....pounds..	285,845	1,151,207	517,388	1,951,518	449,239	1,622,475	629,842	2,208,445	399,837
Rice, rice meal, etc.:									
Rice—									
Cleaned.....do.....									
Uncleaned, including paddy, pounds.....	87,619,202	2,543,417	88,780,442	2,361,310	82,662,162	2,112,032	76,657,974	2,126,822	848,469
Rice flour, rice meal, and broken rice.....pounds..	125,164,190	2,255,136	134,119,980	2,336,723	142,738,383	2,249,205	132,116,821	1,998,056	1,618,379
Total rice, etc.....do.....	212,783,392	4,798,553	222,900,422	4,698,033	225,400,545	4,361,237	208,774,795	4,124,878	1,968,177
Sago, tapioca, etc.....		1,574,835		1,396,090		990,525		1,590,971	4,435,025
Seeds:									
Castor beans or seeds.....bushels		(*)		(*)	726,002	831,056	745,035	947,782	1,080,535
Clover.....do.....	20,659,396	2,323,699	13,786,451	1,202,758	13,069,830	1,472,588	25,857,826	3,046,276	6,099,136
Flaxseed, or linseed.....do.....	57,419	71,625	593,668	831,871	5,002,496	8,548,837	10,499,227	21,379,180	12,995,250
Grass seed, n. e. s.....pounds		(*)		(*)		(*)		(*)	1,400,077
Sugar beet.....do.....		(*)		(*)	10,308,666	668,312	10,988,617	724,592	1,103,357
Other.....do.....		3,976,146		3,923,390		3,172,983		3,660,125	2,962,817
Total seeds.....do.....		6,371,470		5,958,019		14,693,776		29,757,955	25,641,172
Spices:									
Unground—									
Cassia, or cassia vera.....pounds	(4)	(4)	(4)	(4)	(4)	(4)	(4)	(4)	6,795,943
Ginger root, not preserved.....do.....	(4)	(4)	(4)	(4)	(4)	(4)	(4)	(4)	5,979,314
Nutmegs.....do.....	2,042,396	236,787	2,645,079	219,286					368,175
Pepper, black or white.....do.....	20,335,693	1,532,901	37,094,824	2,115,413	15,488,848	1,102,104	22,065,074	1,622,311	2,599,479
Other.....do.....	14,332,230	1,194,798	30,497,704	2,114,920	21,862,111	1,660,843	28,140,552	2,383,497	1,464,239
Total unground.....do.....	36,710,319	2,964,486	70,237,607	4,449,619	37,350,959	2,762,947	50,205,626	4,005,808	53,229,355
Ground.....do.....	5,414,493	627,051	7,964,336	898,987	6,442,199	720,512	8,017,286	940,392	9,887,193
Total spices.....do.....	42,124,812	3,591,537	78,201,943	5,348,606	43,793,158	3,483,459	58,222,912	4,946,200	63,116,548

\*Included in "Other," nuts.

\*Included in "Other," fixed or expressed.

\*Included in "Other" seeds.

\*Included in "Other" spices, unground.



TABLE 184.—Agricultural imports of the United States during the five years ending June 30, 1912—Continued.

Article Imported.	1908		1909		1910		1911		1912	
	Quantity.	Value.	Quantity.	Value.	Quantity.	Value.	Quantity.	Value.	Quantity.	Value.
<b>VEGETABLE MATTER—continued.</b>										
Spirits, distilled. (See Liquors, alcoholic.)										
Starch.....pounds..	5,284,050	\$138,166	17,301,351	\$424,089	10,861,310	\$296,030	7,938,730	\$222,470	15,841,437	\$478,465
Straw and grass.....long tons..	1,462	7,659	2,054	12,098	6,762	32,367	4,287	18,659	10,172	56,702
Sugar and molasses:										
Molasses.....gallons..	18,882,756	721,867	22,092,696	937,791	31,292,165	1,367,362	23,838,190	995,006	28,828,213	1,197,878
Sugar—										
Raw—										
Beet.....pounds..	221,036,900	5,401,378	98,625,908	2,521,798	1,148	43	24,669,287	593,037	6,504,260	239,484
Cane.....do....	3,144,022,423	74,509,970	4,084,921,078	93,768,598	4,088,437,524	103,075,846	3,909,106,213	95,889,959	4,092,129,718	114,958,470
Total raw.....do....	3,365,059,323	79,911,348	4,183,546,986	96,290,396	4,088,438,672	106,075,889	3,933,775,500	96,482,996	4,098,633,978	115,197,954
Refined.....do....	6,937,789	346,799	5,874,032	264,602	6,107,264	273,116	4,202,765	208,100	5,984,415	317,125
Total sugar.....do....	3,371,997,112	80,258,147	4,189,421,018	96,554,998	4,094,545,936	106,349,005	3,937,978,265	96,691,096	4,104,618,393	115,515,079
Total sugar and molasses.....		80,980,014		97,492,789		107,716,367		97,686,102		116,712,957
Sugar-beet pulp.....pounds..	( <sup>1</sup> )	( <sup>1</sup> )	1,556,467	12,871	3,405,500	27,228	2,685,440	22,156		
Tea.....do....	94,149,564	16,309,870	114,916,520	18,562,676	85,626,370	13,671,946	102,653,942	17,613,569	101,406,816	13,207,141
Tea, waste, etc., for manufacturing, pounds	( <sup>1</sup> )	( <sup>1</sup> )	1,920,918	59,317	3,229,221	96,122	3,736,789	94,302	5,994,547	161,532
Teazels.....do....		10,509		8,412		( <sup>1</sup> )		4,401		18,998
Tobacco:										
Leaf—										
Wrapper.....pounds..	5,943,714	6,312,023	5,648,178	5,342,634	6,647,948	6,483,555	5,956,776	6,420,298	6,474,881	8,104,907
Filler and other leaf.....do....	26,112,329	16,558,305	36,087,920	20,058,285	40,205,441	21,270,003	39,976,129	21,437,003	46,536,954	23,814,407
Stems.....do....	2,949,088	14,203	1,387,098	4,854	( <sup>1</sup> )	( <sup>1</sup> )	2,270,383	8,264	1,728,545	6,270
Total tobacco.....do....	35,005,131	22,884,531	43,123,196	25,405,773	46,853,389	27,753,558	48,203,288	27,865,565	54,740,380	31,925,584
Vanilla beans.....do....	571,977	1,170,135	1,121,485	1,495,469	797,409	1,203,773	1,140,650	1,953,372	841,628	2,025,153

<b>Vegetables:</b>										
Fresh or dried—										
Beans <sup>1</sup> ..... bushels..	1,657,401	2,406,935	3,355,405	4,926,199	1,015,157	1,621,207	1,037,371	1,733,697	1,004,930	1,857,220
Onions..... do.....	1,275,333	866,663	574,530	412,127	1,024,226	769,539	1,514,967	1,078,201	1,436,037	1,234,316
Peas, dried..... do.....	( <sup>2</sup> )	( <sup>2</sup> )	( <sup>2</sup> )	( <sup>2</sup> )	( <sup>2</sup> )	( <sup>2</sup> )	( <sup>2</sup> )	( <sup>2</sup> )	806,762	1,515,516
Potatoes..... do.....	403,952	283,032	8,383,966	3,677,034	353,208	306,815	218,984	235,847	13,734,695	7,168,627
Other..... do.....		1,138,429		1,104,036		1,857,846		2,554,889		1,726,145
<b>Total fresh or dried.....</b>		<b>4,695,059</b>		<b>10,119,396</b>		<b>4,555,407</b>		<b>5,602,634</b>		<b>13,501,824</b>
Prepared or preserved—										
Mushrooms..... pounds.....		( <sup>3</sup> )		( <sup>3</sup> )	17,038,127	940,382	6,656,957	860,884	7,406,927	1,013,082
Pickles and sauces.....		816,245		796,842		935,609		886,304		1,086,851
Other.....		2,777,764		2,083,559		1,841,973		1,944,033		2,943,116
<b>Total prepared or preserved.....</b>		<b>3,594,009</b>		<b>2,880,401</b>		<b>3,717,964</b>		<b>3,691,221</b>		<b>5,043,049</b>
<b>Total vegetables.....</b>		<b>8,289,068</b>		<b>12,999,797</b>		<b>8,273,371</b>		<b>9,293,855</b>		<b>18,544,873</b>
Vinegar..... gallons.....	204,213	56,671	280,033	71,867	301,030	78,577	302,898	75,816	360,524	81,899
Wafers, unmedicated.....		28,016		25,316		36,922		32,173		29,593
Wax, vegetable..... pounds.....	( <sup>1</sup> )	( <sup>1</sup> )	( <sup>1</sup> )	( <sup>1</sup> )	5,241,087	823,053	4,281,596	838,405	4,665,828	1,080,200
Wines. ( <i>See Liquors, alcoholic.</i> )										
<b>Total vegetable matter, including forest products.....</b>		<b>467,033,735</b>		<b>527,277,381</b>		<b>595,357,986</b>		<b>633,595,218</b>		<b>711,943,405</b>
<b>Total vegetable matter, excluding forest products.....</b>		<b>369,300,643</b>		<b>403,357,255</b>		<b>416,486,189</b>		<b>471,283,653</b>		<b>539,419,940</b>
<b>Total agricultural imports, including forest products.....</b>		<b>637,423,213</b>		<b>762,532,818</b>		<b>866,380,912</b>		<b>842,516,497</b>		<b>955,980,936</b>
<b>Total agricultural imports, excluding forest products.....</b>		<b>539,690,121</b>		<b>638,612,692</b>		<b>687,509,115</b>		<b>680,204,932</b>		<b>783,457,471</b>

<sup>1</sup> Not stated.<sup>2</sup> Prior to July 1, 1909, including "Dried peas."<sup>3</sup> Included in "Beans."<sup>4</sup> Included in "Other" vegetables, fresh or dried.<sup>5</sup> Included in "Other" vegetables, prepared or preserved.

TABLE 185.—Agricultural exports (domestic) of the United States during the five years ending June 30, 1912.

Article exported.	1908		1909		1910		1911		1912	
	Quantity.	Value.	Quantity.	Value.	Quantity.	Value.	Quantity.	Value.	Quantity.	Value.
<b>ANIMAL MATTER.</b>										
<b>Animals, live:</b>										
Cattle.....number..	349,210	\$29,339,134	207,542	\$18,046,976	139,430	\$12,200,154	150,100	\$13,163,920	105,506	\$8,870,075
Fowls.....		151,925		115,946		137,619		(1)		(1)
Horses.....number..	19,000	2,612,587	21,616	3,386,617	28,910	4,081,157	25,145	3,845,253	34,828	4,764,815
Mules.....do.....	6,609	990,667	3,432	472,017	4,512	614,094	6,585	1,070,051	4,901	732,095
Sheep.....do.....	101,000	589,285	67,656	365,155	44,517	209,000	121,491	636,272	157,263	626,985
Swine.....do.....	30,818	307,202	18,655	144,605	4,410	46,955	8,551	74,032	19,038	159,370
Other.....do.....		110,489		114,122		158,756		* 259,125		* 294,647
<b>Total live animals.....</b>		<b>34,101,289</b>		<b>22,645,438</b>		<b>17,447,735</b>		<b>19,048,653</b>		<b>15,447,987</b>
Beeswax.....pounds..	90,506	28,659	77,547	23,293	89,890	27,740	101,735	31,404	109,478	32,556
<b>Dairy products:</b>										
Butter.....do.....	6,463,061	1,407,962	5,981,265	1,268,210	3,140,545	785,771	4,877,797	1,059,432	6,092,235	1,468,432
Cheese.....do.....	8,439,031	1,092,053	6,822,842	857,091	2,846,709	441,017	10,366,605	1,288,279	6,337,559	898,035
Milk—										
Condensed.....do.....	(*)	2,455,186	(*)	1,375,104	13,311,318	1,023,633	12,180,445	936,105	20,642,738	1,651,879
Other, including cream.....									244,913	244,913
<b>Total dairy products.....pounds.</b>	<b>(*)</b>	<b>4,955,201</b>	<b>(*)</b>	<b>3,500,405</b>	<b>19,298,572</b>	<b>2,250,421</b>	<b>27,424,847</b>	<b>3,283,816</b>		<b>4,263,259</b>
Eggs.....dozens.....	7,590,977	1,540,014	5,207,151	1,199,522	5,325,936	1,280,486	8,558,712	1,787,019	15,405,609	3,395,952
Egg yolks.....		9,024		23,938		3,585		5,353		29,541
Feathers.....		389,586		400,045		312,784		250,906		369,693
<b>Fibers, animal:</b>										
Silk waste.....pounds..	198,736	49,581	300,553	77,944	266,207	64,528	119,801	30,863	71,132	16,080
Wool.....do.....	182,458	42,104	28,376	4,668	47,520	10,077	(*)	(*)	(*)	(*)
<b>Total animal fibers.....do.....</b>	<b>381,194</b>	<b>91,985</b>	<b>328,929</b>	<b>82,612</b>	<b>313,727</b>	<b>74,605</b>	<b>119,801</b>	<b>30,863</b>	<b>71,132</b>	<b>16,080</b>
Glue.....do.....	2,917,173	289,441	2,340,426	244,751	2,488,205	261,756	2,307,966	242,755	3,059,952	314,909
Honey.....do.....		78,102		85,578		159,401		81,649		212,652
<b>Packing-house products:</b>										
Beef—										
Canned.....pounds..	23,376,447	2,467,875	14,895,527	1,645,822	14,804,596	1,678,452	10,824,504	1,254,979	11,026,431	1,203,404

Cured—											
Salted or pickled.....do.....	46,958,367	3,213,480	44,494,210	3,438,048	36,554,266	2,744,886	} 40,283,749	3,501,179	38,087,907	2,832,109	
Other.....do.....	937,720	106,470	294,853	34,319	317,047	38,815					
Total cured.....do.....	47,896,087	3,319,950	44,789,063	3,472,367	36,871,313	2,783,701	40,283,749	3,501,179	38,087,907	2,832,109	
Fresh.....do.....	201,154,105	20,339,377	122,952,671	12,698,594	75,729,666	7,733,751	42,510,731	4,478,401	15,264,320	1,596,319	
Oils—Oleo oil 4.....do.....	212,541,157	19,278,476	179,985,246	19,126,741	126,091,675	14,305,080	138,696,906	13,658,762	126,467,124	13,434,018	
Oleomargarine.....do.....	2,938,175	299,746	2,889,058	293,635	3,418,632	349,972	3,794,939	408,459	3,627,425	372,567	
Tallow.....do.....	91,397,507	5,399,219	53,332,767	3,000,366	29,379,992	1,779,615	29,813,154	1,933,681	39,451,419	2,388,046	
Total beef.....do.....	579,303,478	51,104,643	418,844,332	40,237,525	286,295,874	28,630,571	265,923,983	26,235,461	233,924,626	21,926,463	
Bones, hoofs, horns, and horn tips, strips and waste.....do.....		245,628		232,628		150,371		152,167		162,009	
Bristles.....do.....		410		(*)		(*)		(*)		(*)	
Grease, grease scraps, and all soap stock.....do.....		5,762,709		4,814,901		4,612,426		5,177,581		4,486,329	
Hair.....do.....		1,165,475		988,749		1,142,845		1,274,345		1,426,111	
Hides and skins, other than furs—											
Calfskins.....pounds.....	} 14,650,454	1,536,225	12,858,975	1,271,190	14,635,075	1,738,216	44,594,235	4,802,637	548,242	99,592	
Cattle hides.....do.....									17,445,209	2,289,648	
Other.....do.....									7,253,349	769,255	
Total.....do.....	14,650,454	1,536,225	12,858,975	1,271,190	14,635,075	1,738,216	44,594,235	4,802,637	25,246,800	3,158,495	
Lard compounds.....do.....	75,183,210	6,035,418	75,183,196	6,115,307	74,556,608	6,887,738	73,754,400	7,070,967	62,522,888	5,183,689	
Meat, canned, n. e. s.....do.....		1,265,283		1,060,222		1,030,031		1,180,123		1,296,152	
Mutton.....pounds.....	1,185,040	117,688	1,498,674	141,654	1,989,472	213,477	2,180,259	219,517	3,595,543	349,875	
Oils, animal, n. e. s.....gallons.....	621,300	341,304	614,383	343,838	535,875	401,460	1,019,478	681,096	1,019,412	754,342	
Pork—											
Canned.....pounds.....	4,957,022	532,442	5,759,930	620,193	4,062,022	459,843	4,010,862	483,959	5,839,902	681,127	
Cured—											
Bacon.....do.....	241,189,929	25,481,246	244,578,674	25,920,490	152,163,107	18,381,050	156,675,310	21,211,605	208,574,208	24,907,197	
Hams and shoulders.....do.....	221,769,634	25,167,059	212,170,224	23,526,307	146,885,385	17,837,375	157,709,316	20,708,882	204,044,491	24,983,376	
Salted or pickled.....do.....	149,605,937	13,332,654	52,354,980	4,599,431	40,031,599	4,421,844	45,729,471	4,944,448	56,321,469	5,348,594	
Total cured.....do.....	612,465,500	63,980,959	509,103,878	54,046,228	339,080,091	40,640,269	360,114,097	46,864,985	468,940,168	55,239,16	
Fresh.....do.....	16,374,468	1,551,450	9,555,315	938,025	1,040,278	126,888	1,355,378	159,654	2,597,880	297,198	
Lard.....do.....	603,413,770	54,789,748	528,722,933	52,712,509	362,927,671	43,301,166	476,107,857	52,509,217	532,255,865	52,090,441	
Lard, neutral.....do.....	(*)	(*)	(*)	(*)	(*)	(*)	37,866,812	4,134,294	62,317,909	6,655,009	
Oils—Lard oil.....gallons.....	259,062	169,625	234,626	167,644	151,142	131,241	120,094	90,724	207,337	147,766	
Total pork.....do.....		121,024,224		108,484,659		84,659,397		104,242,783		115,110,708	

1 Included in "Other" live animals.  
\* Including "Fowls."

\* Not stated.  
4 Prior to July 1, 1910, including "Lard, neutral."

\* Included in "Oleo oil."

TABLE 185.—Agricultural exports (domestic) of the United States during the five years ending June 30, 1912—Continued.

Article exported.	1908		1909		1910		1911		1912	
	Quantity.	Value.	Quantity.	Value.	Quantity.	Value.	Quantity.	Value.	Quantity.	Value.
<b>ANIMAL MATTER—continued.</b>										
<b>Packing-house products—Continued.</b>										
Sausage and sausage meat. pounds..	8,367,495	\$969,472	8,538,058	\$997,655	5,072,255	\$627,669	4,716,610	\$601,596	8,036,591	\$1,045,834
Sausage casings.....do.....	(1)	3,959,384	(1)	3,520,191	35,418,957	4,503,339	40,013,760	5,466,661	36,496,326	5,034,714
All other.....do.....		2,659,228		1,783,331		1,361,833		1,197,732		1,497,993
<b>Total packing-house products</b> .....		196,187,091		169,991,850		135,959,373		157,302,666		161,434,714
Poultry and game.....do.....		881,792		848,644		599,548		981,805		697,955
Silk waste. (See Fibers, animal.)										
Wool. (See Fibers, animal.)										
<b>Total animal matter</b> .....do.....		238,552,154		199,046,076		158,357,434		183,046,889		186,215,298
<b>VEGETABLE MATTER.</b>										
<b>Breadstuffs. (See Grain and grain products.)</b>										
Broom corn.....do.....	(1)	266,696	(1)	304,522	(1)	424,484	(1)	363,644	3,320	461,110
Cider.....gallons.....	172,617	26,401	87,630	14,121	5,784	1,965	22,708	8,791	63,882	10,460
Cocoa, ground or prepared, and chocolate.....do.....		403,509		471,458		471,358		498,694		514,266
<b>Coffee:</b>										
Green or raw.....pounds..	35,356,109	4,314,020	28,630,278	3,729,840	45,514,438	5,703,786	34,853,601	5,107,949	40,779,693	6,864,668
Roasted or prepared.....do.....	4,301,029	474,451	980,100	155,776	1,210,886	196,348	1,484,290	272,532	1,408,767	306,090
<b>Total coffee</b> .....do.....	39,657,138	4,788,471	29,610,378	3,885,616	46,725,324	5,900,134	36,337,891	5,380,481	42,248,460	7,170,758
<b>Cotton:</b>										
Sea Island.....do.....	33,042 } 12,699,567 } 7,401,538 }	3,351,132	25,939 } 9,740,806 } 8,551,789 }	2,035,120	30,201 } 11,460,277 } 6,233,092 }	3,276,441	21,622 } 8,214,847 } 7,807,414 }	2,345,567	26,872 } 10,693,038 } 10,648,573 }	2,460,130
Upland.....do.....	(bales....) (pounds..) 3,804,299,126	434,437,070	(bales....) (pounds..) 4,438,244,396	415,355,545	(bales....) (pounds..) 3,195,247,949	447,170,802	(bales....) (pounds..) 4,025,726,068	582,973,302	(bales....) (pounds..) 5,524,432,391	563,389,141
<b>Total cotton</b> .....do.....	3,816,998,693	437,788,202	4,447,985,202	417,390,665	3,206,708,226	450,447,243	4,033,940,915	585,318,869	5,535,125,429	565,849,271
Flavoring extracts and fruit juices.....do.....		52,395		64,418		84,856		136,354		173,402
Flowers, cut.....do.....		1,784		4,433		10,585		24,676		38,238

Forest products:										
Bark, and extract of, for tanning—										
Bark.....pounds.....	3,987,330	57,515	3,845,690	56,572	1,210,305	18,291	1,654,439	19,935	4,188,945	57,319
Bark, extracts of.....		241,608		260,965		388,448		330,600		404,024
Total bark, etc.....		299,123		317,537		406,739		356,535		461,343
Charcoal.....		4,271		13,360		25,310		27,317		45,726
Moss.....		33,742		39,284		41,243		51,445		34,524
Naval stores—										
Rosin.....barrels.....	2,712,732	11,395,126	2,170,177	8,004,838	2,144,318	9,753,488	2,189,607	14,067,335	2,474,460	16,462,850
Tar.....do.....	14,691	53,983	11,072	46,442						
Turpentine and pitch.....do.....	13,448	46,339	10,034	31,809	40,037	148,238	40,380	187,183	50,107	223,002
Turpentine, spirits of.....gallons.....	19,532,583	10,146,151	17,502,028	7,018,058	15,587,737	8,780,236	14,817,751	10,768,202	19,599,241	10,069,135
Total naval stores.....		21,641,599		15,101,147		18,681,962		25,022,720		26,754,987
Wood—										
Logs <sup>2</sup> —										
Hickory.....M feet.....									7,974	271,722
Oak.....do.....		4,337,766		2,846,863		3,432,635		4,278,249	5,039	200,072
Walnut.....do.....									9,816	612,067
Other.....do.....									130,958	2,574,312
Total.....do.....		4,337,766		2,846,863		3,432,635		4,278,249	159,787	3,658,173
Lumber—										
Boards, deals, and planks—										
Fir.....M feet.....									629,220	7,640,038
Gum.....do.....									59,415	1,645,031
Oak.....do.....									222,266	9,529,413
Pine—										
Pitch pine.....do.....									779,375	15,852,231
Short-leaf pine, M feet.....	1,548,130	35,607,508	1,357,822	29,056,579	1,684,489	36,774,219	2,031,608	43,756,177	42,005	824,366
Other pine, M feet.....									270,918	6,580,689
Poplar.....do.....									23,105	985,291
Spruce.....do.....									17,424	510,047
Other.....do.....									262,952	7,493,538
Total.....do.....	1,548,130	35,607,508	1,357,822	29,056,579	1,684,489	36,774,219	2,031,608	43,756,177	2,306,680	51,060,644
Joists and scantling.....do.....	27,332	581,718	22,122	378,914	26,272	507,853	29,357	520,358	34,229	577,075
Shingles.....M.....	20,483	75,535	14,104	61,784	17,292	53,371	32,308	94,339	94,732	222,243

<sup>1</sup> Not stated.

<sup>2</sup> Prior to July 1, 1908, including firewood and other unmanufactured wood.

TABLE 185.—Agricultural exports (domestic) of the United States during the five years ending June 30, 1912—Continued.

Article exported.	1908		1909		1910		1911		1912	
	Quantity.	Value.	Quantity.	Value.	Quantity.	Value.	Quantity.	Value.	Quantity.	Value.
<b>VEGETABLE MATTER—continued.</b>										
<b>Forest products—Continued.</b>										
Wood—Continued.										
Lumber—Continued.										
Shooks—										
Box..... number..	(1)	\$958,127	(1)	\$957,682	(1)	\$1,121,613	(1)	\$1,109,646	10,225,688	\$1,070,286
Other..... do.....	900,812	1,716,190	977,376	1,962,199	928,197	1,654,611	1,019,411	1,662,032	1,161,591	1,888,467
Total shooks... do....	(1)	2,674,317	(1)	2,919,881	(1)	2,776,224	(1)	2,771,678	11,387,279	2,958,753
Staves and heading—										
Heading.....		176,430		154,766		223,038		388,369		318,092
Staves..... number..	61,696,949	6,016,690	52,583,016	5,524,199	49,783,771	4,673,085	65,725,595	5,666,854	64,162,599	5,748,394
Total staves and heading.....		6,193,120		5,678,965		4,896,123		6,055,223		6,066,486
Other.....		5,216,854		5,461,866		5,355,245		6,328,902		4,014,669
Total lumber.....		50,349,052		43,557,989		50,363,035		59,526,677		64,899,870
Timber—										
Hewn..... M feet..	58,602	1,316,465	35,406	839,011	38,942	825,192	32,086	770,123	31,067	644,129
Sawed—										
Pitch pine..... do....	463,440	11,040,677	383,309	8,414,519	451,721	9,852,027	499,547	11,476,732	287,652	5,612,768
Other..... do....									119,302	4,679,924
Total timber... do....	522,042	12,357,142	418,715	9,253,530	490,663	10,677,219	531,633	12,246,855	438,021	10,936,821
All other, including firewood..		(2)		479,996		460,210		275,870		256,249
Total wood.....		67,043,960		56,138,378		64,933,099		76,327,651		79,751,113
Wood alcohol..... proof galls..	1,958,630	819,753	1,100,495	383,788	1,328,601	581,820	1,962,336	881,991	1,565,368	685,565
Wood pulp..... pounds..	23,845,732	519,625	20,650,756	448,960	17,297,389	360,057	18,067,409	371,233	19,888,961	388,996
Total forest products.....		90,362,073		72,442,454		85,080,230		103,038,892		108,122,254

<b>Fruits:</b>										
<b>Fresh or dried—</b>										
Apples, dried..... pounds..	24,237,873	1,946,810	33,474,634	2,339,936	25,076,618	2,056,692	21,804,086	1,944,209	53,664,639	4,545,971
Apples, fresh..... barrels..	1,049,545	3,660,854	896,279	2,782,007	922,078	3,175,433	1,721,106	5,777,458	1,456,381	5,409,946
Apricots, dried..... pounds..	1,224,602	229,467	16,597,871	1,512,417	12,028,834	1,218,423	19,329,358	2,065,437	13,413,430	1,885,855
Oranges..... boxes..	654,251	1,577,661	866,753	2,181,724	932,118	2,213,905	1,179,273	2,983,322	1,197,363	3,022,859
Peaches, dried..... pounds..	1,148,598	144,318	2,403,430	151,334	2,617,069	151,520	7,125,014	499,530	4,425,803	422,766
Pears, fresh.....	288,918		546,198		302,958		578,067		784,627	
Prunes..... pounds..	28,148,450	1,642,114	22,602,288	1,078,210	89,014,880	4,016,554	51,030,711	3,271,971	74,328,074	4,969,053
Raisins..... do.....	5,684,541	427,583	7,890,161	455,657	8,526,114	417,403	18,659,992	1,069,300	19,949,046	1,351,986
Other.....	2,360,360		2,104,624		2,119,210		2,792,251		3,812,804	
<b>Total fresh or dried.....</b>		<b>12,278,085</b>		<b>13,102,107</b>		<b>15,672,098</b>		<b>21,001,575</b>		<b>26,205,867</b>
<b>Preserved—</b>										
Canned.....		1,549,826		2,899,374		2,656,019		2,686,445		4,012,463
Other.....		137,929		77,746		176,474		205,643		136,870
<b>Total preserved.....</b>		<b>1,687,755</b>		<b>2,977,120</b>		<b>2,832,493</b>		<b>2,892,088</b>		<b>4,149,333</b>
<b>Total fruits.....</b>		<b>13,965,840</b>		<b>16,079,227</b>		<b>18,504,591</b>		<b>23,893,663</b>		<b>30,354,700</b>
<b>Ginseng..... pounds..</b>	154,180	1,111,994	186,257	1,270,179	192,406	1,439,434	153,999	1,088,202	155,808	1,119,301
<b>Glucose and grape sugar:</b>										
Glucose..... do.....	98,608,192	1,898,652	92,652,409	1,938,406	112,730,639	2,623,131	137,461,782	2,596,220	126,395,045	2,911,736
Grape sugar..... do.....	81,078,642	641,988	19,572,095	407,683	37,089,449	792,089	44,501,264	799,163	44,761,214	1,005,161
<b>Grain and grain products:</b>										
<b>Grain—</b>										
Barley..... bushels..	4,349,078	3,205,528	6,580,393	4,672,166	4,311,566	3,052,527	9,399,346	5,381,360	1,585,242	1,267,999
Buckwheat..... do.....	116,127	94,638	186,702	137,413	158,160	103,138	223	186	180	147
Corn..... do.....	52,445,800	33,942,197	35,853,412	25,194,466	36,802,374	25,427,993	63,761,458	35,961,479	40,038,795	28,957,450
Oats..... do.....	1,158,622	624,569	1,510,320	804,759	1,685,474	794,367	2,044,912	832,718	2,171,503	1,135,635
Rye..... do.....	2,419,958	2,184,335	1,272,559	1,049,809	219,756	168,666	2,623	2,503	5,548	4,844
Wheat..... do.....	100,871,057	99,736,767	66,923,244	68,064,447	46,679,876	47,806,598	23,729,302	22,040,273	30,160,212	28,477,584
<b>Total grain..... do.....</b>	<b>160,860,642</b>	<b>139,788,034</b>	<b>112,826,630</b>	<b>99,953,060</b>	<b>89,857,206</b>	<b>77,353,289</b>	<b>98,937,864</b>	<b>64,218,519</b>	<b>73,961,480</b>	<b>59,843,659</b>
<b>Grain products—</b>										
Bran, middlings, and mill feed, long tons.....	116,917	3,004,174	45,737	1,222,406	53,548	1,521,622	67,687	1,895,555	144,504	4,226,173
<b>Breadstuffs preparations—</b>										
Bread and biscuit, pounds..	13,052,074	766,170	12,606,614	710,687	13,064,688	767,151	14,022,092	800,068	12,973,048	727,280
Other.....		1,885,915		1,858,646		2,040,314		2,362,559		2,063,876
<b>Total breadstuff prepara- tions.....</b>		<b>2,652,085</b>		<b>2,569,333</b>		<b>2,807,465</b>		<b>3,162,627</b>		<b>2,791,156</b>
Distillers' and brewers' grains and malt sprouts... long tons..	65,682	1,424,677	75,503	1,758,404	65,497	1,640,401	76,803	1,914,218	73,628	1,901,974
Malt..... bushels..	224,991	201,554	163,230	147,258	156,497	129,088	117,882	103,099	76,696	86,323

Not stated.

Included in "Logs."



TABLE 185.—Agricultural exports (domestic) of the United States during the five years ending June 30, 1912—Continued.

Article exported.	1908		1909		1910		1911		1912	
	Quantity.	Value.	Quantity.	Value.	Quantity.	Value.	Quantity.	Value.	Quantity.	Value.
<b>VEGETABLE MATTER—continued.</b>										
<b>Grain and grain products—Continued.</b>										
<b>Grain products—Continued.</b>										
<b>Meal and flour—</b>										
Corn meal.....barrels..	654,515	\$2,053,447	452,907	\$1,549,010	331,531	\$1,147,568	463,266	\$1,456,683	439,624	\$1,519,792
Oatmeal.....pounds..	24,484,199	705,853	14,822,944	516,524	15,538,535	521,658	32,416,892	1,043,867	9,112,433	376,188
Rye flour.....barrels..	4,105	16,521	3,857	14,600	3,751	15,240	6,250	24,182	4,306	17,029
Wheat flour.....do....	13,927,247	64,170,508	10,521,161	51,157,366	9,040,987	47,621,467	10,129,435	49,386,946	11,006,487	50,999,797
<b>Total meal and flour.....</b>		<b>66,946,329</b>		<b>53,237,500</b>		<b>49,305,933</b>		<b>51,911,678</b>		<b>52,912,806</b>
<b>All other.....</b>		<b>1,445,289</b>		<b>1,188,518</b>		<b>562,620</b>		<b>1,057,140</b>		<b>1,333,560</b>
<b>Total grain products.....</b>		<b>75,674,108</b>		<b>60,123,419</b>		<b>55,967,129</b>		<b>60,044,317</b>		<b>63,251,992</b>
<b>Total grain and grain products.....</b>		<b>215,462,142</b>		<b>160,076,479</b>		<b>133,320,418</b>		<b>124,262,836</b>		<b>123,095,651</b>
<b>Grasses, dried.....</b>		<b>1,206</b>		<b>(1)</b>		<b>(1)</b>		<b>(1)</b>		<b>(1)</b>
Hay.....long tons..	77,281	1,463,010	64,641	1,147,753	55,007	1,070,907	55,223	1,032,591	59,730	1,039,040
Hops.....pounds..	22,920,480	2,963,167	10,446,884	1,271,629	10,589,254	2,062,140	13,104,774	2,130,972	12,190,663	4,648,505
<b>Lard compounds. (See Meat and meat products.)</b>										
<b>Liquors, alcoholic:</b>										
<b>Distilled spirits—</b>										
Alcohol, including cologne spirits.....proof gallons..	235,752	53,793	103,932	36,719	231,077	64,393	35,231	19,820	25,440	11,336
Brandy.....do....	2,750	4,900	14,718	12,262	(2)	(2)	(2)	(2)	(2)	(2)
Rum.....do....	938,331	1,232,179	926,049	1,237,118	1,138,128	1,474,761	1,129,578	1,476,147	1,410,840	1,827,237
<b>Whisky—</b>										
Bourbon.....do....	129,258	160,914	331,909	365,446	46,301	80,213	58,459	86,714	84,381	124,946
Rye.....do....	172,755	320,935	121,320	210,031	182,002	301,044	133,450	251,453	140,122	267,688
<b>Total whisky.....do....</b>	<b>302,013</b>	<b>481,849</b>	<b>453,229</b>	<b>575,477</b>	<b>228,303</b>	<b>381,257</b>	<b>191,909</b>	<b>338,167</b>	<b>224,503</b>	<b>392,634</b>
<b>Other.....do....</b>	<b>28,391</b>	<b>43,566</b>	<b>11,204</b>	<b>22,391</b>	<b>38,122</b>	<b>57,595</b>	<b>42,246</b>	<b>51,357</b>	<b>23,797</b>	<b>43,123</b>
<b>Total distilled spirits..do....</b>	<b>1,507,237</b>	<b>1,816,287</b>	<b>1,509,132</b>	<b>1,883,967</b>	<b>1,635,630</b>	<b>1,978,006</b>	<b>1,398,964</b>	<b>1,885,491</b>	<b>1,684,580</b>	<b>2,274,330</b>

<b>Malt liquors—</b>											
Bottled.....dozen quarts..	643,230	964,207	635,361	964,992	596,883	877,324	689,063	990,395	754,422	1,101,169	
Unbottled.....gallons..	272,949	55,965	246,525	45,795	390,477	73,859	451,694	85,164	305,394	60,150	
<b>Total malt liquors.....</b>		<b>1,020,172</b>		<b>1,010,787</b>		<b>951,183</b>		<b>1,075,559</b>		<b>1,161,319</b>	
<b>Wines—</b>											
Bottled.....dozen quarts..	6,273	30,830	3,839	19,902	5,962	31,314	} * 1,394,994	518,536	* 957,120	366,260	
Unbottled.....gallons..	438,676	195,160	415,891	181,516	501,348	193,597					
<b>Total wines.....</b>		<b>225,990</b>		<b>201,418</b>		<b>224,911</b>	<b>* 1,394,994</b>	<b>518,536</b>	<b>* 957,120</b>	<b>366,260</b>	
<b>Total alcoholic liquors.....</b>		<b>3,062,449</b>		<b>3,096,172</b>		<b>3,154,100</b>		<b>3,479,586</b>		<b>3,801,909</b>	
<b>Malt. (See Grain and grain products.)</b>											
<b>Malt liquors. (See Liquors, alcoholic.)</b>											
<b>Malt sprouts. (See Grain and grain products.)</b>											
Nursery stock.....		247,844		317,827		324,136		337,988		413,255	
<b>Nuts:</b>											
Peanuts.....pounds..	5,503,685	283,819	5,501,107	242,569	4,484,613	224,779	5,447,185	276,651	5,920,711	305,465	
Other.....		89,205		246,284		156,284		328,151		303,473	
<b>Total nuts.....</b>		<b>373,024</b>		<b>488,853</b>		<b>381,063</b>		<b>604,802</b>		<b>608,938</b>	
<b>Oil cake and oil-cake meal:</b>											
Coconut.....pounds..	(1)	(1)	(1)	(1)	(1)	(1)	(1)	(1)	8,924,033	132,534	
Corn.....do.....	66,127,704	801,787	53,233,890	727,355	49,108,598	689,633	83,884,870	1,115,986	72,490,021	1,035,291	
Cottonseed.....do.....	929,287,467	11,889,415	1,233,750,327	15,805,433	640,088,766	9,071,815	804,596,955	10,153,475	1,293,690,138	17,325,858	
Flaxseed, or linseed.....do.....	696,135,362	9,175,599	682,764,545	9,303,346	652,316,916	9,489,564	559,674,653	8,361,666	596,114,536	9,735,022	
<b>Total.....do.....</b>	<b>1,691,550,533</b>	<b>21,866,761</b>	<b>1,969,748,762</b>	<b>25,836,134</b>	<b>1,341,514,280</b>	<b>19,251,012</b>	<b>1,447,656,478</b>	<b>19,631,127</b>	<b>1,971,218,728</b>	<b>28,228,705</b>	
<b>Oils, vegetable:</b>											
<b>Fixed or expressed—</b>											
Corn.....do.....	27,444,975	1,456,120	24,441,668	1,293,580	11,299,332	643,392	25,316,799	1,573,605	23,866,146	1,526,931	
Cottonseed.....do.....	307,649,933	17,226,451	383,154,968	20,851,380	223,955,002	14,798,063	225,520,944	17,127,369	399,470,973	24,089,223	
Linseed.....gallons..	367,883	172,083	273,029	140,876	228,426	155,858	175,210	164,879	246,965	208,591	
Other.....		206,993		249,360		343,509		292,757		339,391	
<b>Total fixed or expressed.....</b>		<b>19,061,647</b>		<b>22,535,196</b>		<b>15,940,822</b>		<b>19,158,610</b>		<b>26,164,136</b>	
<b>Volatile, or essential—</b>											
Peppermint.....pounds..	141,617	357,555	161,811	288,318	110,407	215,845	123,420	269,034	155,740	422,631	
Other.....		214,765		274,536		322,634		377,588		322,164	
<b>Total volatile, or essential.....</b>		<b>572,320</b>		<b>562,854</b>		<b>538,479</b>		<b>646,622</b>		<b>744,795</b>	
<b>Total vegetable oils.....</b>		<b>19,633,967</b>		<b>23,098,050</b>		<b>16,479,301</b>		<b>19,805,232</b>		<b>26,908,931</b>	

<sup>1</sup> Not stated.

\* Included in "Other," distilled spirits.

<sup>2</sup> Gallons.

TABLE 185.—*Agricultural exports (domestic) of the United States during the five years ending June 30, 1912—Continued.*

Article exported.	1908		1909		1910		1911		1912	
	Quantity.	Value.	Quantity.	Value.	Quantity.	Value.	Quantity.	Value.	Quantity.	Value.
<b>VEGETABLE MATTER—continued.</b>										
Rice, rice meal, etc.:										
Rice.....pounds..	2, 195, 947	\$87, 687	1, 566, 531	\$60, 814	7, 049, 597	\$222, 244	15, 575, 271	\$623, 572	26, 797, 535	\$851, 402
Rice bran, meal, and polish, pounds.....do.....	26, 248, 468	236, 070	18, 944, 898	171, 589	19, 729, 591	179, 037	14, 488, 070	130, 228	12, 649, 036	118, 985
Rice hulls.....do.....		150, 011		119, 279		73, 249		36, 811		181, 229
Total.....do.....		473, 768		351, 682		474, 530		790, 611		1, 151, 616
Root beer.....dozen quarts..	330	441	( <sup>1</sup> )	( <sup>1</sup> )	( <sup>1</sup> )	( <sup>1</sup> )	( <sup>1</sup> )	( <sup>1</sup> )	( <sup>1</sup> )	( <sup>1</sup> )
Roots, herbs, and barks, n. e. s. ....do.....		435, 041		395, 801		476, 837		563, 862		549, 877
Seeds:										
Cottonseed.....pounds..	28, 478, 473	353, 213	51, 626, 741	632, 561	24, 931, 099	406, 120	13, 224, 347	209, 944	64, 060, 776	727, 100
Flaxseed, or linseed.....bushels..	4, 277, 313	5, 721, 337	882, 899	1, 092, 539	65, 193	118, 329	976	2, 520	4, 323	12, 160
Grass and clover seed—										
Clover.....pounds..	3, 547, 747	579, 199	16, 186, 133	1, 706, 780	6, 977, 685	832, 676	4, 359, 167	577, 929	1, 874, 682	317, 772
Timothy.....do.....	25, 550, 134	1, 247, 960	23, 346, 614	1, 009, 557	27, 113, 056	1, 115, 526	9, 307, 428	817, 377	4, 354, 556	620, 942
Other.....do.....		495, 245		474, 519		601, 611		334, 169		534, 578
Total grass and clover seed.....do.....		2, 322, 404		3, 190, 856		2, 549, 813		1, 729, 475		1, 473, 292
All other seeds.....do.....		286, 734		340, 667		411, 156		533, 127		686, 250
Total seeds.....do.....		8, 683, 688		5, 256, 623		3, 485, 418		2, 475, 066		2, 898, 802
Spices.....do.....		43, 587		38, 444		52, 755		58, 989		74, 023
Spirits, distilled. ( <i>See</i> Liquors, alco- holic.).....do.....										
Starch.....pounds..	48, 125, 851	1, 142, 054	33, 228, 278	780, 155	51, 535, 570	1, 274, 773	158, 239, 178	3, 137, 552	83, 644, 749	1, 965, 401
Straw.....long tons.	( <sup>1</sup> )	6, 552	( <sup>1</sup> )	8, 293	1, 087	13, 884	922	10, 679	1, 030	11, 559
Sugar, molasses, and sirup:										
Molasses.....gallons..	3, 320, 419	425, 757	3, 973, 908	440, 225	1, 505, 355	216, 336	3, 386, 811	354, 108	9, 513, 441	984, 636
Sirup.....do.....	13, 181, 095	1, 961, 670	13, 865, 756	2, 243, 201	13, 457, 307	2, 258, 640	12, 001, 799	1, 752, 118	19, 146, 986	2, 539, 055

<b>Sugar—</b>										
Raw.....pounds..	13,285	523	60,882	1,742	54,447	2,051	(2)	(2)	(2)	(2)
Refined.....do.....	25,497,358	973,661	79,885,415	2,783,334	125,452,575	5,396,009	54,947,444	2,244,379	79,594,034	3,681,072
Total sugar.....do.....	25,510,643	974,184	79,946,297	2,785,076	125,507,022	5,398,060	54,947,444	2,244,379	79,594,034	3,681,072
Total sugar, molasses, and sirup.....do.....		3,361,611		5,468,502		7,873,036		4,350,605		7,204,763
<b>Teazels.....do.....</b>		2,056		(1)		(1)		(1)		(1)
<b>Tobacco:</b>										
Leaf.....pounds..	323,033,034	34,342,293	282,688,917	30,757,931	353,372,672	38,017,260	351,568,138	39,159,708	375,373,131	43,146,013
Stems and trimmings.....do.....	7,779,624	384,864	5,212,029	144,969	3,823,402	98,126	3,758,934	95,612	4,472,189	105,844
Total.....do.....	330,812,658	34,727,157	287,900,946	30,902,900	357,196,074	38,115,386	355,327,072	39,255,320	379,845,320	43,251,857
<b>Vegetables:</b>										
Fresh or dried—										
Beans and peas.....bushels..	306,939	708,201	298,209	702,819	365,721	973,231	288,638	814,663	341,268	1,011,466
Onions.....do.....	174,820	184,166	366,989	318,051	254,255	208,134	234,289	224,037	313,299	307,132
Potatoes.....do.....	1,203,894	1,077,612	763,651	715,701	999,476	759,277	2,383,887	1,535,630	1,237,276	1,414,297
Total fresh or dried....do....	1,685,653	1,969,979	1,428,849	1,736,571	1,619,452	1,940,642	2,906,814	2,574,330	1,891,843	2,732,895
Prepared or preserved—										
Canned.....do.....		621,987		728,111		782,973		1,061,259		1,822,357
Other.....do.....		1,303,328		1,295,784		1,483,704		1,909,502		1,988,866
Total prepared or preserved.....do.....		1,925,315		2,023,895		2,266,677		2,970,761		3,811,223
Total vegetables.....do.....		3,895,294		3,760,466		4,207,319		5,545,091		6,544,118
Vinegar.....gallons..	109,263	15,841	106,903	15,100	114,747	12,861	130,588	21,876	185,580	37,770
Wines. (See Liquors, alcoholic.)		37,658		50,455		71,245		143,971		175,347
Yeast.....do.....										
Total vegetable matter, including forest products.....do.....		869,206,323		776,634,500		797,831,221		950,786,405		970,340,724
Total vegetable matter, excluding forest products.....do.....		778,844,250		704,192,046		712,800,991		847,747,513		862,218,470
Total agricultural exports, including forest products.....do.....		1,107,758,477		975,680,576		956,188,655		1,133,833,294		1,156,556,022
Total agricultural exports, excluding forest products.....do.....		1,017,396,404		903,238,122		871,158,425		1,030,794,402		1,048,433,768

<sup>1</sup> Not stated.

<sup>2</sup> Included in "Refined," sugar.

TABLE 186.—Foreign trade of the United States in agricultural products, 1851–1912.

[Compiled from reports of Foreign Commerce and Navigation of the United States. All values are gold.]

Year ending June 30—	Agricultural exports. <sup>1</sup>		Agricultural imports. <sup>1</sup>			Excess of exports (+) or of imports (–) agricultural.
	Domestic.		Foreign.	Total.	Percentage of all imports.	
	Total.	Percentage of all domestic exports.				
1851.	\$146,717,431	82.1	\$5,084,886	\$60,513,449	28.7	+\$91,288,868
1852.	125,183,749	80.8	5,897,138	61,747,933	29.8	+ 69,332,954
1853.	155,461,445	81.9	6,820,517	71,499,465	27.1	+ 90,782,497
1854.	172,320,260	80.0	11,528,791	71,720,047	24.1	+112,129,004
1855.	149,101,277	77.4	9,601,059	81,726,640	31.7	+ 76,975,696
1856.	222,409,601	83.5	6,451,870	102,541,703	33.0	+126,319,168
1857.	232,180,205	83.2	8,182,890	135,226,318	38.2	+107,136,777
1858.	205,853,748	81.9	13,739,733	102,452,331	38.9	+117,111,150
1859.	226,135,020	81.2	9,054,220	126,236,317	38.1	+108,952,923
1860.	260,280,413	82.3	10,577,008	129,816,165	36.7	+141,041,256
1861.	154,094,839	75.2	9,315,314	113,329,585	39.9	+ 50,080,568
1862.	140,463,928	78.2	5,569,056	91,263,088	48.2	+ 54,769,896
1863.	137,512,273	73.9	8,162,395	102,886,713	42.3	+ 42,787,955
1864.	102,794,359	71.6	9,037,218	138,124,440	43.6	– 26,292,863
1865.	84,886,860	62.0	17,876,028	114,031,753	47.8	– 11,268,865
1866.	278,670,278	82.6	5,793,649	164,801,739	37.9	+119,602,188
1867.	214,258,245	76.6	9,244,181	141,622,826	35.8	+ 81,879,600
1868.	206,979,580	76.8	6,709,785	157,638,217	44.1	+ 56,051,148
1869.	205,330,174	74.6	7,067,011	185,348,661	44.4	+ 27,048,524
1870.	296,962,357	78.9	10,667,193	191,559,361	43.9	+116,070,189
1871.	330,034,934	77.0	9,002,337	222,700,936	42.8	+116,336,335
1872.	332,936,080	77.7	9,205,158	274,146,298	43.8	+ 67,994,940
1873.	396,240,107	78.5	9,574,000	277,604,621	43.2	+128,209,486
1874.	453,862,070	79.7	9,629,988	267,414,990	47.1	+196,077,068
1875.	389,409,703	78.0	7,406,702	261,618,732	49.1	+135,197,673
1876.	410,884,027	78.2	8,450,386	234,993,224	51.0	+184,341,189
1877.	435,354,451	73.8	7,296,110	249,281,945	55.2	+193,368,616
1878.	531,637,041	78.1	9,419,767	236,112,137	54.0	+304,944,671
1879.	557,321,801	79.8	8,079,701	233,623,846	52.4	+317,777,656
1880.	694,315,497	84.3	7,173,664	314,617,480	47.1	+386,871,661
1881.	738,123,799	83.5	11,189,658	298,283,101	46.4	+451,030,356
1882.	557,620,540	76.0	9,857,878	330,375,047	45.6	+237,103,371
1883.	626,426,608	77.9	11,282,895	325,757,806	45.0	+311,951,697
1884.	547,952,579	75.6	8,749,894	319,053,331	47.8	+237,649,142
1885.	554,051,146	76.2	9,077,454	277,340,305	48.0	+285,788,294
1886.	501,313,738	75.3	7,734,192	306,011,332	48.2	+203,036,598
1887.	536,938,387	76.4	7,965,572	325,652,754	47.0	+219,251,205
1888.	505,402,327	73.9	7,031,986	339,199,344	46.9	+173,234,969
1889.	536,828,565	73.5	6,895,482	365,586,061	49.1	+178,137,986
1890.	634,855,869	75.1	6,908,820	384,100,435	48.7	+257,664,254
1891.	652,407,931	74.8	6,109,781	420,211,949	49.7	+238,305,763
1892.	803,122,045	79.1	6,638,755	436,697,057	52.8	+373,063,743
1893.	621,201,671	74.8	7,155,979	425,657,448	49.1	+202,700,202
1894.	636,633,747	73.2	9,586,876	365,160,319	55.8	+281,060,304
1895.	558,385,261	70.4	7,934,115	373,115,985	51.0	+193,203,991
1896.	574,898,864	66.5	10,916,730	391,029,407	50.1	+194,285,587
1897.	880,755,193	66.8	9,707,782	400,871,468	52.4	+298,591,507
1898.	859,018,946	71.0	10,409,348	314,291,796	51.0	+555,136,498
1899.	792,811,733	65.9	12,134,268	355,514,881	51.0	+449,431,120
1900.	844,616,530	61.6	11,263,253	420,139,288	49.4	+435,740,495
1901.	951,628,331	65.2	11,293,045	391,931,051	47.6	+570,990,325
1902.	857,118,533	63.2	10,308,306	413,744,557	45.8	+453,677,282
1903.	878,480,557	63.1	13,505,343	456,199,325	44.5	+435,786,575
1904.	859,160,264	59.9	12,625,026	461,434,851	46.6	+410,350,439
1905.	826,904,777	55.4	12,316,525	553,851,214	49.6	+285,370,088
1906.	976,047,104	56.8	10,856,259	554,175,242	45.2	+432,728,121
1907.	1,054,405,416	56.9	11,613,519	626,836,808	43.7	+439,182,127
1908.	1,017,396,404	55.5	10,298,514	559,690,121	45.2	+488,004,797
1909.	903,238,122	55.1	9,584,934	638,612,692	48.7	+274,210,364
1910.	871,158,425	50.9	14,469,627	687,509,155	44.2	+198,118,930
1911.	1,030,794,402	51.2	14,664,548	680,204,932	44.5	+365,254,218
1912.	1,048,433,768	48.3	12,107,056	783,457,471	47.4	+277,083,953
Average:						
1851–1855.	149,756,832	80.4	7,786,478	69,441,507	28.1	+ 88,101,803
1856–1860.	229,371,677	82.4	9,601,144	118,860,567	37.0	+120,112,254
1861–1865.	123,950,452	72.8	9,992,002	111,927,116	43.8	+ 22,015,338
1866–1870.	240,440,127	78.1	7,896,364	168,194,161	41.2	+ 80,142,300
1871–1875.	380,496,579	78.3	8,963,637	260,697,115	45.1	+128,763,101
1876–1880.	525,902,563	79.2	8,083,926	253,725,726	51.5	+280,260,763
1881–1885.	604,834,934	78.1	10,031,556	310,161,918	46.5	+304,704,572
1886–1890.	543,637,777	74.8	7,307,210	344,109,985	48.0	+206,265,002
1891–1895.	654,350,251	74.7	7,485,101	404,168,552	51.5	+257,666,800
1896–1900.	752,120,133	66.2	10,886,276	376,369,368	50.8	+386,637,041
1901–1905.	874,657,492	61.4	12,009,649	455,432,200	46.8	+431,234,941
1906–1910.	964,449,094	55.1	11,364,571	609,364,796	45.3	+366,448,869

<sup>1</sup> Not including forest products.

TABLE 187.—Exports of selected domestic agricultural products, 1851-1912.

[Compiled from reports of Foreign Commerce and Navigation of the United States. Where figures are lacking, either there were no exports or they were not separately classified for publication. For "Beef, salted or pickled," and "Pork, salted or pickled," barrels, 1851-1865, were reduced to pounds at the rate of 200 pounds per barrel, and tierces, 1855-1865, at the rate of 300 pounds per tierce; cottonseed oil, 1910, pounds reduced to gallons at the rate of 7.5 pounds per gallon. It is assumed that 1 barrel of corn meal is the product of 4 bushels of corn, and 1 barrel of wheat flour the product of 5 bushels of wheat prior to 1880 and of 4½ bushels of wheat in 1880 and subsequently.]

Year ending June 30—	Cattle.	Cheese.	Packing-house products.				Beef and its products—total, as far as ascertainable in pounds. <sup>1</sup>
			Beef, cured—salted or pickled.	Beef, fresh.	Beef oils—oleo oil.	Beef (mostly)—tallow.	
	Number.	Pounds.	Pounds.	Pounds.	Pounds.	Pounds.	Pounds.
1851.....	1,350	10,361,189	18,129,600			8,198,278	26,327,878
1852.....	1,078	6,650,420	24,451,800			4,767,620	29,218,820
1853.....	1,076	3,763,932	25,208,200			3,926,598	29,134,798
1854.....	1,022	7,003,974	25,244,000			0,325,471	34,569,471
1855.....	1,501	4,846,568	29,560,800			11,866,992	41,427,792
1856.....	2,478	8,737,029	25,437,800			7,458,471	32,896,271
1857.....	4,325	6,453,072	15,668,000			5,698,315	21,366,315
1858.....	28,247	8,098,527	23,961,400			8,283,812	32,245,212
1859.....	32,513	7,103,323	30,801,000			7,103,465	37,904,465
1860.....	27,501	15,515,799	38,858,800			15,269,535	54,128,335
1861.....	8,885	32,361,428	25,640,200			29,718,364	55,358,564
1862.....	3,634	34,052,678	27,204,400			46,773,768	73,978,168
1863.....	5,509	42,045,054	29,259,800			63,792,754	93,052,554
1864.....	6,191	47,751,329	35,666,400			55,197,914	90,864,314
1865.....	9,589	53,154,318	27,129,200			30,884,500	58,013,700
1866.....	7,730	36,411,985	19,053,800			19,364,686	38,418,486
1867.....	10,221	52,352,127	14,182,562			23,296,931	37,479,493
1868.....	16,120	51,097,203	22,683,531			22,682,412	45,365,943
1869.....	39,960	37,960,367	27,299,197			20,534,628	47,833,825
1870.....	27,530	57,296,327	26,727,773			37,513,056	64,240,829
1871.....	20,530	63,698,867	43,880,217			33,859,317	77,739,534
1872.....	28,033	66,204,025	26,652,094			76,151,218	102,803,312
1873.....	35,455	80,366,540	31,605,196			79,170,558	110,775,558
1874.....	56,067	90,611,077	36,036,537			101,755,631	137,792,168
1875.....	57,211	101,010,853	48,243,251			65,461,619	113,704,870
1876.....	51,593	97,676,264	36,596,150			72,432,775	109,028,925
1877.....	50,001	107,364,666	39,155,153	49,210,990		91,472,803	179,838,943
1878.....	80,040	123,783,736	38,831,379	54,046,771	1,698,401	85,505,919	180,082,470
1879.....	136,720	141,654,474	36,950,563	54,025,832	12,687,318	99,963,752	203,627,465
1880.....	182,756	127,553,907	45,237,472	84,717,194	19,844,256	110,767,627	260,566,549
1881.....	185,707	147,995,614	40,698,649	106,004,812	26,327,676	96,403,372	269,434,509
1882.....	108,110	127,989,782	45,899,737	69,586,466	19,714,338	50,474,210	187,832,197
1883.....	104,444	97,220,467	41,680,623	81,064,373	29,031,064	38,100,098	192,536,459
1884.....	190,518	112,869,575	42,379,911	120,784,064	37,785,159	63,091,103	266,219,082
1885.....	135,890	111,992,990	48,143,711	115,780,830	37,120,217	50,431,719	252,210,842
1886.....	119,065	91,877,235	58,903,370	99,423,362	27,729,585	40,919,951	228,729,576
1887.....	106,459	81,255,994	36,287,188	83,560,874	45,712,985	63,278,403	272,916,803
1888.....	140,208	88,008,458	48,980,269	93,498,273	30,146,595	92,453,052	307,379,422
1889.....	205,786	84,949,828	55,006,399	137,895,391	28,102,534	77,844,555	352,260,216
1890.....	394,836	95,376,053	97,508,419	173,237,596	68,218,098	112,745,370	536,986,026
1891.....	374,679	82,133,876	90,258,979	194,045,638	80,231,035	111,689,251	589,447,206
1892.....	394,607	82,100,221	70,204,736	220,554,617	91,581,702	89,780,010	561,713,690
1893.....	287,094	81,350,923	58,423,963	206,294,724	113,939,363	61,819,153	523,944,938
1894.....	359,278	73,852,134	62,682,667	193,891,824	123,285,895	54,601,524	495,624,104
1895.....	331,722	60,448,421	62,473,325	191,338,487	78,068,878	25,864,300	432,799,823
1896.....	372,461	36,777,291	70,709,209	224,783,225	103,276,756	52,759,212	521,804,584
1897.....	392,190	50,944,617	67,712,940	290,395,930	113,506,152	75,108,834	606,547,427
1898.....	439,255	53,167,280	44,314,479	274,768,074	132,579,277	81,744,809	576,433,797
1899.....	389,490	38,198,573	46,564,876	282,139,974	142,390,492	107,361,009	623,970,458
1900.....	397,286	48,419,353	47,306,513	329,078,609	146,739,681	89,030,942	674,284,723

<sup>1</sup> Includes beef, canned; beef, cured—salted or pickled; beef, cured—other; beef, fresh; oils—oleo oil; oleomargarin; tallow.

TABLE 187.—Exports of selected domestic agricultural products, 1851-1912—Continued.

Year ending June 30—	Cattle.	Cheese.	Packing-house products.				Beef and its products—total, as far as ascertainable in pounds.
			Beef, cured—salted or pickled.	Beef, fresh.	Beef oils—oleo oil.	Beef (mostly)—tallow.	
	<i>Number.</i>	<i>Pounds.</i>	<i>Pounds.</i>	<i>Pounds.</i>	<i>Pounds.</i>	<i>Pounds.</i>	<i>Pounds.</i>
1901.....	459, 218	39, 813, 517	55, 312, 632	351, 748, 333	161, 651, 413	77, 166, 889	705, 104, 772
1902.....	392, 884	27, 203, 184	48, 632, 727	301, 824, 473	138, 546, 088	34, 065, 758	596, 254, 520
1903.....	402, 178	18, 987, 178	52, 801, 220	254, 795, 963	126, 010, 339	27, 368, 924	546, 055, 244
1904.....	593, 409	23, 335, 172	57, 584, 710	299, 579, 671	165, 183, 839	76, 924, 174	663, 147, 095
1905.....	467, 806	10, 134, 424	55, 934, 705	236, 486, 568	145, 228, 245	63, 536, 992	575, 874, 718
1906.....	584, 239	16, 562, 451	81, 088, 098	268, 054, 227	209, 658, 075	97, 567, 156	732, 884, 572
1907.....	423, 051	17, 285, 230	62, 645, 281	281, 651, 502	195, 337, 176	127, 857, 739	689, 752, 420
1908.....	349, 210	8, 439, 031	46, 958, 367	201, 154, 105	212, 541, 157	91, 397, 507	579, 303, 478
1909.....	207, 542	6, 822, 842	44, 494, 210	122, 952, 671	179, 965, 246	53, 332, 767	418, 844, 332
1910.....	139, 430	2, 846, 709	36, 554, 266	75, 729, 666	126, 091, 075	29, 379, 992	286, 295, 874
1911.....	150, 100	10, 366, 605	40, 283, 749	42, 510, 731	138, 696, 906	29, 813, 154	265, 923, 983
1912.....	105, 506	6, 337, 559	38, 087, 907	15, 264, 320	126, 467, 124	39, 451, 419	233, 924, 626
Average:							
1851-1855.....	1, 205	6, 525, 217	24, 518, 880	.....	.....	7, 616, 872	32, 135, 752
1856-1860.....	19, 013	9, 181, 550	26, 945, 400	.....	.....	8, 762, 636	35, 708, 036
1861-1865.....	6, 762	41, 872, 961	28, 980, 000	.....	.....	45, 273, 460	74, 253, 460
1866-1870.....	.....	47, 423, 602	21, 989, 373	.....	.....	24, 678, 343	46, 667, 715
1871-1875.....	39, 459	80, 378, 272	37, 283, 459	.....	.....	71, 279, 669	108, 563, 128
1876-1880.....	100, 222	119, 606, 609	39, 354, 143	.....	.....	92, 028, 575	186, 628, 870
1881-1885.....	144, 934	120, 013, 686	43, 760, 526	98, 644, 109	29, 995, 691	59, 842, 100	233, 766, 618
1886-1890.....	193, 271	88, 303, 514	59, 337, 129	117, 523, 099	39, 982, 019	77, 454, 266	339, 654, 333
1891-1895.....	349, 476	75, 977, 115	68, 814, 334	201, 225, 058	97, 429, 375	68, 762, 848	520, 705, 954
1896-1900.....	398, 136	45, 501, 459	55, 321, 603	280, 233, 162	127, 698, 472	81, 200, 961	600, 608, 198
1901-1905.....	483, 099	23, 894, 695	54, 053, 199	288, 887, 002	147, 323, 985	55, 812, 547	617, 287, 270
1906-1910.....	340, 694	10, 391, 253	54, 348, 044	189, 908, 434	184, 722, 666	79, 907, 032	541, 416, 135

Year ending June 30—	Packing-house products—Continued.					Apples, fresh.	Corn and corn meal (converted to corn).
	Pork, cured—bacon.	Pork, cured—hams. <sup>1</sup>	Pork, cured—salted or pickled.	Pork—lard.	Pork and its products—total, as far as ascertainable in pounds. <sup>2</sup>		
	<i>Pounds.</i>	<i>Pounds.</i>	<i>Pounds.</i>	<i>Pounds.</i>	<i>Pounds.</i>	<i>Barrels.</i>	<i>Bushels.</i>
1851.....	18, 027, 302	.....	33, 041, 200	19, 683, 082	70, 751, 584	28, 842	4, 241, 299
1852.....	5, 746, 816	.....	16, 676, 400	21, 281, 951	43, 705, 167	18, 411	3, 351, 495
1853.....	18, 390, 027	.....	25, 976, 200	24, 435, 014	68, 801, 241	45, 075	3, 123, 381
1854.....	45, 953, 473	.....	44, 029, 400	44, 450, 154	134, 433, 027	15, 326	8, 798, 428
1855.....	38, 188, 989	.....	59, 752, 000	39, 025, 492	136, 966, 481	33, 959	8, 876, 417
1856.....	41, 748, 092	.....	56, 279, 000	37, 582, 271	135, 609, 363	74, 287	11, 466, 708
1857.....	43, 863, 539	.....	28, 902, 600	40, 246, 544	113, 012, 683	33, 201	8, 575, 334
1858.....	20, 954, 374	.....	31, 975, 000	33, 022, 286	85, 951, 660	27, 711	5, 716, 693
1859.....	11, 989, 694	.....	41, 148, 400	28, 362, 706	81, 500, 800	32, 979	2, 755, 538
1860.....	25, 844, 610	.....	40, 948, 600	40, 289, 519	107, 082, 729	78, 909	4, 248, 991
1861.....	50, 264, 267	.....	31, 297, 400	47, 908, 911	129, 470, 578	112, 523	11, 491, 496
1862.....	141, 212, 786	.....	61, 820, 400	118, 573, 307	321, 606, 493	60, 767	19, 919, 178
1863.....	218, 243, 679	.....	65, 570, 400	155, 336, 596	439, 150, 605	174, 602	17, 151, 693
1864.....	110, 886, 446	.....	63, 519, 400	97, 190, 765	271, 596, 611	183, 969	5, 146, 122
1865.....	46, 053, 034	.....	41, 786, 800	44, 480, 136	132, 319, 970	120, 317	3, 616, 653
1866.....	37, 588, 930	.....	30, 056, 788	30, 110, 451	97, 756, 169	51, 612	14, 465, 751
1867.....	25, 648, 226	.....	27, 374, 877	45, 608, 031	98, 631, 134	29, 577	16, 026, 947
1868.....	43, 659, 064	.....	28, 690, 133	64, 555, 462	136, 904, 659	19, 874	12, 493, 522
1869.....	49, 228, 165	.....	24, 439, 832	41, 887, 545	115, 555, 542	.....	8, 286, 665
1870.....	38, 968, 256	.....	24, 639, 831	35, 808, 530	99, 416, 617	38, 157	2, 140, 487

<sup>1</sup> Subsequent to 1904, including shoulders.  
<sup>2</sup> Includes lard; lard, neutral; pork, canned; pork, cured—bacon; pork, cured—hams; pork, cured—salted or pickled; pork, fresh.

TABLE 187.—Exports of selected domestic agricultural products, 1851-1912—Continued.

Year ending June 30—	Packing-house products—Continued.					Apples, fresh.	Corn and corn meal (converted to corn).
	Pork, cured— bacon.	Pork, cured— hams.	Pork, cured— salted or pickled.	Pork— lard.	Pork and its products— total, as far as ascertainable in pounds.		
	<i>Pounds.</i>	<i>Pounds.</i>	<i>Pounds.</i>	<i>Pounds.</i>	<i>Pounds.</i>	<i>Barrels.</i>	<i>Bushels.</i>
1871.....	71,446,854	.....	39,250,750	80,037,297	190,734,901	49,088	10,673,553
1872.....	246,208,143	.....	57,169,518	199,651,660	508,029,321	36,508	35,727,010
1873.....	395,381,737	.....	64,147,461	230,534,207	690,063,405	241,663	40,154,374
1874.....	347,405,405	.....	70,482,379	205,527,471	623,415,255	44,928	35,985,834
1875.....	250,286,549	.....	56,152,331	166,869,393	473,308,273	276,209	30,025,036
1876.....	327,730,172	.....	54,195,118	168,405,839	550,331,129	64,472	50,910,532
1877.....	460,057,146	.....	69,671,894	234,741,233	764,470,273	147,065	72,652,611
1878.....	592,814,351	.....	342,766,254	71,889,255	1,007,469,860	101,617	87,192,110
1879.....	732,249,576	.....	84,401,676	326,658,686	1,143,309,938	505,018	67,884,892
1880.....	759,773,109	.....	95,949,780	374,979,286	1,230,702,175	407,911	99,572,392
1881.....	673,274,361	73,670,184	107,928,086	378,142,496	1,233,015,127	1,117,065	93,648,147
1882.....	428,481,482	39,545,158	80,447,466	250,367,740	798,841,846	176,704	44,340,683
1883.....	294,118,759	46,139,911	62,116,302	224,718,474	627,093,446	313,921	41,655,653
1884.....	341,579,410	47,919,958	60,363,313	265,094,719	715,142,817	105,400	46,258,606
1885.....	345,924,217	54,202,902	71,649,365	283,216,339	755,416,926	668,867	52,876,456
1886.....	369,423,351	50,365,445	87,196,966	293,728,019	800,784,530	744,539	64,829,617
1887.....	364,417,744	55,605,211	85,869,367	321,533,746	827,349,998	591,868	41,368,584
1888.....	331,306,703	44,132,980	58,836,966	297,740,007	732,079,843	489,570	25,360,869
1889.....	357,377,399	42,847,247	64,110,845	318,242,990	782,601,275	492,406	70,841,673
1890.....	531,899,677	76,591,279	79,788,868	471,083,598	1,199,642,885	453,506	103,418,709
1891.....	514,675,557	84,410,108	81,317,364	498,343,927	1,179,565,831	135,207	32,041,529
1892.....	507,919,380	76,856,559	80,336,481	460,045,776	1,125,536,392	938,743	76,602,285
1893.....	391,158,175	82,178,154	52,459,722	265,693,501	893,002,196	408,014	47,121,894
1894.....	416,657,577	86,970,571	63,575,881	447,566,867	1,015,939,543	78,580	66,489,529
1895.....	452,549,976	105,494,123	58,266,893	474,895,274	1,092,024,847	818,711	28,585,405
1896.....	425,352,187	129,036,351	69,498,373	509,534,256	1,134,165,823	360,002	101,100,375
1897.....	500,399,448	165,247,302	66,768,920	568,315,640	1,302,037,734	1,503,981	178,817,417
1898.....	650,108,933	200,185,861	88,133,078	709,344,045	1,659,996,202	605,390	212,055,543
1899.....	562,651,480	225,846,750	137,197,200	711,259,851	1,678,265,645	380,222	177,255,046
1900.....	512,153,729	196,414,412	133,199,683	661,813,663	1,538,024,466	526,636	213,123,412
1901.....	456,122,741	216,571,803	138,643,611	611,357,514	1,462,369,849	883,673	181,405,473
1902.....	383,150,624	227,653,232	115,896,275	556,840,222	1,337,315,909	459,719	28,028,688
1903.....	207,336,000	214,183,365	95,287,374	490,755,821	1,042,119,570	1,656,129	76,639,261
1904.....	249,665,941	194,948,864	112,224,861	561,302,643	1,146,255,441	2,018,262	58,222,061
1905.....	262,246,635	203,458,724	118,887,189	610,238,899	1,220,031,970	1,499,942	90,293,483
1906.....	361,210,563	194,267,949	141,820,720	741,516,886	1,464,960,356	1,208,989	119,893,833
1907.....	250,418,699	209,481,496	166,427,409	627,559,660	1,268,065,412	1,539,267	86,368,228
1908.....	241,189,929	221,769,634	149,505,937	603,413,770	1,237,210,760	1,049,545	55,063,860
1909.....	244,578,674	212,170,224	52,354,980	528,722,933	1,053,142,056	896,279	37,665,040
1910.....	152,163,107	146,885,385	40,031,599	362,927,671	707,110,062	922,078	38,128,498
1911.....	156,675,310	157,709,316	45,729,471	476,107,857	879,455,066	1,721,106	65,614,522
1912.....	208,574,208	204,044,491	56,321,469	532,255,865	1,071,951,724	1,456,381	41,797,291
Average:							
1851-1855.....	25,261,321	.....	35,895,040	29,775,139	90,931,500	28,323	5,678,204
1856-1860.....	28,880,062	.....	39,850,720	35,900,665	104,631,447	49,397	6,552,653
1861-1865.....	113,332,028	.....	52,798,880	92,697,943	258,828,851	131,616	11,464,943
1866-1870.....	39,018,528	.....	27,040,292	43,594,004	109,652,824	.....	10,682,674
1871-1875.....	262,145,738	.....	57,440,488	176,524,006	496,110,231	129,679	30,513,161
1876-1880.....	574,524,871	.....	75,221,545	289,510,260	939,256,675	299,217	79,642,495
1881-1885.....	416,675,646	52,295,623	76,500,906	280,307,954	825,902,032	476,391	55,755,909
1886-1890.....	390,884,975	53,888,432	75,160,602	340,465,672	860,491,706	644,378	61,163,890
1891-1895.....	456,712,223	87,181,903	67,191,263	449,309,069	1,061,213,762	475,851	50,168,128
1896-1900.....	530,133,155	183,346,135	98,959,451	632,053,491	1,462,497,974	675,246	176,470,359
1901-1905.....	311,704,388	131,363,198	116,187,862	566,099,020	1,241,618,548	1,303,545	86,917,793
1906-1910.....	249,912,194	196,914,938	110,028,129	572,828,184	1,146,097,729	1,123,232	67,423,892



TABLE 187.—Exports of selected domestic agricultural products, 1851-1912—Continued.

Year ending June 30—	Hops.	Oils, vegetable— cotton- seed oil.	Rice and rice bran, meal, and polish.	Sugar, raw and refined.	Wheat.	Wheat flour.	Wheat and wheat flour (converted to wheat).
	<i>Pounds.</i>	<i>Gallons.</i>	<i>Pounds.</i>	<i>Pounds.</i>	<i>Bushels.</i>	<i>Barrels.</i>	<i>Bushels.</i>
1851	110,360		63,354,000	3,251,369	1,026,725	2,202,335	12,038,400
1852	238,008		71,839,800	2,498,390	2,694,540	2,799,339	16,691,235
1853	245,647		40,624,200	5,827,331	3,890,141	2,920,918	18,494,731
1854	260,026		63,072,600	9,893,751	8,036,665	4,022,386	28,148,595
1855	4,021,816		39,421,600	11,160,945	798,884	1,204,540	6,821,584
1856	1,048,515		67,616,000	9,271,191	8,154,877	3,510,626	25,708,007
1857	924,538		68,322,800	5,338,247	14,570,331	3,712,053	33,130,596
1858	458,889		58,122,200	7,201,120	8,926,196	3,512,169	26,487,041
1859	587,953		77,070,400	6,558,757	3,002,016	2,431,824	15,161,136
1860	273,257		81,632,600	4,466,031	4,155,153	2,611,596	17,213,133
1861	8,835,837		43,512,400	6,511,134	31,238,057	4,323,756	52,856,837
1862	4,860,046		4,221,600	2,755,252	37,289,572	4,882,033	61,699,737
1863	8,864,081		1,694,800	3,595,009	36,160,414	4,390,055	58,110,689
1864	5,851,165		2,176,800	2,328,483	23,681,712	3,557,347	41,468,444
1865	3,671,371		983,200	1,900,002	9,937,876	2,641,298	23,144,367
1866	349,987		2,212,901	4,460,138	5,579,103	2,183,500	16,494,353
1867	1,001,603		1,394,007	8,300,175	6,146,411	1,900,106	12,646,941
1868	532,038		3,079,043	2,218,150	15,940,899	2,076,423	26,323,014
1869	11,269,555		2,232,833	3,167,523	17,557,836	2,431,873	29,717,201
1870	16,356,231		2,133,014	4,427,576	36,584,115	3,463,333	53,900,780
1871	3,273,653		445,842	3,841,078	34,304,906	3,653,841	52,574,111
1872	3,061,244	547,165	403,835	4,478,492	26,423,080	2,514,535	35,995,755
1873	1,795,437	709,576	276,637	10,083,363	39,204,285	2,562,886	52,014,715
1874	117,558	782,067	558,922	10,132,911	71,039,929	4,094,094	91,610,398
1875	3,066,703	417,387	277,337	24,152,388	53,047,177	3,973,128	72,912,817
1876	9,191,589	281,054	439,991	51,863,691	55,073,122	3,935,512	74,750,682
1877	9,581,108	1,705,422	1,306,982	39,751,324	40,325,611	3,643,665	57,043,936
1878	18,458,782	4,992,349	631,105	44,093,092	72,404,966	3,947,333	92,141,626
1879	5,458,159	5,352,530	740,136	72,352,964	122,353,931	5,629,714	150,502,740
1880	9,739,566	6,997,796	183,534	30,142,004	153,252,795	6,011,419	180,304,181
1881	8,990,655	3,444,084	150,451	22,252,833	150,565,477	7,945,786	186,321,514
1882	5,867,363	713,549	143,289	13,814,005	95,271,802	5,915,686	121,892,383
1883	7,817,228	415,611	136,143	28,542,115	106,385,828	9,205,664	147,811,316
1884	13,516,643	3,605,946	163,519	76,122,813	70,349,012	9,152,260	111,534,182
1885	7,055,289	6,364,279	663,502	252,740,420	84,653,714	10,648,145	132,570,366
1886	13,665,661	6,240,139	1,700,576	164,429,490	57,759,209	8,179,241	94,565,793
1887	260,721	4,126,630	4,126,630	190,804,677	101,971,949	11,518,449	153,804,969
1888	6,793,818	4,458,597	1,858,735	34,646,157	65,789,261	11,963,574	119,625,344
1889	12,589,262	2,690,700	2,890,027	14,259,414	46,414,129	9,374,803	88,600,743
1890	7,540,854	13,384,385	3,681,979	27,225,469	54,387,767	12,231,711	109,430,467
1891	8,736,080	11,003,160	3,490,895	108,433,474	55,131,948	11,344,304	106,151,316
1892	12,604,686	13,859,278	10,256,796	14,850,391	157,280,351	15,759,769	225,665,511
1893	11,367,030	9,462,074	13,711,798	20,746,327	117,121,109	16,620,339	191,912,635
1894	17,472,975	14,958,309	10,766,249	15,468,496	88,415,230	16,859,533	164,283,129
1895	17,523,388	21,187,728	1,623,336	9,529,008	76,102,704	15,268,892	144,812,718
1896	16,765,254	19,445,848	15,031,554	9,402,524	60,650,080	14,620,864	126,443,968
1897	11,426,241	27,198,882	3,905,754	8,305,219	79,562,020	14,569,545	145,124,972
1898	17,161,669	40,230,784	6,200,987	6,508,290	148,231,261	15,349,943	217,306,005
1899	21,145,512	50,627,219	15,334,689	9,865,347	139,432,815	18,485,690	222,618,420
1900	12,639,474	46,902,390	41,066,417	22,514,603	101,950,389	18,699,194	186,096,762
1901	14,963,676	49,356,741	25,527,846	8,874,860	132,060,667	18,650,979	215,990,073
1902	10,715,151	70,591,274	29,591,274	7,572,452	154,856,102	17,759,203	230,072,516
1903	7,794,705	35,642,994	19,750,448	10,520,156	114,181,420	19,716,484	202,905,598
1904	10,985,988	29,013,743	29,121,763	15,418,537	44,230,169	16,999,432	120,727,613
1905	14,858,612	51,535,580	113,282,760	18,348,077	4,394,402	8,826,335	44,112,910
1906	13,026,904	43,793,519	38,142,103	22,175,846	34,973,291	13,919,048	97,609,007
1907	16,809,534	41,880,304	30,174,371	21,237,603	76,569,423	15,584,667	146,700,425
1908	22,920,480	41,019,991	28,444,415	25,510,643	100,371,057	13,927,247	163,043,669
1909	10,446,884	51,087,329	20,511,429	79,946,297	66,923,244	10,521,161	114,268,468
1910	10,589,254	29,860,667	26,779,188	125,507,022	46,679,876	9,040,987	87,364,318
1911	13,104,774	30,069,459	30,063,341	54,947,444	23,729,302	10,129,435	69,311,760
1912	12,190,663	53,262,796	39,446,571	79,594,034	30,160,212	11,006,487	79,689,404

TABLE 187.—Exports of selected domestic agricultural products, 1851-1912—Continued.

Year ending June 30—	Hops.	Oils, vegetable—cottonseed oil.	Rice and rice bran, meal, and polish.	Sugar, raw and refined.	Wheat.	Wheat flour.	Wheat and wheat flour (converted to wheat).
<b>Average:</b>	<i>Pounds.</i>	<i>Gallons.</i>	<i>Pounds.</i>	<i>Pounds.</i>	<i>Bushels.</i>	<i>Barrels.</i>	<i>Bushels.</i>
1851-1855	975, 171	.....	55, 662, 440	6, 526, 357	3, 289, 391	2, 629, 904	16, 438, 909
1856-1860	658, 630	.....	70, 552, 800	6, 567, 069	7, 761, 715	3, 155, 654	23, 539, 985
1861-1865	6, 416, 500	.....	10, 517, 760	3, 417, 976	27, 661, 526	3, 958, 898	47, 456, 016
1866-1870	5, 901, 883	.....	2, 210, 360	4, 480, 712	16, 361, 673	2, 290, 957	27, 816, 458
1871-1875	2, 262, 879	.....	392, 515	10, 537, 646	44, 803, 875	3, 359, 537	61, 601, 560
1876-1880	10, 485, 841	3, 865, 830	660, 350	47, 640, 615	88, 682, 085	4, 573, 529	110, 948, 586
1881-1885	8, 649, 436	2, 908, 694	251, 381	78, 694, 439	101, 445, 167	5, 573, 508	140, 026, 953
1886-1890	8, 170, 063	6, 168, 192	2, 851, 589	86, 273, 041	65, 264, 463	10, 653, 556	113, 205, 463
1891-1895	13, 540, 832	14, 094, 110	7, 960, 815	33, 805, 539	98, 810, 268	15, 057, 967	166, 571, 122
1896-1900	15, 827, 630	36, 881, 025	16, 307, 880	11, 319, 197	105, 965, 313	16, 345, 047	179, 518, 025
1901-1905	11, 863, 626	39, 718, 381	43, 454, 818	12, 146, 816	89, 944, 552	16, 390, 487	163, 701, 742
1906-1910	14, 758, 611	41, 528, 362	28, 810, 301	54, 875, 482	65, 103, 378	12, 598, 622	121, 797, 177

TABLE 188.—Imports of selected agricultural products, 1851-1912.

[Compiled from reports of Foreign Commerce and Navigation of the United States. Where figures are lacking, either there were no imports or they were not separately classified for publication. "Silk" includes, prior to 1881, only "Silk, raw or as reeled from the cocoon;" in 1881 and 1882 are included this item and "Silk waste"; after 1882, both these items and "Silk cocoons." From "Cocoa and chocolate" are omitted in 1860, 1861, and in 1872 to 1881, small quantities of chocolate, the official returns for which were given only in value. "Jute and jute butts" includes in 1858 and 1859 an unknown quantity of "Sisal grass, coir, etc.," and in 1865-1868 an unknown quantity of "Hemp." Cattle hides are included in "Hides and skins other than cattle and goat" in 1895-1897. Olive oil for table use includes in 1862-1864 and 1885-1905 all olive oil. Sisal grass includes in 1884-1890 "Other vegetable substances." Hemp includes in 1885-1888 all substitutes for hemp.]

Year ending June 30—	Cheese.	Silk.	Wool.	Almonds.	Argols or wine lees.	Cocoa and chocolate, total.	Coffee.
	<i>Pounds.</i>	<i>Pounds.</i>	<i>Pounds.</i>	<i>Pounds.</i>	<i>Pounds.</i>	<i>Pounds.</i>	<i>Pounds.</i>
1851	603, 398	.....	32, 607, 315	2, 854, 804	.....	2, 198, 609	152, 519, 743
1852	514, 337	.....	18, 343, 218	1, 564, 703	.....	1, 372, 341	193, 906, 353
1853	874, 949	.....	21, 616, 035	4, 721, 250	.....	3, 453, 288	199, 408, 045
1854	969, 417	.....	20, 282, 635	2, 187, 934	.....	3, 162, 072	162, 255, 993
1855	1, 526, 942	.....	18, 814, 402	3, 716, 251	.....	2, 427, 707	191, 478, 657
1856	1, 384, 272	.....	16, 280, 947	5, 113, 897	.....	2, 017, 471	235, 865, 268
1857	1, 400, 252	.....	17, 750, 156	2, 845, 594	.....	2, 044, 637	240, 676, 227
1858	1, 589, 066	.....	.....	2, 210, 941	.....	1, 810, 449	189, 211, 300
1859	1, 409, 420	.....	.....	5, 439, 210	.....	5, 067, 369	264, 436, 534
1860	1, 401, 161	.....	.....	2, 873, 014	.....	3, 186, 721	202, 144, 733
1861	1, 090, 835	.....	.....	2, 886, 685	976, 072	3, 210, 291	184, 706, 655
1862	594, 822	.....	.....	918, 360	866, 404	3, 541, 364	122, 799, 311
1863	545, 966	.....	.....	1, 726, 281	1, 007, 585	2, 055, 198	80, 461, 614
1864	836, 127	407, 935	.....	3, 964, 875	1, 597, 790	2, 940, 571	131, 622, 782
1865	985, 362	.....	.....	1, 229, 112	1, 297, 962	1, 177, 594	106, 643, 062
1866	.....	567, 904	.....	4, 571, 687	2, 004, 996	2, 550, 978	181, 413, 192
1867	1, 738, 657	491, 983	.....	4, 315, 819	1, 876, 731	3, 387, 890	187, 236, 580
1868	2, 997, 944	512, 449	.....	1, 461, 007	1, 822, 498	3, 211, 976	248, 983, 900
1869	.....	720, 045	39, 275, 926	.....	2, 346, 678	3, 826, 905	254, 160, 993
1870	.....	583, 589	.....	.....	2, 591, 472	3, 640, 845	235, 256, 574
1871	.....	1, 100, 281	.....	.....	3, 164, 965	3, 445, 453	317, 992, 048
1872	.....	1, 063, 809	.....	.....	4, 942, 601	4, 917, 809	298, 805, 946
1873	.....	1, 159, 420	85, 496, 049	.....	4, 007, 779	5, 734, 356	293, 297, 271
1874	.....	794, 837	42, 939, 541	.....	3, 246, 376	3, 661, 992	285, 171, 512
1875	.....	1, 101, 681	54, 901, 760	.....	5, 512, 808	5, 257, 255	317, 970, 665
1876	.....	1, 354, 991	44, 642, 836	.....	7, 047, 802	4, 715, 406	339, 789, 246
1877	.....	1, 186, 170	42, 171, 192	.....	9, 025, 542	4, 694, 215	331, 639, 723
1878	.....	1, 182, 750	48, 449, 079	.....	4, 007, 909	4, 780, 339	309, 882, 540
1879	.....	1, 889, 776	39, 005, 155	.....	14, 011, 764	5, 827, 027	377, 848, 473
1880	.....	2, 562, 236	128, 131, 747	.....	14, 445, 534	7, 508, 130	446, 850, 727

TABLE 188.—Imports of selected agricultural products, 1851-1912—Continued.

Year ending June 30—	Cheese.	Silk.	Wool.	Almonds.	Argols or wine lees.	Cocoa and chocolate, total.	Coffee.
	<i>Pounds.</i>	<i>Pounds.</i>	<i>Pounds.</i>	<i>Pounds.</i>	<i>Pounds.</i>	<i>Pounds.</i>	<i>Pounds.</i>
1881.....	2,790,413	55,964,236	14,275,530	8,767,728	11,091,123	455,189,534	
1882.....	3,221,269	67,861,744	18,320,366	11,091,123	9,437,791	459,922,768	
1883.....	4,731,106	70,575,478	16,112,427	9,437,791	12,739,871	515,878,515	
1884.....	6,243,014	4,284,888	78,350,651	3,828,104	19,591,039	534,785,542	
1885.....	6,247,560	4,308,908	70,596,170	4,732,269	17,694,336	572,599,552	
1886.....	6,309,124	6,818,060	129,084,958	5,822,733	16,041,666	564,707,533	
1887.....	6,592,192	6,028,091	114,038,030	5,482,363	22,024,768	526,109,170	
1888.....	8,750,185	6,370,322	113,558,753	5,747,957	17,226,491	423,645,794	
1889.....	8,207,026	6,645,124	126,487,729	5,545,400	21,429,034	578,397,454	
1890.....	9,263,573	7,510,440	105,431,285	5,715,858	24,908,454	499,159,120	
1891.....	8,863,640	6,266,629	129,303,648	6,812,061	21,579,102	519,528,432	
1892.....	8,305,288	8,834,049	148,670,652	7,629,392	24,813,171	640,210,788	
1893.....	10,195,924	8,497,477	172,433,838	6,679,147	28,770,810	563,469,068	
1894.....	8,742,551	5,902,485	55,152,585	7,436,784	22,373,180	550,934,337	
1895.....	10,276,293	9,316,460	206,033,906	7,903,375	27,911,122	652,208,975	
1896.....	10,728,397	9,363,987	230,911,473	7,789,681	28,481,665	580,597,915	
1897.....	12,319,122	7,993,444	350,852,026	9,644,338	23,457,576	737,645,670	
1898.....	10,012,188	12,087,551	132,795,202	5,746,362	19,202,629	870,514,455	
1899.....	11,826,175	11,250,383	76,736,209	9,957,427	23,300,762	831,827,063	
1900.....	13,455,990	13,073,718	155,928,455	6,317,633	27,339,489	872,991,911	
1901.....	15,329,099	10,405,555	103,583,505	5,140,232	28,598,781	854,871,310	
1902.....	17,067,714	14,234,826	166,576,966	9,868,982	29,276,148	1,091,004,252	
1903.....	20,671,384	15,270,859	177,137,796	8,142,164	29,966,557	915,086,380	
1904.....	22,707,103	16,722,709	173,742,834	9,838,852	24,571,730	995,043,284	
1905.....	23,095,705	22,357,307	249,135,746	11,745,081	26,281,931	1,047,792,984	
1906.....	27,286,866	17,352,021	201,688,668	15,009,326	28,140,835	851,668,933	
1907.....	33,848,766	18,743,904	203,847,545	14,233,613	30,540,893	985,321,473	
1908.....	32,530,830	16,662,132	125,980,524	17,144,968	26,738,834	890,640,677	
1909.....	35,548,143	25,187,957	266,409,304	11,029,421	32,115,646	1,049,868,788	
1910.....	40,817,524	23,457,223	263,928,232	18,556,356	28,182,956	871,469,516	
1911.....	45,568,797	26,666,091	137,647,641	15,522,712	29,175,133	875,366,797	
1912.....	46,542,007	26,584,962	193,400,713	17,221,458	23,661,078	885,201,247	
<b>Average:</b>							
1851-1855.....	897,809	.....	22,332,721	3,008,988	.....	179,913,758	
1856-1860.....	1,436,834	.....	.....	3,696,531	.....	226,466,812	
1861-1865.....	810,622	.....	.....	2,145,065	.....	125,210,635	
1866-1870.....	.....	575,194	.....	.....	1,149,163	221,410,248	
1871-1875.....	.....	1,044,006	.....	.....	2,128,535	302,647,488	
1876-1880.....	.....	1,635,185	60,480,002	.....	4,174,906	361,202,142	
1881-1885.....	.....	3,867,317	68,669,656	.....	.....	507,675,182	
1886-1890.....	7,824,420	6,674,407	117,720,151	5,662,862	.....	518,403,814	
1891-1895.....	9,276,799	7,763,420	142,318,926	7,292,152	.....	555,270,320	
1896-1900.....	11,668,374	10,753,897	189,444,673	7,891,088	24,356,424	761,715,403	
1901-1905.....	19,774,201	15,798,251	174,035,369	8,947,062	27,739,029	980,759,642	
1906-1910.....	34,006,426	20,280,647	212,370,855	15,194,737	29,143,833	929,793,749	
<b>Year ending June 30—</b>	<b>Flax.</b>	<b>Hemp.</b>	<b>Hops.</b>	<b>Jute and jute butts.</b>	<b>Licorice root.</b>	<b>Manila.</b>	<b>Molasses.</b>
	<i>Long tons.</i>	<i>Long tons.</i>	<i>Pounds.</i>	<i>Long tons.</i>	<i>Pounds.</i>	<i>Long tons.</i>	<i>Gallons.</i>
1851.....	1,059	1,876	.....	1,919	.....	9,917	36,376,772
1852.....	1,412	1,341	.....	2,012	.....	8,469	32,795,610
1853.....	678	2,621	.....	1,269	.....	12,510	31,886,100
1854.....	1,160	2,632	.....	4,368	.....	10,510	27,759,463
1855.....	1,454	961	.....	4,665	607,596	14,254	26,385,593
1856.....	1,011	317	.....	3,908	401,277	14,678	23,617,674
1857.....	1,149	3,082	.....	5,589	1,099,073	17,668	32,705,844
1858.....	.....	2,314	.....	21,586	668,786	.....	24,566,367
1859.....	.....	3,378	.....	22,538	993,161	.....	32,818,140
1860.....	.....	2,274	.....	23,279	2,561,964	.....	30,922,633
1861.....	.....	2,211	.....	13,203	1,539,882	6,366	29,941,397
1862.....	693	2,218	.....	2,004	460,632	10,329	25,157,230
1863.....	1,594	732	.....	2,582	1,173,034	13,961	30,854,264
1864.....	1,650	1,195	.....	2,498	4,715,628	16,735	33,571,230
1865.....	.....	1,627	3,837	2,990	793,197	13,948	36,445,906

TABLE 188.—Imports of selected agricultural products, 1851-1912—Continued.

Year ending June 30—	Flax.	Hemp.	Hops.	Jute and jute butts.	Licorice root.	Manila.	Molasses.
	<i>Long tons.</i>	<i>Long tons.</i>	<i>Pounds.</i>	<i>Long tons.</i>	<i>Pounds.</i>	<i>Long tons.</i>	<i>Gallons.</i>
1866.....			1,696,681	5,980	2,296,970	22,856	45,285,983
1867.....	1,571	3,193	865,016	7,809	3,034,255	15,273	56,123,079
1868.....			3,585,843	3,690	2,183,376	17,390	56,408,435
1869.....	1,953	18,731		17,549			53,304,030
1870.....	1,927	22,557		19,049			56,373,537
1871.....	3,672	20,805		26,450			44,401,359
1872.....	5,274	27,613		41,851			45,214,403
1873.....	4,171	20,573		63,329			43,533,909
1874.....	3,426	24,325		36,991			47,189,837
1875.....	4,322	23,063		43,402			49,112,255
1876.....	3,659	17,979		60,368			39,026,200
1877.....	4,498	17,128		50,793			45,214,825
1878.....	4,045	20,503		40,997			27,577,542
1879.....	2,935	17,711		69,590			38,460,347
1880.....	4,378	24,902		82,471			38,120,880
1881.....	5,446	32,044	497,243	68,631			28,708,221
1882.....	5,563	36,679	955,854	84,186			37,268,830
1883.....	5,748	29,063	2,122,589	125,318			33,228,276
1884.....	5,086	25,925	701,104	64,389	39,056,653		34,128,640
1885.....	6,435	32,463	1,642,086	98,343	26,406,008		31,392,893
1886.....							
1887.....	5,557	28,655	2,672,762	83,054	58,531,952		39,079,808
1888.....	7,140	32,739	18,538,049	88,514	79,603,835		38,007,700
1889.....	5,691	47,947	5,585,033	115,163	49,167,173		35,582,539
1890.....	7,896	55,835	4,176,158	89,655	57,068,600		27,024,551
1891.....	8,048	36,591	6,539,516	90,399	55,229,348		31,497,243
1892.....							
1893.....	6,331	11,484	4,019,603	141,704	55,307,911	35,331	20,604,463
1894.....	7,812	5,187	2,506,224	88,624	98,659,583	44,574	32,448,209
1895.....	6,696	4,817	2,691,244	82,231	93,002,250	59,439	15,490,679
1896.....	4,352	1,635	828,022	50,037	70,158,301	35,233	19,670,663
1897.....	7,233	6,954	3,133,664	110,671	83,281,275	50,278	15,075,879
1898.....							
1899.....	7,833	8,450	2,772,045	88,992	87,123,461	47,244	4,687,664
1900.....	9,190	5,120	3,017,821	68,550	62,370,337	46,260	24,630,935
1901.....	5,529	4,017	2,375,922	112,306	70,136,591	50,270	3,603,547
1902.....	6,474	3,941	1,319,319	83,161	98,432,319	53,195	5,821,556
1903.....	6,967	3,400	2,589,725	102,693	106,333,199	42,624	7,025,068
1904.....							
1905.....	6,878	4,057	2,606,708	103,140	100,105,654	43,735	11,453,156
1906.....	7,772	6,054	2,805,293	128,963	109,077,323	56,453	14,391,215
1907.....	8,155	4,919	6,012,510	79,703	88,580,611	61,648	17,240,399
1908.....	10,123	5,871	2,758,163	96,735	89,463,182	65,666	18,828,530
1909.....	8,089	3,987	4,339,379	98,215	108,443,892	61,592	19,477,885
1910.....							
1911.....	8,729	5,317	10,113,989	103,945	102,151,969	58,738	16,021,076
1912.....	8,656	8,718	6,211,893	104,489	66,115,863	54,513	24,630,935
Average:							
1851-1855.....	1,153	1,886		2,847		11,132	31,040,708
1856-1860.....		2,273		15,380	1,144,852		28,945,131
1861-1865.....		1,597		4,657	1,736,475	12,268	31,194,015
1866-1870.....				10,815			53,499,013
1871-1875.....	4,173	23,276		42,405			45,890,353
1876-1880.....	3,903	19,645		60,844			34,702,559
1881-1885.....	5,656	31,235	1,183,775	88,173			32,945,372
1886-1890.....	6,866	40,353	7,502,304	93,157	59,920,182		34,238,368
1891-1895.....	6,485	6,015	2,635,751	94,653	80,081,864	44,971	18,657,979
1896-1900.....	7,199	4,986	2,414,966	91,140	84,879,181	47,919	4,968,061
1901-1905.....	8,203	4,978	3,704,411	101,351	99,134,132	57,813	16,278,237
1906-1910.....	9,909	6,376	7,081,256	108,161	91,514,765	64,175	22,583,926

TABLE 188.—Imports of selected agricultural products, 1851–1912—Continued.

Year ending June 30—	Olive oil, for table use.	Opium, crude.	Potatoes.	Rice, and rice flour, rice meal, and broken rice.	Sisal grass.	Sugar, raw and refined.	Tea.
	Gallons.	Pounds.	Bushels.	Pounds.	Longtons.	Pounds.	Pounds.
1851		40,885	299,132			380,402,289	17,461,114
1852		42,123	322,223			457,511,093	29,437,206
1853		131,370	353,082			464,392,286	22,721,745
1854		108,178	306,187			455,928,585	24,417,712
1855		111,229	516,241			473,809,847	25,333,097
1856		157,814	535,320			545,226,430	22,889,850
1857		131,154	693,611			776,984,262	20,367,824
1858		135,915				519,200,387	32,965,021
1859		71,839				655,846,362	29,268,757
1860		119,525				694,838,197	31,696,657
1861		109,536	753,511			809,749,958	26,419,956
1862	292,024	194,844	837,223	56,961,317	287	557,139,529	24,795,983
1863	173,561	62,618	327,315	61,196,740	567	522,122,085	29,761,037
1864	79,457	93,114	4,497	99,691,447	1,021	632,230,247	37,229,176
1865	87,860	110,790	10,955	60,407,756	332	651,638,818	19,568,318
1866	256,833	181,585	78,194	76,209,397	870	1,000,055,024	42,992,738
1867	124,497	135,305	198,265	44,782,223	864	849,054,006	39,892,658
1868	161,313	183,263	209,555	59,140,707	1,661	1,121,189,415	37,843,612
1869	176,887	157,182	138,470	53,065,191		1,247,833,430	43,754,354
1870	159,397	254,609	75,336	43,123,939		1,196,773,569	47,408,481
1871	142,243	315,121	458,758	64,655,827		1,277,473,653	51,364,919
1872	196,364	416,864	96,259	74,642,631		1,509,185,674	63,811,036
1873	182,818	319,134	346,840	83,755,225		1,568,304,592	64,815,103
1874	139,241	395,909	549,073	73,257,716		1,701,297,869	55,811,605
1875	176,119	305,136	188,757	59,414,749		1,797,509,990	64,856,899
1876	178,232	388,311	92,148	71,561,852		1,493,977,472	62,887,153
1877	194,069	349,223	3,205,555	64,013,064		1,654,556,831	58,347,112
1878	217,017	430,950	528,584	47,489,878		1,537,451,934	65,366,704
1879	192,326	405,957	2,624,149	75,824,923		1,834,365,836	60,194,673
1880	264,762	533,451	721,868	57,006,255		1,829,301,684	72,162,936
1881	224,362	318,700	2,170,372	68,739,409		1,946,865,165	81,843,988
1882	264,838	370,249	8,789,860	79,412,841		1,990,449,609	78,769,060
1883	257,375	457,499	2,362,362	96,673,080		2,137,819,123	73,479,164
1884		326,539	425,408	106,630,523	32,082	2,756,416,896	67,665,910
1885	493,928	334,169	658,633	119,074,577	36,897	2,717,884,653	72,104,956
1886	634,354	471,276	1,937,416	97,562,353	35,300	2,946,865,765	81,887,998
1887	744,766	568,263	1,432,490	103,950,359	36,355	3,136,443,240	89,831,221
1888	654,162	477,020	8,259,538	155,623,501	36,401	2,700,284,282	84,627,870
1889	893,338	391,563	883,380	186,376,560	38,542	2,762,202,967	79,575,984
1890	893,984	473,095	3,415,578	124,029,171	50,858	2,934,011,560	83,886,829
1891	605,509	466,554	5,401,912	214,363,582	39,213	3,483,477,222	83,453,339
1892	706,486	657,118	186,871	148,103,688	48,020	3,556,509,165	90,079,039
1893	686,852	615,957	4,317,021	147,483,828	54,431	3,766,445,347	89,061,287
1894	757,478	716,881	3,002,578	142,161,817	48,468	4,345,193,881	93,518,717
1895	775,046	358,455	1,341,533	219,564,320	47,596	3,574,510,454	97,253,458
1896	942,598	365,514	175,240	146,724,607	52,130	3,689,338,557	93,998,372
1897	928,567	1,072,914	246,178	197,816,134	63,266	4,918,905,733	113,347,175
1898	786,877	123,845	1,171,378	190,285,315	69,322	4,689,920,851	71,957,715
1899	930,042	513,499	530,420	204,177,293	71,898	3,980,250,769	74,089,899
1900	967,702	544,938	155,861	116,679,891	76,921	4,018,086,530	84,845,107
1901	983,059	583,208	371,911	117,199,710	70,076	3,979,005,840	89,806,453
1902	1,339,097	534,189	7,656,162	157,658,894	89,583	3,031,915,875	76,579,125
1903	1,494,132	516,570	358,505	169,656,284	87,025	4,216,108,106	108,574,905
1904	1,713,590	573,055	3,166,581	154,221,772	109,214	3,700,623,613	112,905,541
1905	1,923,174	594,680	181,199	106,483,515	100,301	3,680,932,998	102,706,599
1906	2,447,131	469,387	1,948,160	166,547,957	98,037	3,979,331,430	93,621,750
1907	3,449,517	565,252	176,917	209,603,180	99,061	4,391,839,975	86,368,490
1908	3,799,112	285,845	493,952	212,783,392	103,994	3,371,997,112	94,149,564
1909	4,129,454	517,388	8,383,966	222,900,422	91,451	4,189,421,018	114,916,520
1910	3,702,210	449,239	353,208	225,400,545	99,966	4,094,545,936	85,626,370
1911	4,405,827	629,842	218,984	208,774,795	117,727	3,937,978,265	102,653,942
1912	4,836,515	399,837	13,734,695	190,063,331	114,467	4,104,618,393	101,406,816

TABLE 188.—Imports of selected agricultural products, 1851–1912—Continued.

Year ending June 30—	Olive oil, for table use.	Opium, crude.	Potatoes.	Rice, and rice flour, rice meal, and broken rice.	Sisal grass.	Sugar, raw and refined.	Tea.
<b>Average:</b>	<i>Gallons.</i>	<i>Pounds.</i>	<i>Bushels.</i>	<i>Pounds.</i>	<i>Long tons.</i>	<i>Pounds.</i>	<i>Pounds.</i>
1851-1855.....	.....	86, 757	359, 373	.....	.....	446, 408, 820	23, 874, 175
1856-1860.....	.....	123, 249	.....	.....	.....	638, 419, 128	27, 443, 622
1861-1865.....	.....	114, 180	386, 700	.....	.....	634, 576, 127	27, 554, 894
1866-1870.....	175, 745	182, 389	139, 964	55, 264, 291	.....	1, 082, 981, 089	42, 378, 369
1871-1875.....	167, 357	350, 433	327, 937	71, 145, 230	.....	1, 570, 754, 356	60, 131, 912
1876-1880.....	209, 281	421, 578	1, 434, 461	63, 179, 194	.....	1, 669, 930, 751	63, 791, 716
1881-1885.....	.....	361, 431	2, 881, 327	94, 106, 086	.....	2, 309, 887, 089	74, 772, 616
1886-1890.....	764, 121	476, 243	3, 185, 680	133, 508, 389	39, 491	2, 844, 564, 763	83, 961, 980
1891-1895.....	706, 274	548, 993	2, 849, 983	174, 335, 447	47, 546	3, 745, 227, 214	90, 673, 168
1893-1900.....	901, 157	524, 142	455, 815	171, 136, 648	66, 707	3, 900, 700, 488	87, 647, 654
1901-1905.....	1, 490, 610	560, 340	2, 346, 872	141, 044, 035	91, 240	3, 720, 917, 286	97, 914, 525
1906-1910.....	3, 505, 485	457, 422	2, 253, 241	207, 447, 099	98, 502	4, 005, 427, 094	94, 936, 369

Year ending June 30—	Beeswax.	Onions.	Plums and prunes.	Raisins.	Currants.	Dates.	Figs.
	<i>Pounds.</i>	<i>Bushels.</i>	<i>Pounds.</i>	<i>Pounds.</i>	<i>Pounds.</i>	<i>Pounds.</i>	<i>Pounds.</i>
1883.....	168, 879	.....	60, 600, 228	53, 702, 220	.....	.....	7, 945, 977
1884.....	48, 123	.....	57, 631, 820	38, 319, 787	.....	.....	7, 770, 178
1885.....	91, 754	.....	.....	.....	.....	.....	.....
1886.....	26, 546	.....	64, 995, 545	40, 387, 946	.....	.....	7, 223, 070
1887.....	10, 843	.....	92, 032, 625	40, 673, 288	.....	.....	8, 724, 583
1888.....	51, 702	.....	70, 626, 027	40, 476, 763	.....	.....	10, 058, 053
1889.....	75, 951	.....	46, 154, 825	35, 091, 139	.....	.....	10, 649, 409
1890.....	126, 319	.....	58, 093, 410	36, 914, 330	.....	.....	10, 284, 998
1891.....	379, 135	.....	34, 281, 322	39, 572, 655	33, 128, 140	18, 239, 057	9, 201, 565
1892.....	271, 068	.....	10, 869, 797	20, 687, 640	36, 665, 828	17, 084, 557	8, 338, 759
1893.....	248, 000	.....	26, 414, 112	27, 543, 563	33, 166, 546	16, 211, 906	10, 503, 928
1894.....	318, 660	.....	9, 908, 122	13, 751, 050	52, 664, 843	12, 408, 192	7, 985, 959
1895.....	288, 001	.....	14, 352, 057	15, 921, 278	16, 450, 706	15, 186, 789	11, 855, 890
1896.....	273, 464	.....	483, 658	10, 826, 094	33, 040, 846	13, 680, 302	11, 900, 710
1897.....	174, 017	560, 138	710, 028	12, 650, 598	29, 265, 761	11, 847, 279	8, 940, 762
1898.....	272, 097	488, 853	303, 992	6, 593, 833	25, 186, 210	13, 561, 434	9, 628, 426
1899.....	452, 016	771, 960	600, 360	4, 933, 201	30, 849, 253	12, 943, 305	7, 284, 058
1900.....	213, 813	546, 798	443, 457	10, 309, 498	36, 251, 779	19, 902, 512	8, 812, 487
1901.....	213, 773	774, 042	745, 974	3, 860, 836	16, 049, 198	20, 013, 681	9, 933, 371
1902.....	408, 706	796, 316	522, 478	6, 683, 545	36, 238, 976	21, 681, 159	11, 087, 131
1903.....	488, 576	925, 599	633, 819	6, 715, 675	33, 878, 209	43, 814, 917	16, 482, 142
1904.....	425, 168	1, 171, 242	494, 105	6, 867, 617	38, 347, 649	21, 058, 164	13, 178, 061
1905.....	373, 569	856, 366	671, 604	4, 041, 689	31, 742, 919	19, 257, 250	13, 364, 107
1906.....	587, 617	872, 566	497, 494	12, 414, 855	37, 078, 311	22, 435, 672	17, 562, 358
1907.....	917, 088	1, 126, 114	323, 377	3, 967, 151	38, 392, 779	31, 270, 899	24, 346, 173
1908.....	671, 526	1, 275, 333	335, 089	9, 132, 353	38, 652, 656	24, 958, 343	18, 836, 574
1909.....	764, 937	574, 590	296, 123	5, 794, 320	32, 482, 111	21, 860, 218	15, 235, 513
1910.....	972, 145	1, 024, 226	.....	5, 042, 683	33, 326, 030	22, 693, 713	17, 362, 197
1911.....	902, 904	1, 514, 967	.....	2, 479, 220	33, 439, 565	29, 504, 592	23, 459, 728
1912.....	1, 076, 741	1, 436, 037	.....	3, 255, 861	33, 151, 396	25, 208, 248	18, 765, 408
<b>Average:</b>	.....	.....	.....	.....	.....	.....	.....
1886-1890.....	58, 272	.....	66, 380, 486	38, 708, 693	.....	.....	9, 387, 951
1891-1895.....	300, 973	.....	19, 165, 082	23, 495, 237	34, 415, 213	15, 826, 100	9, 577, 220
1896-1900.....	277, 081	.....	508, 299	9, 062, 645	30, 918, 770	14, 386, 966	9, 313, 289
1901-1905.....	381, 958	904, 713	613, 596	5, 633, 872	31, 251, 390	25, 165, 034	12, 809, 062
1906-1910.....	782, 663	974, 554	.....	7, 270, 272	35, 986, 377	24, 645, 569	18, 668, 563

TABLE 188.—Imports of selected agricultural products, 1851-1912—Continued.

Year ending June 30—	Hides and skins, other than furs.			Macaroni, vermicelli, and all similar prepara- tions.	Lemons.	Oranges.	Walnuts.
	Cattle.	Goat.	Other than cattle and goat.				
	<i>Pounds.</i>	<i>Pounds.</i>	<i>Pounds.</i>	<i>Pounds.</i>	<i>Pounds.</i>	<i>Pounds.</i>	<i>Pounds.</i>
1895.....	.....	54,240,492	172,335,253	.....	.....	.....	.....
1896.....	.....	46,747,029	163,650,982	.....	.....	.....	.....
1897.....	.....	49,868,020	156,232,824	.....	.....	.....	.....
1898.....	126,243,595	64,923,487	54,607,534	.....	.....	.....	.....
1899.....	130,396,020	69,728,945	66,965,785	.....	.....	.....	.....
1900.....	163,865,165	81,993,818	100,070,795	.....	160,198,056	68,618,938	.....
1901.....	129,174,624	73,745,596	77,989,617	.....	148,514,614	50,332,914	.....
1902.....	148,627,907	88,038,516	89,457,680	.....	164,075,309	52,742,476	.....
1903.....	131,644,325	85,114,070	102,340,303	28,787,821	152,004,213	56,872,070	12,362,567
1904.....	85,370,168	86,338,547	103,024,752	40,224,202	171,923,221	35,893,260	23,670,761
1905.....	113,177,357	97,803,571	126,893,934	53,441,080	139,084,321	28,880,575	21,684,104
1906.....	156,155,300	111,079,391	158,045,419	77,926,029	138,717,252	31,134,341	24,917,028
1907.....	134,671,020	101,201,596	135,111,199	87,720,730	157,859,906	21,267,346	32,597,692
1908.....	98,353,249	63,640,758	120,770,918	97,233,708	178,490,003	18,397,429	28,887,110
1909.....	192,252,083	104,048,244	148,253,998	85,114,003	135,183,550	8,435,873	26,157,703
1910.....	318,003,538	115,844,758	174,770,732	113,772,801	160,214,785	4,676,118	33,641,466
1911.....	150,127,796	86,913,842	137,849,757	114,779,116	134,968,924	7,672,186	33,619,434
1912.....	251,012,513	95,340,703	191,414,832	108,231,028	145,639,396	7,628,662	37,213,674
Average:							
1896-1900.....	.....	62,653,260	108,305,584	.....	155,120,336	44,944,259	.....
1901-1905.....	121,598,876	96,208,060	99,941,257	.....	154,093,099	16,782,221	29,240,180
1906-1910.....	179,887,038	99,162,949	147,390,453	92,353,454	.....	.....	.....

TABLE 189.—Foreign trade of the United States in forest products, 1851-1912.

[Compiled from reports of Foreign Commerce and Navigation of the United States. All values are gold.]

Year ending June 30—	Exports.		Imports.	Excess of exports (+) or of imports (-).
	Domestic.	Foreign.		
1851.....	\$4,188,635	\$566,554	\$1,332,522	+\$3,422,667
1852.....	4,400,741	411,166	1,133,785	+ 3,678,122
1853.....	4,704,394	341,566	1,244,991	+ 3,800,969
1854.....	8,636,443	470,483	1,881,492	+ 7,225,434
1855.....	8,879,743	1,320,670	5,400,736	+ 4,799,677
1856.....	7,474,074	926,299	6,620,505	+ 1,779,868
1857.....	10,411,894	1,164,280	6,419,320	+ 5,156,854
1858.....	10,579,417	1,295,768	6,631,396	+ 5,243,789
1859.....	11,396,163	747,621	6,488,908	+ 5,654,876
1860.....	10,299,959	846,929	8,086,735	+ 3,060,153
1861.....	7,286,605	756,112	7,084,695	+ 958,022
1862.....	6,468,911	808,273	5,982,091	+ 1,295,093
1863.....	6,544,788	872,515	7,849,625	- 432,322
1864.....	6,608,236	616,086	10,401,691	- 3,177,369
1865.....	7,629,020	1,109,049	6,688,145	+ 2,049,924
1866.....	9,579,561	584,459	11,635,299	- 1,471,279
1867.....	11,175,119	599,918	12,975,903	- 1,200,866
1868.....	11,956,584	674,786	12,586,964	+ 44,406
1869.....	11,885,488	361,480	14,326,334	- 2,079,366
1870.....	11,984,445	1,181,708	17,555,708	- 4,389,555
1871.....	11,874,850	635,847	16,617,972	- 4,107,275
1872.....	16,494,184	1,004,495	19,402,210	- 1,903,531
1873.....	19,578,615	774,909	24,452,286	- 4,098,762
1874.....	21,143,701	1,116,763	21,468,824	+ 791,640
1875.....	16,680,377	1,019,887	17,295,187	+ 405,077

TABLE 189.—Foreign trade of the United States in forest products, 1851-1912—Continued.

Year ending June 30—	Exports.		Imports.	Excess exports (+) or of imports (-).
	Domestic.	Foreign.		
1876.....	\$15,636,980	\$883,254	\$16,023,785	+ \$496,449
1877.....	18,312,446	532,547	15,386,709	+ 3,458,284
1878.....	17,180,147	705,941	16,344,201	+ 1,541,887
1879.....	16,023,005	557,434	18,745,076	- 2,164,637
1880.....	17,056,870	614,399	27,847,871	-10,176,602
1881.....	19,324,096	352,249	31,707,280	-12,030,935
1882.....	25,590,254	1,321,446	36,962,880	-10,061,180
1883.....	28,645,199	2,137,165	37,623,551	- 6,841,187
1884.....	26,222,959	1,450,032	35,931,961	- 8,258,979
1885.....	22,014,839	1,125,404	28,702,940	- 5,562,697
1886.....	21,061,708	1,052,083	32,042,431	- 9,928,640
1887.....	21,126,152	1,568,996	34,704,566	-12,009,418
1888.....	23,991,092	1,319,270	39,861,356	-14,550,994
1889.....	26,997,602	1,767,853	36,887,715	- 8,122,260
1890.....	29,473,084	1,337,677	40,010,518	- 9,199,757
1891.....	28,715,713	1,220,002	46,772,282	-16,836,567
1892.....	27,957,928	1,542,639	47,052,892	-17,552,325
1893.....	28,127,281	1,178,837	49,720,275	-20,414,157
1894.....	28,001,461	1,973,803	39,683,781	- 9,708,517
1895.....	28,576,680	1,277,705	43,302,134	-13,447,749
1896.....	33,718,790	2,563,550	45,696,324	- 9,413,984
1897.....	40,490,428	3,242,262	44,791,463	- 1,058,773
1898.....	38,439,418	2,582,082	45,751,938	- 4,730,438
1899.....	42,828,732	3,011,832	53,314,266	- 7,473,702
1900.....	52,676,575	3,981,002	60,633,078	- 3,975,501
1901.....	55,369,161	3,599,192	57,143,650	+ 1,824,703
1902.....	48,928,764	3,609,071	59,137,049	- 6,649,214
1903.....	58,734,016	2,865,325	71,478,022	- 9,878,681
1904.....	70,085,739	4,177,352	79,619,296	- 5,356,155
1905.....	63,199,348	3,790,097	92,680,555	-26,691,110
1906.....	76,975,431	4,809,261	96,462,364	-14,677,672
1907.....	92,948,705	5,500,331	122,420,776	-23,971,740
1908.....	90,362,073	4,570,397	97,733,092	- 2,800,622
1909.....	72,442,454	4,982,810	123,920,126	-46,494,862
1910.....	85,030,230	9,801,881	178,871,797	-84,039,686
1911.....	103,038,892	7,586,854	162,311,565	-51,685,819
1912.....	108,122,254	6,413,343	172,523,465	-57,987,868
<b>Average:</b>				
1851-1855.....	6,161,991	622,088	2,198,705	+ 4,585,374
1856-1860.....	10,032,301	996,179	6,849,373	+ 4,179,107
1861-1865.....	6,907,512	832,407	7,601,249	+ 138,670
1866-1870.....	11,316,239	680,470	13,816,042	- 1,819,333
1871-1875.....	17,154,345	910,380	19,847,296	- 1,782,571
1876-1880.....	16,841,890	658,715	18,869,528	- 1,368,923
1881-1885.....	24,357,469	1,277,259	34,185,722	- 8,550,994
1886-1890.....	24,529,928	1,409,176	36,701,317	-10,762,213
1891-1895.....	28,275,813	1,438,597	45,306,273	-15,591,863
1896-1900.....	41,630,789	3,076,146	50,037,414	- 5,330,479
1901-1905.....	59,263,416	3,608,207	72,021,714	- 9,150,091
1906-1910.....	83,551,779	5,932,936	123,881,631	-34,396,916



TABLE 190.—Exports of selected domestic forest products, 1851-1912.

[Compiled from reports of Foreign Commerce and Navigation of the United States. Where figures are lacking, either there were no exports or they were not separately classified for publication.]

Year ending June 30—	Lumber.			Rosin.	Spirits of turpentine.	Timber.	
	Boards, deals, and planks. <sup>1</sup>	Shooks, other than box.	Staves.			Hewn.	Sawed.
	<i>M feet.</i>	<i>Number.</i>	<i>Number.</i>			<i>Barrels.</i>	<i>Gallons.</i>
1851.....	100,604			387,220	363,828		
1852.....	100,695			449,194	358,658		
1853.....	78,599			454,715	634,371		
1854.....	197,154			601,280	1,669,523		
1855.....	144,718			731,060	2,339,138		
1856.....	126,330			524,799	1,844,560		
1857.....	309,165			641,517	1,522,177		
1858.....	217,861			574,573	2,457,235		
1859.....	197,099			798,083	2,682,230		
1860.....	170,922			770,652	4,072,023		
1861.....	132,332			536,207	2,941,855		
1862.....	129,243			65,441	43,507		
1863.....	135,901			17,025	58,565		
1864.....	132,298	1,019,340		2,418	32,548		
1865.....	172,644	1,043,797		11,232	51,863		
1866.....	120,013			250,452	349,325		
1867.....	131,666			334,104	1,513,225		
1868.....	131,873			443,501	3,068,629		
1869.....	134,370			585,989	3,184,955		
1870.....	140,863			583,316	3,246,697	7,115,975	
1871.....	154,830			511,959	2,453,554	7,115,007	
1872.....	176,872			692,728	4,495,441	12,594,738	
1873.....	236,557			845,162	5,114,653	14,154,244	
1874.....	228,481			929,342		25,209,048	
1875.....	213,974			937,527	5,599,624	13,553,714	
1876.....	252,407			824,256		21,786,414	
1877.....	321,530				6,796,927	20,640,259	
1878.....	313,143			1,042,183	7,633,568	18,361,915	
1879.....	275,102			1,112,816	7,575,556	13,255,241	
1880.....	285,194			1,040,345	7,091,200	16,365,346	
1881.....	320,602			1,023,710	6,595,528	22,961,618	
1882.....	407,455			1,156,012	8,136,493	24,491,354	
1883.....	499,406			1,347,256	9,867,344	19,913,220	
1884.....	414,920	1,275,450		1,545,211	11,300,729	10,615,065	201,257
1885.....	412,424	1,281,571		1,269,304	8,987,226	8,411,066	153,248
1886.....	435,608	1,098,347		1,131,560	8,217,678	5,077,612	193,344
1887.....	424,760	902,269		1,365,012	10,209,883	4,260,639	167,609
1888.....	436,718	668,972		1,492,314	10,585,942	5,813,175	187,780
1889.....	571,075	543,597		1,420,218	9,681,759	6,301,065	252,996
1890.....	612,814	534,190		1,601,377	11,248,920	8,732,761	270,984
1891.....	613,406	316,242		1,790,251	12,243,621	6,900,073	214,612
1892.....	592,506	412,308		1,950,214	13,176,470	6,736,446	235,550
1893.....	629,355	385,863		2,059,407	13,415,459	7,836,921	214,198
1894.....	574,920	383,706		1,987,128	12,618,407	4,082,709	237,830
1895.....	588,781	352,928		1,862,394	14,652,738	6,039,539	297,663
1896.....	694,799	643,099		2,172,991	17,431,566	5,616,476	332,934
1897.....	876,689	695,858		2,429,116	17,302,823	6,406,824	391,291
1898.....	700,659	544,079	54,142,759	2,206,203	18,351,140	5,489,714	338,575
1899.....	970,170	616,380	44,382,689	2,563,229	17,761,533	4,796,658	406,448
1900.....	1,046,758	773,019	49,011,533	2,369,118	18,090,582	4,416,741	473,542
1901.....	1,101,155	714,651	47,363,262	2,820,815	20,240,851	4,624,698	533,920
1902.....	942,814	788,241	46,998,512	2,535,962	19,177,788	6,406,439	412,750
1903.....	1,065,771	566,205	55,879,010	2,396,498	16,378,787	3,291,498	530,659
1904.....	1,426,784	533,182	47,420,095	2,585,108	17,202,808	3,788,740	558,690
1905.....	1,283,406	872,192	48,286,285	2,310,275	15,894,813	3,856,623	486,411
1906.....	1,343,607	1,066,253	57,586,378	2,438,556	15,981,253	3,517,046	552,548
1907.....	1,623,964	895,858	51,120,171	2,560,966	15,854,676	3,278,110	600,865
1908.....	1,548,130	900,812	61,606,949	2,712,732	19,532,583	4,883,506	463,440
1909.....	1,357,822	977,376	52,583,016	2,170,177	17,502,028	2,950,528	383,309
1910.....	1,684,489	928,197	49,783,771	2,144,318	15,587,737	3,245,196	451,721

<sup>1</sup> Including "Joists and scantling," prior to 1884.

TABLE 190.—Exports of selected domestic forest products, 1851-1912—Continued.

Year ending June 30—	Lumber.			Rosin.	Spirits of turpentine.	Timber.	
	Boards, deals, and planks.	Shooks, other than box.	Staves.			Hewn.	Sawed.
1911.....	2,031,608	1,019,411	65,725,595	2,189,607	14,817,751	2,673,887	499,547
1912.....	2,306,680	1,161,591	64,162,599	2,474,460	19,599,241	31,067	406,954
Average:							
1851-1855.....	124,354			524,694	1,073,104		
1856-1860.....	204,275			661,925	2,515,645		
1861-1865.....	140,484			126,465	625,668		
1866-1870.....	131,757			439,472	2,272,566		
1871-1875.....	202,143			783,344		14,525,350	
1876-1880.....	289,475					18,081,835	
1881-1885.....	410,961			1,268,299	8,977,464	17,278,465	
1886-1890.....	496,195	749,475		1,402,096	9,988,836	6,037,050	214,543
1891-1895.....	599,812	370,209		1,929,879	13,221,339	6,319,138	239,977
1896-1900.....	875,815	654,487		2,348,131	17,787,529	5,345,283	388,558
1901-1905.....	1,164,118	694,894	49,189,433	2,529,732	17,779,009	4,190,000	504,486
1906-1910.....	1,511,602	935,197	54,554,057	2,405,350	16,891,655	3,574,877	490,377

TABLE 191.—Imports of selected forest products, 1851-1912.

[Compiled from reports of Foreign Commerce and Navigation of the United States. Where figures are lacking, either there were no imports or they were not separately classified for publication.]

Year ending June 30—	Camphor, crude.	India rubber.	Rubber gums, total.	Lumber.		Shellac.	Wood pulp.
				Boards, deals, planks, and other sawed.	Shingles.		
1851.....	176,226						
1852.....	189,316						
1853.....	109,908						
1854.....	233,496						
1855.....	193,909						
1856.....	341,972						
1857.....	389,568						
1858.....	706,999						
1859.....	612,263						
1860.....	49,047						
1861.....	44,734						
1862.....	298,097	2,125,561	2,458,821			131,974	
1863.....	221,280	5,104,650	5,128,026			615,036	
1864.....	517,570			333		789,510	
1865.....	177,756					531,081	
1866.....	718,953		136,855	108,439		1,103,777	
1867.....	432,075		142,262	413,375		784,365	
1868.....	2,005	8,438,019	8,438,019	255,843		548,227	
1869.....			7,813,134				
1870.....			9,624,098				
1871.....			11,031,939	725,994			
1872.....			11,803,437	714,731	102,904		
1873.....	1,117,930		14,536,978	818,302	108,448		
1874.....	780,737		14,191,320	562,395	109,245		
1875.....	947,191		12,035,909	393,786	82,110		
1876.....	322,972		10,589,297	333,996	38,279		
1877.....	1,022,565		13,821,109	316,271	34,190		
1878.....	1,117,290		12,512,203	327,298	47,532		
1879.....	982,580		14,878,584	355,304	48,710		
1880.....	2,445,471		16,826,099	515,343	59,402		

<sup>1</sup> Gutta-percha only.

TABLE 191.—Imports of selected forest products, 1851-1912—Continued.

Year ending June 30—	Camphor, crude.	India rubber.	Rubber gums, total.	Lumber.		Shellac.	Wood pulp.
				Boards, deals, planks, and other sawed.	Shingles.		
	<i>Pounds.</i>	<i>Pounds.</i>	<i>Pounds.</i>	<i>M feet.</i>	<i>M.</i>	<i>Pounds.</i>	<i>Long tons.</i>
1881.....	2,010,165		20,015,176	575,320	87,135		
1882.....	2,076,192		22,712,862	612,364	99,264		589
1883.....	2,312,166		21,646,320	572,099	104,657		
1884.....	2,047,732		24,574,025	600,762	86,219	2,865,753	7,491
1885.....	2,223,038		24,208,148	555,582	69,511	3,468,891	13,523
1886.....	1,133,913		29,263,632	547,832	79,150	4,396,431	10,139
1887.....	2,857,222		28,649,446	559,236	89,169	4,722,538	23,410
1888.....	2,779,719		36,628,351	608,743	161,715	4,206,850	35,133
1889.....	1,961,018		32,339,503	648,174	214,546	5,509,873	40,917
1890.....	2,055,287		33,842,374	660,327	194,168	4,739,465	43,478
1891.....	1,716,167	33,712,089	34,672,924	757,244	260,652	6,253,380	43,316
1892.....	1,955,787	39,976,205	40,284,444	663,253	363,027	6,310,266	41,118
1893.....	1,733,425	41,547,680	42,130,058	742,597	459,044	5,604,732	63,565
1894.....	1,323,932	33,757,783	34,256,546	514,619	378,632	4,868,681	35,587
1895.....	1,500,739	39,741,607	41,068,401	600,798	51,513	6,401,060	28,440
1896.....	945,629	36,774,460	40,618,314	786,209		6,056,957	45,143
1897.....	1,469,601	35,574,449	36,692,114	883,781		7,151,459	41,770
1898.....	2,047,234	46,055,497	46,691,974	353,215	435,421	6,984,395	29,846
1899.....	1,807,889	51,063,066	58,055,887	423,928	471,594	9,830,111	33,319
1900.....	1,789,580	49,377,138	58,506,569	680,226	541,040	10,621,451	82,441
1901.....	2,175,784	55,275,529	64,927,176	490,820	555,853	9,608,745	46,757
1902.....	1,831,058	50,413,481	67,790,069	665,603	707,614	9,064,789	67,416
1903.....	2,472,440	55,010,571	69,311,678	720,937	724,131	11,590,725	116,881
1904.....	2,819,673	59,015,551	74,327,584	589,232	770,373	10,933,413	144,796
1905.....	1,904,002	67,234,256	87,004,384	710,538	758,725	10,700,817	167,504
1906.....	1,668,744	57,844,345	81,109,451	949,717	900,856	15,780,090	157,224
1907.....	3,138,070	57,963,838	106,747,589	934,195	881,003	17,785,960	213,110
1908.....	2,814,299	62,233,160	85,809,625	791,288	988,081	13,361,932	237,514
1909.....	1,990,499	88,359,895	114,598,768	846,024	1,058,363	19,185,137	274,217
1910.....	3,026,648	101,044,681	154,620,629	1,054,416	762,798	29,402,182	378,322
1911.....	3,726,319	72,046,260	145,743,880	872,374	642,582	15,494,940	491,873
1912.....	2,154,646	110,210,173	175,965,538	905,275	514,657	18,745,771	477,508
Average:							
1851-1855.....	180,571						
1856-1860.....	419,970						
1861-1865.....	251,887						
1866-1870.....			5,190,874				
1871-1875.....			12,719,917	643,042			
1876-1880.....	1,178,176		13,725,458	369,642	45,623		
1881-1885.....	2,133,859		22,631,306	583,225	89,357		
1886-1890.....	2,157,432		32,144,661	604,862	147,750	4,715,031	30,615
1891-1895.....	1,646,010	37,747,073	38,482,475	655,702	302,574	5,887,624	42,405
1896-1900.....	1,611,987	43,768,922	48,112,972	625,472		8,128,875	46,504
1901-1905.....	2,240,591	57,389,878	72,672,178	635,426	703,339	10,379,698	108,671
1906-1910.....	2,527,652	77,289,184	108,577,212	915,128	918,220	19,103,060	252,077

<sup>1</sup> Including "Guayule gum," crude.

# INDEX.

	Page.
Abortion, infectious, of cattle, cause, control, etc., studies.....	47, 169-170
"Abraunsalz," discovery, value.....	523
Absinth importation and interstate transportation, prohibition.....	245
Accounts Division, review of work by Secretary.....	86-87
Adams Act fund, supervision of work by department.....	212-213
Administrative boards, Agriculture Department, personnel, duties, etc.....	243-247
<i>Agonoderus pallipes</i> , destruction by meadow larks.....	282
Agricultural agents, duties, location, etc.....	143-144
credit, benefit to farmer, etc.....	25-30, 447
economics, studies by Statistics Bureau.....	195-196
education, country schools, interest of produce dealer, etc.....	349-350
development in 16 years.....	147
experiment stations in the several States, post offices.....	352
explorations, progress.....	120
imports, remarks by Secretary.....	24
<i>See also</i> Imports.	
instruction in high schools, character, etc.....	472-481
problems, results of investigations by experiment stations.....	97-100
products, foreign trade of United States.....	22-24, 712-750
regions, percentage of agricultural high schools.....	476
schools, growth, extent, and number.....	101-102
Agriculture, animals injurious, control work.....	175
community work in high schools.....	477, 480-481
Department, administrative boards, personnel, duties, etc.....	243-247
appropriations, disbursements, etc., 1912.....	86
relation to crop production and cost of living.....	9
review by Secretary of 16 years' record.....	114-259
work for fiscal year 1912, review by Secretary.....	31-114
development in dry regions.....	124
graduate work, extension since 1897.....	214
high-school, influence.....	481-482
instruction in Bonham high school, Texas.....	478-479
high schools without State aid.....	475
laboratory and field work in high schools.....	477
officials in United States, principal National and State.....	541-542, 545
promotion by railways.....	711
public high schools, article by Dick J. Crosby.....	471-482
Secretary, duties outside of Department.....	247-248
report for 1912.....	9-259
semiarid sections, relation of dairying, etc., article by A. K. Risser.....	463-470
teaching in high schools, State aid, management, etc.....	472-475
Agronomy, instruction in high schools.....	477-479
Air drainage, mountain regions, advantages to fruit growers.....	314-318
homogeneous condition conducive to transmission of sound and light.....	382
upper, explorations by Weather Bureau.....	189-190
Alaska experiment stations, review of work by Secretary.....	103-104, 218-219
game protection, new regulations and officials.....	85
kelp groves, possibilities, outlook.....	534
National Forests, timber supplies to different industries.....	408
Alcohol, denatured, studies by Chemistry Bureau.....	201
manufacture from waste wood.....	200, 239
Aleutian Islands, atmospheric conditions, wireless reports to Weather Bureau.....	37
Alfalfa, extension of growing.....	121
improvement by pure-culture inoculation.....	139
introduction into Great Plains region, progress.....	467

	Page.
Alfalfa, relation to dry-land problem.....	10
weevil, destruction by meadow larks.....	282
investigations and control work.....	76, 81, 147, 148
Alfalfas, introduction of new varieties.....	119
Algæ, destruction in water, use of copper sulphate.....	139
Alkali lands, crops resistant to conditions.....	125
soils, control work.....	152, 227
Almonds, imports.....	722, 741-742
ALTER, J. CECIL, article on "Crop safety on mountain slopes".....	309-318
Alum, production from alunite, practices in Spain and Italy.....	528
Alunite, deposits in United States, source of potash, discussion.....	528
Ammonia sulphate, rice fertilizer, value.....	219
<i>Andropogon sorghum</i> . See Sudan grass.	
Anemometer testing, new instrument at Mount Weather Observatory.....	186
Animal diseases, eradication, studies.....	45
imported animals, exclusion requirements.....	161
remedies, supervision, distribution, etc.....	167-173
husbandry, instruction in high schools.....	479
review of work by Secretary.....	154-155
work at experimental farm, Beltsville, Md.....	173
Industry Bureau, work, review by Secretary.....	19-20, 42-50, 154-173
life, preservation by scientific investigations.....	172-173
nutrition, cooperative study in Pennsylvania.....	155
parasites, studies.....	172
tuberculosis, scientific studies.....	168
Animals, export, inspection requirements, number exported, etc.....	48, 161-162
farm, and their products, statistics.....	666-702
imported, inspection and quarantine, review of work by Secretary.....	48, 160-161
pure-bred, importations for breeding purposes, number, etc.....	161
tuberculin testing, number tested, etc.....	166
wild, importations during year.....	82-83
supervision, permits, etc.....	173-174
Ant, Argentine, injury to orange groves, and control methods.....	79
Antelope, danger of extermination, and need of protection.....	83
<i>Anthonomus grandis</i> . See Boll weevil.	
Anthraxnose, grape, control work.....	138
Anthrax, transmission by horseflies.....	387
<i>Anthus rubescens</i> , enemy of grain aphides.....	401, 402, 403
Antigens, preparation and distribution.....	171
Aphides, grain. See Grain aphides.	
Appalachian forest lands, acquisition under Weeks law.....	69
Appendix.....	541-750
Apple diseases, control work.....	137
summer, demand in eastern markets, effect on production, remarks.....	261
winter, importance of storage qualities.....	261
Apples, drying, processes, etc.....	507-508, 509
exports.....	23, 731, 738-739
introduction, note.....	120
new varieties, nomenclature, description, etc.....	262-267
Appropriations, Agriculture Department.....	86, 88, 96, 115, 177, 234
Apricots, dried, consumption in United States, 1909.....	510
drying, processes.....	511
introduction, note.....	120
Argols, imports.....	715, 741-742
Arid lands, utilization by means of irrigation, history and success.....	483-494
Arizona, date growing.....	514
Arkansas prairie lands, increase in value under irrigation.....	225
Arlington Farm, development, remarks by Secretary.....	130-132
Army horses, breeding by department, remarks by Secretary.....	43-44, 155
Arsenical dips, use in cattle-tick control.....	167
Asafetida, adulteration, investigations.....	54
Ashes, wood, source of potash salts.....	524-525
See also Wood ashes.	
Asia, plants, introduction, notes.....	119-120
Asparagus, growing in Charleston trucking district.....	429
rust, control studies and work.....	138

	Page.
Asses, numbers, in principal countries.....	670-672
<i>Astragalinus tristis</i> , enemy of grain aphides, examination of stomachs....	399, 402, 403
Atlantic Coast, trucking district.....	417
Atmosphere, upper, studies in Weather Bureau.....	36
Atmospheric conditions, northern hemisphere, use and value of synoptic charts. phenomena, studies by Weather Bureau.....	37 189-191
Avocado, introduction, note.....	119
Pollock, history and description.....	272
Bacilli, tubercle, studies.....	168
Bacon, exports.....	727
Bacteria, nitrogen-fixing, inoculation of soil, improved methods.....	139
Bagasse, utilization as fuel.....	198
Bait, poison, for cutworms.....	383
Balloons, sounding, use in upper air investigations.....	36, 190
Bamboo, timber, introduction and growing, Florida.....	119
Banana industry, growth.....	297-298
Bananas, dried, preparation.....	515
imports.....	719
ripening, agencies and changes.....	296
data from experiments, with respiration calorimeter.....	300-302
studying with respiration calorimeter, results, article by C. F. Langworthy and R. D. Milner.....	293-308
shipping method, etc.....	298
storage with oranges, studies.....	295
Banks, cooperation with cotton grower.....	454
loans to farmers, remarks.....	28
Bark disease, chestnut. <i>See</i> Chestnut-bark disease.	
Barkbeetles, injury to coniferous trees, control, remarks by Secretary.....	148-149
Barley, acreage and production, principal countries.....	589-592
production, farm value, prices and exports.....	592-596
crop, 1912, remarks.....	15
grain crop for northern Great Plains.....	467
prices, farm and wholesale.....	20, 21, 592-596
statistics, acreage, production, farm value, yield, prices, exports, etc.....	589-596
Barleys, introduction for Western States.....	119
Barometry tables, preparation by Weather Bureau.....	188
Barred-winged onion fly. <i>See</i> Onion fly, barred-winged.	
BEAL, F. E. L., article on "Our meadow larks in relation to agriculture".....	279-284
Bean, soy. New varieties, introduction.....	121
Bean-cake meal, rice fertilizer, value, note.....	219
Beans, acreage and production, principal countries.....	643-644
growing in Charleston trucking district.....	429
imports.....	725
improvement by pure-culture inoculation.....	139
prices.....	645
statistics, acreage, production and prices.....	643-645
Bear-tooth National Forest, timber supply to mining industries.....	408
Bedbugs, infestation of chickens, effects, control, etc.....	394
Beef, exports.....	23, 726-727, 737-738
production, investigations.....	155
Beeswax, imports.....	745
Beet seed, production, remarks.....	135
sugar crop, increase and relation to soil improvement.....	9
diseases, control work.....	135, 139
price, 1912.....	20
statistics.....	651-652
<i>See also</i> Sugar.	
Beetle, elm-leaf, egg parasite, introduction.....	147
southern pine, outbreak, and control work.....	76, 149
Beetles, dendroctonus, injury to forest trees, control studies.....	76, 148-149
spp., injury to pine and fir trees, control studies.....	76, 148-149
Beets, low production, note.....	10
sugar, diseases, control work.....	139
investigations.....	18, 135-136
Berries, dried, disuse, remarks.....	512

	Page.
Berry growing, Atlantic coast region, practices, soils, etc.....	425-426
Biological Survey Bureau, review of work by Secretary.....	80-86, 173-176
Bird reservations, conditions during year, and new ones created.....	84
Birds, economic relation to farming.....	81-82
enemies of alfalfa weevil and boll weevil.....	81, 82
food habits, cooperative studies.....	175
importations, 1912, supervision, numbers, etc.....	82-83, 173-174, 176
migratory, data collection, and need of protection.....	85, 176
native, publications on distribution and habits.....	174-175
relation to boll weevil, studies.....	81-82
grain aphids, article by W. L. McAtee.....	397-404
BISHOPP, F. C., article on "Some insect enemies of live stock in the United States".....	383-396
Bison Range, National, conditions.....	84
Bitter rot and bitter pit, apple, control work.....	137
salts, discovery, value.....	523
Black locust, use on dry lands, note.....	123
rot, grape, control work.....	138
Blackleg, potato, control work.....	138
vaccine distribution for control.....	47-48, 167-168
<i>Blastophaga grossorum</i> (fig wasp), introduction into California, and value.....	146
Bleaching flour, prohibition.....	245
Blight, peach control work.....	138
pear, eradication work.....	137
potato, control work.....	138
Blister rust, white pine, study and control work.....	137
Boards, administrative, Agriculture Department, personnel, duties, etc.....	244-245
Boll weevil, control by cultural methods, etc.....	79, 126, 146
Bond issues, road building, remarks.....	113
BONSTEEL, JAY A., article on "Truck soils of the Atlantic coast region".....	417-432
Bookkeeping, farm.....	11, 143
Bordeaux mixture, use in spraying for control of apple diseases.....	137
Borrowing money, cost to farmers.....	30
Botflies and bots, injuries to live stock, etc.....	387-389
BRAND, CHARLES J., article on "Improved methods of handling and marketing cotton".....	443-462
Bread making, use of fruits, practices.....	520
Breeding, animal, work of Animal Industry Bureau.....	43-44
horse, work of Department.....	43, 44, 154, 155
plant, development in 16 years, review by Secretary.....	213-214
poultry, experiments.....	44
timothy, note.....	121
Brines, source of potash.....	527
Broom corn, disease, cause.....	136
Brown rot, peach, control work.....	138
tail moth, control work, review by Secretary.....	146-147
Bubonic plague, conveyance by rodents.....	81
Buckwheat crop, 1912, remarks.....	16
price on farm.....	604-606
statistics, acreage, production, farm value, yield, prices, etc.....	604-606
Buffalo gnat, distribution, outbreaks, effect on live stock, etc.....	383-385
herds, National preserves, increase.....	84
Buffaloes, numbers, in principal countries.....	670-672
Buildings, rented, District of Columbia, cost, etc.....	86
Bull associations in dairy farming, remarks.....	156
Bureau. <i>See</i> Animal Industry; Biological Survey; Chemistry; etc.	
Burkett pecan, history and description.....	273-274
Butter, export, development of foreign markets.....	155
inspection on market.....	331
keeping quality, comparison of pasteurized and unpasteurized.....	158
prices.....	20, 684, 686
receipts at leading markets.....	687
statistics, prices and trade.....	684-685
storage, experiments and results.....	50, 158
By-products, beet sugar, remarks.....	18

	Page.
Cabbage, growing contiguous to onions, danger from onion thrips.....	325
in Charleston trucking district.....	429
soil, description, production of early vegetables, etc.....	422-423
Cactus fruit, dried, note.....	516
Caffein, toxicity, investigations.....	55
California, cotton growing.....	10
dried-fig industry, remarks.....	515
dried-fruit production.....	509
fruit insects, control work.....	78, 79
meadow lark, damage to crops by meadow lark.....	280
prune-producing region, importance.....	510
Calorimeter, respiration, use in studying the ripening of bananas.....	293-308
uses and value.....	222
Calves, castration, danger from screw worm, prevention.....	394
Camels, numbers, in principal countries.....	670-672
CAMERON, FRANK K., article on "Possible sources of potash in the United States".....	523-536
Campbell system, desiccating milk.....	343-344
Camphor growing, investigations.....	139
imports.....	749-750
Canadian field peas, crop for northern Colorado.....	467
Cancer, animal, similarity of crown gall disease.....	136
"Candied" dried fruit, preparation.....	508
Cane sirup and molasses, investigations.....	53
sugar, production 1912, remarks.....	18
<i>See also</i> Sugar.	
Canned goods, tin salts, prohibition.....	245
Canning foods, experimental work and studies of Chemistry Bureau.....	206
Carbon bisulphid, disinfectant for stored onions.....	330
Carbonate ponds, Western States, possible source of potash.....	527
Carob bean, dried, use, note.....	516
Cascade National Forest, annual increase of timber.....	59
Caterpillars, destruction by meadow larks.....	282-283
Cattle, breeding by Department.....	44
exports.....	726, 737-738
feeds, examination by Chemistry Bureau.....	57
grazing, National Forests, 1905 and 1912.....	242
imports.....	712
inspection for contagious diseases.....	161-163, 163-164, 165-167
losses from ox bot or heel fly.....	388
numbers, census years.....	677
in principal countries.....	666-669
raising, Alaska, possibilities, six years' demonstration.....	218, 219
scabies, control work.....	165-166
statistics, numbers, values, and prices.....	680-683
tick. <i>See</i> Tick, cattle.	
tuberculosis, control work, remarks by Secretary.....	166-167
United States, numbers, values, and prices.....	680-683
<i>See also</i> Dairy cows; Live stock.	
Cauliflower, growing contiguous to onions, danger from onion thrips.....	325
Cereals, growing in Alaska, results.....	218
semiarid districts, effect of present practices.....	463
production in 1912, remarks by Secretary.....	17
Charts, marine meteorological, increase since 1909.....	183-184
synoptic, value.....	37
Cheese, exports.....	737-738
factories, organization, inspection, scope of work, etc.....	157
imports.....	741-742
international trade.....	691
soft, European varieties, manufacture in United States, experiments.....	50
varieties, production, laboratory studies.....	159
Chemistry Bureau, development and work, review.....	50-57, 196-207
soil investigations.....	72
Chemists, Official Agricultural, Association, cooperation.....	197, 203
Cherries, candied, value, use of dyes, etc.....	511



	Page.
Cherry, Siberian bush, introduction and importation.....	120
trees, Japanese, gift of city of Tokyo to President's wife.....	77-78
Chesapeake strawberry, history and description.....	269
Chestnut bark disease, article by Haven Metcalf.....	363-372
cause and symptoms.....	364-365
control investigations.....	137, 367-371
losses from.....	363-364
spread and infection.....	366-367
nursery stock, inspection for bark disease.....	369
trees, diseased, individual treatment.....	370-371
ornamental, treatment of diseased.....	371-372
resistant to bark diseases, breeding, work.....	368-369
utilization of dead and dying, importance, value of timber, etc.....	367-368
varieties subject to bark disease.....	366
Chestnuts, dried, uses, note.....	516
Chicken bug, effect on poultry, control, etc.....	394
Chickens, infestation with bedbugs, effects and control.....	394
lice, remedies.....	396
prices to farmers.....	690
<i>See also</i> Poultry.	
Chinese plants, introduction, notes.....	119, 120
raisin, use in America, note.....	516
Chinquapin, susceptibility to chestnut-bark disease.....	366
Chipping sparrow, enemy of grain aphids, examination of stomach.....	400, 402, 403
CHITTENDEN, F. H., article on "Insects injurious to the onion crop".....	319-334
Cholera, hog, causes, control, etc., studies.....	168-169
Christmas trees and greens, quarantine notice.....	247
<i>Chrysomya macellaria</i> . <i>See</i> Screw worm.	
<i>Cimex lectularius</i> , infestation of chickens, effects, and control.....	394
Citron, description, candying, etc.....	513
Citrus by-products, study.....	52
fruits, green, artificially colored, prohibition.....	245
new types, propagation, note.....	134
trees, California, fumigation, value.....	148
diseases, cause.....	136
<i>medica macrocarpa cedra</i> , description, etc.....	513
Citrus-fruit growers' organizations, magnitude of work, benefits, etc.....	444
Climate, effect of heat of hills.....	311-312
Climatological reports and cooperative observations, increase.....	184
Cloud observations, work, and report by Weather Bureau.....	189
Clouds, weather folklore, explanations.....	381
Clover, improvement by pure-culture inoculation.....	139
red, seed handling, investigations.....	121
seed, prices.....	617-618
Cocoa and chocolate, imports.....	715, 741-742
Coconut, desiccated, preparation and uses.....	515-516
Coffee, exports and imports.....	660, 715, 728, 741-742
plantations, renovation work, Porto Rico Experiment Station.....	220
prices.....	658-660
statistics, production, prices and international trade.....	657-660
Cold, severe, in 1912, notes.....	546-548
storage, investigations.....	92
wave, warnings, value to farmers.....	179-180
Colleges, agricultural, growth, extent, number, and list.....	101-102, 542-544
work, improvement and extension since 1897.....	214-215
Coloring in tea, determination method, adoption.....	54
matter in foods, restrictions.....	245
Columbus Marsh, Nev., potash deposits, withdrawal from entry, etc.....	532
Commissions, loan, varying, note.....	30
Community work, agricultural, in high schools.....	480-481
Compress, cotton, use by cotton growers, necessity.....	456-458
Compresses, gin, advantages.....	458
Condensed and desiccated milk, article by Levi Wells.....	335-344
milk, history and growth of industry.....	335-336
keeping qualities.....	336
manufacture, selection of milk, equipment, processes, etc.....	336-339
<i>See also</i> Milk, condensed.	

	Page.
Cones, collection, management, equipment, production of tree, etc. ....	436, 437, 440
Confections, coating with gums, shellac, etc., prohibition.....	245
Congress, acts, references to .....	130, 134
Congressional seed distribution, remarks by Secretary.....	134
Conidia, chestnut bark disease, nature, appearance, etc.....	364-365
Contract supplies, testing by Chemistry Bureau.....	201
Cooking dried fruits, practices, suggestions, etc.....	520-522
processes, effects on food, investigations.....	222
Cooperation, Entomology Bureau, with State experiment stations.....	149
Experiment Stations Office, with stations, etc.....	213-214, 216
marketing perishable vegetable products, advantages, etc.....	355-362
Cooperative organization, cotton growers, studies of suitable methods, etc....	443-448
Copper sulphate in foods, prohibition.....	245
use in water purification.....	139
Copra, desiccated, preparation and uses.....	515-516
CORBETT, L. C., article on "A successful method of marketing vegetable prod- ucts".....	353-362
"Corinth" currants, varieties of grapes used, source.....	512
Cork oak, introduction, note.....	120
Corn, acreage, production, farm value, prices and exports.....	12, 559-562
principal countries.....	557-559
breeding experiments.....	128
cargoes, examination, notes.....	135
crop suitable to semiarid regions, value and use.....	467
culture, advances, remarks.....	127-128
exports.....	731, 738-739
freight rates.....	706, 708-709
international trade.....	564-565
Kafir, value and use on semiarid lands.....	467
prices, farm and wholesale.....	20, 562-564
root-worm, destruction by meadow larks.....	281-282
seed, improvement, experiment-station work.....	213
statistics, acreage, production, farm value, yield, prices, exports, etc. .	558-565
sweet, diseases, cause.....	136
weather conditions for, 1912, notes.....	546, 552, 554
Coronas, solar and lunar, causes, weather folklore, etc.....	377-378
Corrosion, steel and iron, study and control, Roads Office.....	210
Cotton, acreage, production, yield, prices, and exports.....	12-13, 621-624
bales, coverings, suggestions.....	450, 460
sampling, practices, need for regulations.....	459
"water-packed," cause.....	461
boll weevil, destruction by meadow larks.....	282
<i>See also</i> Boll weevil.	
compresses, Georgia and Oklahoma.....	456
diseases, cause, control work, etc.....	138
Egyptian, growing in California, etc.....	10, 123
exports.....	23, 728
tare practices.....	458
freight rates.....	707, 708-709
gin-cut, causes, disadvantages, etc.....	452
gins, recommendations.....	453
reduction in number, 1906-1911.....	447
growers, cooperative organization, discussion of needs and methods..	443-447
handling and marketing, methods, article by Charles J. Brand.....	443-462
losses from wasteful system.....	443
on farm, improved methods, need, suggestions.....	448-450
warehouse system, recommendations.....	453-455
holding by farmers, benefits, discussion.....	451-452
imports.....	716
lint, effect of storage of seed cotton on luster.....	449-450
moisture in bales, investigation, note.....	461
perennial, growing, Hawaii.....	216
planters, knowledge of cotton grades, necessity.....	455-459
prices, farm and wholesale.....	20, 21, 622-624
increase, October to April, discussion.....	451
production, principal countries.....	619-621
red spider, investigation and control methods.....	79

	Page.
Cotton, round-bale, basis of handling, remarks.....	457
selling, tare practices, standardization, etc.....	458-460
square-bale, basis of handling, remarks.....	457
standardization and grading, need.....	455-456
statistics, acreage, production, yield, prices, exports, etc.....	619-625
study, breeding, etc.....	126-127
sweating-out, effect on luster of lint.....	449
weather conditions for, 1912.....	550, 552, 553, 555, 556
weighing, variations, need of uniform laws, etc.....	460
Cottonseed oil, exports.....	740-741
international trade.....	624-625
value, 1912.....	14
Cover crops, winter, value in tobacco growing.....	129
Cowpeas, new, introduction, note.....	121
Cows. <i>See</i> Dairy cows.	
Cow-testing associations, work, growth, etc.....	49, 156
Coxville soils, occurrence, descriptions, value for trucking, etc.....	424-426
Cranberry diseases, studies and control, experiments.....	138
growers, special warnings by Weather Bureau.....	39, 182
Cream, grading, value in improvement of cream and butter.....	49-50
quality, investigations.....	158
Creameries, organization, inspecting, scope of work, etc.....	49-50, 157
semiarid regions, establishment and value, remarks.....	465-466
Credit, agricultural, survey of conditions.....	25-30
farmers' security and sources.....	26, 28
Crop liens, remarks.....	27
pests, life-history studies and publication.....	150
Reporter, description, growth, and circulation, remarks by Secretary.....	92, 194-195
reporters, salaried, work.....	91
Reporting Board, establishment, and procedure methods.....	192-193
development of system since 1862, remarks by Secretary.....	191-194
reports, simultaneous publication.....	193
sources of information, compiling, estimates, etc.....	90-92
results, largest in records of United States, details.....	11-19
safety on mountain slopes, article by J. Cecil Alter.....	309-318
Crops, chief, remarks by Secretary.....	12-19
Great Plains area, character.....	468
introduction for semiarid lands.....	118-119
new, and new industries, introduction in recent years, remarks.....	117-122
principal, statistics.....	557-654
production of 1912 compared with 1911.....	18-19
relation to alkali and dry-land conditions.....	125-126
semiarid regions, principal.....	467
world, principal farm products.....	557-565
Crosby, Dick J., article on "Agriculture in public high schools".....	471-482
Crossties, hewed, opportunities for small operators.....	411
timber supply from national forests.....	408
Crown-gall, plant, determination, similarity to animal cancer, cause, etc.....	136
"Crystallized" dried fruit, preparation and value.....	508, 517
Cucumbers, growing in Charleston trucking district.....	429
Cultures, disease-producing, supply to scientists.....	172
Curly-top, sugar beets, control work.....	139
Currants, dried, foreign supply, note.....	512
imports.....	745
Cushman-Coggeshall method of extraction of potash from feldspars.....	529-530
Cutworms, damage to onion crop, occurrence, and methods of control.....	332-333
destruction by meadow larks.....	283
with poison bran mash.....	383
Dairy cows, butter fat, increase.....	155-156
(milch cows), number, census years.....	677
numbers, in principal countries.....	666-669
values and prices.....	681-682
type used in semiarid regions.....	466
Division, Animal Industry Bureau, review of work by Secretary.....	155-159
farming, development and improvement, work in South and West.....	48-49

	Page.
Dairy farming, semiarid regions, advantages.....	465-467
herd, Great Plains area, feeding.....	468-469
semiarid regions, advantages.....	464-465
industry, review of work by Secretary.....	155-159
products and mill feed, suggestion.....	11
exports.....	726
imports.....	712
inspection, necessity and value.....	49-50
investigations by Chemistry Bureau.....	53
1912, remarks by Secretary.....	19, 20
records, value, scope, etc.....	48-49
research laboratories, work.....	50
stock, improvement in semiarid regions, suggestions.....	469-470
Dairying, advantages.....	466, 467
and its relation to agriculture in semiarid sections, article by A. K. Risser.....	463-470
Colorado, returns per cow.....	470
improvement and development.....	155-156, 196
instruction in high schools.....	475
semiarid regions, marketing the products, management, etc.....	465-466, 468
Damping-off, sugar beets, control work.....	139
Dasheen, introduction, note.....	119
Date palm, growing, ripening, and propagation, experiments.....	119
introduction into United States, outlook.....	514
varieties, importations from Egypt, etc.....	120
Dates, climatic requirements, imports, growing in United States, etc.....	514
imports.....	745
DAY, P. C., review of weather conditions, 1912.....	546-556
Deerlodge National Forests, timber supply to operators.....	405-406
Deforestation of watersheds, relation to floods, study by Weather Bureau.....	187
Demonstration farms, Hawaii, remarks by Secretary.....	104-105
work, farm drainage.....	108-109
farmers' cooperative, growth, results, etc.....	141-142
insects injurious, value.....	149
Denatured alcohol, studies by Chemistry Bureau.....	201
<i>Dendroctonus</i> , spp., injury to coniferous trees, control work.....	148-149
Desert basins, examination for potash deposits, work of Bureau of Soils.....	531-532
formation and deposits, potash, etc.....	530-533
plants, possible source of potash.....	526
Desiccated fruits. <i>See</i> Dried fruits.	
milk, article by Levi Wells.....	335-344
development and scope of industry, markets, etc.....	339-344
plants, number and output.....	340
Dietary studies, value, etc.....	222
Digestibility, foods, investigations.....	221
Dips, arsenical, use in cattle tick control.....	167
Disbursements, Accounts, Division, review of work.....	86-87
Diseases, animal, control, laws, enforcement.....	249-250
studies.....	45-48, 162-163, 167-173
conveyance by insects, investigations.....	78
Division. <i>See</i> Accounts Division; Publications Division.	
Dorcus, Frederick, history of Monocacy apple.....	263-266
Douglas pear, history and description.....	267-268
Dourine, eradication, remarks.....	45
study and method of diagnosis.....	169, 170
Draft horses, breeding by department.....	43
Drainage, farm, progress.....	108-109
investigations, progress, scope, work, etc., remarks by Secretary.....	108-109, 226-228
Dressed poultry industry, features, management, etc.....	286-287
<i>See also</i> Poultry.	
Dried apples, production in United States, exports, etc.....	509
apricots, consumption in United States, 1909.....	510
currants, varieties of grapes used.....	512
fruits, consumption, production and value in United States.....	508-509
economy in use.....	520-522

	Page.
Dried fruits, figs, raisins, and other, and their use, article by C. F. Langworthy.	505-522
food value.....	516-519, 521
preparation.....	506-507
<i>See also</i> Fruits, dried; Fruits, evaporated.	
peaches, consumption in United States, 1909.....	510
Dried-fruit industry, development in United States, note.....	505
Drought and dry weather, 1912, notes.....	547, 551, 552, 554
Drug Division, Chemistry Bureau work, review by Secretary.....	54-55
laboratory, establishment, and work since 1903.....	202
plants, investigations and special problems.....	139-140
Drugs and food act enforcement investigations, and results.....	32, 202-207, 252
Inspection Board, duties and important decisions.....	244-245
inspection by Chemistry Bureau.....	54-55, 203-204
<i>See also</i> Food and Drugs.	
Dry farming, extension, experiment station work.....	213
seeds for distribution, note.....	134
lands, crops for, introduction by Department.....	118-119
milk. <i>See</i> Desiccated milk.	
Driving apples, processes.....	509
fruits, artificial processes, advantages of.....	506
changes caused, effect of different processes, etc.....	505-506, 507
lumber, new type of kiln.....	71, 239
Dry-land agriculture, investigations, Great Plains region, and stations.....	124-125
farming, disadvantages.....	463-464
Eastman apple, history, and description.....	262-263
Economics, household, assistance by Department.....	223-224
Education, agricultural, progress since 1897.....	214-215
agriculture in public high schools, article by Dick J. Crosby.....	471-482
school of instruction, Weather Bureau.....	191
Educational work, Chemistry Bureau.....	202
Egg candling demonstrations, by produce dealer, suggestions.....	347-348
Eggs, buying on quality basis by dealer, discussion.....	345-347
deterioration in handling and marketing, losses, study of control methods.....	45
exports.....	22, 726
handling and marketing, cooperative, study of conditions, losses, etc.....	45
improvement by produce dealer, etc., article by H. C. Pierce.....	345-352
infertile, advantages in handling and marketing.....	45, 154
investigations, work of Chemistry Bureau.....	51, 52
losses between producer and consumer, annual.....	345
prices.....	20, 687, 689
variation for different grades.....	346
production, poultry-breeding experiments.....	19, 45
receipts at leading markets.....	688
Egyptian cotton. <i>See</i> Cotton, Egyptian.	
Ekenberg system for desiccating milk.....	341-342
Elk feeding, Jackson Hole, Wyoming.....	84
Employees, Department, increase in numbers.....	114-115
<i>Endothia parasitica</i> , cause of chestnut bark disease.....	364
Engineers, highway, training, by Roads Office.....	112, 209-210
rural, instruction in high schools.....	480
English currants, varieties of grapes used, sources.....	512
sparrow, enemy of alfalfa weevil.....	81
Entomology Bureau, work, growth, etc., remarks by Secretary.....	75-80, 144-150
Estimates for fiscal year 1914, amount, and purposes of increase.....	86-87
<i>Euxoa</i> spp. <i>See</i> Cutworms.	
Evaporated cream, application of term.....	336
fruits, preparation.....	506-507
<i>See also</i> Dried fruit.	
milk, application of term, and processes in making.....	336
<i>See also</i> Desiccated milk.	
Evaporation studies, improvement in methods and devices, 1907-1909.....	186, 187
Exhibits, roads, models, educational value.....	209
Experiment Station, Bethesda, Md., scope, equipment, etc.....	173
stations, agricultural, location, and directors.....	544-545
growth and development since 1897.....	212

	Page.
Experiment stations, insular, needs .....	103
review of work by Secretary .....	102-106
Office, cooperation with State work .....	213-214, 216
development, review by Secretary .....	211-221
relations with agricultural experiment stations ..	95-101
review of work by Secretary .....	95-110
Experimental farms, Agriculture Department, location, equipment, work, etc.	173
Exports, agricultural, remarks and tables .....	22-24, 726-735
selected articles, 1851-1912 .....	736-741
forest products .....	24, 232, 729, 746-749
Exsiccator, milk, description .....	341-342
Fairs, county, usefulness in improving quality of poultry and eggs .....	348
Fallon field station, remarks on work .....	123
Farm animals and their products, statistics .....	666-702
bookkeeping, methods, investigations .....	11, 143
drainage, demonstration work .....	108-109
equipment, studies .....	143
management, field studies and demonstrations, methods, etc. ....	142-144
surveys, cooperative studies .....	143
mechanics, instruction in high schools .....	480
operations, cost studies .....	143
products, estimate of total in 1912 .....	20
perishable, per cent of consumers' price received by grower ..	354
prices, comparison for recent years .....	20-22
purchasing power investigations by Statistics Bureau .....	94
transportation, rates, etc. ....	703-711
values, principal crops .....	561,
570, 585, 593, 600-601, 604, 609, 610, 613, 614, 627, 633, 637	
wastes, utilization in manufacturing industries .....	199
Farmer, retired, need on farm .....	11
Farmers, aid by Department with seed improvement .....	130
benefits from proximity of national forests .....	412-413
Bulletins, demand, output and cost, 1907-1912, etc .....	88
credit for, conditions and difficulties .....	25-30
demonstration work, cooperation .....	141-142
dry land, aid by department .....	122-124
Institutes, appointment of specialist, and duties .....	215, 216-217
field for aid in improvement of quality of poultry products ..	350
number, increase, etc. ....	102, 215-218
irrigation, aid of Department .....	122-124
national forest region, winter employment .....	412-413
organizations for marketing products, some examples .....	444-447
rice, aid by department .....	118
Farming, diversified, on newly settled irrigated lands, importance, discussion	487-488
dry-land, disadvantages .....	463-464
Farms, demonstration, Hawaii .....	104-105
mountain, advantages for fruit growing, etc. ....	310-318
number affected by railway promotion of agriculture .....	711
FARQUHAR, HENRY H., article on "Seed collection on a large scale" ..	433-442
Feed, cattle, examination and study by Chemistry Bureau .....	57, 197
Feeding dairy cows, effect of winter feeding on dry farm .....	468
Feldspar deposits, source of potash, extraction methods, investigations ..	528-530
Fertility, soil, investigations by Soils Bureau .....	74-75
Fertilizer investigations, Soils Bureau .....	73
smelter waste, use .....	198
Fertilizers, commercial, use, value, etc., discussion .....	153
deterrents for onion root maggots, various kinds, use, etc. ....	331
potash sources in United States, article by Frank K. Cameron ..	523-536
Fever, Malta, causes, control, etc., studies .....	161, 169
spread to man by goats, control methods, etc .....	47
swamp, among horses, control .....	170
Texas, eradication work .....	163-164
tick, exclusion from Southern States .....	10
Fibers, animal, exports .....	713, 726
vegetable, imports .....	716

	Page.
Field sparrow, enemy of grain aphides, examination of stomach.....	400, 402, 403
Fig fertilizing insect (fig wasp), establishment in California, studies and work..	146
industry, establishment, development, and outlook.....	515
wasp (fig fertilizing insect), establishment, work etc., in California.....	146
Figs, dried, sources, imports.....	514-515
imports.....	745
laxative properties.....	519
raisins, and other dried fruits and their use, article by C. F. Langworthy.	505-522
Fire protection for forests, improvement in organization.....	67-69
State laws.....	237
Fires, forest, losses, 1911 and 1912, causes, etc.....	67
Firmin-Thompson method of extraction of potash from feldspar.....	529
Flatwoods section, Atlantic coast trucking district, climate, etc.....	417-420
Flavor fruits, character of class.....	505
Flax, acreage, principal countries.....	631-633
imports.....	742-743
statistics, acreage, production, farm value, and prices.....	631-633
Flaxseed, acreage, production, farm value, and prices.....	633-635
crop, 1912, remarks by Secretary.....	16, 20, 21
exports.....	734
Flood, Mississippi River, effect on sugar industry.....	18
service, Weather Bureau, extension since 1897, remarks by Secretary.	182-183
warnings, 1911-12, list.....	38
Floods, losses, and savings by weather warnings.....	38-39, 183
1912, notes.....	548, 549, 550
relation to deforestation of watersheds, study by Weather Bureau.....	187
Florida, Rhodes grass, orders for Australian seed, note.....	497
white fly, control work.....	78
Flour bleaching, prohibition.....	245
exports.....	23, 732, 740-741
freight rates.....	709
prices and trade.....	576, 578, 579
Flower bug, insidious, enemy to onion thrips, note.....	322
Fly, biting, disease conveyance.....	78
fruit, Mediterranean, control in Hawaii.....	79-80
house, spread of disease, control work.....	148
stable. <i>See</i> Stable fly.	
white, Florida orange groves, control work.....	78
Folklore, weather.....	373-382
Food adulteration, investigations, Chemistry Bureau.....	205
and Drug Inspection Board, duties and important decisions.....	244-245
drugs act, enforcement, and results.....	32, 202-205, 206-207, 252
canning, studies by Chemistry Bureau.....	52
fruits, preparation and value.....	505
inspection decisions, important.....	245
work of Chemistry Bureau.....	203-204
products, handling, studies by Chemistry Bureau.....	205-206
standards, establishment.....	203
Foods, digestibility, investigations.....	221
inspection by Chemistry Bureau.....	55
Foot-and-mouth disease, control work by Department, commendation.....	161, 163
introduction into United States, in vaccine, etc.....	161
outbreaks in various States, control work, etc.....	163
Forage crops, Great Plains area, losses from poor handling.....	468-469
introduction, remarks by Secretary.....	121-122
destruction by rodents.....	81
grasses, Indian, introduction, note.....	120
poisoning horses, control studies.....	170
sorghums, notes.....	122
Forecasting, accuracy, percentage increase since 1893.....	178
Forecasts Weather Bureau, scope, value, etc.....	36-37, 177-181
Foreign trade, agricultural products, 1912, remarks by Secretary.....	22-24
Forest diseases, control experiments.....	136-137
fires, losses, 1911 and 1912, causes, etc.....	67
insects, control work.....	76
investigations, experimental studies, stations and laboratories.....	70-71

	Page.
Forest lands, unproductive, area, reforestation, remarks.....	433
management, development of present system.....	240-242
improvements due to prevalence of chestnut-bark disease.....	368
progress during year.....	66
nursery stock, diseases, control studies.....	137
owners, assistance from Department, results.....	235-236
pathology, studies and experiments.....	136-137
products, exports.....	24, 232, 729, 746-749
imports.....	716-719, 746-747, 749-750
laboratory, work.....	240
special opportunities for small operator, etc.....	410
Réserveation, National Commission, personnel and duties.....	248
resources, extent, investigation by Department.....	239
use.....	234
Service, cooperation in public works, etc.....	65-66, 69-70
forest-seed collection, work.....	433-434
growth, work, value, etc.....	229-243
legal business handled by solicitor.....	33-34, 257
review of work, by Secretary.....	58-71
trees, seed collection, article by Henry H. Farquhar.....	433-442
Forestry, American, scientific development.....	235-237
Bureau. <i>See</i> Forest Service.	
scientific, results in conservation work.....	232-233
Forests, destruction, results, remarks by Secretary.....	229-234
effect on climate and stream flow, studies by Weather Bureau.....	39
injury from insects, control investigations.....	148-149
National, area, boundaries, administration, etc., work, review.....	65
climate and stream flow, studies.....	39
creation, increase, original and present area.....	234, 242, 254
diseases, control experiments.....	136-137
public control, necessity, etc.....	415-416
receipts from various sources.....	66
regulations, revision.....	33
timber for small operators, article by William B. Greeley.....	405-416
sales, purpose of regulations.....	413
stand and cut.....	58
transfer to Department of Agriculture.....	241-242, 254
trespasses, work of solicitor's office.....	254-255, 257
utilization, conservation policy, relation to, etc.....	233, 234, 242-243
protection, early plans.....	229-230
State, reservations and administration.....	237
Fowls, diseases, control studies.....	170
<i>See also</i> Poultry.	
Freight rates, grain and meats.....	704-710
statistics, railway.....	703-710
Frost dangers to fruit districts, advantages of mountain farms.....	312-313
studies and warnings by Weather Bureau.....	39, 181-182
Frosts, 1912, notes.....	550, 553, 554, 555
Fruit, use in cake and "cheeses," suggestions.....	508, 520
districts, danger of frosts, advantages of mountain farms.....	312-313
mapping.....	132
fly, Mediterranean, control in Hawaii.....	79-80
fresh, yield of dried product.....	505
growing, Alaska, development.....	218
commercial, variety problems, importance.....	261-262
effect of thawing.....	313-314
Hawaii, development of industry.....	219
Porto Rico, development of industry.....	219-220
hybrids, product by South Dakota Experiment Station.....	213
industry, frost damage, extension of forecast work.....	39
lists, varieties recommended for planting.....	261
marketing, remarks.....	132
products, experiments and studies by Chemistry Bureau.....	52-53
protection, experiments by Weather Bureau.....	182
ripening, control, its commercial importance, etc.....	293-294, 295
stocks, use in dry lands, note.....	122



	Page.
Fruit storage, remarks by Secretary.....	133
transportation, remarks by Secretary.....	133
varieties, studies, objects.....	261-262
Fruits, changes caused by drying, effect of different processes, etc.....	505-506
diseases, control work.....	137-138
dried and evaporated, preparation.....	506-508
figs, raisins, and other, and their use, article by C. F. Langworthy.....	505-522
food value.....	516-519
uses as food, preparation, value, etc.....	519-520
<i>See also</i> Dried fruits; Evaporated fruits.	
exports.....	731
flavors, source.....	518
imports.....	719
introduction by Department.....	119-120
laxative properties.....	519
new, promising, article by William A. Taylor and H. P. Gould.....	261-278
preserving with sugar.....	511
use in cakes, practices.....	520
value in diet.....	517-519
Fumes, smelter, condensation and utilization as fertilizer.....	198
Fumigation, citrus trees, California, value.....	143
hydrocyanic, improvement.....	79
Fungicide and Insecticide Board, duties and investigations.....	31-32, 245-246
Fungicides, chemical examination, importance to farmers.....	56-57, 198-199
Fur-bearing animals, rearing, importance and profit.....	80-81
<i>Fusarium</i> spp., fungous cause of plant diseases, control work.....	138
Gadfly, black, injuries to live stock.....	386-387
Gallworm, nematode, control, notes.....	123
Galveston storm, 1900, losses of life and property.....	179
Game, big, data collection.....	85
laws, Federal, enforcement by department.....	250-251
legislation, compilation and index.....	85
protection, enforcement, cooperation with States, etc.....	85, 175-176
“Garawa.” <i>See</i> Sudan grass.	
<i>Gastrophilus equi</i> , injury to live stock.....	387-389
Georgia, Savannah, trucking district, area and production.....	429
sirups, investigations by Chemistry Bureau.....	198
Giant kelps, Pacific coast, source of potash, investigations, outlook, etc.....	533-535
<i>See also</i> Kelps.	
Gid, sheep, investigations and treatment.....	172
Gin compression, cotton, advantages.....	458
press boxes, standardization, suggestions.....	453
Ginnery, cooperative, at Montgomery, Ala., capacity, advantages, etc.....	445
Ginning cotton, injury to fiber, causes.....	452-453
Gins, cotton, reduction of number, 1906-1911.....	447
Ginseng diseases, control work.....	139
Gipsy moth, control investigations, Entomology Bureau.....	75-76, 146-147
Glanders, causes, control, etc., studies.....	169
Glucose, exports, remarks.....	23
Gnat, Buffalo. <i>See</i> Buffalo gnat.	
conveyance of pellagra in Italy, note.....	78
Goats, breeding, work of department.....	44
conveyance of Malta fever to man.....	47
numbers, in principal countries.....	670-672
Goldfinch, enemy of grain aphids, examination of stomachs.....	399, 402, 403
GOULD, H. P., and WILLIAM A. TAYLOR, article on “Promising new fruits”.....	261-278
Graduate School of Agriculture, establishment and continuance.....	214, 215
Grain aphides, number eaten by different birds, table, etc.....	401-404
relation of birds, article by W. L. McAtee.....	397-404
changes in storage and transportation.....	134
crops, semiarid regions.....	467
exports.....	731-732
freight rates.....	708, 709
grading and standardization, remarks by Secretary.....	134-135
growing, California, destruction by meadow lark.....	280

	Page.
Grain growing, semiarid regions, advantages of dairying.....	466
imports.....	720
tests and analyses, remarks.....	134
Grain-growers' organization, success in Northwestern States.....	444
Grains, drought-resistant, introduction.....	118-119
examination by Chemistry Bureau.....	57
improvement by breeding, work of experiment stations.....	213
Grape diseases, control work.....	138
growers, special forecasts for.....	39
sugar, exports, remarks.....	23
Grapefruit peel, crystallized, uses, note.....	513
Grapes, curing for different purposes.....	512
imports.....	719
new, notes.....	119, 120
production in South, encouragement, note.....	133
Grass, Sudan and Tunis. <i>See</i> Sudan and Tunis.	
Grasses, forage, introductions, notes.....	120, 121
new for the South, article by R. A. Oakley.....	495-504
Grasshoppers, destruction by meadow larks.....	283
Grazing permits, national forests, 1905 and 1912.....	242
regulations, national forests, policy and administration.....	241, 242, 255, 257
Great Basin, vegetation study.....	126
<i>See also</i> Dry land; Irrigation.	
Plains region, principal crops.....	467
reconnaissance, soil surveys.....	71, 72
vegetation study.....	126
<i>See also</i> Dry land; Irrigation.	
Salt Lake, character of residue.....	533
GREILEY, WILLIAM B., article on "National forest timber for the small operator".....	405-416
Green bug, outbreaks, description, losses, etc.....	397
Ground squirrels, destructiveness and danger to health.....	81
water, supply and movement, studies by Soils Bureau.....	74
Guam Experiment Station work, crops and live-stock improvement.....	106, 220-221
Gums, imports.....	717
rubber, imports.....	749-750
Gypsum, use on western soils, note.....	183
<i>Hæmatopinus</i> spp. pests of live stock, control.....	395
Halos, solar and lunar, causes, weather folklore, etc.....	377-378
Hams, exports.....	23, 727
Havens pecan, history and description.....	277-278
Hawaii Experiment Station, review of work by Secretary.....	104-105, 219
Mediterranean fruit fly, control.....	79-80
Hay, acreage, production, value, yield, prices, and exports.....	613-617
crop, 1912, remarks.....	12
crops, grasses suitable to South and dry regions, need, investigations, etc..	495
exports.....	732
grasses, requirements.....	498
growing, relation to tobacco growing.....	129
prices, farm and wholesale.....	20, 21, 613-614, 616-617
Rhodes grass, value, yield, etc.....	498
statistics, acreage, production, farm value, yield, prices, exports, etc..	613-617
Health of man, insects affecting, work of Entomology Bureau.....	78
public, relation of abortion among animals.....	170
Heat, absorption and radiation by hills, effect on climate.....	311-312
Heel fly, pest of cattle, manner of infection, etc.....	388-389
HEISKELL, HENRY L., article on "The commercial weather map of the United States Weather Bureau".....	537-539
Hemp, imports.....	742-743
Hides, exports.....	727
imports.....	714, 746
international trade.....	673-677
High schools. <i>See</i> Schools.	
Highway engineering, training by Roads Office.....	112, 209-210
Highways. <i>See</i> Roads.	

	<b>Page.</b>
Hills, heat absorption and radiation, effect on climatic conditions.....	311-312
Hog cholera, causes, control, etc., scientific studies.....	46-47, 168-169
serum, preparation and distribution.....	46-47, 169
Hogs, exports.....	726
numbers, in principal countries.....	666-669
raising on dairy farm in semiarid regions.....	466
statistics, numbers, values, and prices.....	700-702
<i>See also</i> Live stock.	
Holstein cattle, breeding work, North Dakota.....	44
Home economics, assistance by Department.....	223-224
Homogenizer, use in manufacture of condensed milk.....	338
Hookworm, transmission, distribution, etc., studies.....	172
Hops, exports.....	732, 740-741
growing, improvement, etc.....	17, 140
imports.....	742-743
international trade.....	642
price, 1912.....	20, 21, 641
production.....	640
statistics, production, prices, and trade.....	640-642
Horn fly, life history, habits, damage to live stock, control, etc.....	390-391
Horse breeding, work of Department.....	43-44, 154-155
diseases, control studies.....	169, 170
Horseflies, control measures, damage to live stock, etc.....	386-387
outbreak in Oklahoma, 1896-7.....	386-387
Horses, breeding, Animal Industry Bureau, remarks by Secretary....	43-44, 154, 155
exports.....	726
forage poisoning in West, control studies.....	170
grazing, national forests, 1905 and 1912.....	242
importation, pedigree certificate, requirement.....	154
imports.....	712
injury by insects.....	384, 386-389, 391-394, 712
numbers, in principal countries.....	666-669
United States.....	677-680
raising on dairy farm in semiarid regions, note.....	466
statistics, numbers, values, and prices.....	678-680
<i>See also</i> Live stock.	
Horticultural Board, Federal, organization and work.....	77, 246-247
Horticulture, instruction in high schools.....	479
Hot weather, 1912, note.....	551
House fly, spread of disease, control work.....	148
Humid regions, irrigation supplementary, extension.....	225
HUMPHREYS, W. J., article on "Some useful weather proverbs".....	273-332
Humus, soil, investigations.....	139
Hunting accidents, data collection, and efforts to obviate by legislation.....	85
licenses, adoption by States.....	176
Hurricanes, announcement by radiotelegraph.....	178-179
Hybridization, alfalfa, remarks.....	121
cotton, cause of deterioration.....	126
Hydrocyanic-acid gas fumigation, improvement in method.....	79
Ice, break-up on navigable waters, 1912.....	549
Idaho school lands, exchange for forest lands, examination, etc.....	65
Illustrations, work of Publications Division.....	90
Importations, birds and mammals, 1912, supervision, statistics, etc.....	82-83
Imports, agricultural, 1908-1912.....	712-725
remarks by Secretary.....	24
selected articles.....	736, 741-750
Index, game legislation, work by Biological Survey Bureau.....	85
Indiana, Starke County, damage from onion thrips.....	319
Infantile paralysis, transmission by stable fly.....	78, 391
Inoculation, pure-culture, improvement in clover, alfalfa, etc.....	139
Insect enemies of live stock in United States, article by F. C. Bishopp.....	383-396
onion thrips.....	322-323
Insecticide act, enforcement, work of solicitor's office.....	34, 253-254
and Fungicide Board, duties and investigations.....	31-32, 245-246
Insecticides, chemical examination, importance to farmers.....	56-57, 198-199
Insects affecting health of man, work of Entomology Bureau.....	78

	Page.
Insects, destruction by meadow lark.....	281-283
disease-carrying, investigations and control work.....	148
forest, control work and studies.....	76
injuries to live stock.....	383-396
injurious, control, cooperative studies, etc.....	149
importations, control work.....	145, 247, 254
introduction, and losses caused by them.....	247
life history, studies, and results.....	150
to onion crop, article by F. H. Chittenden.....	319-334
injury to trees, control work.....	148-149
Inspection, animals, export and import.....	48, 160-161
dairy products, necessity and value.....	49-50
food and drugs, work, Chemistry Bureau and branch laboratories.....	203-204
meat, law enforcement, cases, etc.....	34, 252-253
remarks and statistics.....	42-43, 159-160
<i>See also</i> Meat inspection.	
plant, work.....	77-78
road, remarks by Secretary.....	111-112
Instruments, Weather Bureau stations, equipment, etc.....	185-187
Insular experiment stations, work, extension, etc.....	102-106, 212, 218-221
Interest, rates to farmers, remarks.....	29
Interior Department, cooperation in Mississippi flood report.....	38
settlement of claims.....	65-66, 256
Iowa, apple suitable to, development.....	262-263
Irrigated areas, need of diversification of industries.....	487-488
lands, colonization settlement, advantages.....	486-487
conveniences for settlers, suggestions, and value.....	489-490
extravagant exploitation.....	491-492
inflation of values, effect on permanent settlement.....	486-487
need of settlers.....	107
new, relation of State to settlement.....	492-493
settlement, article by Carl S. Scofield.....	483-494
Irrigation farmers, aid by Department, remarks.....	122-124
investigations, Experiment Stations Office.....	106-108
progress, work, etc.....	224-226
projects, extent, needs, etc.....	106-108
water waste, reform.....	225
Jail sentences, food and drug act, enforcement.....	32
Japan, Tokyo, shipment of flowering cherry trees to President's wife.....	77-78
Jujube, Chinese, introduction, note.....	120
paste, use in America, note.....	516
<i>Junco hyemalis</i> , enemy of grain aphides.....	401, 403
Just system, desiccating milk.....	343
Jute, imports.....	742-743
Kafir corn, crop suitable to semiarid region, value and use.....	467
Kale growing in Norfolk trucking district.....	431
"Kali Syndikat," controversy with American importers of potash salts, results.....	524
Kaniku National Forest, seed collection, 1911, operations.....	437-442
Kansas, aid for agricultural instruction in high schools.....	474
Kelp groves, value to United States, outlook.....	535-536
<i>Macrocystis pyrifera</i> , habitat, area, yield of potash, value, etc.....	533, 534-535
marketing, method.....	534
<i>Nereocystis luetkeana</i> , source of potash, discussion.....	533
potash source, protection and utilization.....	73
Kelps, giant, Pacific coast, source of potash, investigation, outlook, etc.....	533-535
Kerosene emulsion, remedy for onion root-maggots.....	331
use against bedbugs and live-stock insects.....	394, 395, 396
with sand, deterrent for onion root-maggots.....	331
Kiln for drying lumber, improved type, invention.....	71, 239
Kiosks, installation in cities by Weather Bureau.....	187
Kites, Weather Bureau, description and equipment, and work since 1905.....	36,
186, 189-190	
Kootenai National Forest, annual lumber cut.....	409
Kumquat, crystallized, imports, note.....	513

	Page.
Labor, cotton compresses, responsibility of laborers for poor bales.....	456
wages and supply, investigations.....	93
Laboratories, dairy research work.....	50, 158-159
Lacey Act, enforcement by Department.....	35, 250-251
Lachnosterna, destruction by meadow larks.....	282
Ladybirds, enemies of onion thrips.....	322
Land claims, national forests, examination and settlement.....	256-257
classification in national forests, work of Department bureaus.....	64, 72
condition after production of sugar beets.....	18
productiveness, remarks by Secretary.....	153
seekers, classes, and purposes, discussion.....	484-485
values, inflation in newly irrigated sections, discussion.....	486-487
Lands, agricultural, in national forests, listing for settlement.....	62-65
forest, acquisition under Weeks law, areas, location, and price.....	69
irrigated, needs, management, etc.....	106-108
LANGWORTHY, C. F., and R. D. MILNER, article on "Some results obtained in studying ripening bananas with the respiration calorimeter".....	293-308
article on "Raisins, figs, and other dried fruits, and their use".....	505-522
Larch, Siberian, introduction, note.....	120
Lard compounds, exports.....	727
exports.....	22, 727
freight rates.....	708
Lark, meadow, economic importance.....	279-284
food habits.....	280-284
relation to agriculture, article by F. E. L. Beal.....	279-284
Law, Federal, plant inspection and quarantine.....	77
plant introduction, for exclusion of insects and disease.....	10
pure-food, enforcement by Chemistry Bureau.....	203-204
Laws, administration by Department.....	32-36, 248-258
Laysan Island bird reservation, conditions.....	84-85
Leaf-roll, potato, control work.....	138
Leaf-spot, sugar beets, control work.....	139
Leathers, studies by Chemistry Bureau.....	57, 199-200
Lecture work of Farmers' Institutes Office.....	217
Roads Office.....	210
Legal business, Forest Service, handled by Solicitor, record.....	257
Legislation. <i>See</i> Law; Laws.	
Legumes, annual, note.....	122
forage, introduction.....	120
improvement by pure-culture inoculation.....	139
Lemon peel, crystallized, uses, note.....	513
Lemons, imports.....	719, 746
Lettuce, growing in Beaufort trucking district.....	429
Wilmington trucking district.....	430
Leucite, source of potash, remarks.....	528
Library, Department, collections, catalogues, growth, etc.....	95, 228-229
Weather Bureau, number of books and pamphlets, additions, etc.....	191
Lice, biting, infestation of live stock, remedies, etc.....	395-396
grain, relation of birds, article by W. L. McAtee.....	397-404
sucking, infestation of live stock, effects, and control.....	395
Licorice root, imports.....	720, 742-743
Liebig, discovery of fertilizer value of potash salts.....	523
Light burning of forests, destructive results.....	67
Lime, use on western soils.....	123
Lime-sulphur solution, use in spraying for control of apple and peach diseases.....	137-138
wash, use and value in San Jose scale control.....	146
Liquors, exports.....	732-733
imports.....	720-721
Litchi nut, use in America by Chinese, note.....	516
"Little peach," control work.....	138
Live stock diseases, quarantine law enforcement.....	45, 48, 249-250
effect of insects.....	383
export, inspection requirements, numbers exported, etc.....	161-162
freight rates.....	707

	Page.
Live stock, importation restrictions, permit requirements, etc. . . . .	161
industry, review of work by Secretary . . . . .	154-173
insect enemies, United States, article by F. C. Bishopp . . . . .	383-396
losses from poisonous plants, control studies . . . . .	140
in ocean transit, decrease, cause, etc. . . . .	162
numbers, in principal countries . . . . .	666-672
products, review by Secretary . . . . .	19-20
protection in national forests . . . . .	68
quarantine acts, enforcement, remarks by Secretary . . . . .	34
transportation laws, enforcement, violations, etc. . . . .	251
Loans, costs of making . . . . .	30
farmers', discussion . . . . .	25-30
interest rates to farmers, discussion . . . . .	29
Locust, black, use on dry lands, note . . . . .	123
Logging operators, small, dependence on National control of forests . . . . .	415-416
opportunities afforded by national forests . . . . .	406
use of timber from national forests, article by William B. Greeley . . . . .	405-416
Louisiana, aid for agricultural education in high schools . . . . .	473
requirements for teaching agriculture in high schools . . . . .	473
Lumber, exports . . . . .	729-730, 748-749
imports . . . . .	717, 749-750
industry, relations of Forest Service . . . . .	60-62
kiln-drying, losses, investigations, etc. . . . .	71, 239
mills, by-products from waste . . . . .	239
small, opportunities, in national forests . . . . .	409
operators, eastern, opportunities . . . . .	410
waste, utilization by distillation, etc. . . . .	200
<i>Lyperosia irritans</i> . See Horn fly.	
Macaroni, imports . . . . .	746
Machinery, desiccated milk, descriptions, etc. . . . .	340, 342-344
<i>Macrocystis pyrifera</i> , habitat, area, value, etc. . . . .	533, 534-535
<i>Macrospium granaria</i> , aphid affecting grains . . . . .	398, 402, 403
Magdeburg-Halberstadt region, source of potash . . . . .	523
Maine, aid for agricultural education in high schools . . . . .	472
Major pecan, history and description . . . . .	275
Mallein, preparation and distribution . . . . .	48, 171
Malt liquors, imports . . . . .	721
Malta fever. See Fever, Malta.	
Mammals, importations, 1912, supervision, numbers, etc. . . . .	82-83, 174
native, publications on distribution and habits . . . . .	174-175
Mange, cattle, control work . . . . .	165-166
Mango, oriental, introduction . . . . .	119
Mangoes, dried, note . . . . .	516
Manila, imports . . . . .	742-743
Maple sirup and sugar, investigations by Chemistry Bureau . . . . .	53
Maps, fruit district, note . . . . .	132
weather. See Weather.	
Marine meteorological charts, increase since 1909 . . . . .	183-184
work, Weather Bureau . . . . .	40-41
Marketing cotton, improved methods, etc., article by Charles J. Brand . . . . .	443-462
remarks of Secretary . . . . .	127
dressed poultry, preparation, handling, etc. . . . .	285-293
food products, investigations by Chemistry Bureau . . . . .	50-52, 53
fruits, investigations . . . . .	132-133
perishable products, cooperative system . . . . .	355-358
independent system, losses, various charges, etc. . . . .	353-356
vegetable products, shipping charges, advantages in cooperation . . . . .	355-357
successful methods, article by L. C. Corbett . . . . .	353-362
vegetables, cooperative organizations, business methods . . . . .	360-362
Markets, desiccated milk . . . . .	339
Marmalades, fruit, preparator . . . . .	508
Maryland, aid for agricultural education in high schools . . . . .	473-474
Eastern Shore, muskrat farming, profitable development . . . . .	80-81

	Page.
Massachusetts, aid for agricultural instruction in high schools.....	474
MCATEE, W. L., article on "Relation of birds to grain aphides".....	397-404
Meadow lark, economic importance.....	279-284
<i>See also</i> Lark, meadow.	
larks, relation to agriculture, article by F. E. L. Beal.....	279-284
Meat animals, exports, decrease, causes.....	162
imports.....	714
inspection, Federal, statistics of operations, remarks.....	42-43, 160
law, enforcement, cases, etc.....	252-253
review of laws and work.....	34, 159-160
Meats, freight rates.....	706, 707
Mechanics, farm, instruction in high schools.....	480
Medicines, improvement under pure food law.....	207
Mediterranean fruit fly, damage, quarantine necessity, etc.....	79-80
<i>Megilla maculata</i> , enemy of onion thrips.....	322
<i>Melospiza melodia</i> , enemy of grain aphides.....	401, 402, 403
Merkel, H. W., discoverer of chestnut-bark disease, note.....	363
METCALF, HAVEN, article on "The chestnut-bark disease".....	363-372
Meteorograph, use with kites, by Weather Bureau.....	186
Meteorological charts, scope, preparation, distribution, etc.....	40-41
marine charts, increase since 1909.....	183-184
stations, frost predictions, reports.....	39
Meteorology, higher atmosphere, studies with kites and balloons.....	36
Mexican cotton boll weevil. <i>See</i> Boll weevil.	
Microchemical studies by Chemistry Bureau.....	53-54
Microcline, source of potash, extraction methods, investigations, etc.....	523-530
Midge, sorghum, control.....	122
Milch cows. <i>See</i> Dairy cows.	
Milk, city supplies, inspection and improvement.....	49
condensed and desiccated, article by Levi Wells.....	335-344
<i>See also</i> Condensed milk.	
desiccated. <i>See</i> Desiccated milk.	
desiccating systems.....	341-344
dry. <i>See</i> Desiccated milk.	
flour. <i>See</i> Desiccated milk.	
improvement methods, cooperative studies.....	157
inspection, use and value of score card.....	157
investigations by Chemistry Bureau.....	53
pasteurization in control of abortion bacillus.....	170
powder. <i>See</i> Desiccated milk.	
price, 1912.....	20
production, increase per cow, methods.....	155-156
Mill operators, small, opportunities afforded by national forests.....	406
use of timber from national forests, article by William B. Greeley.....	405-416
Greeley.....	415-416
Millmen, small operators, dependence on National control of forests.....	415-416
MILNER, R. D., and C. F. LANGWORTHY, article on "Some results obtained in studying ripening bananas with the respiration calorimeter".....	293-308
Milo, crop suitable to semiarid region, value and use.....	467
Mineral waters, studies by Chemistry Bureau.....	56
Mining claims, national forests, investigation and settlement.....	65-66
industries, Nevada and California, timber supply from national forests..	408
Mink rearing experiments, value of pelts, and practicability of industry.....	80
Minnesota, aid for agricultural education in high schools.....	472-473
Experiment Station, plant breeding work, results.....	213
Mississippi River flood, cooperative study and report, etc.....	38
effect on cane-sugar industry.....	18
1912, warnings, losses, etc.....	38
Modoc National Forest, timber supply to local operators, output of mills, etc..	408
Molasses, imports.....	742-743
Monocacy apple, history and description, etc.....	263-266
Moon, appearance, relation to weather, folklore, etc.....	378-379
Morgan horses, breeding work, at Middlebury, Vt.....	43, 154
Mortgages, personal property, remarks.....	27
Mosquitoes, control studies, Entomology Bureau.....	148
Moths, gypsy and brown-tail, work of Entomology Bureau.....	75-76, 146-147

	Page.
Mount Weather Bulletin, work, nature of contributions, etc.....	32
Observatory, establishment and work, 1903-1912.....	36, 189-191
school of instruction, establishment, scope, etc..	41-42
Mountain farms, evaporation of moisture, effects of slope.....	312
fruit growing.....	312-318
heat absorption and radiation, effects of slope.....	311-312
nature of slope, importance.....	310-312
regions, air drainage, advantages to fruit growers.....	314-315
slopes, crop safety, article by J. Cecil Alter.....	309-318
longitudinal comparisons, effect on climate.....	311
range of temperature.....	315-318
snowfall measurement, work, progress, and value.....	38-39, 188
Mountains, advantages to agricultural localities, remarks.....	309-310
Mulberry scale, parasite enemy, exportation to Italy by Entomology Bureau..	147
Mules, numbers, in principal countries.....	666-669
values and prices.....	677-680
statistics, numbers, values, and prices.....	678-680
Muskrat farming, development and profits.....	80-81
National Forests. <i>See</i> Forests, National.	
Naval stores, exports.....	729
obtained by distillation of wood.....	71, 200, 238
Nebraska, carbonate ponds, possible source of potash.....	527
Nematode gallworm, control, note.....	123
<i>Nereocystis luetkeana</i> , habitat, area, value, etc.....	533
New England woodlands, improved conditions under insect control.....	75
York, aid for agricultural instruction in high schools.....	474
gypsy moth appearance and control work.....	75
Nicotine-sulphate sprays for onion thrips, formulas, results, etc.....	323-324, 325
Niter, artificial. <i>See</i> Potassium nitrate.	
Nitrogen cultures, distribution to farmers, efficiency, etc.....	139
fixing bacteria, inoculation of soil.....	139
Nodule-forming bacteria, distribution and use.....	139
Norfolk fine sand, area and importance in trucking, etc.....	422-423
sandy loam, area and importance.....	422-423
sand, area, importance in trucking, etc.....	423-424
sandy loam, description, importance in production of early vegetables.....	422
North Carolina trucking districts, Atlantic coast, area and production.....	430-431
Dakota, aid for agricultural instruction in high schools.....	475
Northern Hemisphere, atmospheric conditions, study, extension of work, etc..	37
Nursery, cover crops, note.....	124
stocks, chestnut, inspection for bark disease.....	369
forest, diseases, control studies and experiments.....	137
Nut culture, investigations.....	133
disease, control work.....	138
Nutrition investigations, Experiment Stations Office.....	109-110, 221-228
plant, investigations.....	139
problems, assistance by Department.....	223-224
publications, demand, work, etc.....	222-223
Nuts, imports.....	722
Oak, cork, introduction, note.....	120
OAKLEY, R. A., article on "Some new grasses for the South".....	495-504
Oaks, danger of chestnut bark disease, note.....	367
Oats, acreage and production, principal countries.....	580-582
production, farm value, prices and exports.....	14, 583-588
hay crop for Northern Great Plains.....	467
losses from green bug, 1907.....	397
prices, farm and wholesale.....	20, 21, 583, 586-588
statistics, acreage, production, farm value, yield, prices, exports, etc..	580-588
"sulphuring," study.....	135
winter, note.....	122
Object-lesson roads, remarks by Secretary.....	111
Observatory, Mount Weather, establishment and work, 1903-1912.....	189-191
Observers, cooperative, work with Weather Bureau, extension.....	184
Ocean forecasting, work and methods of Weather Bureau.....	40-41, 178, 183-184



	Page.
Ocean freight rates.....	709
<i>Oestrus ovis</i> , injuries to sheep, habits, and measures for control.....	389
<i>See also</i> Sheep bot.	
Office. <i>See</i> Experiment Stations Office, Roads, Public, Office; Solicitor, Office.	
Oil cake, exports.....	733
statistics, international trade.....	661
cottonseed, exports.....	733
international trade.....	624-625
mill, cottonseed, cooperative, at Glendora, Miss., advantages.....	445
plants, studies.....	140
Oils, exports.....	740-741
vegetable, imports.....	722-723
Oleo oil, exports, remarks.....	22
Olive oil, imports.....	722, 744-745
Olives, dried, source and uses.....	516
Onion fields, treatment for thrips.....	323-326
fly, barred-winged, damage to crop, description, and remedies.....	329-332
black, damage to onion crop, description, habits, and remedies...	329, 332
growing, increase of industry.....	319
louse. <i>See</i> Onion thrips.	
maggot, imported, damage to onion crop, description, habits, etc.....	328-329
thrips, control measures, description, habits, etc.....	79, 322-326
enemies.....	322-323
food plants.....	321-322
Onions, imports.....	745
stored, treatment for onion black fly.....	329
Opium, imports.....	744-745
Orange peel, crystallized, uses, note.....	513
thrips, spraying for control, California.....	78
Oranges, exports.....	731
imports.....	719, 746
storage with bananas, studies.....	295
Orchards, mountain, advantages.....	312-318
planting, nursery stocks and cover crops, notes.....	124
Oregon, prune-producing region, importance.....	510
Ormond persimmon, history and description.....	270-271
Ornamental plants subject to injuries from onion thrips.....	321
Orthoclase, source of potash, extraction methods, investigations, etc.....	528-530
Owens Lake, potash deposits, note.....	532
pecan, history and description.....	275-276
Ox botfly, pest of cattle, manner of infection, control, etc.....	388-389
louse, pest of live stock, control.....	395
Oysters, adulteration, investigations, Chemistry Bureau.....	205
Pacific Coast, freight rates.....	710
Packing-house products, exports.....	726-728, 737-739
Palm oil, imports.....	722
Panama Canal, relation to seed supply.....	10
Paper making, investigations by Chemistry Bureau.....	57, 199-200
Paralysis, infantile, conveyance by insects, note.....	78
Parasite, alfalfa weevil, introduction, value, etc.....	147, 148
mulberry scale, exportation from United States to Italy.....	147
Parasites, animal, studies by zoological division, Bureau of Animal Industry..	172
beneficial, introduction, value, etc.....	147-148
Parasitic diseases, animal, studies.....	172
Passburg system, desiccating milk.....	344
<i>Passerculus sandwichensis savanna</i> , enemy of grain-aphides.....	400, 402, 403
Pasteurization, milk and cream, advantages.....	50
Pasturage, dairy cattle in semiarid regions.....	468
Patten Greening apple, development, note.....	262
Peach diseases, control work.....	137, 138
leather, process of making.....	511
stock, hardy Chinese, introduction.....	119
Peaches, dried, consumption in United States, 1909.....	510
drying, effect of sulphur fumes.....	508
processes.....	511

	Page.
Peanut investigations, remarks.....	131
Peanut-oil industry, remarks.....	131-132
Pear blight, control work.....	137
Douglas, history and description.....	267-268
thrips, control work by Entomology Bureau.....	79, 147
Pears, drying processes.....	510
Peas, Canadian field, crop for northern Colorado.....	467
early crop in California, destruction by meadow lark.....	280
growing in Charleston trucking district.....	429
improvement by pure-culture inoculation.....	139
statistics, acreage and production.....	646-647
Pecan scab, control work.....	138
Pecans, new varieties, description, nomenclature, etc.....	273-278
Peel, lemon and orange, uses.....	513
<i>Pegomya</i> , spp., damage to onions, notes.....	326, 327
Pellagra, conveyance by insects, investigations.....	78
transmission by stable fly, note.....	391
PENNINGTON, M. E., article on "The handling of dressed poultry a thousand miles from the market".....	285-292
Pennsylvania Chestnut-tree Blight Commission, work, note.....	368
Pepper growing, work.....	139
Perfumery plants, studies.....	140
Persimmon, Chinese, introduction, note.....	120
Ormond, history and description.....	270-271
Persimmons, dried, note.....	516
Japanese, processing to render nonastringent.....	52
Personnel, Agriculture Department, 1912.....	31
Phosphate rock, supply in United States.....	153
smelter waste, utilization as fertilizer.....	198
<i>Phytonomus posticus</i> . See Alfalfa weevil.	
Picking poultry for market, processed.....	287-288
PIERCE, H. C., article on "How the produce dealer may improve the quality of poultry and eggs".....	345-352
Pike National Forest, timber supply to local operators.....	408
Pine seed, number to pound, amount to bushel of cones, etc.....	434
seeds, gathering the cones, management.....	435-437
siskin, enemy of grain aphides.....	399, 402, 403
trees, Europe, quarantine.....	247
western yellow, seed collection, Kaniksu National Forest.....	437-442
Pineapple industry, Hawaii, development, aid of experiment station, etc.....	219
Pioneer, professional, factor in development of irrigated lands.....	485-486
Pistache nut, introduction.....	119
Plague, bubonic, spread by rodents.....	81
Plant breeding work, development in 16 years.....	213-214
composition, effect of environment, studies, Chemistry Bureau.....	197
Industry, Bureau, organization and growth, review by Secretary.....	117-144
inspection and quarantine work.....	77-78
pathology, problems and study.....	136-139
physiology, investigations and work.....	54, 139-140
quarantine law, object and administration.....	247, 254
Plants, drug, studies.....	139-140
Hawaiian, quarantine notice.....	247
oil and perfumery, studies.....	140
poisonous, studies.....	140, 170
"Plated" cotton bales, note.....	461
Pleuropneumonia, control work.....	163
Plum leather, processes of making.....	511
Plumage hunting, efforts to control.....	84
Plums, drying, processes.....	510-511
imports.....	745
Poison baits, for cutworms, formula, application, etc.....	332, 333
destruction of ground squirrels and other rodents.....	81
Poisoning, horse, by forage, control methods.....	170
Poisonous plants, studies.....	140, 170
Pollock avocado, history and description.....	272
Pomace, grape, from wine presses, possible source of potash salts.....	526

	Page.
Pomology, progress.....	132
<i>Poecetes gramineus</i> , enemy of grain aphides.....	399-400
Poplars, dry land, introduction and use.....	120, 123
Pork, exports.....	727-728, 738-739
Porto Rico Experiment Station, development and work, remarks by Secretary.....	105-106, 219-220
Portsmouth soils, descriptions, treatment, value for trucking, etc.....	426-428
Potash extraction methods, fertilizer manufacture.....	528-531
possible sources in United States, article by Frank K. Cameron.....	523-536
salts, American sources, investigations authorized by Congress.....	524
silicates, potash content, and extraction methods, investigations.....	528
sources, investigations.....	10, 73, 524
Potassium nitrate, imports, uses, remarks.....	526
sulphide spray, for control of cotton red spider.....	79
Potato growing in Wilmington trucking district.....	430
on Portsmouth sandy loam, yields, quality, etc.....	427
wilt, control work.....	138
Potatoes, crop, 1912, remarks.....	15
diseases, cause, control work, etc.....	136
early production for market, Norfolk trucking district.....	425, 429, 431
imports.....	744-745
improvement by breeding and introduction of new kinds.....	131
prices, farm and wholesale.....	20, 21, 610-613
production, principal countries.....	607-608
quarantine notice.....	247
statistics, acreage, production, farm value, yield, prices, exports, etc.....	15, 607-613
sweet. <i>See</i> Sweet potatoes.	
Poultry, breeding stock furnished by dealer, practices, results, etc.....	349
buying on quality basis by dealer, discussion.....	345-347
danger from turkey gnat.....	385-386
dealer, improvement of poultry, article by H. C. Pierce.....	345-352
drawing before marketing, suggestions.....	287-288
dressed, cars for shipping, capacity, equipment, loading, etc.....	290-292
grading and packing for market.....	289-290
handling a thousand miles from the market, article by M. E. Pennington.....	285-292
marketing methods, history.....	285
shipping methods.....	290-292
dressing for market, methods.....	286-289
education regarding, means of obtaining.....	347-348
feeding preparatory to killing for market.....	286
improvement by produce dealer, etc., article by H. C. Pierce.....	345-352
industry, 1912, remarks by Secretary.....	19, 44, 50-52
killing for market, processes.....	287-288
losses between producer and consumer, annual.....	345
marketing, use of carton, value, etc.....	290
picking, processes.....	287-288
price, 1912.....	20
shippers' associations, aid in improvement of products, suggestions.....	351
shows, aid in improving quality of poultry and eggs.....	348
starving before killing for market.....	286
Preservatives, chemical, in food, restrictions.....	245
Prices, cattle.....	683
farm products, comparison for recent years.....	20-22
horses and mules.....	679-680
statistics, principal crops.....	562-564,
569, 570, 573-576, 583, 586-588, 592-596, 600, 602-604, 605, 606, 610, 613-	
617, 622-624, 627-629, 630-635, 637-639, 640, 645, 652-653, 656, 658-660	
Printing and binding for department, estimate.....	86
Produce dealers, improvement of poultry, article by H. C. Pierce.....	345-352
Props, round, for coal mines, supply from Bear-tooth National Forest.....	408
Provisions, freight rates.....	709
Prunello, description, importation and use.....	511
Prune-producing regions of world, important.....	510
Prunes, consumption in United States, 1909.....	510

	Page.
Prunes, exports.....	23, 731
imports.....	745
laxative properties.....	519
Publications, Agriculture Department, increase in numbers and usefulness..	115-117
sale by Superintendent of Documents.....	88-89
distribution.....	116-117
Division, review of work by Secretary.....	87-90, 115-117
educational use.....	89
handling, distribution, demand, etc.....	88-90
limit of editions, remarks.....	89
nutrition, demand, work, etc.....	222-223
poultry industry, help to farmers, etc.....	348, 350-351
scientific and technical, suggestions.....	89-90
Solicitor's office, remarks by Secretary.....	35-36
Statistics Bureau, increase since 1897.....	195
Weather Bureau, kind, number, and scope.....	185, 249
Pulp, wood, new sources, increased consumption, etc.....	238
<i>See also</i> Wood pulp.	
Pure food law. <i>See</i> Food and Drugs Act; Law, pure food.	
Pyrheliometer, improved type, development and use, Weather observatories.	41, 186
Quarantine, animal, enforcement, violations, etc.....	34, 48, 249-250
animals, export and import.....	48
cattle scabies, establishment, area released, etc.....	165-166
tick, area released.....	45
insects, law, enactment.....	145
plant, law, enforcement by Federal Horticultural Board.....	247
object and administration.....	77, 247, 254
scabies of cattle and sheep, area released.....	45, 165
sheep scabies, establishment, area released, etc.....	45, 165
stations, animal, location, review of work.....	160-161
Quebracho, imports.....	717
Rabbits, European, pests of bird reservations, control, studies, etc.....	84
Rabies, control studies and experiments.....	47, 170
Radiotelegraph, use in weather forecasting.....	178-179
Radiotelegraphic communications, reports from sea vessels.....	37
Conference, International, London, remarks on.....	37
Railroad companies, promotion of agriculture, investigations.....	93
ties, timber from national forests.....	408
Railroads, efforts to promote agriculture.....	711
Railways, tonnage carried, 1907-1911.....	703
Rainfall, 1912, notes.....	546, 547, 548, 549, 550, 551, 552, 553, 554, 555, 556
Raisin, Chinese, use in America, note.....	516
district, Fresno, timber used in trays.....	408
seeds, oil production, commercial value.....	140
Raisins, exports, note.....	512
remarks.....	23
figs, and other dried fruits and their use, article by C. F. Langworthy.....	505-522
imports.....	745
production in United States, 1899, 1909.....	512
Sultana, varieties of grapes, preparation, etc.....	511, 512
varieties of grapes used, preparation, etc.....	511-512
Ranchers, national forest region, winter employment.....	412-413
Range management, national forests, development of present system...	241-242, 255
progress.....	68-69
Raspberries, drying with maple sugar.....	512
Recommendations by Secretary.....	46, 64, 66, 70, 89, 90
Red clover, investigations in seed handling.....	121
Referee board, personnel, duties, etc.....	243-244
Reforestation, magnitude of work, seed collection, etc.....	67-68, 434
Refrigeration, cars for dressed poultry.....	291-292
poultry and eggs, studies by Chemistry Bureau.....	51-52
Reindeer, numbers, in principal countries.....	670-672
Renovated butter. <i>See</i> Butter, renovated.	
Reservations, bird and game.....	83-85

Respiration calorimeter, uses and value.....	222
Rhodes grass, culture, climatic requirements, localities suitable, etc.....	497-499
history, introduction into United States, value, etc.....	496-499
introduction, note.....	121
Rice, acreage, production, value, prices, and trade.....	16, 635-639
coating, prohibition.....	245
exports.....	740-741
farmers, aid by department.....	118
growing and breeding, Hawaii, experiments.....	219
extension under irrigation, production, value, etc.....	225
imports.....	723, 744-745
international trade.....	639
prices, farm and wholesale.....	20, 21, 637-639
production, principal countries.....	635-637
statistics, acreage, production, value, prices, etc.....	635-639
Right of way, reservation by Government in homestead entries.....	64-65
Ripening bananas, experiments with respiration calorimeter.....	293-308
RISSEr, A. K., article on "Dairying and its relation to agriculture in semiarid sections".....	463-470
River service, Weather Bureau, extension since 1897, remarks by Secretary..	182-183
Rivers and floods, work of Weather Bureau.....	38-39
Road building, bond issues, investigations.....	113
lectures, exhibits, road-improvement trains, etc.....	113-114
Inquiry Office, establishment and development of work.....	208
materials, testing, work, standard, methods, etc.....	112-113, 208-209
Roads, experimental, work of Roads Office, 1912.....	111
mileage and cost, United States, investigations.....	113, 211
model, systems, development, work.....	111
models of types, exhibits, educational value.....	209
object-lesson, construction, etc.....	111, 207-208
post, appropriation, direction of work by department.....	207, 248
Public, Office, development in 16 years, review.....	207-211
review of work by Secretary.....	110-114
Rock phosphates, United States supply.....	153
salt, deposits, source of potash, discussion.....	527
Rocky Mountains, farming, remarks.....	309-310
Rodents, control experiments.....	81
Root maggots, damage to onion crop, descriptions, ranges, remedies, etc....	326-332
rot, sugar beets, control work.....	139
tobacco, control work.....	138-139
Roses, use as perfumery plants, studies.....	140
Rosin, exports.....	729, 748-749
statistics, international trade.....	661-662
Roundworm, transmission by stable fly.....	391
Rubber gums, imports.....	749-750
india, imports.....	717, 749-750
statistics, international trade.....	663
Rum, exports.....	732
Rust, asparagus, control.....	138
Rye, acreage and production, principal countries.....	597-599
production, farm value, prices, and exports.....	16, 600-604
prices, farm and wholesale.....	20, 600, 602-604
statistics, acreage, production, farm value, yield, prices, exports, etc....	597-604
Saccharin in foods, prohibition.....	245
Salmon-packing industry, timber supplies from Alaskan national forests.....	408
Salt Lake Valley, fruit growing, advantages of the mountain shade.....	313
mines, Germany, supply of potash salts.....	523
supplies, monopolies by European Governments as means of revenue, note..	523
wells, source of potash, discussion.....	527
Salton Sea, evaporation studies, 1907-1909, results.....	187
San Antonio field station, work, notes.....	122
Jose scale, history, control, etc.....	145-146
Savanna sparrow, enemy of grain aphides, examination of stomach.....	400, 402, 403
Sawdust, possible source of potassium carbonate.....	524-525
Scab, pecan, control.....	138

	Page.
Scabies, cattle, control work.....	45, 164-166
sheep, control work.....	45, 164-165
Scale, black, orange and olive, parasite enemy, introduction.....	147
insects, control by fumigation, improved methods.....	79
mulberry, parasite enemy, exportation to Italy by Entomology Bureau.....	147
San Jose, history, control, etc.....	145-146
School lands, exchange in various States for forest lands.....	65
Schools, agricultural, growth, extent, and number.....	101-102
in United States list.....	476
State aid for high schools, management.....	472-475
high, agricultural instruction, character.....	476-481
number and distribution.....	475-476
equipment for teaching agriculture in Louisiana.....	473
Kansas, requirements for State aid in agricultural instruction... ..	474
Maryland, requirement for State aid in agricultural instruction.....	474
Massachusetts, requirements for State aid.....	474
New York, requirements for State aid.....	474
North Dakota, requirements for State aid.....	475
public high, agricultural education, article by Dick J. Crosby.....	471-482
secondary, types teaching agriculture.....	471-472
teaching agriculture, lists, 1897 and 1912.....	215
Scientific publications, remarks.....	89
SCOFIELD, CARL S., article on "The settlement of irrigated lands".....	483-494
Score card, milk, use and value in improvement of milk supplies.....	49, 157
Screw worm, injuries to live stock, occurrence, control measures, etc.....	392-394
Scullions, onion, cause, note.....	320
Searles Marsh, potash deposits, withdrawal from entry, etc.....	532
Seasons, folklore, explanations.....	374
Secretary, Agriculture. <i>See</i> Agriculture Secretary.	
Seed, beet, production, remarks.....	135
clover, prices.....	617-618
collection on a large scale, article by Henry H. Farquhar.....	433-442
congressional distribution, number and kinds of packages.....	134
corn, breeding and selection.....	128
cotton. <i>See</i> Cotton seed.	
crop, forest trees, foretelling the crop, factors to be considered.....	435
distribution, policy, and methods, remarks by Secretary.....	133-134
forest, amount collected in United States.....	433
average cost for collection and from dealers.....	434-435
collecting and extracting, methods and cost.....	68
collection, advantages of wholesale operations.....	434-435
organization of collectors' camps.....	438-439
cost of collection on Kaniksu National Forest, 1911, items.....	441-442
purchase by Forest Service.....	433
importation, act of Congress, note.....	130
pure, provision for farmers.....	130
red clover, handling methods, note.....	121
reforesting denuded lands, quantity required per acre.....	433
relation of Panama Canal to supply.....	10
Rhodes grass, description.....	497
Sudan grass, resemblance to Johnson grass seed, caution.....	503-504
testing, laboratory work.....	130
timothy, prices.....	617-618
tobacco, selection for improvement.....	129
Seed-corn maggot, damage to onion crop.....	327
Seed-cotton, storage on farm, benefits, suggestions, etc.....	449-450
Seeding habits, Rhodes grass.....	497-498, 502
Seedlings, forest-tree, damping-off, control work.....	137
Seeds, dry-farming, distribution, note.....	134
imports.....	723
Seepage, disposal in irrigated lands.....	227
Semi-arid sections, dairying and its relation to agriculture, article by A. K. Risser.....	463-470
Sera, use in glanders diagnosis, distribution.....	171
Serum, hog cholera, experiments, manufacture, distribution by States, etc.....	46-47, 169
Settlement, irrigated lands, article by Carl S. Scofield.....	483-494

	Page.
Settlers, aid from promoters of irrigation project, discussion	488-489
benefits from proximity of national forests	412-413
irrigated lands, community action and relationships	490-491
need of conveniences	490
need in national forests	64
Shama thrush, popularity	83
Sheep bot, injuries to sheep, habits, and control measures	389
breeding, work of department	44
damage by poisonous plants	170
danger from dogs	10
effects of sheep bot, remedies, etc.	389
exports	726
grazing, national forests, 1905 to 1912	242
husbandry, studies	155
imports	712
losses from eating poisonous plants, control studies	170
numbers, in principal countries	666-669
scabies eradication, progress	45, 164-166
statistics, number, value, and prices	691-694
United States, number, value, and prices	691-694
<i>See also</i> Live stock.	
Shellac, candy adulteration	245
imports	749-750
Shellfish industry, investigations by Chemistry Bureau	205
Ship. <i>See</i> Vessel.	
Shipping cotton, cost, value of gin compresses, etc.	456-457
vegetables to market, advantages in cooperation	355-357
mixed cars, management	356
Shorthorn cattle breeding, increase of milk supply, remarks	44
Siberia, plants, introduction	120
Sierra National Forest, timber supply for trays in grape-growing district	408
Silicates, potash bearing, location	528-531
Silk, imports	713, 741-742
statistics, production	664
Silo, importance in semiarid regions	469
Silos, concrete, studies	156
Silver top, onion, cause, appearance, etc.	320
<i>Simulium meridionale</i> . <i>See</i> Turkey gnat.	
<i>pecuarum</i> . <i>See</i> Buffalo gnat.	
<i>Siphocoryne avenæ</i> , aphid affecting grains	398, 402, 403
Sirups, investigations by Chemistry Bureau	18, 53, 198
Sisal grass, imports	744-745
Skins, exports	727
imports	714, 746
international trade	673-677
mink, value, etc.	80
Sky colors, weather folklore, explanations	376-377
Slaughterhouses, treatment of wool washings to preserve potash salts	526
Smelter fumes, condensation and utilization as fertilizer	198
Snow, 1912, notes	546, 547, 548, 549, 550, 553, 555, 556
survey work, importance to irrigation farmer	188
Snowbird, enemy of grain aphides, examination of stomach	401, 403
Snowfall, mountain, measurement, work, progress	38-39, 188
Soap, use in sprays for onion thrips, function, suggestions, etc.	324
Soil, bacteriology, investigations	139
cabbage, description	422-423
chemistry investigations	72-73
conservation, note	11
exhaustion, possibility, causes, etc., remarks by Secretary	150-151
fertility, investigations by Soils Bureau	74-75
investigations, review for 16 years	150-153
physics, study and investigations for soil improvement	72-73
semiarid regions, improvement, relation of live stock	464
surveys, work, areas, etc., review by Secretary	71-72, 151
types, relation to crop rotation, note	152-153
Soils, adaptation to various crops, studies, remarks by Secretary	151-152

	Page.
Soils, Bureau, work, review by Secretary.....	71-75, 150-153
Coxville series, descriptions, value in trucking, etc.....	424-426
national forests, classification, cooperation of Soils Bureau.....	64, 72
Norfolk series, descriptions.....	422-424
"sick," Porto Rico, studies.....	220
tobacco, improvement, notes.....	129
truck, Atlantic coast region, article by Jay A. Boustedt.....	417-432
Solar radiation, investigation and equipment, Weather Bureau.....	41, 186, 191
Solicitor, office, review of work by Secretary.....	32-36, 248-258
Song sparrow, enemy of grain aphides, examination of stomach.....	401, 402, 403
<i>Sorghum halepensis virgatus</i> . See Tunis grass.	
midge, control, note.....	122
relation to dry-land problem.....	10
sirup, investigations by Chemistry Bureau.....	53
Sudan grass. See Sudan grass.	
Sorghums, investigations and new varieties.....	121, 122
suitability to semiarid regions, value and use.....	467
South, beef production, notes.....	155
Carolina trucking districts, Atlantic coast, area and production.....	429-430
corn-growing experimental work.....	142
dairy farming introduction.....	156
Dakota Experiment Station, plant-breeding work, results.....	213
school lands, exchange for forest lands.....	65
fever-tick eradication.....	9
new grasses, article by R. A. Oakley.....	495-504
Soy beans, new varieties, introduction.....	121
Sparrows, enemies of grain aphides, examination of stomachs.....	399-401, 402, 403
Spices, imports.....	723
Spider, red, cotton, area infected and control experiments, methods, and cost.....	431
Spinach growing in Norfolk trucking district.....	79
<i>Spinus pinus</i> , enemy of grain aphides.....	399
<i>Spizella</i> spp., enemies of grain aphides.....	400, 402, 403
Sprayers, onion, illustrations.....	326
Spraying apple and peach, for diseases and insects.....	137-138
demonstrations, value in fruit pathological work.....	137-138
insects affecting citrus fruits, experiments.....	78
injurious, demonstrations and experiments.....	78, 79, 137-138, 147
machines for onion thrips, illustrations.....	326
pecan scab.....	138
thrips, demonstrations and experiments.....	78, 79, 147, 323-326
vegetable crops, demonstrations and experiments.....	138
Sprays, solutions for onion thrips.....	323-324
Springs, mineral, studies by Chemistry Bureau.....	56
Squirrels, caches of forest seeds, aid to collectors.....	436
ground, California, destructiveness, danger, and control.....	81
St. John's bread, dried, use, note.....	516
Stable fly, control measures.....	392
description, habits, history, damage to live stock, etc.....	391-392
transmission of disease to man and live stock.....	78, 391-392
Stars, relation of appearance to weather conditions, folklore, etc.....	379-380
Statistics Bureau, field agents and correspondents, number, etc.....	192, 194
work, review by Secretary.....	90-95, 191-196
crop, with prices, etc.....	557-654
Farmers' Institutes, number, attendance, and cost.....	215-216
roads, study by Roads Office.....	211
Stauf process, desiccating milk.....	343
Stock cultures, animal-disease producing, supply to scientists.....	172
See also Live stock.	
Stomach worm, horses, transmission, control studies.....	172
sheep, control studies.....	172
<i>Stomoxys calcitrans</i> . See Stable fly.	
Storage, cold, investigations.....	92
cotton seed, benefits, suggestions, etc.....	449-450
fruit, investigations.....	133
Store credit for farmers.....	23
Storm warnings, distribution, extension since 1896.....	180-181



	Page.
Storms, notes, 1912.....	546, 547, 548, 553, 554, 555
radiotelegraphic warnings, remarks by Secretary.....	37, 178-179
tropical, warnings by Weather Bureau.....	37, 179
Stassfurt potash salts deposits, supply of United States.....	523-524
Strawberries, growing in Norfolk trucking district.....	431
Strawberry, Chesapeake, history and description.....	269
growing, Atlantic coast region, soil suitable.....	425, 427-428
Stream flow, relation to forest cover, studies.....	39
<i>Sturnella</i> spp. See Lark, meadow.	
Sudan grass, adaptability to various conditions.....	503
growing experiments.....	121
hybridizing with sweet sorghums.....	504
introduction, growth habits, cultural methods, possibilities.....	121, 499-504
Sugar, beet, increase in production in 1912.....	17
industry development, aid of department.....	135-136
beets, diseases, control work.....	139
See also Beets.	
exports.....	734-735, 740-741
imports.....	724, 744-745
international trade.....	654
investigations by Chemistry Bureau.....	53
prices.....	20, 652-653
production in 1912, remarks.....	17
principal countries.....	648-649
statistics, production, prices and trade.....	648-654
"Suint," composition, source of potash salts.....	525-526
Sulphate, copper, use in foods, prohibition.....	245
purification of water, experiments.....	139
"Sultanas," variety of grapes used, preparation, etc.....	511-512
Summer King apple, history and description.....	266-267
Sun, folklore in relation to weather conditions, explanations, etc.....	375
Sunflowers, source of potash in Russia.....	526
Supplies, examination by contracts laboratory, Chemistry Bureau.....	57, 201
Surra, introduction into United States, control methods.....	161
transmission by stable fly, note.....	391
Surveys, farm management, cooperative studies.....	143
soil. See Soil surveys.	
Swamp fever, horses, study, remarks.....	170
Sweet potatoes, diseases, control studies, and work.....	138
growing in Charleston trucking district.....	429
investigations, uses, storage, etc.....	131
Swine. See Hogs.	
<i>Tabanus</i> spp., injury to live stock.....	386
Tahoe National Forest, timber supply to local operators.....	408
Tallow, exports.....	727
Tanning materials, imports.....	717-718
Tapeworms as parasites, studies.....	172
Tar, use on diseased chestnut trees.....	370
Tare, cotton, practices and standardization.....	458-460
TAYLOR, WILLIAM A., and H. P. GOULD, article on "Promising new fruits".....	261-278
Tea, coloring and facing, determination method, adoption.....	54
growing, work, remarks by Secretary.....	139
imports.....	724, 744-745
production in United States, quantity, etc.....	139
statistics, trade, and prices.....	655-656
Teacher, agriculture in high schools of Louisiana, requirements.....	473
Technical publications, remarks.....	89
Telegraph, wireless. See Radiotelegraph.	
Temperature conditions, studies, publication in Mount Weather Bulletin.....	36
Tenants, loans, remarks.....	27
Texas, aid for agricultural instruction in high schools.....	475
fever, eradication work, review by Secretary.....	163-164
"Thick-neck" onion, cause, note.....	320
Thrips, onion. See Onion thrips.	
orange, control investigations and work in California.....	78

	Page.
Thrips, pear, control, work of Entomology Bureau.....	79, 147
<i>tabaci</i> . See Onion thrips.	
Thrush, shama, substitute for mocking bird, popularity.....	83
Tick, cattle, cause, control, etc., scientific studies.....	167
eradication work.....	163-164
quarantine area released.....	45, 164
fever, Rocky Mountain, control, investigations.....	78
varieties, control studies.....	148
Timber consumption, annual.....	232
cut, national forests.....	58-59
exports.....	730, 748-749
free use national forests, 1912, by States.....	59
industries peculiar to certain regions.....	408
National Forests, annual supply to local operators.....	407
for the small operator, article by William B. Greeley.....	405-416
free use by farmers.....	412
sales under new law.....	414-415
sales, national forests, 1905 and 1912, amount and value.....	242
regulations, etc.....	58-62, 413-414
stand, national forests.....	58-66
United States, and annual growth.....	232
trespass cases, national forests, work of Solicitor's Office.....	255, 257
Timbers, hand-worked, opportunities for small operators.....	411
strength, investigations.....	238
Timothy, breeding, note by Secretary.....	121
seed, prices.....	617-618
Tin salts in canned goods, prohibition.....	245
Titlark, enemy of grain aphides, examination of stomach.....	401, 402, 403
Tobacco, acreage, production, farm value, yield, prices, and trade.....	15, 625-630
curing and fermenting, study.....	129
diseases, control work.....	136, 138-139
exports.....	735
growing, relation of hay growing.....	129
imports.....	724
industry, Hawaii, development.....	219
international trade.....	630
investigations, remarks by Secretary.....	128-129
prices, farm and wholesale.....	20, 21, 627-629
production, principal countries.....	625-627
statistics, acreage, production, farm value, yield, prices, and trade.....	625-630
type improvement, value of soil adaptation studies.....	152
varieties, introduction.....	129
wilt, cause, control work, etc.....	136
Toiyabe National Forest, timber supply for mining operations.....	408
Tomato products, investigations by Chemistry Bureau.....	53-54
Tomatoes, disease, cause, control work, etc.....	136, 138
Towers, steel, for storm warnings, use by Weather Bureau.....	186
Toxoptera, food of birds, examination of stomachs.....	398-404
<i>graminum</i> , outbreaks, description, losses, etc.....	397
Trade balance, maintenance.....	24
Transportation, food-products investigations, by Chemistry Bureau.....	51-52, 53
fruit, investigations.....	133
poultry, dressed.....	290-292
statistics.....	703-711
trucking district, Atlantic coast region.....	417-420
Tray, fruit, industry, timber supply to Fresno raisin district.....	408
Treasury Department, cooperation with Agriculture Department in supervision of bird and animal importations.....	173-174
Tree medication for chestnut-bark disease, experiments.....	368
seed, collection on a large scale, article by Henry H. Farquhar.....	433-442
wounds, painting with coal tar.....	370
Trees, citrus, diseases, cause.....	136
fumigation, value.....	148
coniferous, injury by bark beetles, control work.....	148-149
shade and ornamental, diseases, control studies.....	137
Trespass cases, fire, work of Solicitor's Office.....	257

	Page.
Trespasses, national forests, prosecution, remarks by Secretary.....	254-255, 257
Trinity National Forest, timber supply for mining operations.....	408
<i>Triphleps insidiosus</i> , enemy to onion thrips.....	322
<i>Tritoxa flexa</i> , damage to onion crop, description, etc.....	329, 332
Tropical fruits, propagation methods, study, Hawaii.....	219
storms, warnings to vessels by wireless, value, etc.....	37
Truck crops, diseases, cause, control work, etc.....	138-139
South Atlantic region.....	429-430
growers, special forecasts for.....	39
growing, South Atlantic districts.....	430-431
soils of the Atlantic coast region, article by Jay A. Bonsteel.....	417-432
Trucking district, Atlantic coast, climatic conditions and transportation... ..	417-420
region, descriptions, areas, production, etc.....	428-432
industry, growth.....	420-421
lands, Atlantic coast region, requirements for development, etc... ..	431-432
opportunities, South Atlantic coast region.....	429, 431
Tubercle bacilli, studies.....	168
Tuberculin, distribution by department, results.....	48, 171
tests, effect on animals.....	46, 166
Tuberculosis, animal, scientific studies.....	163
bovine. <i>See</i> Tuberculosis, cattle.....	
cattle, control studies.....	45-46, 166-167
decrease in District of Columbia, Virginia, and Maryland.....	46
Tunis grass, introduction, growth habits, possibilities, etc.....	499-500, 501
Turkey gnat, injury to poultry.....	385-386
life history, habits, and control measures.....	385-386
Turkeys, danger from turkey gnat.....	385-386
Turpentine, distillation, etc., laboratory studies at Madison, Wis.....	71
exports.....	729, 748-749
investigations, Chemistry Bureau.....	57
recovery by distillation of lumber waste.....	200
statistics, international trade.....	662
yields and sources, enlargement, investigations.....	238
Twenty-eight hour law, violation, enforcement, etc., work of Solicitor.....	34, 251
Umatilla Experiment Farm, work.....	124
Utah, canyon winds, menace to agriculture, remarks.....	317-318
Mapleton, cherry orchard, location as to canyon air currents.....	317
Marysville, alunite deposit, yield, source of potash, etc.....	528
mountain regions, climatic variations, relation to fruit growing.....	314-318
Vaccination, cattle, for tuberculosis control, dangers.....	45-46
Vaccine, blackleg, distribution.....	167-168
preparation and distribution by Animal Industry Bureau.....	47-48
Vegetable products, marketing, successful method, article by L. C. Corbett.. ..	353-362
new brands, disadvantages in market.....	355
regulation of market prices, value of cooperation.....	357-358
Vegetables, early production, soils suitable.....	421-424
subject to injuries from onion thrips.....	321, 322
Vermicelli, imports.....	746
Vesper sparrow, enemy of grain aphides, examination of stomachs.....	399-400
Vessel, ocean, animal-carrying, inspection regulations, number inspected, etc.....	162
reporting service, Weather Bureau, location, scope, work, etc.....	40-41
stations, Weather Bureau.....	184
Vetch, improvement by pure-culture inoculation.....	139
use as nursery cover crops.....	124
Vinasse, waste from sugar mills, possible source of potash salts.....	526
Virginia, aid for agricultural education in high schools.....	472
trucking districts, Atlantic coast, area and production.....	431
Viticulture, study, note.....	133
Wages, farm, investigations.....	93
Walnuts, imports.....	746
War Department, cooperation with other departments in Mississippi flood report.....	33
Warehouse receipts, remarks.....	27
Warnings, Weather Bureau, scope, value, etc.....	36-37

	Page.
Warrick pecan, history and description.....	276-277
Wastes, lumber mills, by-products.....	200, 239
oil-producing, investigations.....	140
Water, mineral springs, studies by Chemistry Bureau.....	56
purification, use and value of copper sulphate.....	139
soil, supply, and movement, study by Soils Bureau.....	74
supplies, city and farm, improvement, experiments, and methods.....	139
waste in irrigation, reform work.....	225
"Water-packed" cotton, cause, sources, etc.....	461
Waters, commercial, investigations by Chemistry Bureau.....	55-56
Watersheds, deforestation, relation to floods, study by Weather Bureau.....	187
protection, cooperation of Forest Service with States, etc.....	69-70
purchase for forest lands, examination, cost, etc.....	248, 257-258
Weather Bureau, apparatus, new, installation.....	41
development in sixteen years, review by Secretary.....	176-191
investigation and research.....	36
publications, nature and annual issue.....	184
stations, observations and reports, number for year, etc.....	36-39
work of year, discussion.....	36-42
conditions, 1912, review.....	546-556
forecasts, for year 1911-12, list.....	37
number of persons receiving.....	39-40
map, commercial, history, method of making, reproduction, etc.....	537-538
of United States Weather Bureau, article by Henry L. Heiskell.....	537-539
publication and distribution, advantages to public.....	538-539
maps, basis, distribution, etc.....	39-40
circulation by daily papers, subscribers receiving.....	40
observations, cooperative work, extension.....	184
right of way over other messages.....	37
proverbs, some useful, article by W. J. Humphreys.....	373-382
relation of appearance of sun, etc., folklore, explanations.....	375-380
service, ocean, organization, scope, value, etc.....	37
signs.....	373-382
stations' instrumental equipment and apparatus.....	185-187
warnings, 1911-12, list.....	37
Weeks forestry law, administration.....	69, 248, 257-258
Weevil, alfalfa, investigations and control work.....	76, 81
parasite enemy, introduction, value, etc.....	147, 148
boll, control methods, study.....	79, 126, 146
cotton-boll and Mexican cotton-boll. <i>Same as Weevil, boll next above.</i>	
Weighing cotton, variations, need of uniform laws, etc.....	460
WELLS, LEVI, article on "Condensed and desiccated milk".....	335-344
Wheat, acreage and production, principal countries.....	565-568
production, farm value, prices and exports.....	569-574
crop, 1912, remarks by Secretary.....	14
durum, introduction.....	118
exports.....	23, 731
freight rates.....	705-706, 708-709, 710
growing, semiarid regions, failures, effect on settlers.....	464
hay, crop for northern Great Plains.....	467
injury by weather in 1912, note.....	546
international trade.....	577-579
losses from green bug, 1907.....	397
prices, farm and wholesale.....	20, 569, 570, 573-576
ripening, 1912, note.....	552
statistics, acreage, production, farm value, yield, prices, exports, etc.....	565-579
Whisky, exports.....	732
imports.....	721
"White blast," onion, cause, appearance, etc.....	320
blight," onion, cause, appearance, etc.....	320
White fly, Florida orange groves, control work.....	78
Williston irrigation project, note.....	123
WILSON, JAMES, report as Secretary of Agriculture.....	9-259
Wilt, tobacco, cause and control work, etc.....	136
Wind, direction, changes, etc., weather folklore, explanations.....	380

	Page.
Wine lees, imports .....	715, 741-742
Wines, imports .....	721
Wireless service, telegraphic, use and value in tropical storm warnings...	37, 178-179
Wireworms, damage to onion crop, description and remedies .....	334
Wisconsin, aid for agricultural instruction in high schools .....	475
Experiment Station, plant breeding work, results .....	213
Madison Forest Products Laboratory, research work of year .....	71
Wood ashes, imports, prices, etc. ....	525
source of potash salts .....	524-525
destructive distillation, products obtained .....	200
distillation, investigations .....	239
preservation studies, forest products laboratory, Madison, Wis. ....	71
preservative treatment, investigations, results, etc .....	237
pulp, imports .....	719, 749, 750
new sources, increased consumption, etc .....	238-239
statistics, international trade .....	665
supply failure, possibility, discussion .....	230-234
Wood-oil tree, introduction, note .....	119
Wool, cut, United States, yield of potash salts, value, etc. ....	525-526
exports .....	726
imports .....	713, 741-742
international trade .....	699
prices, Boston and other markets .....	20, 21, 696-698
production in United States .....	695
1912, remarks .....	19
statistics, production, prices, and trade .....	695-699
washings, composition, source of potash salts .....	525-526
Wool yolk, composition, source of potash salts .....	525-526
Worm. <i>See</i> Roundworm; Stomach worm.	
Wyoming, Leucite Hills, deposits of leucite, source of potash, remarks .....	528
Yuma field station work .....	123
Zante currants, varieties of grapes used, sources .....	512

